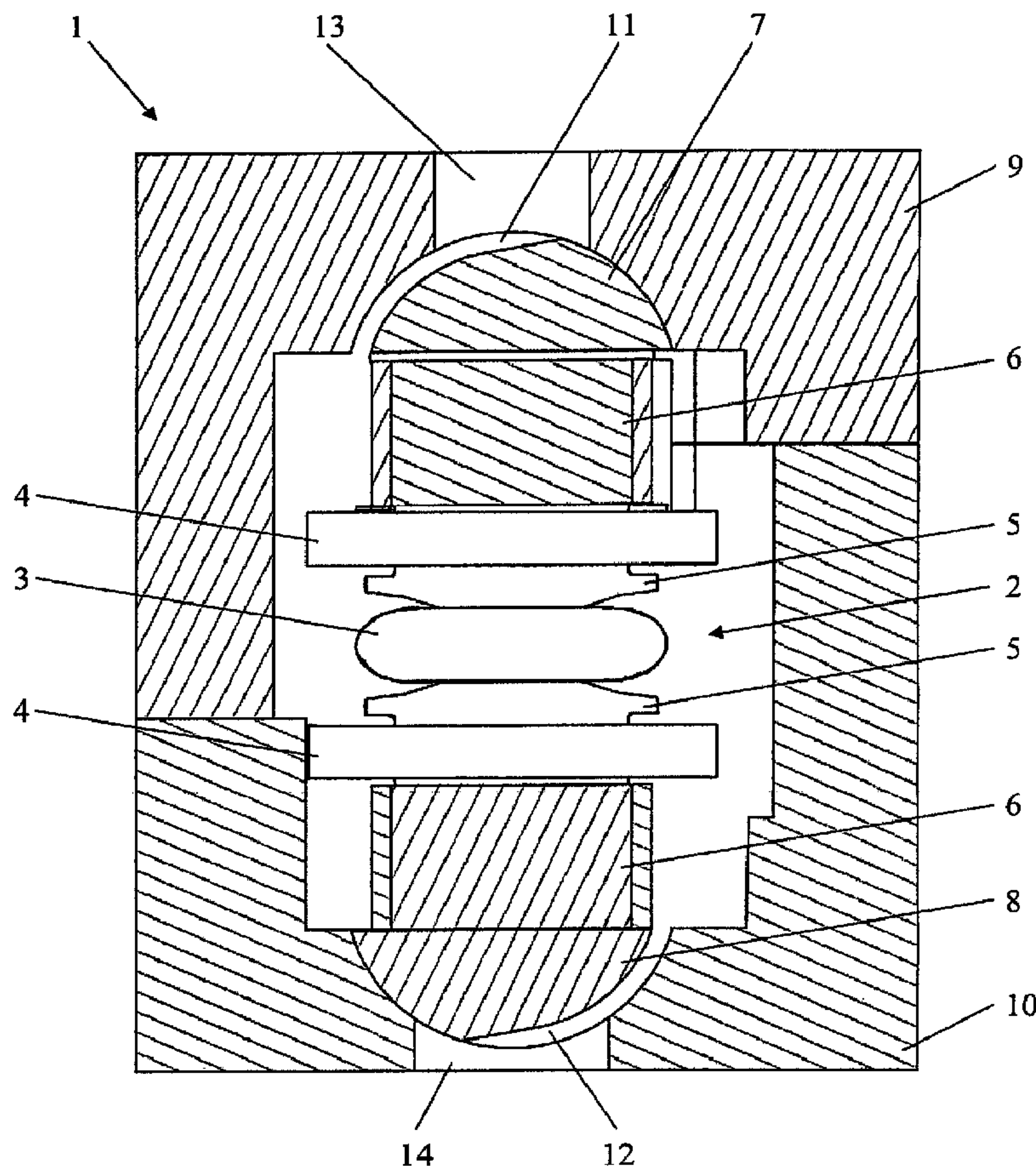




(86) **Date de dépôt PCT/PCT Filing Date:** 2007/09/06  
 (87) **Date publication PCT/PCT Publication Date:** 2008/05/08  
 (45) **Date de délivrance/Issue Date:** 2015/01/06  
 (85) **Entrée phase nationale/National Entry:** 2009/04/27  
 (86) **N° demande PCT/PCT Application No.:** EP 2007/007769  
 (87) **N° publication PCT/PCT Publication No.:** 2008/052617  
 (30) **Priorité/Priority:** 2006/10/28 (DE10 2006 050 952.8)

(51) **Cl.Int./Int.Cl. H05H 11/00** (2006.01)  
 (72) **Inventeurs/Inventors:**  
 BERMUTH, JOERG, DE;  
 GEUS, GEORG, DE;  
 HESS, GREGOR, DE;  
 VIEHBOECK, URS, DE  
 (73) **Propriétaire/Owner:**  
 SMITHS HEIMANN GMBH, DE  
 (74) **Agent:** FETHERSTONHAUGH & CO.

(54) **Titre : BLINDAGE DE PLOMB POUR UN BETATRON**  
 (54) **Title: LEAD SHIELD FOR A BETATRON**



(57) **Abrégé/Abstract:**

The invention relates to lead shielding (1) for a betatron (2) in an X-ray generator, consisting of at least four shielding parts (7, 8, 9, 10) of which two (7, 8) are semi-cylindrical and provided with recesses (11, 12) in the envelope surfaces thereof. The semi-

**(57) Abrégé(suite)/Abstract(continued):**

cylindrical shielding parts (7, 8) are arranged in corresponding recesses of the remaining shielding parts (9, 19), by means of the envelope surfaces thereof, such that the recesses (11, 12) in the envelope surfaces form air channels between the semi-cylindrical shielding parts (7, 8) and the remaining shielding parts (9, 10).

## A B S T R A C T

The invention relates to lead shielding (1) for a betatron (2) in an X-ray generator, consisting of at least four shielding parts (7, 8, 9, 10) of which two (7, 8) are semi-cylindrical and provided with recesses (11, 12) in the envelope surfaces thereof. The semi-cylindrical shielding parts (7, 8) are arranged in corresponding recesses of the remaining shielding parts (9, 10), by means of the envelope surfaces thereof, such that the recesses (11, 12) in the envelope surfaces form air channels between the semi-cylindrical shielding parts (7, 8) and the remaining shielding parts (9, 10).

## D E S C R I P T I O N

**Lead Shield For A Betatron**

The present invention relates to a lead shield comprising a cooling air duct for a betatron, in particular, for use in an X-ray testing apparatus.

As known, when inspecting large-volumed objects, such as containers and vehicles, for unlawful contents such as weapons, explosives or smuggled goods, X-ray testing apparatus is used. X-radiation is thereby produced and directed to the object. The X-radiation weakened by the object is measured by means of a detector and analyzed by an analyzer unit. In this way, the nature of the object can be deduced. An X-ray testing apparatus of this type is known, for example, from the European Patent EP 0 412 190 B1.

Betatrions are used to generate X-radiation with energy of more than 1 MeV required for the testing. These are rotary accelerators in which electrons are accelerated on an orbital path. The accelerated electrons are directed to a target where, when they strike, they produce continuous radiation whose spectrum is dependent, among other things, on the energy of the electrons.

A betatron known from the Laid-Open Specification DE 23 57 126 A1 consists of a two-part inner yoke in which the face ends of the two inner yoke parts are interspaced opposite one another. A magnetic field is generated in the inner yoke by means of two main field coils. An outer yoke connects the two ends of the inner yoke parts spaced from one another and closes the magnetic circuit.

An evacuated betatron tube, in which the electrons to be

21712-307

- 2 -

accelerated circulate, is arranged between the front ends of the two inner yoke parts. The front ends of the inner yoke parts are formed in such a way that the magnetic field generated by the main field coils forces the electrons onto an orbital path and, in addition, focuses them onto the plane in which this orbital path is situated. To control the magnetic flow, it is known to arrange a ferromagnetic insert between the front ends of the inner yoke parts within the betatron tubes.

To protect the environment against X-radiation, betatrons are provided with a lead shield which only allow the radiation to emerge at a defined point. Therefore, the object of some embodiments of the present invention is to design the lead shield in such a way that the heat generated in the betatron can be discharged.

According to some embodiments of the invention, there is provided a lead shield of a betatron in an X-ray generator, consisting of at least four shielding parts, two parts of which are semicylindrical and provided with recesses in their envelope surfaces, wherein the semicylindrical shielding parts with their envelope surfaces are disposed in corresponding recesses of the remaining shielding parts, so that the recesses in the envelope surfaces form air channels between the semicylindrical shielding parts and the remaining shielding parts.

Within the scope of this document, the term envelope surface refers to the curved surface of a semicylinder. The opposite flat surface is described as sectional plane.

21712-307

- 2a -

A lead shield of a betatron according to the invention consists of at least four shielding parts, two of which are semicylindrical and provided with recesses in their envelope surfaces, the semicylindrical shielding parts being arranged in  
5 corresponding recesses of the remaining shielding parts, so that the recesses in the envelope surfaces form air channels between the semicylindrical and the remaining shielding parts.

The advantage of this arrangement is that any complex flow channels

desired can be produced by inserting corresponding recesses into the envelope surfaces of the semicylindrical shielding parts. The curved contact surfaces between the semicylindrical and remaining shielding parts produce an effective air flow without abrupt changes in direction which would result in a stagnation of air. The X-radiation is effectively shielded by the curved envelope surface as a boundary of the air channel and the possibility of forming the air channel in curves, as there is no straight visual connection between the betatron and the environment.

In an embodiment of the invention, the two semicylindrical shielding parts are designed and arranged so as to be axially symmetrical to one another with respect to their cross section. This means that the air flowing into the shield along an envelope surface must reach the diagonally opposite edge of the second semicylinder in order to flow out again. This leads to the air flowing through the entire interior of the lead shield.

Preferably, at least two of the remaining shielding parts have air channels which connect the recesses in the envelope surfaces of the semicylindrical shielding parts with the environment. The air flows through said air channels from the environment into the interior of the shield or out of it again.

In an embodiment of the invention, the semicylindrical shielding parts lie with their sectional planes on opposing front ends of the outer yoke of the betatron. This ensures that the air is conveyed past the main field coils, the betatron tube and inner yoke and does not flow through between the semicylindrical shielding parts and outer yoke. The sectional planes of the semicylindrical shielding parts are preferably at least as large as the front ends of the outer yoke. The result of this is that the incoming air is not hindered by the front end of the outer yoke and that dynamic

pressure forms which deteriorates the cooling power.

The lead shield according to the invention is advantageously used with a betatron in an X-ray testing apparatus for security inspection of objects. Electrons are injected into the betatron and accelerated before they are directed to a target, consisting e.g. of tantalum. There, the electrons generate X-radiation having a known spectrum. The X-radiation is directed to the object, preferably a container and/or a vehicle, and there modified, for example, by dispersion or transmission damping. The modified X-radiation is measured by an X-ray detector and analyzed by means of an analyzer unit. The nature or the contents of the object are deduced from the result.

The present invention will be described in greater detail with reference to an embodiment in the drawings, showing:

- Fig. 1 a schematic sectional representation through a lead shield according to the invention,
- Fig. 2 the representation of Fig. 1 with indicated air flow, and
- Fig. 3 a spatial view of a semicylindrical shielding part.

Fig. 1 shows a schematic sectional representation of a lead shield 1 according to the invention with a betatron 2 disposed therein. The betatron consists of a betatron tube 3, main field coils 4, an inner yoke 5 and an outer yoke 6, however, it may comprise another structure.

The lead shield 1 consists of two semicylindrical shielding parts 7 and 8, as well as two remaining shielding parts 9 and 10. Recesses 11 or 12 are made in the envelope surfaces of the

semicylindrical shielding parts 7 and 8. The semicylindrical shielding part 7 is situated in a recess of the shielding part 9 in such a way that the recess 11 forms an air channel between the shielding parts 7 and 9 in its envelope surface. Similarly, the recess 12 in the envelope surface of the semicylindrical shielding part 8 forms an air channel between the shielding parts 8 and 10. Air channels in the form of recesses 13 and 14 in the shielding parts 9 and 10 connect the recesses 11 or 12 with the environment of the lead shield 1.

The lead shield 1 is designed such that the sectional planes of the semicylindrical shielding parts 7 and 8 rest on the opposing rectangular front ends of the outer yoke 6. In the sectional representation in Fig. 1, the recesses 11 and 12 in the envelope surfaces of the semicylindrical shielding parts 7 or 8 are designed and arranged axially symmetrical to one another. This results in the flow of air through the lead shield 1 indicated by arrows in Fig. 2. The air reaches into the left upper corner of the inside of the lead shield 1 through the recesses 13 and 11. Since the air outlet in the form of recesses 12 and 14 are situated on the right lower corner, the air flows diagonally through the interior of the lead shield 1 past the betatron tube 3, the main field coils 4 and the inner yoke 5 and in this way draws off the heat produced in the betatron 2. Optionally, the air is blown into the recess 13 and/or drawn off from the recess 14 e.g. by ventilators or exhausts.

Fig. 3 shows a spatial view of the semicylindrical shielding part 7. The width  $b$  of recess 1 corresponds to the expansion of the front end of the outer yoke 6 along an axis which is vertical on the drawing plane of Figs. 1 and 2. Optionally, the recess 11 extends over the entire height of the semicylindrical shielding part 7. Preferably, the expansion of recess 13 along the vertical axis on the drawing plane of Figs. 1 or 2 corresponds to the width

of recess 11 in the envelope surface of the semicylindrical shielding part 7 in Fig. 3. The preceding description applies analogously to the semicylindrical shielding part 8 and recesses 12 and 14.

21712-307

- 7 -

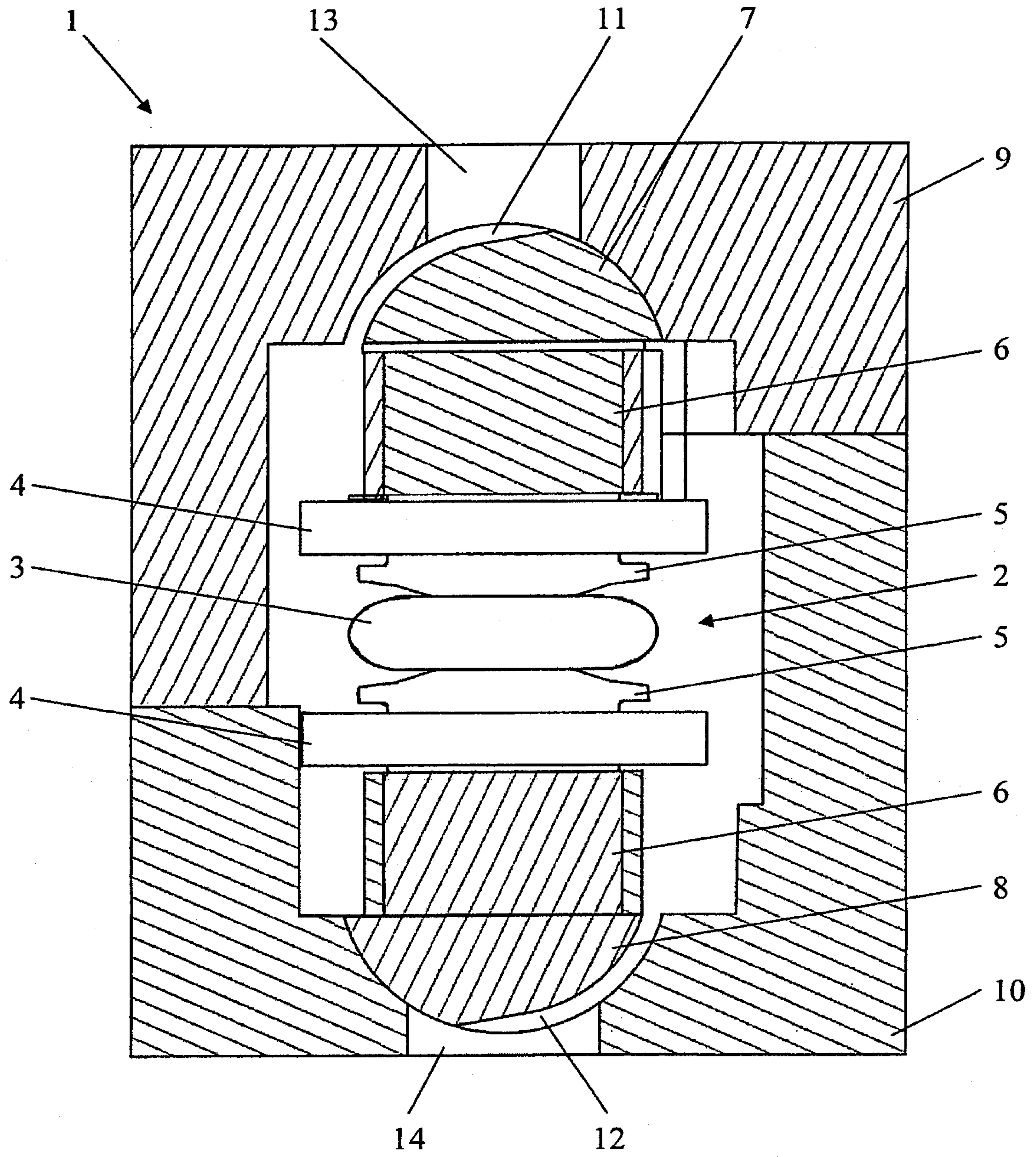
CLAIMS:

1. A lead shield of a betatron in an X-ray generator, consisting of at least four shielding parts, two parts of which are semicylindrical and provided with recesses in their envelope surfaces, wherein the semicylindrical shielding parts with their envelope surfaces are disposed in corresponding recesses of the remaining shielding parts, so that the recesses in the envelope surfaces form air channels between the semicylindrical shielding parts and the remaining shielding parts.
2. The lead shield according to claim 1, wherein the semicylindrical shielding parts are designed and arranged axially symmetrical to one another with respect to their cross section.
3. The lead shield according to one of the claims 1 or 2, further comprising air channels in at least two of the remaining shielding parts which connect the recesses in the envelope surfaces of the semicylindrical shielding parts with the environment.
4. The lead shield according to one of the claims 1 to 3, wherein the semicylindrical shielding parts lie with their sectional planes on the opposing front ends of an outer yoke of the betatron.
5. The lead shield according to claim 4, wherein the contact surfaces of the semicylindrical shielding parts are at least as large as the front ends of the outer yoke.

21712-307

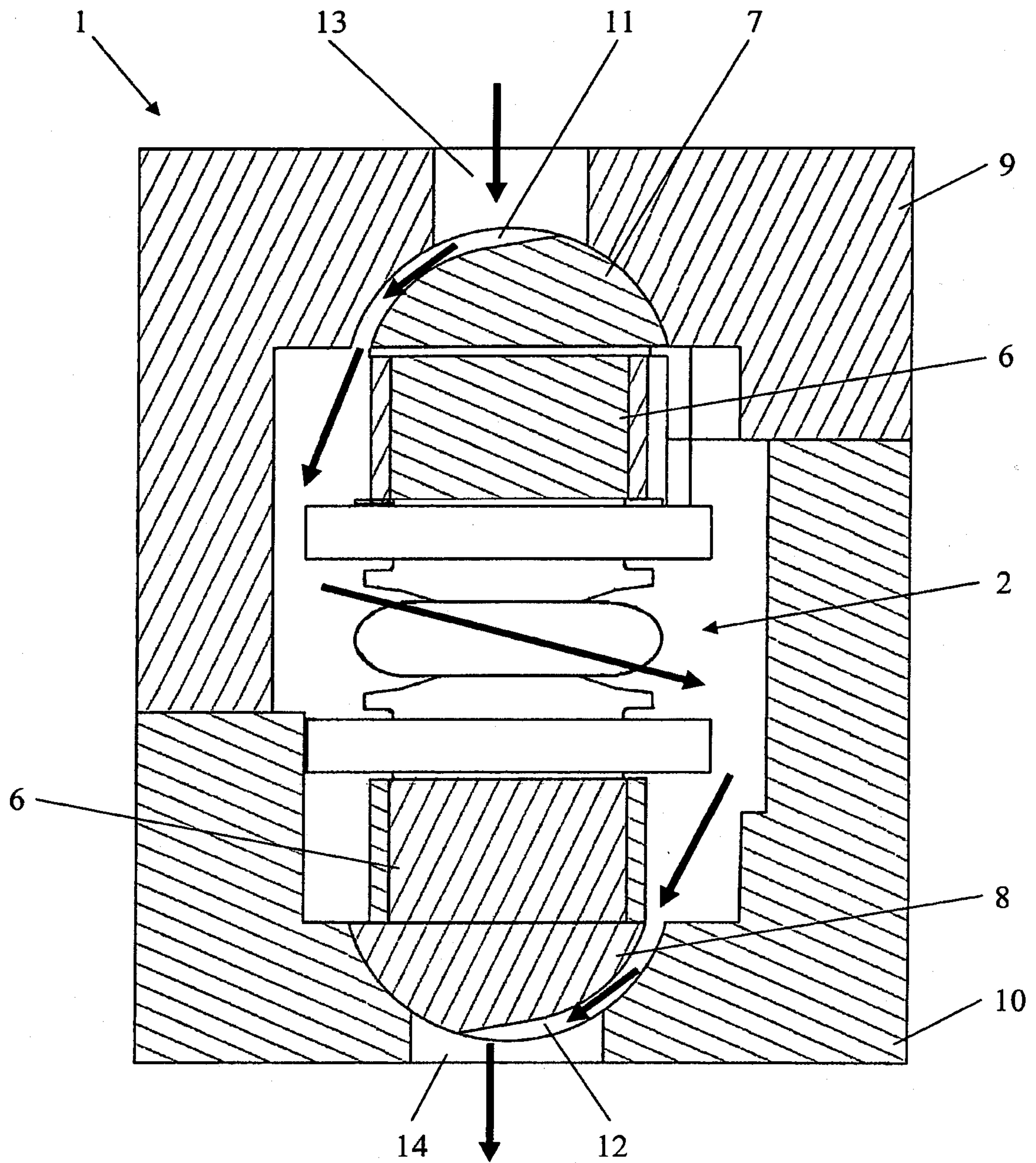
- 8 -

6. An X-ray testing apparatus for security inspection of objects, comprising a betatron with a lead shield according to one of the claims 1 to 5 and a target for generating X-radiation, as well as an X-ray detector and an analyzer unit.

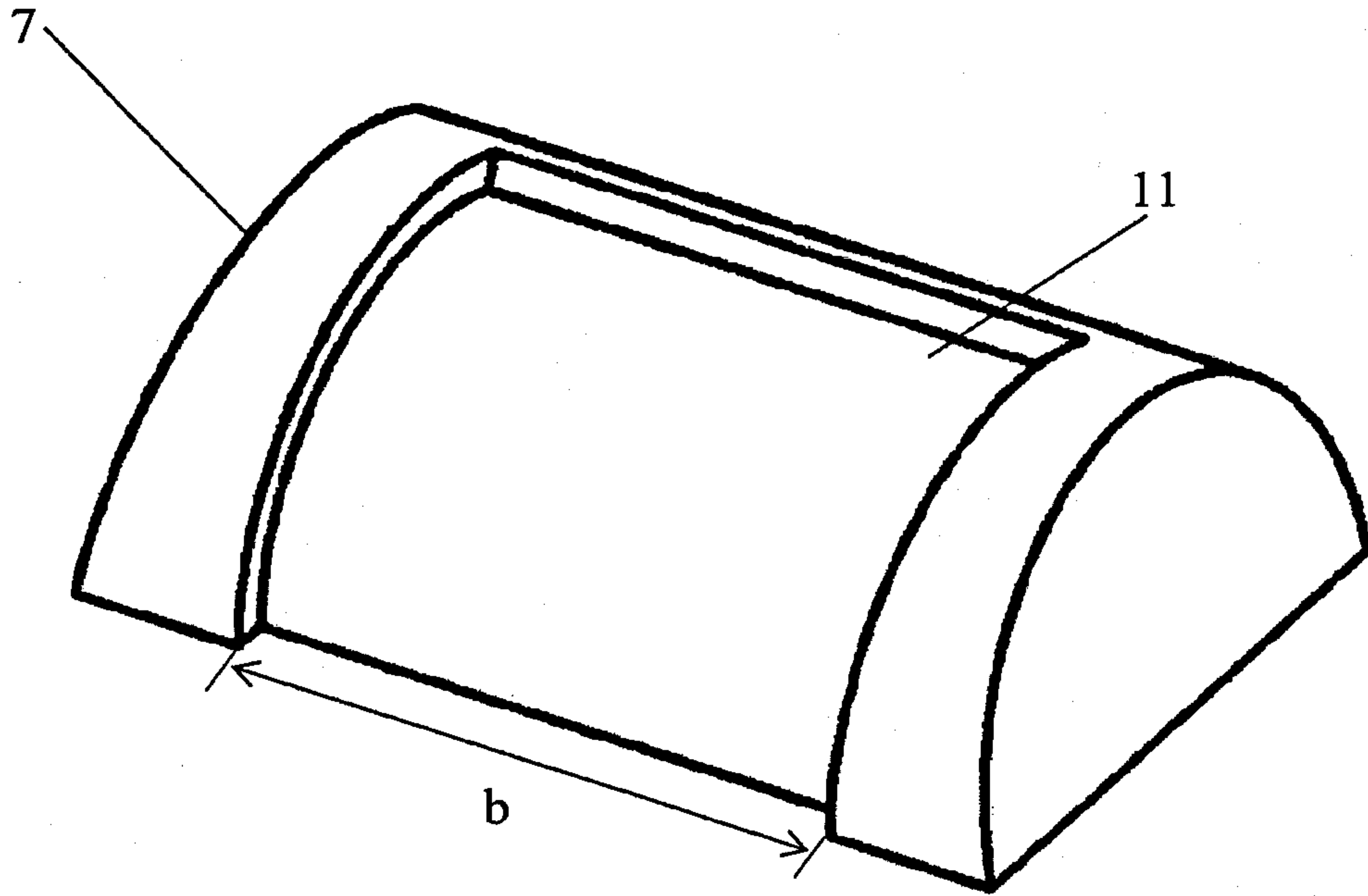


**Fig. 1**

2/3



**Fig. 2**



**Fig. 3**

