

(No Model.)

3 Sheets—Sheet 1.

M. E. KNIGHT & C. S. GOODING. NUMBERING MECHANISM.

No. 527,205.

Patented Oct. 9, 1894.

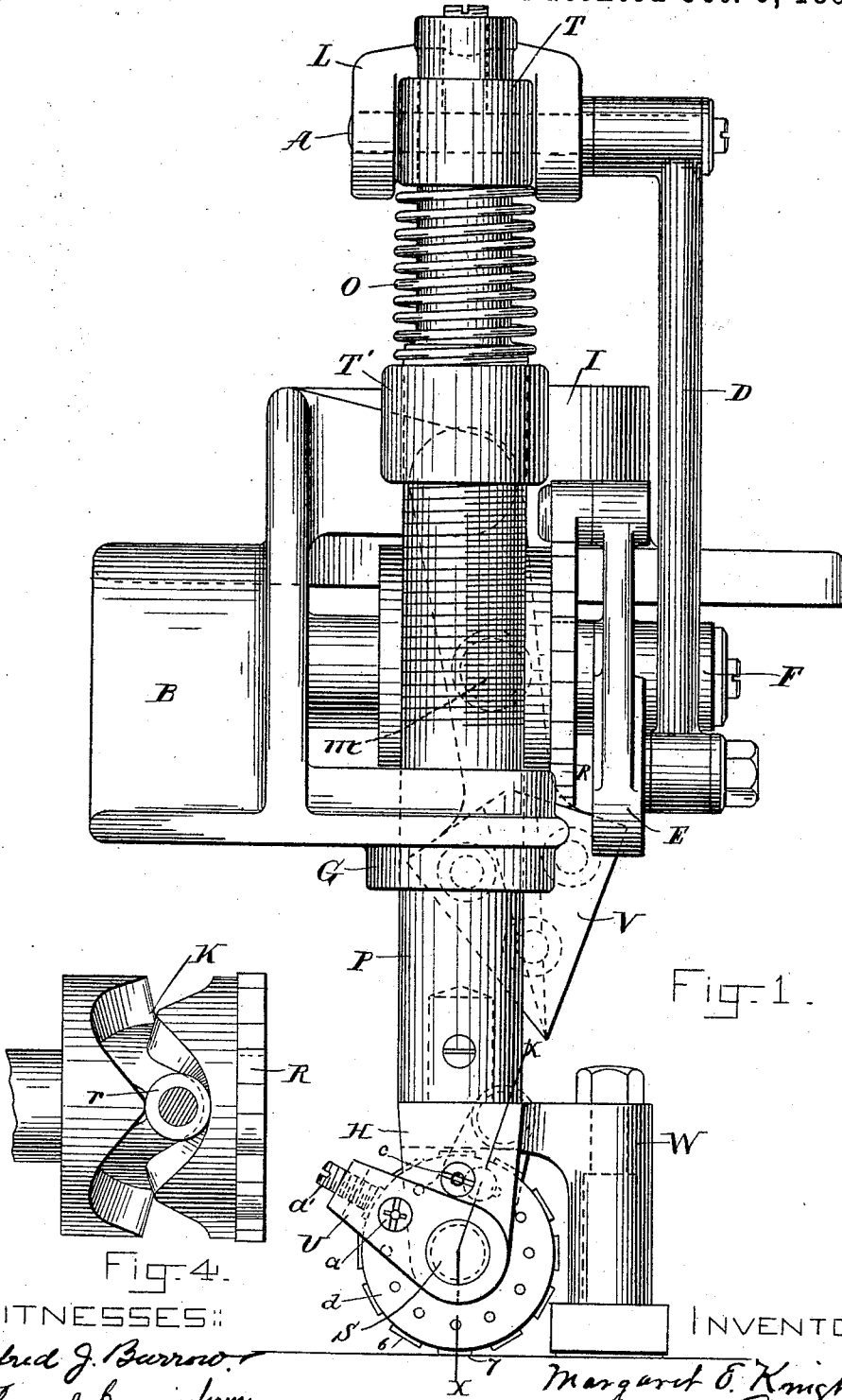

Fig. 1.

Fig. 4.

WITNESSES:
Alfred J. Barron.
Thomas J. Cunningham.

INVENTORS:
Margaret E. Knight
Chas. S. Gooding.

(No Model.)

3 Sheets—Sheet 2.

M. E. KNIGHT & C. S. GOODING.
NUMBERING MECHANISM.

No. 527,205.

Patented Oct. 9, 1894.

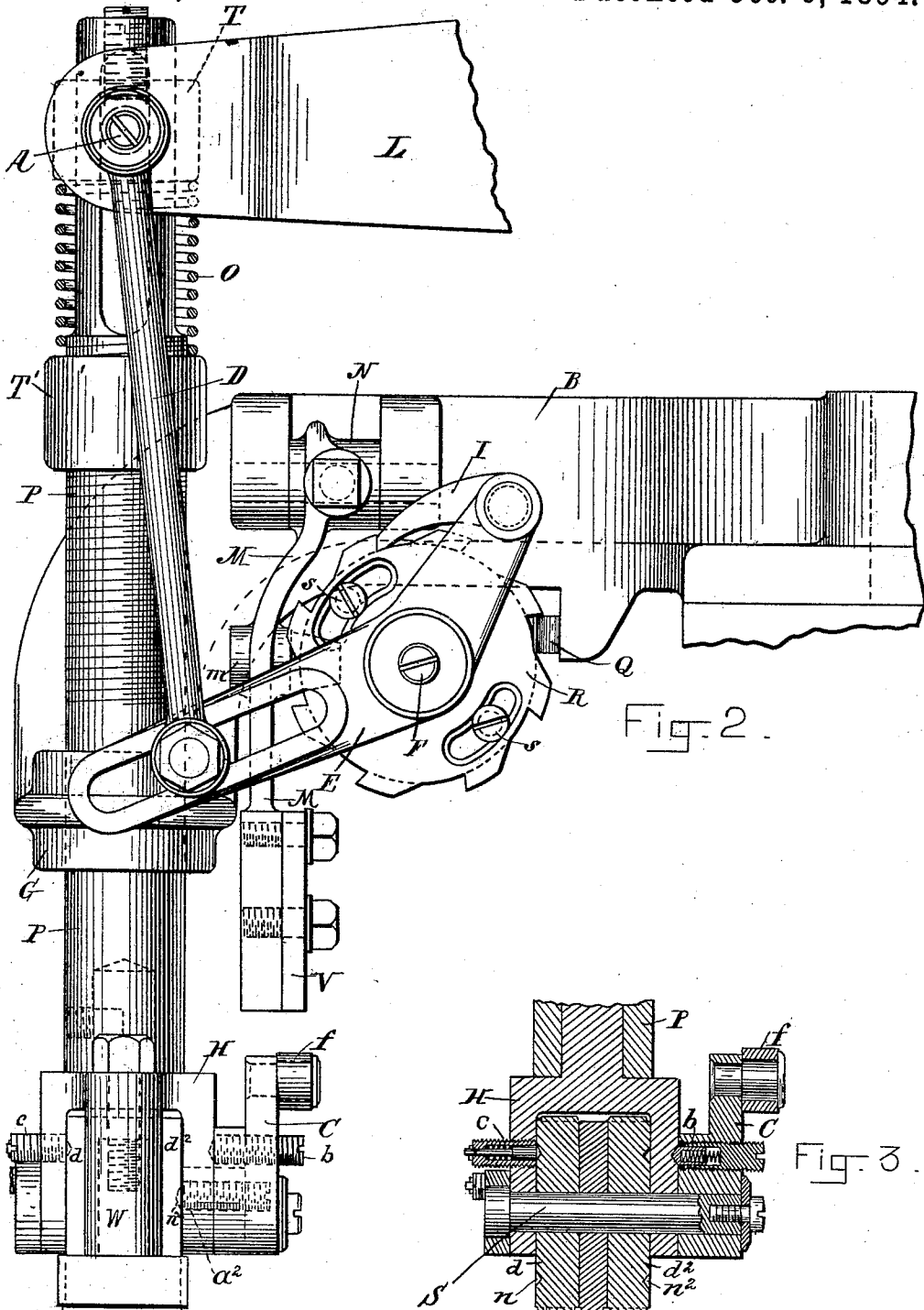

Fig. 2.

Fig. 3.

WITNESSES:
Alfred J. Burrow,
Thomas J. Birmingham.

INVENTORS:
Marquett E. Knight
Chas. S. Gooding

(No Model.)

3 Sheets—Sheet 3.

M. E. KNIGHT & C. S. GOODING.
NUMBERING MECHANISM.

No. 527,205.

Patented Oct. 9, 1894.

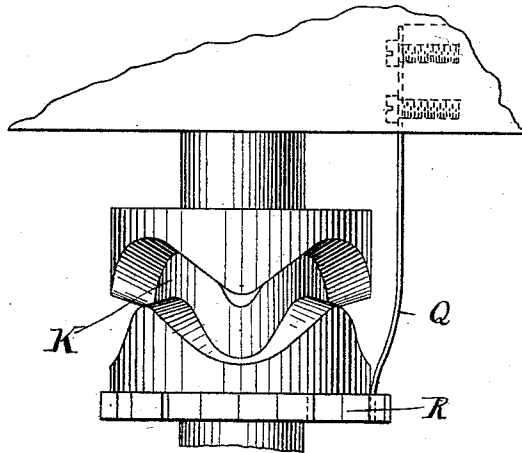

Fig. 5.

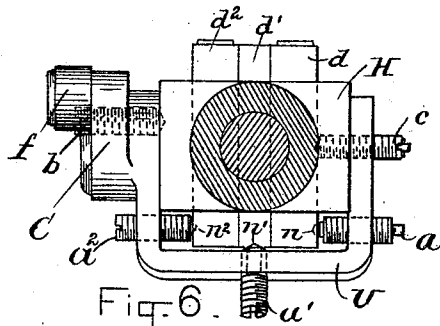

Fig. 6.

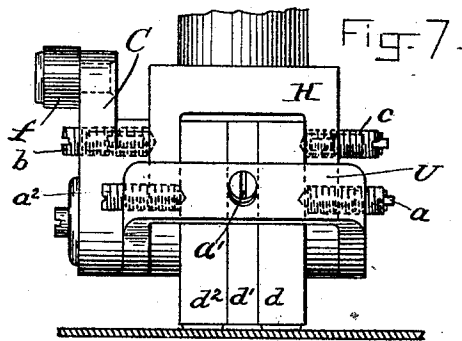

Fig. 7.

WITNESSES:
Alfred J. Burrows
Thomas J. Birmingham

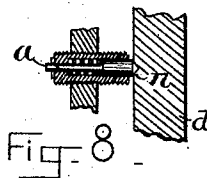

Fig. 8.

INVENTORS:
Margaret S. Knight
Chas. S. Gooding

UNITED STATES PATENT OFFICE.

MARGARET E. KNIGHT, OF SOUTH FRAMINGHAM, AND CHARLES S. GOODING, OF BROOKLINE, ASSIGNORS TO SAID KNIGHT, AND ROBERT D. EVANS AND JOHN S. LOCKWOOD, OF BOSTON, MASSACHUSETTS.

NUMBERING MECHANISM.

SPECIFICATION forming part of Letters Patent No. 527,205, dated October 9, 1894.

Application filed May 29, 1894. Serial No. 512,820. (No model.)

To all whom it may concern:

Be it known that we, MARGARET E. KNIGHT, of South Framingham, in the county of Middlesex, and CHARLES S. GOODING, of Brookline, in the county of Norfolk, both in the State of Massachusetts, have invented certain Improvements in Numbering Mechanism, of which the following is a specification.

This invention relates to improvements in numbering mechanism to be attached to machines employed in making articles upon which it is desired to imprint or stamp numbers or designating characters to indicate size, style or kind, for instance, such articles as boots and shoes, to which it is especially applicable; and the invention consists chiefly in constructing the numbering devices so that they may be automatically changed alternately from one to another of two successive numbers or designating characters, as is hereinafter described with reference to the accompanying drawings, in which—

Figure 1 is a front elevation of the numbering mechanism illustrated as attached to a machine for cutting shoe-soles, for example. Fig. 2 is a side elevation of the same mechanism. Fig. 3 is a section on line $x-x$ Fig. 1, through the numbering disks and the lever which reciprocates them. Fig. 4 is an elevation of the cam and ratchet by which the disk-reciprocating lever is operated. Fig. 5 is a plan view of the same parts showing the retaining spring for the ratchet. Fig. 6, is a plan view of the numbering disks and their holder and connected parts. Fig. 7 is a front elevation of the parts shown in Fig. 6. Fig. 8, is a section of a screw spring-detent such as used for holding the numbering disks against accidental turning.

Referring to the drawings, B is the bracket upon which the numbering mechanism is supported; L, the lever by which the plunger P is raised. This plunger is supported by a pin A which passes through a slot therein and through the forked ends of lever L, and is guided by a ring G upon the bracket B. At the lower end of the plunger P, a hanger H is secured in which the numbering and lettering disks d, d', d^2 , are supported on a spindle S, and upon the same spindle is hung a

yoke U, which forms a part of a bell-crank lever C. The numbering disks d, d', d^2 , are respectively held against accidental movement by screw regulated spring-detents, a, a', a^2 , which pass through the yoke U, and have their points engage with notches n, n', n^2 , formed in the said disks. The lever C, is held against accidental movement by a spring-detent b , the point of which engages with notches in the side of the hanger H, and upon the upper end of one arm of the crank-lever is a friction roll f , to facilitate operation of the crank-lever in the manner hereinafter described.

It will be understood that when the points of the several detents a, a', a^2 , are in engagement with a notch in their respective disks, they all will be turned back and forth upon the spindle S whenever the lever C is so turned. If however it is desired to have the same letter or figure printed by the disk d at every stroke of the plunger, the detent a , can be withdrawn and the detent c , which works through the side of the hanger H turned in so that its point engages with a notch in the disk d . Thus it will remain in a fixed position and will not be affected by the movement of the yoke U.

For the purpose of stamping designating marks upon shoe-soles the disk d , may contain dies or type of letters upon its periphery. The disk d' , the sign of the fraction $\frac{1}{2}$, and the disk d^2 , may contain dies or type of figures, and as the $\frac{1}{2}$ will be the only designation upon the disk d' , under such circumstances that can be readily thrown out of use by turning the disk one notch.

Instead of disks pivoted blocks containing the requisite number of dies for letters and figures may be used, but when a large number of dies for figures, from 1 to 13 for instance, are desired the disks will be found most desirable.

Before starting the machine the disks d, d', d^2 , can be turned by hand into any position so as to place the desired figures and letters at the bottom.

In filling orders for a specified number of cases of assorted sizes of shoes it is desirable to make up a portion of each size to be de-

livered as required, and when cutting soles for this purpose upon a machine like that described in Letters Patent Nos. 444,982 and 494,784, it becomes convenient to cut two different sizes alternately, and in order to number these properly it is necessary to reciprocate the numbering disks, so as to stamp first one number and then the other. This is accomplished by the use of the following devices: The upper end of a pitman D, is hung upon the pin A. The lower end of the pitman is connected to one end of a lever E which is pivoted at F in the shaft of a cam K to which the ratchet R is attached by screws s, s. To the other end of the lever E is pivoted a pawl I, which rests upon the ratchet R. The cam K is immediately back of the said ratchet and in the groove thereof runs a roll r supported upon a stud m projecting from a swinging lever M. This lever M is pivoted at N in bearings attached to the bracket B, and secured to the lower end of this lever is a V-shaped cam-plate which hangs directly over the friction roll f upon the upper end of the crank-lever C. Said V cam-plate is shown in front view in Fig. 1 and side view in Fig. 2. The pitman D is connected with the lever E by a pin extending through a slot therein so that by adjusting the point of connection of the pitman with the lever E toward or from its fulcrum F, the length of the stroke of the ratchet R may be regulated. In order to give a yielding stroke of the numbering disks upon the material beneath, a spring O, is placed between the two collars T, T', the upper one T, being loose upon the plunger P, and held by the pin A; the lower one T' being secured to the plunger by a screw thread thereon and over which it may be turned for the purpose of regulating the tension of the spring O. A slot in the upper end of the plunger permits the pin A, to move down and up as the said spring is compressed or allowed to expand. The ratchet R is prevented from turning backward by a flat spring Q, one end of which is fastened to the bracket B and the other bears upon the face of the ratchet wheel; and further, for the purpose of imprinting any additional ornamental or distinguishing design upon the material, a bracket W is attached to the hanger H, and by securing to the bottom of said bracket W, a stamp having the desired ornamental design upon it, each time that the plunger P descends the design will be impressed upon the material beneath.

The operation of the mechanism is as follows: When the lever I descends carrying with it the plunger P, and thus pressing the numbering disks upon the material, the pitman A depresses the outer end of the lever E thereby causing the pawl I to turn the ratchet R and with it the cam K to which it is attached. The parts should be so adjusted that each stroke of the lever E will turn the said cam a sufficient distance to move the roll r , which runs in its groove, from one ex-

treame to the other of one of the curves of its sinuous path, or in other words from a crest to trough or vice versa of the wave line of said path, and as said cam-roll r is secured to the swinging lever M, the V cam-plate at its lower end will thus be moved from its extreme right hand position as shown in Fig. 1, to its extreme opposite or left hand position. When the plunger P is raised the slotted end of the lever E will be raised and the pawl I will run back over one tooth of the ratchet and at the next downward stroke of the plunger the cam K will be given another partial turn and by its action upon the lever M, move the cam-plate V back to its right hand position again. When the V plate is in the position shown in Fig. 1, and the plunger is raised the friction roll f will strike upon the left side of said cam-plate, and the crank-lever C will be turned to the left and with it such numbering disks as are secured to the yoke U, thus placing, for instance, the letter W on disk d , the fraction $\frac{1}{2}$ on disk d' and the figure 6, on disk d^2 , at the bottom, ready to be imprinted upon the material when the plunger next descends, and by that operation the cam-plate V, will be moved to its extreme left hand position, so that when the plunger next ascends the roll f will strike upon the right hand side of said cam-plate and turn the lever C and said disks, to the right, thus placing, for example, the letter N on disk d , a blank on disk d' , and the figure 7 on disk d^2 , at the bottom, or in the position shown in Fig. 1. It will be understood therefore that at each downward movement of the plunger P, the cam-plate V will be moved from one side to the other, and at each upward movement of the plunger the lever C and as many disks as are secured to the yoke U, will be turned, first one way and then the other, thus causing any two successive figures and letters to be alternately impressed upon the material; or as heretofore described the disk d , may be disengaged from the yoke U and engaged with the hanger H and then only the other two disks will be changed at each upward movement of the plunger P.

We claim—

1. In a numbering machine, the combination of numbering dies, reciprocating mechanism which carry said dies, a tilting lever adapted to engage one or more of said dies, a cam-plate to act upon said lever and mechanism to change its position at each stroke of the reciprocating mechanism whereby said tilting lever will be changed automatically from one position to another by the movement of said reciprocating mechanism, for the purpose described.

2. In a numbering machine, the combination of a reciprocating plunger carrying movable numbering disks at one end, a pivoted lever provided with devices to engage one or more of said disks, a swinging cam-plate to act upon said pivoted lever when the plunger is raised, a cam to vibrate said cam-plate and

mechanism connecting said cam with the plunger, whereby said cam-plate will be swung from one extreme of its path of vibration to the other at each stroke of said plunger for the purpose described.

3. In a numbering machine, the combination of a plunger carrying numbering dies, and devices to engage and move one or more of said dies, mechanism to reciprocate said plunger, a cam surface to act upon said die moving devices when the plunger is raised, a cam to vibrate said cam-surface, a ratchet and pawl to operate said cam, and mechanism which connects said pawl with the plunger actuating mechanism, whereby each stroke of the plunger will swing said cam-surface from one side to the other of said die moving devices for the purpose described.

4. In a numbering machine the combina-

tion of a reciprocating plunger; adjustable numbering dies and a crank-lever adapted to engage and reciprocate one or more of said dies, supported by said plunger; a vibrating lever supporting a wedge-shape plate in the path of movement of one arm of said crank-lever and mechanism connecting said vibrating-lever and the plunger operating mechanism, which is adapted, at each stroke of the plunger to move said wedge-plate from one side to the other of the middle of the arc of vibration of the said arm of the crank-lever, for the purpose described.

MARGARET E. KNIGHT.
CHAS. S. GOODING.

Witnesses:

ALFRED J. BURROWS,
THOMAS J. CUNNINGHAM.