



(51) International Patent Classification:

*F16H 55/08* (2006.01)    *F16H 1/08* (2006.01)  
*B23F 7/00* (2006.01)    *F16H 55/02* (2006.01)  
*B23H 9/00* (2006.01)    *F16H 55/06* (2006.01)  
*B23P 15/14* (2006.01)

(21) International Application Number:

PCT/US2017/015586

(22) International Filing Date:

30 January 2017 (30.01.2017)

(25) Filing Language:

English

(26) Publication Language:

English

(30) Priority Data:

62/290,658    3 February 2016 (03.02.2016)    US

(71) Applicant: SIKORSKY AIRCRAFT CORPORATION

[US/US]; 6900 Main Street, Stratford, Connecticut 06615 (US).

(72) Inventors: BITTNER, Edward H.; 87 Mungertown Road, Madison, Connecticut 06443 (US). HANSEN, Bruce D.; 44 Hemlock Drive, Shelton, Connecticut 06484 (US). MUSSEL, Christopher John; 4 Tetlak Lane, Oxford, Connecticut 06478 (US).

(74) Agent: HAYTER, Alicia; CANTOR COLBURN LLP, 20 Church Street, 22nd Floor, Hartford, Connecticut 06103 (US).

(81) Designated States (unless otherwise indicated, for every kind of national protection available): AE, AG, AL, AM,

AO, AT, AU, AZ, BA, BB, BG, BH, BN, BR, BW, BY, BZ, CA, CH, CL, CN, CO, CR, CU, CZ, DE, DJ, DK, DM, DO, DZ, EC, EE, EG, ES, FI, GB, GD, GE, GH, GM, GT, HN, HR, HU, ID, IL, IN, IR, IS, JP, KE, KG, KH, KN, KP, KR, KW, KZ, LA, LC, LK, LR, LS, LU, LY, MA, MD, ME, MG, MK, MN, MW, MX, MY, MZ, NA, NG, NI, NO, NZ, OM, PA, PE, PG, PH, PL, PT, QA, RO, RS, RU, RW, SA, SC, SD, SE, SG, SK, SL, SM, ST, SV, SY, TH, TJ, TM, TN, TR, TT, TZ, UA, UG, US, UZ, VC, VN, ZA, ZM, ZW.

(84) Designated States (unless otherwise indicated, for every kind of regional protection available): ARIPO (BW, GH, GM, KE, LR, LS, MW, MZ, NA, RW, SD, SL, ST, SZ, TZ, UG, ZM, ZW), Eurasian (AM, AZ, BY, KG, KZ, RU, TJ, TM), European (AL, AT, BE, BG, CH, CY, CZ, DE, DK, EE, ES, FI, FR, GB, GR, HR, HU, IE, IS, IT, LT, LU, LV, MC, MK, MT, NL, NO, PL, PT, RO, RS, SE, SI, SK, SM, TR), OAPI (BF, BJ, CF, CG, CI, CM, GA, GN, GQ, GW, KM, ML, MR, NE, SN, TD, TG).

Declarations under Rule 4.17:

- as to applicant's entitlement to apply for and be granted a patent (Rule 4.17(ii))
- as to the applicant's entitlement to claim the priority of the earlier application (Rule 4.17(iii))
- of inventorship (Rule 4.17(iv))

Published:

- with international search report (Art. 21(3))

(54) Title: ADVANCED HERRINGBONE GEAR DESIGN

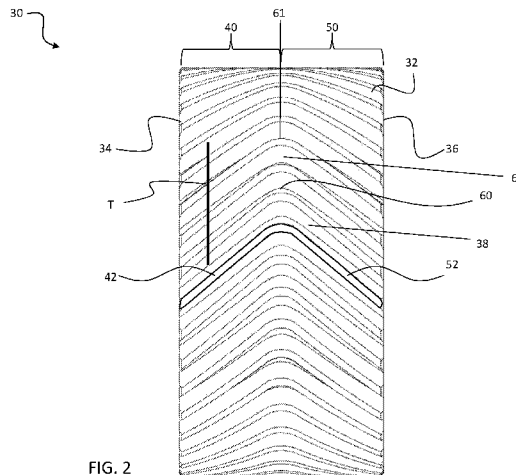
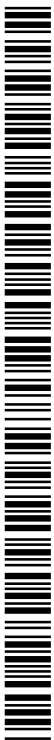

FIG. 2

(57) Abstract: A herringbone gear includes a cylindrical body having a circumferential face having a width. A first helical gear tooth on the circumferential face has a first configuration, a second helical gear tooth on the circumferential face has a second configuration, and a transition on the circumferential face extends between the first helical gear tooth and the second helical gear tooth. An involute form taken within a transverse plane of the circumferential face remains constant over the width.



## ADVANCED HERRINGBONE GEAR DESIGN

## BACKGROUND OF THE INVENTION

[0001] The subject matter disclosed herein generally relates to gear teeth, and more particularly, to improvements in herringbone gear teeth and methods for their manufacture.

[0002] Gears are used in various industrial and technological applications to permit power transmission from one rotating or translating element to another. Each gear generally includes an array of gear teeth that mesh with the gear teeth of another gear so that the rotation or translation of the first gear can be transmitted to the second. The shapes of the gear teeth can be varied with some gear teeth being linearly shaped, some being helically shaped and others being provided as double-helical or herringbone shaped.

[0003] Spur gears have gear teeth that are arranged parallel to the axis of rotation. Helical gears have an array of teeth following helical paths, arranged around the axis of rotation. Helical gears are preferred for use in high speed and high torque gearboxes since they transmit power between each other in a quieter and more efficient manner. Efficiency and strength can be further improved by providing the gear teeth with a very smooth finish by finish-grinding the teeth for example.

[0004] Gears having gear teeth that are double-helically (or herringbone) shaped include a side-to-side (not face to face) combination of two helical gears of opposite hands and, from a top-wise viewpoint, the helical grooves form a V formation with an apex in the middle. Whereas single helical gears tend to produce axial loading, for double-helical or herringbone gears, a side-thrust of one half of each gear is balanced by that of the other half. This means that gears having double-helical or herringbone shaped gear teeth can be used in gearboxes without requiring substantial thrust bearings.

## BRIEF DESCRIPTION OF THE INVENTION

[0005] According to one embodiment, a herringbone gear includes a cylindrical body having a circumferential face having a width. A first helical gear tooth on the circumferential face has a first configuration, a second helical gear tooth on the circumferential face has a second configuration, and a transition on the circumferential face extends between the first helical gear tooth and the second helical gear tooth. An involute form taken within a transverse plane of the circumferential face remains constant over the width.

[0006] In addition to one or more of the features described above, or as an alternative, in further embodiments wherein the first configuration and the second configuration are opposites.

[0007] In addition to one or more of the features described above, or as an alternative, in further embodiments the transition includes a radius.

[0008] In addition to one or more of the features described above, or as an alternative, in further embodiments conjugate motion occurs over an entire surface of the first helical gear tooth, the transition gear tooth and the second helical gear tooth when meshed with a corresponding herringbone gear.

[0009] In addition to one or more of the features described above, or as an alternative, in further embodiments the herringbone gear is installed within a power transmission assembly.

[0010] In addition to one or more of the features described above, or as an alternative, in further embodiments the power transmission assembly is part of a rotary wing aircraft.

[0011] According to one embodiment of the invention, a method of forming a double-helical gear includes forming a portion of an aligned first gear tooth, transition, and second gear tooth via a single pass of a spindle such that an involute form taken within a transverse plane remains constant over a width of the gear.

[0012] In addition to one or more of the features described above, or as an alternative, in further embodiments

[0013] In addition to one or more of the features described above, or as an alternative, in further embodiments a longitudinal axis of the spindle is arranged generally perpendicular to an axis of rotation of the gear, the longitudinal axis extending through the gear.

[0014] In addition to one or more of the features described above, or as an alternative, in further embodiments forming the transition includes varying an orientation of the longitudinal axis of the spindle relative to the gear to maintain a constant involute form in the transition.

[0015] In addition to one or more of the features described above, or as an alternative, in further embodiments a portion of the first gear tooth is formed by moving the spindle generally linearly.

[0016] In addition to one or more of the features described above, or as an alternative, in further embodiments a portion of the second gear tooth is formed by moving the spindle generally linearly.

[0017] In addition to one or more of the features described above, or as an alternative, in further embodiments the spindle includes a grinding wheel configured to rotate about the longitudinal axis of the spindle.

[0018] In addition to one or more of the features described above, or as an alternative, in further embodiments the spindle is configured to removed material from the gear via electrochemical grinding.

#### BRIEF DESCRIPTION OF THE DRAWINGS

[0019] The subject matter, which is regarded as the invention, is particularly pointed out and distinctly claimed in the claims at the conclusion of the specification. The foregoing and other features, and advantages of the invention are apparent from the following detailed description taken in conjunction with the accompanying drawings in which:

[0020] FIG. 1A is a front view of an example of a double-helical gear having an apex gap;

[0021] FIG. 1B is a front view of an example of a herringbone gear;

[0022] FIG. 2 is a front view of a herringbone gear according to an embodiment;

[0023] FIG. 3 is a perspective view of a grinding spindle configured to form one or more gear teeth according to an embodiment;

[0024] FIG. 3A is a side view of the grinding spindle as it forms a gear tooth according to an embodiment;

[0025] FIG. 4 is a cross-section of FIG. 3 taken in a transverse plane through the gear and spindle according to an embodiment; and

[0026] FIGS. 5A and 5B are perspective views of a transverse plane and a normal plane of a gear tooth during formation of a gear according to an embodiment.

[0027] The detailed description explains embodiments of the invention, together with advantages and features, by way of example with reference to the drawings.

## DETAILED DESCRIPTION OF THE INVENTION

[0028] In aerospace transmission design, transmission weight reduction is of considerable importance. Thus, since the gears inside a transmission are normally the heaviest components in a drive system, reducing gear size and number of gears can be useful in reducing transmission weight and volume. As will be described below, gear size reductions can be achieved by eliminating extraneous gear features, and improving the efficiency of the gears that are included.

[0029] Helical gears, and in particular, double helical or herringbone gears are preferred for use in high speed and high torque gearboxes. However, manufacturing limitations typically affect how these gears are formed. For instance, a herringbone gear, as shown in FIG. 1B, cannot be finished by grinding due to manufacturing limitations. A double-helical gear that may be finish-ground is illustrated in FIG. 1A and includes an apex gap 16. Specifically, in order to finish-grind the gear teeth, current manufacturing techniques employ a grinding wheel which necessitates the presence of this gap at the apex of the V formation as shown. This gap is required since, when forming one tooth of the V formation, the grinding wheel would otherwise collide with the other tooth of the V formation. The double-helical gear 10 of FIG. 1A includes a first side 12 having a helical gear pattern of a first hand, a second side 14 having a helical gear pattern of a second hand, opposite the first hand. The first side 12 and second side 14 of the gear 10 abut one another at an apex 16 defined axially there between. The double-helical gear 10 has a relatively high gear contact ratio owing to the presence of the helical gear patterns of the first and second sides 12 and 14. As a result, a gear mesh of the double-helical gear 10 exhibits increased strength and reduced noise signature as compared to that of a straight spur gear. As a result of the processes and machines used to shape and precision grind the gear teeth, the available geometries of the gear are restricted. The additional material needed to provide the apex gap 16 adds considerable weight and size penalty to an overall transmission system in which the double-helical gear 10 resides, without providing any useful function.

[0030] Typically, when formed via various machining methods, herringbone gears, such as shown in FIG. 1B, are designed such that a sharp corner is formed at the apex 16 of the right hand and left hand gear teeth. This sharp corner generates an undesirable stress concentration. Alternatively, when manufactured via milling, some herringbone gears are formed with a fillet radius at the apex. However, the fillet radius becomes a non-functional area of the gear teeth due to current manufacturing limitations, making the gear less efficient and heavier than desired. Such gears having a non-functional area are unsuitable for weight

restrictive aerospace applications. Furthermore, since neither of these methods allow the teeth to be finish ground to improve the surface finish, this makes them additionally unsuitable for aerospace applications.

[0031] Referring now to FIG. 2, an example of a herringbone gear 30 according to an embodiment of the invention is illustrated in more detail. In one embodiment, the gear 30 as described herein may be formed via a gear grinding machine as set forth in application PCT/US2015/011572, filed on January 15, 2015, the entire contents of which are incorporated herein by reference. It should be understood that in embodiments where the gear is intended for use in an aerospace application, the ground gear is a “high precision aerospace gear” having an American Gear Manufacturer’s Association (“AGMA”) class of 11 or higher.

[0032] The gear 30 includes a generally cylindrical body 32 having first and second axial faces 34, 36 opposite one another. A circumferential face 38 of the body 32 includes a first left hand array 40 of helical gear teeth 42. Similarly, the circumferential face 38 also includes a right hand array 50 of helical gear teeth 52, which is oppositely oriented with respect to the left hand helical 40. The first and second annular arrays 40, 50 converge such that each helical gear tooth 42 generally abuts a corresponding helical gear tooth 52.

[0033] A transition gear tooth 60 extends between each helical gear tooth 42 of the first annular array 40 and a corresponding helical gear tooth 52 of the second annular array 50. The transition gear tooth 60 includes a radius formed at the apex 61 that fluidly transitions between the gear teeth 42, 52 of the first and second annular arrays 40, 50 without an interruption in respective shapes of the helical gear teeth 42, 52 in the region of the abutment. More specifically, the transition gear tooth 60 is configured to merge tangentially with the helical gear teeth 42, 52 at the boundary defined there between. The radius of the transition gear tooth 60 is selected such that the involute form of the sides of a groove 63 between adjacent teeth 42, 52 within the transverse plane T remains constant across the width of the gear 30, including the helical gear teeth 42, 52 as well as the transition gear tooth 60. As a result, mating contact is configured to occur along the transition gear tooth 60 of the gear 30. The constant involute form within the groove 63 in the transverse plane additionally ensures conjugate motion while rolling through the entire surface area of the gear teeth 42, 52 (i.e., when an adjacent gear having teeth including a like involute form meshes with the groove 63).

[0034] As shown in FIG. 2, in order to maintain the involute form, the groove 63 has a constant distance between adjacent teeth 42, 52 in the normal plane when not in the

transition gear tooth 60, and a variable distance in the normal plane which increases in proximity to the apex 61.

[0035] A grinding spindle 70 for forming each of the gear teeth 42, 52, and transition gear tooth 60 is illustrated in more detail in FIGS. 3-5. In one embodiment, the spindle 70 may be configured to form the plurality of teeth 42, 52 and transition gear tooth 60 via electrochemical grinding. However, other types of grinding processes are also within the scope of the disclosure. As shown, the grinding spindle 70 rotates a grinding wheel 74. The grinding wheel 74 may have an involute profile to machine the groove 63 and sides of the gear teeth 42, 52. The spindle 70 and grinding wheel 74 are axially aligned and define a central longitudinal axis X of the spindle 70.

[0036] During a grinding operation, the central longitudinal axis X of the spindle 70 is arranged generally perpendicular to a rotational axis of the workpiece or gear 30. However, unlike conventional grinding wheels which have a longitudinal axis offset from and parallel to a surface of the gear 30, the spindle 70 is oriented such that the central longitudinal axis X of the spindle 70 extends through opposing sides of the workpiece 30. In addition, the grinding spindle 70 is configured to pivot within one or more planes to achieve a desired geometry. For example, as shown in the FIG. 3a, the axis X of the grinding spindle 70 is movable within a first plane and a second plane, arranged substantially perpendicular to the first plane.

[0037] The grinding spindle 70, and more particularly, the grinding wheel 74, may be maneuvered to create a constant involute form of at least a first gear tooth 42, apex transition gear tooth 60, and second gear tooth 52 in single or multiple operations or passes of the spindle 70 across a width of the gear 30. As illustrated in the FIGS. 4 and 5a-5b, the spindle 70 moves generally linearly along a path to create the groove 63 that defines a constant involute form of the sides of the first gear tooth 42 when viewed in a transverse plane (FIG. 5a). When creating the transition gear tooth 60, the normal plane, within which the grinding wheel 74 is positioned and is perpendicular to the groove 63, gradually rotates as the spindle 70 moves between second annular arrays 40, 50 until the normal plane is substantially aligned with the transverse plane at the apex 61. As the grinding wheel 74 moves through the transition 60, the longitudinal axis X of the grinding spindle 70 is rotated or varied in the first and second planes as shown in FIG. 3A to account for this continuous change in the orientation of the normal plane to maintain a constant involute form in a transverse plane within the transition gear tooth 60. The grinding wheel 74 then moves generally linearly along a path that defines a constant involute form of the second gear tooth 52 when viewed in

a transverse plane. Together, these movements comprise single or multiple passes or operations of the grinding spindle 70. This multi-axis movement is employed to maintain correct working tooth geometry, particularly in the apex transition gear tooth 60, where it may be machined in multiple passes. This operation may be repeated in the same direction, or alternatively, in reverse to form the plurality of gear teeth 42, 52 and transition gear tooth 60 of the gear 30. In one embodiment, the finish ground herringbone gear 30 has a surface finish of about 10 Ra.

[0038] A herringbone gear 30 having the transition gear tooth 60 as described herein is stronger in bending. Elimination of a non-functional apex gap 16 shown in FIG. 1A provides a reduction in weight. The resulting weight reduction improves the performance of aircraft, including reduced fuel consumption, longer flight range, increased payload, and higher speeds. In addition, prior methods of manufacturing herringbone gears resulted in a surface finish of about 100-150 Ra. However, a finish ground high precision aerospace gear as disclosed herein would have a surface finish of about 10 Ra.

[0039] While the invention has been described in detail in connection with only a limited number of embodiments, it should be readily understood that the invention is not limited to such disclosed embodiments. Rather, the invention can be modified to incorporate any number of variations, alterations, substitutions or equivalent arrangements not heretofore described, but which are commensurate with the spirit and scope of the invention. By way of example, aspects of the invention can be used in non-aerospace gear applications, such as for helical gears used in automotive, maritime, industrial, elevator and locomotive applications. Additionally, while various embodiments of the invention have been described, it is to be understood that aspects of the invention may include only some of the described embodiments. Accordingly, the invention is not to be seen as limited by the foregoing description, but is only limited by the scope of the appended claims.

## CLAIMS:

What is claimed is:

1. A herringbone gear, comprising:
  - a cylindrical body having a circumferential face having a width;
  - a first helical gear tooth on the circumferential face having a first configuration;
  - a second helical gear tooth on the circumferential face having a second configuration other than the first configuration; and
  - a transition on the circumferential face extending between the first helical gear tooth and the second helical gear tooth such that an involute form taken within a transverse plane of the circumferential face which remains constant over the width.
2. The herringbone gear according to claim 1, wherein the first configuration and the second configuration are opposites.
3. The herringbone gear according to either claim 1 or claim 2, wherein the transition includes a radius.
4. The herringbone gear according to any of the preceding claims, wherein conjugate motion occurs over an entire surface of the first helical gear tooth, the transition gear tooth and the second helical gear tooth when meshed with a corresponding herringbone gear.
5. The herringbone gear according to any of the preceding claims, wherein the herringbone gear is installed within a power transmission assembly.
6. The herringbone gear according to any of the preceding claims, wherein the power transmission assembly is part of a rotary wing aircraft.
7. A method of forming a double-helical gear, comprising:
  - forming a portion of an aligned first gear tooth, transition gear tooth and second gear tooth via a single pass of a spindle such that an involute form taken within a transverse plane remains constant over a width of the gear.
8. The method according to claim 7, wherein a longitudinal axis of the spindle is arranged generally perpendicular to an axis of rotation of the gear, the longitudinal axis extending through the gear.
9. The method according to claim 8, wherein forming the transition includes varying an orientation of the longitudinal axis of the spindle relative to the gear to maintain a constant involute form in the transition.
10. The method according to claim 9, wherein a portion of the first gear tooth is formed by moving the spindle generally linearly.

11. The method according to claim 9, wherein a portion of the second gear tooth is formed by moving the spindle generally linearly.
12. The method according to claim 8, wherein the spindle includes a grinding wheel configured to rotate about the longitudinal axis of the spindle.
13. The method according to claim 8, wherein the spindle is configured to removed material from the gear via electrochemical grinding.

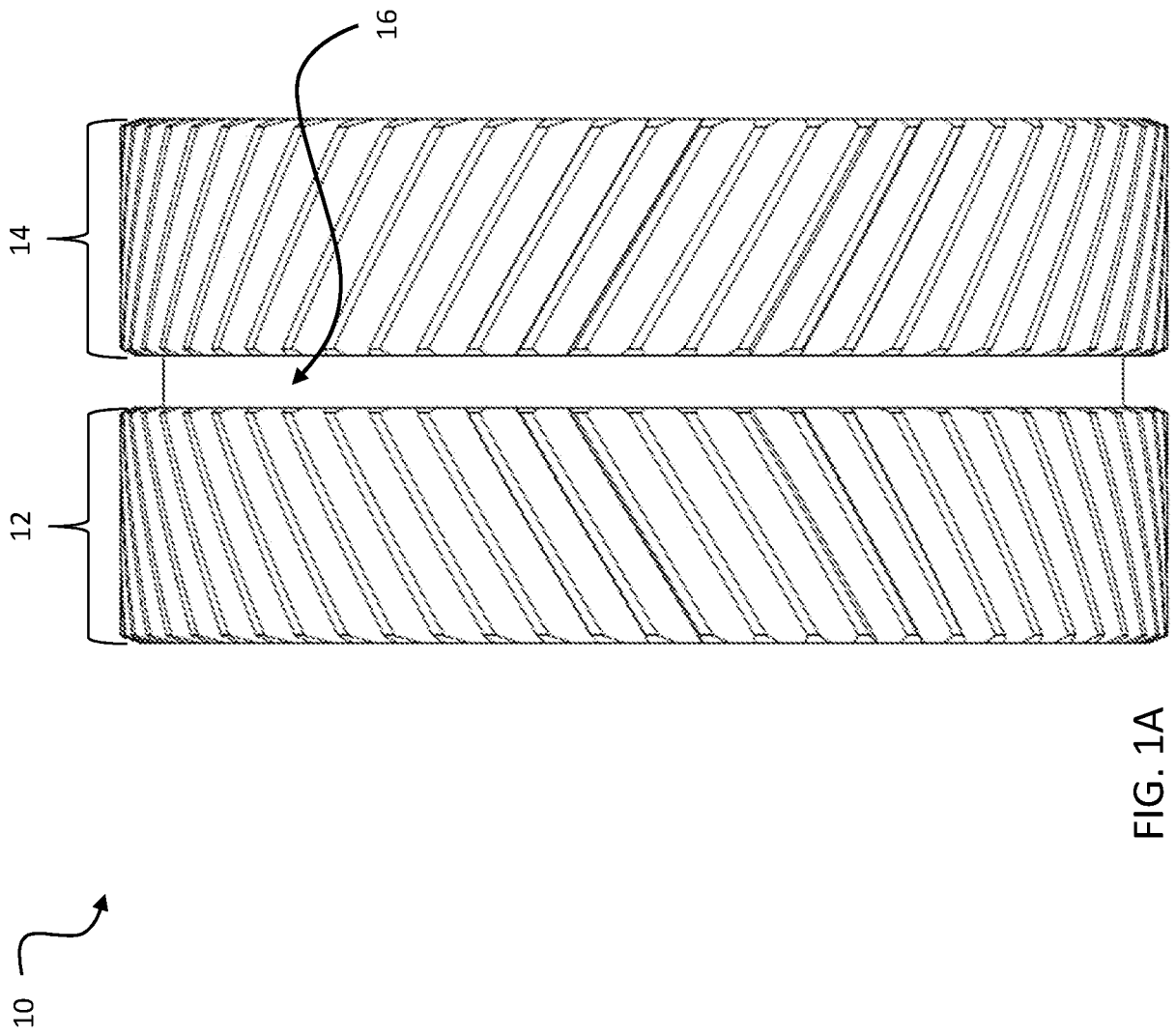

FIG. 1A

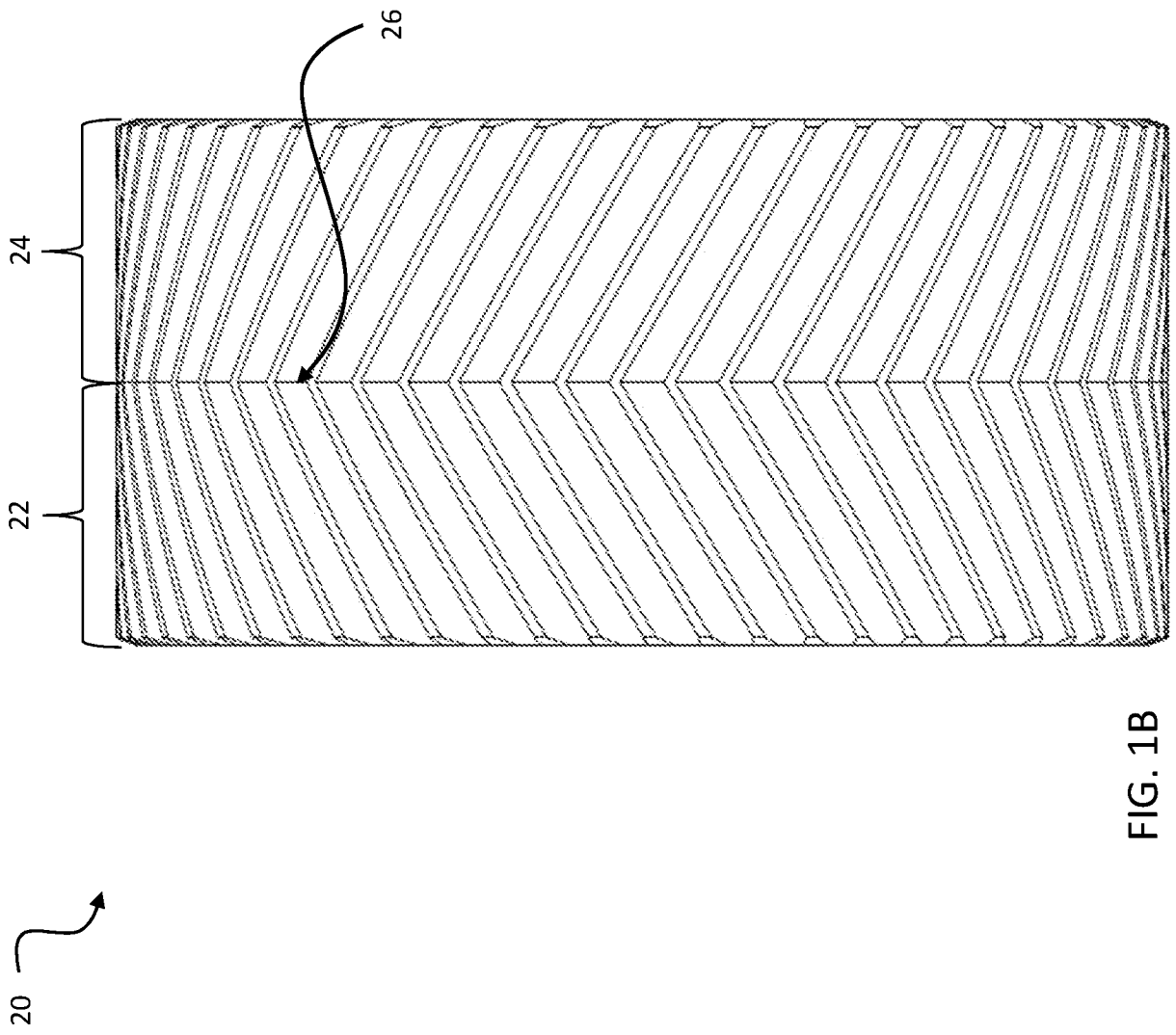

FIG. 1B

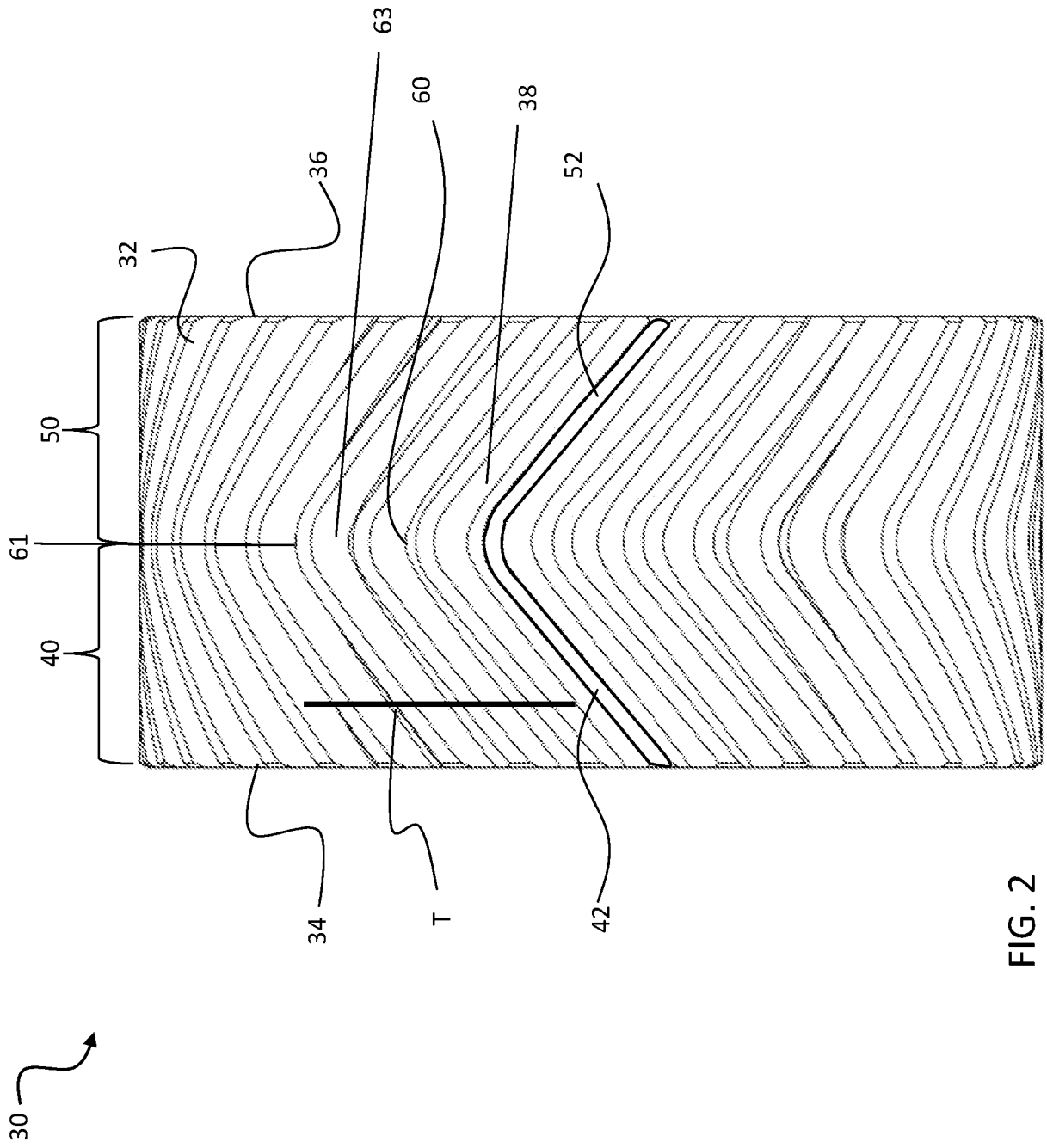
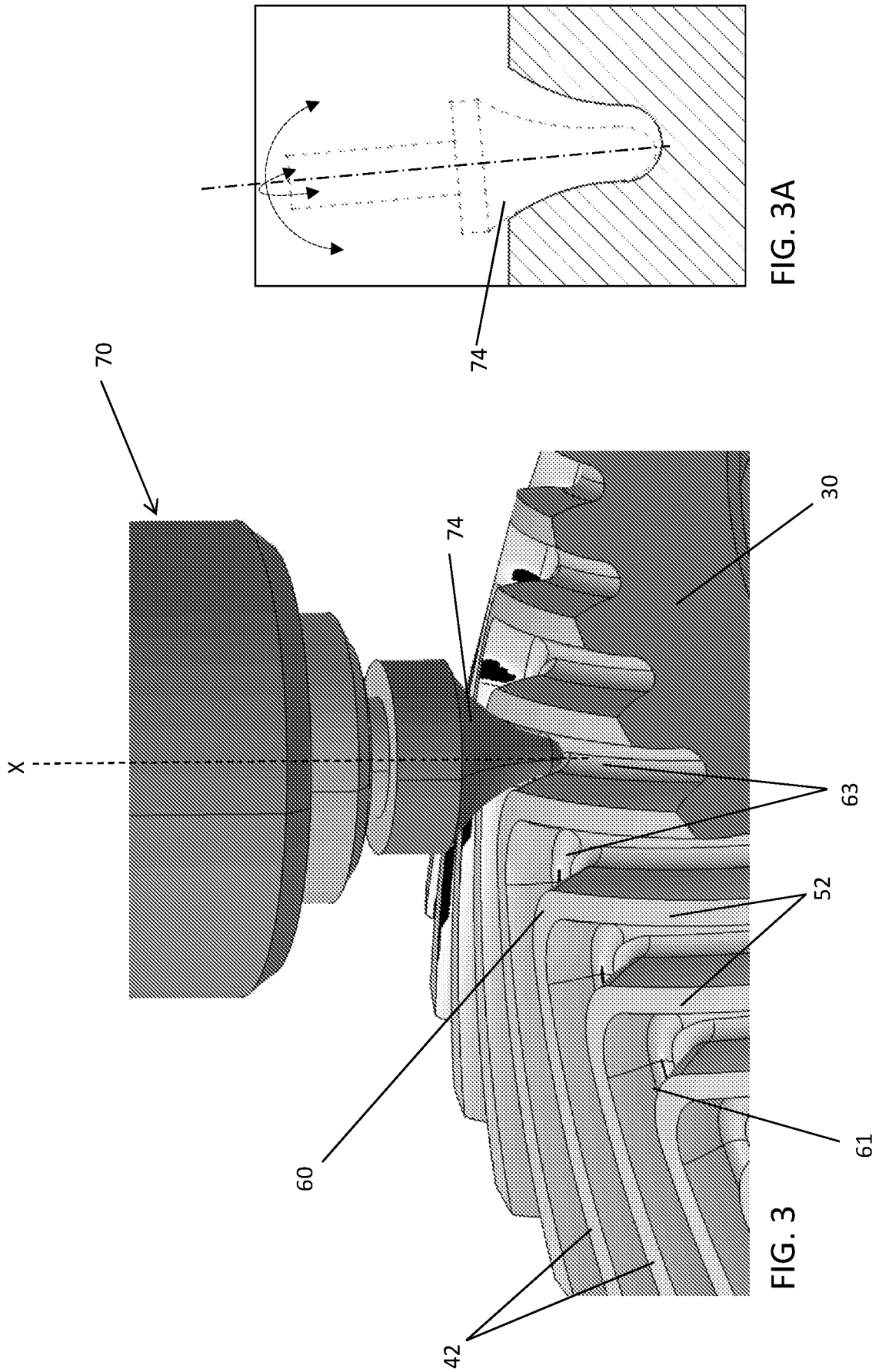

FIG. 2



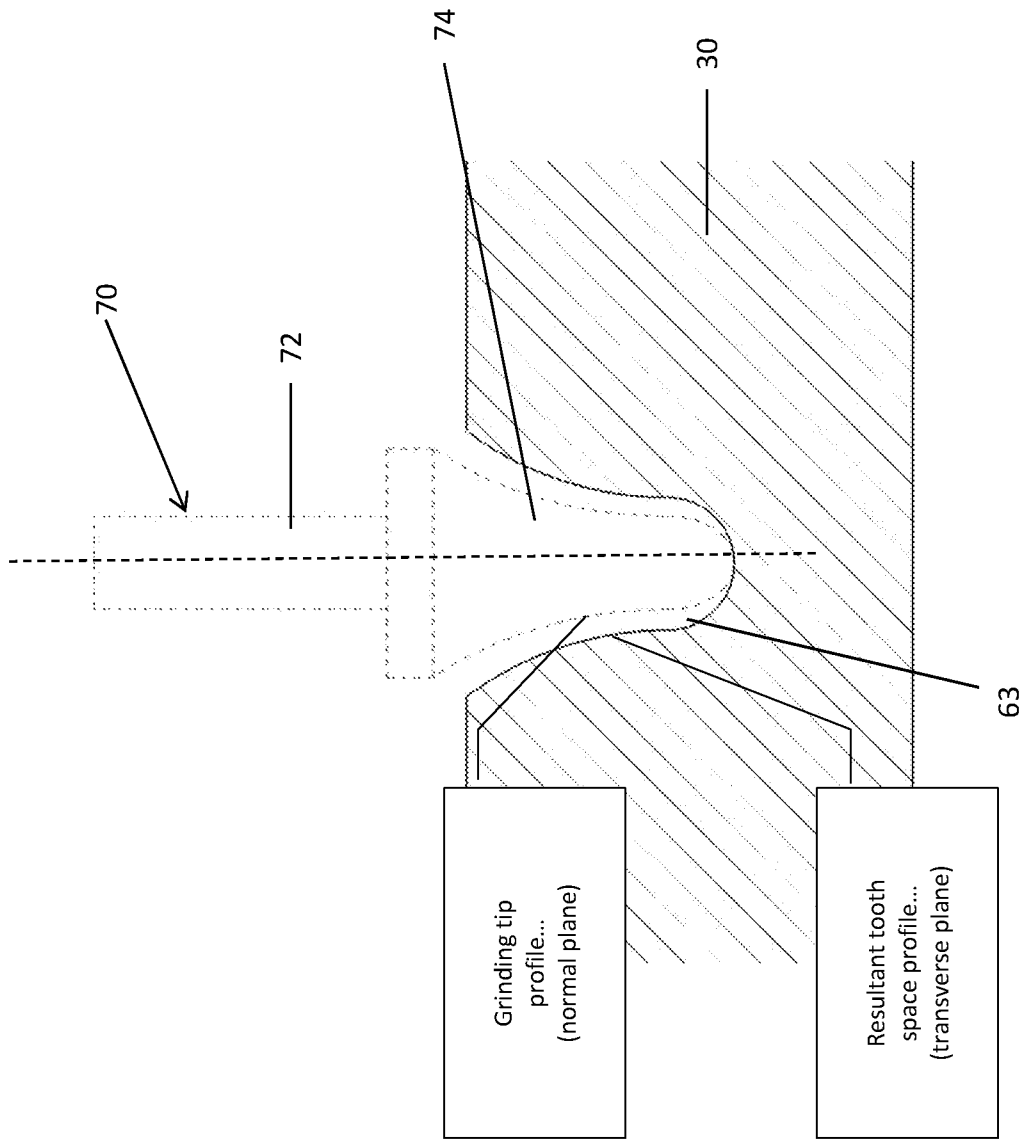

FIG. 4

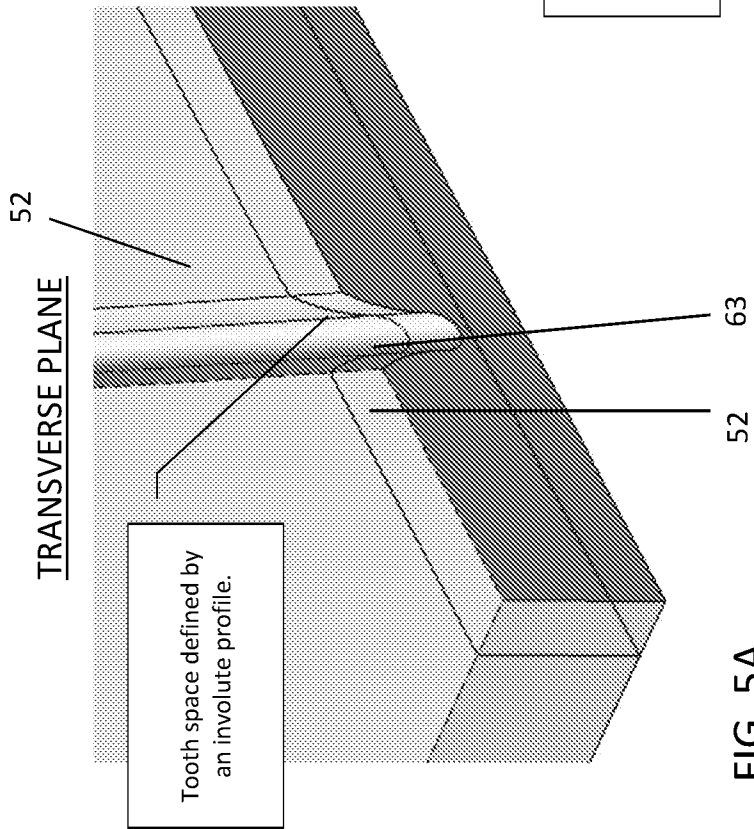

FIG. 5A

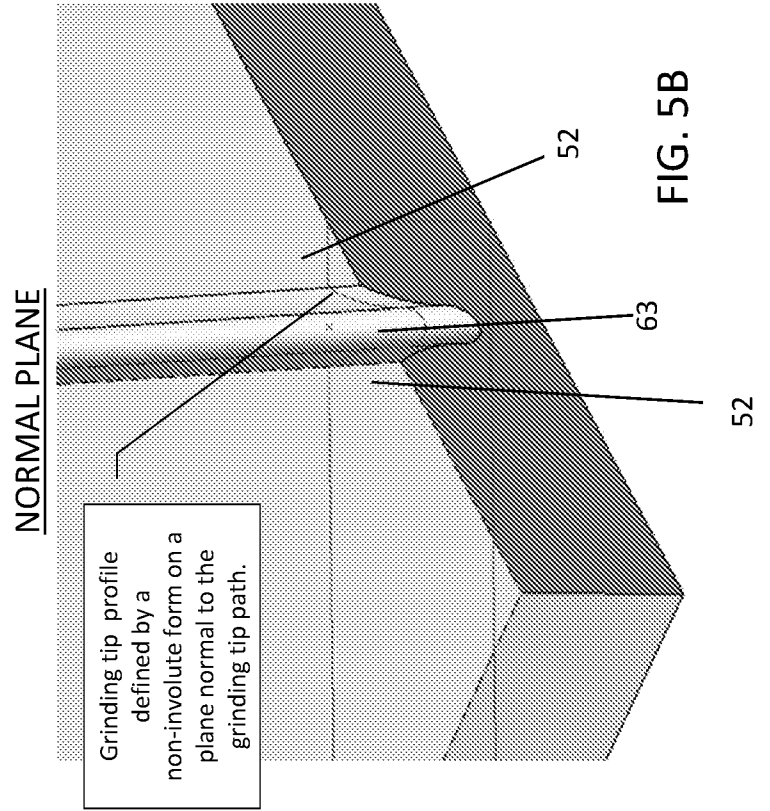

FIG. 5B

## INTERNATIONAL SEARCH REPORT

International application No.

PCT/US2017/015586

## A. CLASSIFICATION OF SUBJECT MATTER

IPC(8) - F16H 55/08; B23F 7/00; B23H 9/00; B23P 15/14; F16H 1/08; F16H 55/02; F16H 55/06 (2017.01)

CPC - F16H 55/0806; B23F 7/00; B23H 9/003; B23P 15/14; F16H 1/08; F16H 55/02; F16H 55/06; F16H 55/08; F16H 55/17 (2017.02)

According to International Patent Classification (IPC) or to both national classification and IPC

## B. FIELDS SEARCHED

Minimum documentation searched (classification system followed by classification symbols)

See Search History document

Documentation searched other than minimum documentation to the extent that such documents are included in the fields searched

USPC - 29/893; 29/893.35; 74/457; 74/458; 74/462 (keyword delimited)

Electronic data base consulted during the international search (name of data base and, where practicable, search terms used)

See Search History document

## C. DOCUMENTS CONSIDERED TO BE RELEVANT

| Category* | Citation of document, with indication, where appropriate, of the relevant passages  | Relevant to claim No. |
|-----------|---|-----------------------|
| X         | US 2015/0202705 A1 (SIKORSKY AIRCRAFT CORPORATION) 23 July 2015 (23.07.2015) entire document  | 1-3, 7, 8, 12, 13     |
| A         | DE 20 2014 007 647 U1 (UNIVERSITÄT STUTTGART KÖRPERSCHAFT DES ÖFFENTLICHEN RECHTS) 22 January 2015 (22.01.2015) see machine translation | 1-3, 7-13             |
| A         | US 2011/0302783 A1 (NAGATA et al) 15 December 2011 (15.12.2011) entire document   | 1-3, 7-13             |
| A         | US 2003/0056371 A1 (HONDA) 27 March 2003 (27.03.2003) entire document   | 1-3, 7-13             |

 Further documents are listed in the continuation of Box C.

 See patent family annex.

\* Special categories of cited documents:

"A" document defining the general state of the art which is not considered to be of particular relevance

"E" earlier application or patent but published on or after the international filing date

"L" document which may throw doubts on priority claim(s) or which is cited to establish the publication date of another citation or other special reason (as specified)

"O" document referring to an oral disclosure, use, exhibition or other means

"P" document published prior to the international filing date but later than the priority date claimed

"T" later document published after the international filing date or priority date and not in conflict with the application but cited to understand the principle or theory underlying the invention

"X" document of particular relevance; the claimed invention cannot be considered novel or cannot be considered to involve an inventive step when the document is taken alone

"Y" document of particular relevance; the claimed invention cannot be considered to involve an inventive step when the document is combined with one or more other such documents, such combination being obvious to a person skilled in the art

"&amp;" document member of the same patent family

Date of the actual completion of the international search

21 March 2017

Date of mailing of the international search report

17 APR 2017

Name and mailing address of the ISA/US

Mail Stop PCT, Attn: ISA/US, Commissioner for Patents  
P.O. Box 1450, Alexandria, VA 22313-1450  
Facsimile No. 571-273-8300

Authorized officer

Blaine R. Copenheaver

PCT Helpdesk: 571-272-4300  
PCT OSP: 571-272-7774

INTERNATIONAL SEARCH REPORT

International application No.  
PCT/US2017/015586

**Box No. II Observations where certain claims were found unsearchable (Continuation of item 2 of first sheet)**

This international search report has not been established in respect of certain claims under Article 17(2)(a) for the following reasons:

- 1.  Claims Nos.:  
because they relate to subject matter not required to be searched by this Authority, namely:
  
- 2.  Claims Nos.:  
because they relate to parts of the international application that do not comply with the prescribed requirements to such an extent that no meaningful international search can be carried out, specifically:
  
- 3.  Claims Nos.: 4-6  
because they are dependent claims and are not drafted in accordance with the second and third sentences of Rule 6.4(a).

**Box No. III Observations where unity of invention is lacking (Continuation of item 3 of first sheet)**

This International Searching Authority found multiple inventions in this international application, as follows:

- 1.  As all required additional search fees were timely paid by the applicant, this international search report covers all searchable claims.
- 2.  As all searchable claims could be searched without effort justifying additional fees, this Authority did not invite payment of additional fees.
- 3.  As only some of the required additional search fees were timely paid by the applicant, this international search report covers only those claims for which fees were paid, specifically claims Nos.:
  
- 4.  No required additional search fees were timely paid by the applicant. Consequently, this international search report is restricted to the invention first mentioned in the claims; it is covered by claims Nos.:

- Remark on Protest**
- The additional search fees were accompanied by the applicant's protest and, where applicable, the payment of a protest fee.
  - The additional search fees were accompanied by the applicant's protest but the applicable protest fee was not paid within the time limit specified in the invitation.
  - No protest accompanied the payment of additional search fees.