

Oct. 17, 1939.

H. T. SWORTWOOD ET AL

2,176,231

PUMP

Filed Nov. 27, 1937

FIG. 1

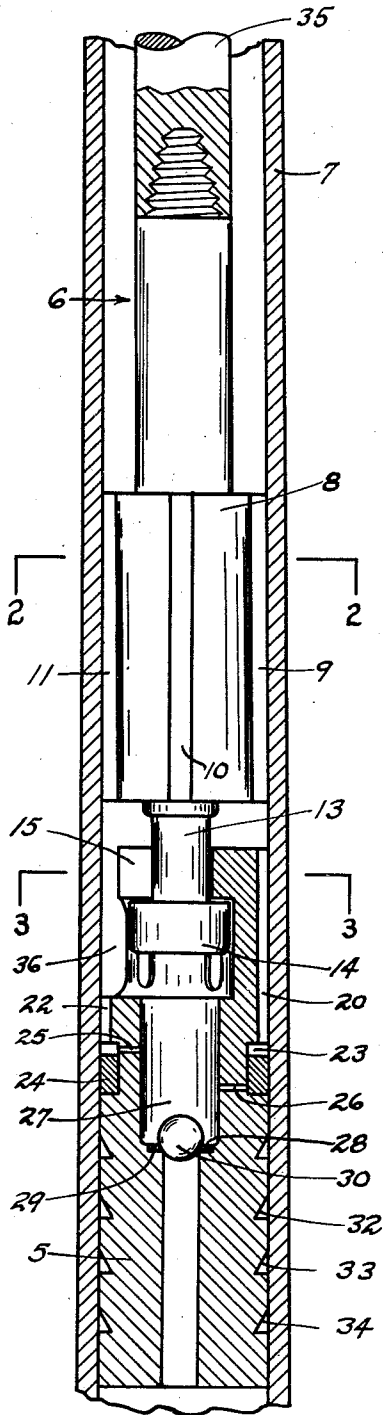

FIG. 2

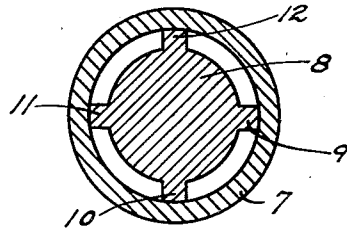

FIG. 3

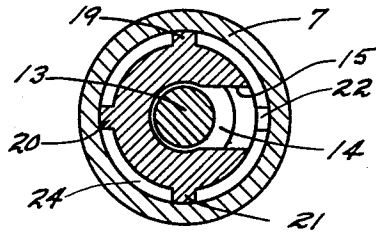
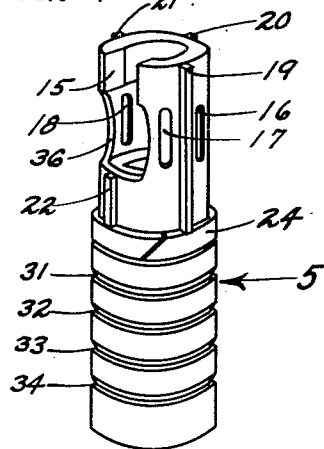

FIG. 4



HARRY T. SWORTWOOD
HENRY G. OSBURN
INVENTORS

BY Hubert Miller
ATTORNEY

UNITED STATES PATENT OFFICE

2,176,231

PUMP

Harry T. Swortwood and Henry G. Osburn,
Oklahoma City, Okla.

Application November 27, 1937, Serial No. 176,796

2 Claims. (Cl. 103—225)

The invention herein described is an improvement on United States Patent No. 2,090,209, issued August 17, 1937, and relates to reciprocating plunger type pumps, and more particularly to plungers for such pumps. With pumps of present design, when the plunger rings or leathers become worn, it is necessary to pull the plunger and either return it to the factory for replacement of the sleeve, or send it to a machine shop for replacement of the plunger sleeve, which replacement requires some three to four hours labor, and actually means that the pump is out of operation for a considerable period of time.

The chief object of our invention is to obviate the above difficulty, by providing a plunger made in two easily separable parts so that the entire plunger may be withdrawn from its barrel, the sleeve removed without the use of tools, and a new sleeve substituted, and the pump again placed in operation immediately.

Another object of the invention is to provide such a plunger which includes the advantages of an expansible sealing element.

Other objects of the invention are to provide a novel swivel arrangement between the sealing portion of the plunger and the operating stem, thus permitting the use of a "stiff socket" tool joint for connecting the plunger to an operating rod or cable, thus preventing kinking of the cable, or torsional strain on a string of operating rods; a plunger which is so constructed as to provide unobstructed circulation of liquid through the plunger as it passes downward in its barrel; and one which includes a means for dislodging the plunger in case it becomes stuck in its barrel due to grains of sand lodging between the plunger and the barrel.

Other objects of the invention will be fully and comprehensively understood from a consideration of the following detailed description when read in connection with the accompanying drawing which forms a part of this application. The drawing is to be considered illustrative only.

Referring to the drawing:

Figure 1 is a side sectional view of our plunger in position within a pump barrel;

Figure 2 is a horizontal section taken along the line 2—2 of Figure 1;

Figure 3 is a horizontal section taken along the line 3—3 of Figure 1; and,

Figure 4 is a perspective view of the lower portion of the plunger, and is hereinafter called the sleeve.

Like characters of reference designate like parts in all the figures.

Our plunger consists of two main elements, the plunger sleeve or sealing member, and the plunger operating stem, which are respectively designated by the numerals 5 and 6. The upper end of the stem 6 is of considerably smaller diameter than the interior diameter of the pump barrel 7, and is threaded to receive the lower end of a tool joint 35.

Intermediate its ends, the stem 6 is provided with a guide member 8, which in turn is provided with a plurality of spaced longitudinally extending guides 9, 10, 11 and 12. The portion 8 is of less diameter than the interior of the pump barrel 7, as clearly shown in Figure 2, thus permitting free circulation of fluid past the member 8 between the guides 9, 10, 11 and 12. The guides 9, 10, 11 and 12 serve to maintain the stem 6 in a central position within the barrel 7 at all times, by their contact with the inner wall of the barrel.

At the opposite end of the guide member 8 the stem 6 is reduced in diameter for a short distance, as designated by the numeral 13, and this reduced portion 13 is provided at its extreme end with a substantially cylindrical male swivel joint member 14, which is of considerably larger diameter than the portion 13.

Within the upper end of the sleeve-like sealing member 5 is formed a complementary swivel socket for receiving the male swivel member 14. The socket, at its extreme upper end is only slightly larger in diameter than the diameter of the portion 13, while therebelow, the socket is enlarged to a diameter only slightly larger than the diameter of the member 14. A side slot 15 communicating with a larger side opening 36, together form a side entrance for the lower end of the stem into the upper end of the sleeve 5. A plurality of longitudinal slots 16, 17, and 18 are provided in the wall of the sleeve 5 adjacent the socket in which the lock member 14 seats, to increase fluid circulation area through the upper end of the sleeve. The upper end of the sleeve 5 is also provided with longitudinally extending guides 19, 20, 21 and 22, which serve to centrally position the sleeve within the barrel 7.

Immediately below its socket end the sleeve 5 is provided with a ring groove 23 within which is seated a sealing ring 24, which is of the expansible type and is preferably of metal. If desired, a plurality of these grooves and rings may be used without changing the principle of

our invention. A plurality of fluid passages 25 and 26 are provided in the wall of the sleeve 5, some of which passages communicate with the upper end of the ring groove, and some communicate with the lower end of the ring groove. The groove being wider than the ring, permits the ring a limited slidable movement therein. As the entire plunger is drawn upward in the barrel, and fluid is lifted above it, the ring slides to the position shown in Figure 1. The fluid passages 25 then permit fluid to tightly seal the space in the groove immediately above the ring, and the fluid passages 26 permit fluid to contact the inner surface of the ring, expanding it and forcing it tightly against the inner wall of the barrel 7.

The central bore 27 of the sleeve 5 communicates at its upper end with the swivel socket, and intermediate its ends is reduced abruptly at 28, the reduced bore continuing to the extreme lower end of the sleeve 5. The shoulder at 28 is formed to receive a removable valve seat 29 which may be tightly pressed into position, or otherwise suitably secured in a position concentric with the bore. This shoulder must necessarily be located at a point below the lowermost ring if it is desired to use a plurality of sealing rings.

The seat 29 seats a ball valve 30 which tightly seals the central bore through the plunger during its upward stroke. Below the ring groove 23, the sleeve 5 may be of any suitable design, but we prefer to make it of substantially the same diameter as the interior diameter of the barrel 7 and provide it with a plurality of grooves 31, 32, 33, and 34.

It will be clearly seen that when the male swivel member 14 is inserted through the slot 15 and the side opening 35 into the socket in the upper end of the sleeve 5, and the complete plunger is placed within the barrel 7, the stem and the sleeve are held by their respective guides against relative radial movement, and it is, therefore, impossible for these two members to become disconnected. In case it is desired to replace the sleeve the entire plunger is simply withdrawn from the barrel, at which time the locking element 14 and its stem 13 may be withdrawn through the side opening from the socket in the upper end of the sleeve 5, and a new sleeve substituted in the same manner, as above described.

Operation

In operation, the plunger is adapted to be reciprocated within the barrel by means of a string of sucker rods or by a cable, either of which may be connected to the upper end of the stem 6 by means of a usual tool joint 35. As the plunger is drawn upward in the barrel, the valve 30 seats on its seat 29 and fluid is drawn in through any suitable valve (not shown) in the lower end of the barrel 7. When the upward motion of the plunger ceases, the fluid drawn into the barrel during the upward motion is trapped by the valve through which it enters, and as the plunger moves downward the trapped fluid passes upward through the central bore of the sleeve, lifts the valve 30 from its seat, passes on upward through the swivel socket, out through the slots 16, 17, and 18 in the wall of the socket connection, upward past the guide member 8 through the space between its guides 9, 10, 11 and 12, and on up into the production tubing which communicates with the upper end of the barrel 7. On each upward stroke the plunger must lift the weight of the fluid above it in the barrel and in the production tubing. At a consid-

erable depth beneath the surface of the earth the weight of the fluid lifted by the plunger on each up stroke is considerable, and as has previously been mentioned, the full weight of the fluid is utilized to expand the ring 24 tightly against the barrel walls. This arrangement takes care of wear on the outer surface of the ring 24. As that surface wears off the ring is simply expanded a slightly greater degree by the weight of the fluid above it, and continues to maintain a tight seat against the barrel wall during the up stroke of the plunger regardless of its wear.

We also wish to call attention to the fact that the swivel socket may be of somewhat greater length than the length of the male swivel member 14, which arrangement permits relative longitudinal movement between the members 5 and 6. Should sand or other foreign matter lodge between the sleeve and the barrel wall, "sticking" the sleeve, the operating stem can be used as a hammer to dislodge the sleeve.

While we have described and illustrated a specific embodiment of our invention, we are aware that numerous alterations and changes may be made therein and we do not wish to be limited except by the prior art and the scope of the appended claims.

We claim:

1. The combination with a cylindrical pump barrel, of a plunger adapted to be reciprocated therein, said plunger comprising: a sleeve member having a swivel socket formed in its upper end, said socket having a top opening and a larger side opening, the socket being of greater diameter adjacent the side opening than the diameter of said top opening; a sealing ring carried exteriorly by said sleeve intermediate its ends for sealing against the wall of the barrel; a fluid operable ball check valve positioned to normally close the central bore of said sleeve member; and an operating stem, its upper end adapted for connection to an operating cable or rod, and including an intermediate guide member for maintaining the stem in a central position within the barrel, and a male swivel member for complementally fitting within the socket in the upper end of said sleeve to connect the sleeve and stem together, whereby the sleeve and its stem are permitted relative rotational and limited relative longitudinal movement, the barrel wall preventing relative radial movement.

2. The combination with a pump barrel, of a plunger adapted to be reciprocated therein, said plunger comprising: a sleeve having an open sided swivel chamber adjacent one of its ends and a bore of relatively smaller diameter in that end communicating with said swivel chamber; an annular ring groove formed in the exterior wall of the sleeve; an expansion ring seated in said ring groove for sealing against the barrel wall; a fluid operable ball check valve positioned within said sleeve below said swivel chamber; integral guides carried externally by the sleeve for keeping the sleeve in a central position within the barrel; an operating stem, one end of which is of a size and shape to complementally fit within said swivel chamber and to enter said chamber through its open side, and the other end of which is adapted for connection to a plunger operating line; and integral guides carried by the stem for contacting the barrel wall and keeping the stem in a central position therein.

HARRY T. SWORTWOOD.
HENRY G. OSBURN.