

No. 816,413.

PATENTED MAR. 27, 1906.

J. S. WINGET.  
CIGAR MOISTENER.  
APPLICATION FILED MAR. 15, 1905.

2 SHEETS—SHEET 1.

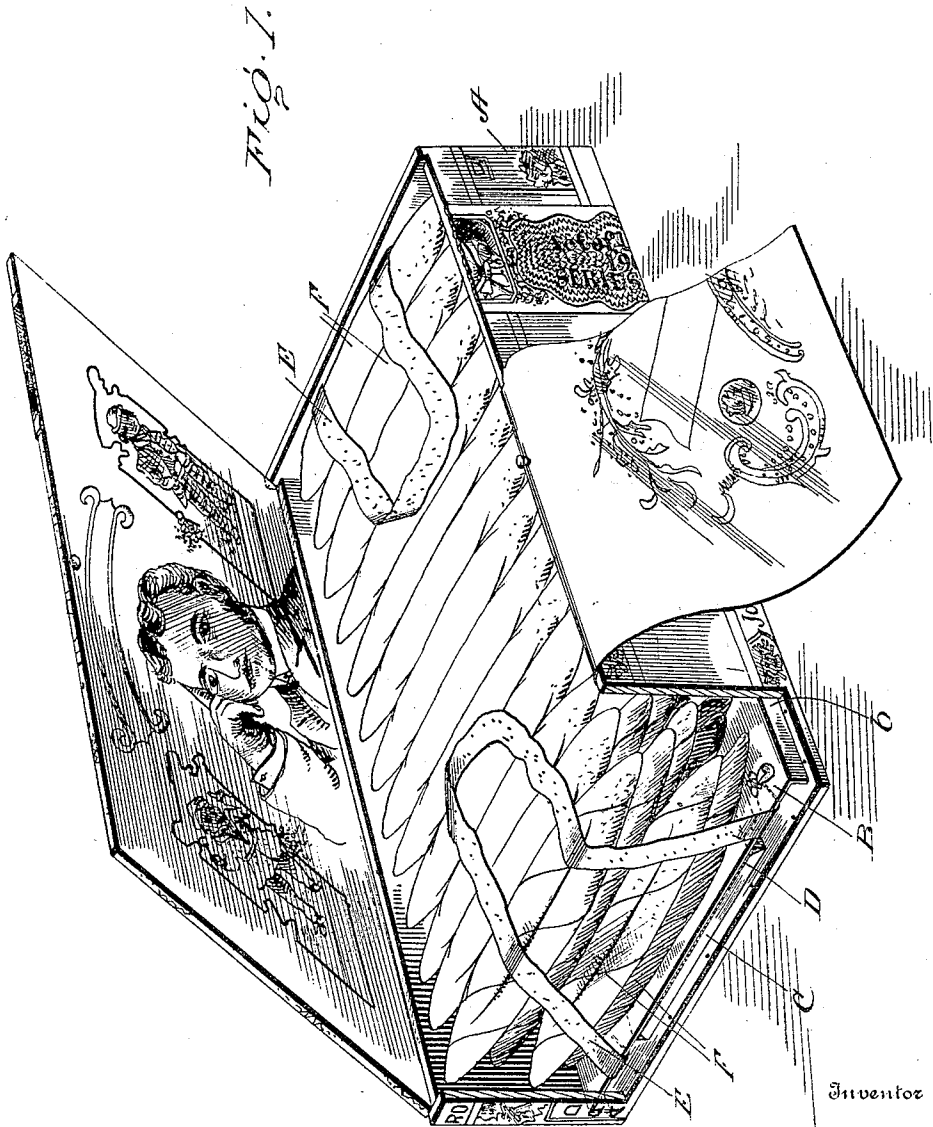

Inventor

Witnesses

*Jno. Imine*  
*C. P. Wright, Jr.*

*J. S. Winget*

By

*A. S. Patterson,*

Attorney

No. 816,413.

PATENTED MAR. 27, 1906.

J. S. WINGET.  
CIGAR MOISTENER.

APPLICATION FILED MAR. 15, 1905.

2 SHEETS—SHEET 2.

Fig. 2.

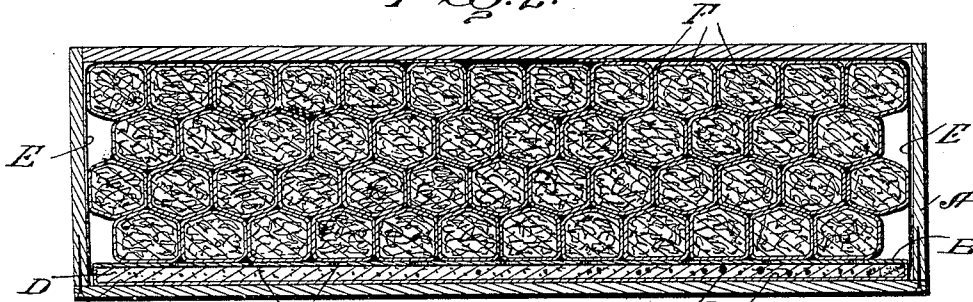

Fig. 3.

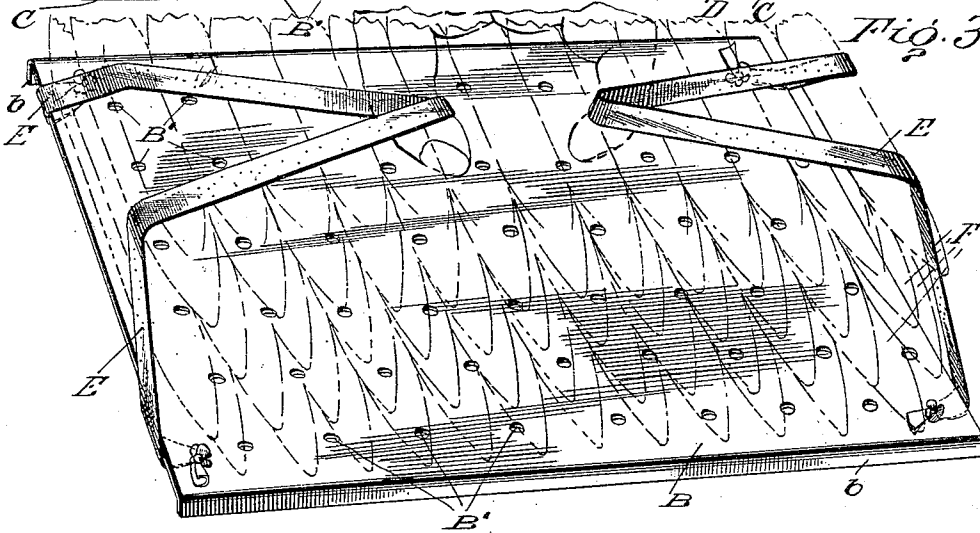
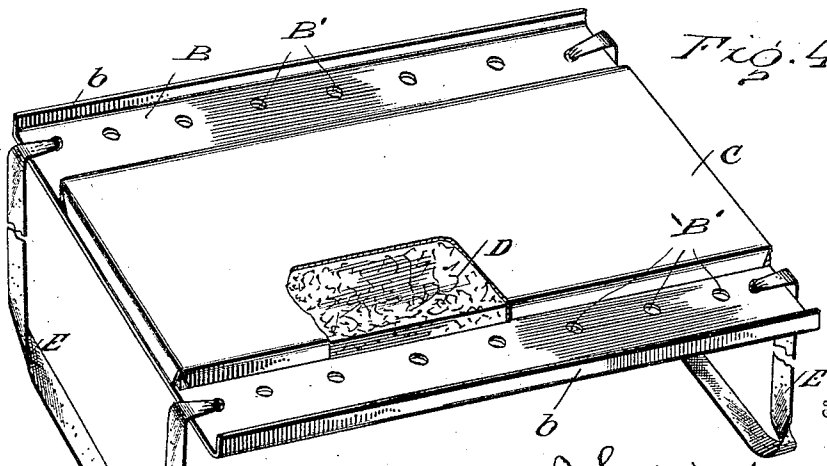

Fig. 4.



Witnesses  
Geo. Amiri  
C. P. Wright, Jr.

By

J. S. Winget,  
A. S. Pattison

Inventor

Attorney

# UNITED STATES PATENT OFFICE.

JASPER STANLEY WINGET, OF YORK, PENNSYLVANIA.

## CIGAR-MOISTENER.

No. 816,413.

Specification of Letters Patent.

Patented March 27, 1906.

Application filed March 15, 1905. Serial No. 250,247.

*To all whom it may concern:*

Be it known that I, JASPER STANLEY WINGET, a citizen of the United States, residing at York, in the county of York and State of Pennsylvania, have invented certain new and useful Improvements in Cigar-Moisteners, of which the following is a specification, reference being had therein to the accompanying drawings.

My invention relates to improvements in cigar-moisteners.

One object of my invention is to provide an original manufacturer's selling-box constructed to hold a predetermined number of cigars and also to contain a moistener, so that the original manufacturer's cigar-package is produced with means whereby the purchaser may keep the cigars therein moist until used.

A further object of my invention is to provide an original cigar-package with a moistener so arranged and constructed that the cigars can be removed as a body in their packed relation to permit the pad to be moistened and the cigars readily replaced in the package.

In the accompanying drawings, Figure 1 is a perspective view of a manufacturer's original cigar-box with the end broken away, showing my device therein and the seal broken and the cover raised ready to be used by the consumer. Fig. 2 is a longitudinal vertical sectional view of my device placed in a cigar-box and the cigars packed therein. Fig. 3 is a perspective view of the false bottom removed with the cigars in dotted lines thereon held by the tapes. Fig. 4 is an inverted perspective view of the false bottom with the moistener in position therein.

Referring now to the drawings, A represents the manufacturer's original cigar-box, which is made slightly larger than usual, so that my improved moistener may be readily placed therein and the cigars packed in the box in the usual manner. The preferred form of my invention consists in placing in said box A a false bottom B, which is of a size to snugly cover the entire bottom of the box. The said bottom B consists of a thin sheet of suitable material and has its sides turned downward at *b*, which forms supporting means for supporting the false bottom a slight distance above the bottom of the box and forming a space thereunder for receiving the moistening-pad. This pad consists of an elongated receptacle C in the form of an ob-

long shallow pan, which is of a width considerably less than that of the cigar-box, so that the downwardly-turned sides *b* of the false bottom will rest upon the bottom of the box. The said receptacle C is adapted to receive the moistening-pad D, which may be in the form of blotting-paper or any other absorbent material D. The said receptacle C extends the entire length of the cigar-box and is of a depth equal to that of the downwardly-turned sides *b* of the false bottom, and thus serves the additional function of a support for the center of the false bottom to prevent the same from being bent downward by the pressure applied during the packing of the cigars. By this structure it will be seen that the moisture from the pad does not come in direct contact with the bottom of the box, and thus prevents the same from becoming warped. The false bottom, as before described, snugly fits and covers the entire bottom of the box, and in order to allow the moisture to thoroughly and evenly moisten all of the cigars I provide the same with a series of openings B', which may be arranged in any order, but preferably staggering, as shown. In order to remove the false bottom and also retain the cigars F at the same time in their packed relation for moistening the pad, I provide each end of the false bottom with a loop E of some flexible material, such as tape or ribbon, and the ends of said loops are secured adjacent the sides, so that the bottom can be readily removed without tilting, and at the same time the cigars F are firmly held upon the false bottom when the same is removed.

My moistener is adapted to be packed in each box of cigars at the factory and is so cheaply constructed that it adds practically nothing to the cost of the cigars. The pad is first placed in the bottom of the box without moistening, as cigars need no moistening until after the box is opened to be used. The false bottom is then placed therein, with the loops extended upward and turned over the ends of the cigar-box. The cigars are next placed in the box and the necessary pressure is applied for firmly packing the same in the box, and after this is done the ends of the loops are turned over upon the cigars and the cover closed and the box sealed in the usual manner to be sold. After the consumer opens the box and it is desired to moisten the pad the ends of the loops are drawn together, which engages both ends of the cigars at each

end of the box and firmly holds them in their packed position and prevents them from sliding from the false bottom, and by drawing upwardly upon the loops the false bottom is raised and the contents of the box readily removed, whereby the pad is exposed and may be readily moistened. The false bottom, together with the packed cigars, can be readily replaced within the box, and this operation can be repeated as often as desired. The false bottom also forms a means for protecting the cigars from direct contact with the moistener,

Having thus described my invention, what I claim, and desire to secure by Letters Patent, is—

1. An original cigar-package, comprising an original manufacturer's box constructed to contain a predetermined number of cigars and enlarged to receive a false bottom, a false bottom within said box, and having a downwardly-extending flange supporting the same above the bottom of the box, and a pad-containing receptacle of a depth equal to that of the flanges of the false bottom, and holding a moistening-pad and constructed to support the false bottom against pressure used for packing the cigars in the box.

2. An original cigar-package, comprising an original manufacturer's box constructed to contain a predetermined number of cigars and enlarged to receive a false bottom, a false bottom removably supported within the box, means for supporting the false bottom above the bottom of the box and forming a pad-containing space below the same, and a pad-containing receptacle holding a moistening-pad and constructed to support the false bottom against pressure used for packing the cigars in the box.

3. An original cigar-package, comprising an original manufacturer's box constructed to contain a predetermined number of cigars

and enlarged to receive a false bottom, a false bottom within said box, and a pad-containing receptacle below said false bottom and adapted to hold a moistening-pad and constructed to support the false bottom against pressure used for packing the cigars in the box.

4. An original cigar-package, comprising an original manufacturer's selling-box constructed to contain a predetermined number of cigars, a false bottom within the box and supported above the bottom thereof, a pad below said false bottom, and loops having their ends secured to the ends of the false bottom and extending upwardly over the cigars at the end and top when the tapes are drawn together whereby the cigars are firmly clamped upon the false bottom against an upward or sidewise movement, and the false bottom can be removed and the cigars held in their packed relation thereon.

5. An original cigar-package, comprising an original manufacturer's selling-box, constructed to contain a predetermined number of cigars, a false bottom within the box and supported above the bottom thereof, a pad below said false bottom, and flexible tapes secured to the ends of the false bottom and extending upward over the cigars and adapted to be grasped by one hand and drawn together over the ends and top of the cigars for removing the false bottom upward and out of the top of the box and holding the cigars thereon, whereby the pad may be moistened and the false bottom replaced within the box with the cigars held in the packed relation thereon.

In testimony whereof I affix my signature in presence of two witnesses.

JASPER STANLEY WINGET.

Witnesses:

DONALD H. YOST,  
JACOB E. WEAVER.