

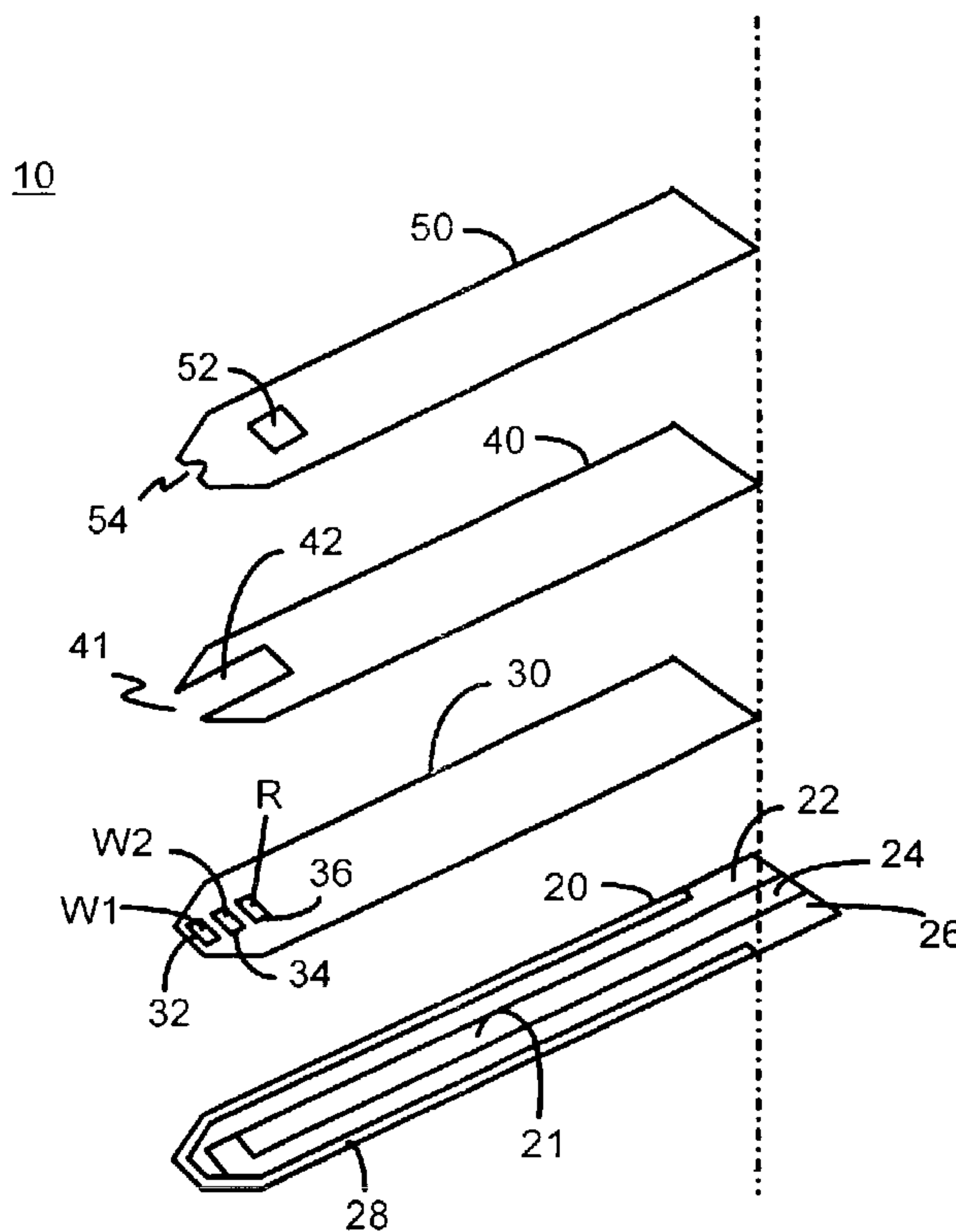

(86) Date de dépôt PCT/PCT Filing Date: 2003/04/16
 (87) Date publication PCT/PCT Publication Date: 2003/10/30
 (85) Entrée phase nationale/National Entry: 2004/10/05
 (86) N° demande PCT/PCT Application No.: US 2003/011554
 (87) N° publication PCT/PCT Publication No.: 2003/089658
 (30) Priorité/Priority: 2002/04/19 (10/126,819) US

(51) Cl.Int.⁷/Int.Cl.⁷ C12Q 1/00, G01N 33/487, G01N 27/30
 (71) Demandeur/Applicant:
NOVA BIOMEDICAL CORPORATION, US
 (72) Inventeurs/Inventors:
CAI, XIAOHUA, US;
WINARTA, HANDANI, US;
VO, ANDY, US;
YOUNG, CHUNG CHANG, US
 (74) Agent: MILTON, GELLER LLP

(54) Titre : CAPTEUR JETABLE AVEC ADMISSION PAR ORIFICE D'ECHANTILLON RENFORCE
 (54) Title: DISPOSABLE SENSOR WITH ENHANCED SAMPLE PORT INLET



(57) **Abrégé/Abstract:**

A disposable biosensor for testing a fluid sample including a laminated strip with a first and second end, a reference electrode embedded in the laminated strip proximate to the first end, at least one working electrode embedded in the laminated strip proximate to the first end and the reference electrode, an open path for receiving a fluid sample beginning from the first end and connecting to a vent spaced from the first end, the open path being sufficiently long to expose the reference electrode and the working electrode to the fluid sample, and conductive contacts located at the second end of the laminated strip. The laminated strip has a base layer with a conductive coating, a reagent holding layer, a channel forming layer and a cover having an inlet notch at the first end. The working electrode contains a reagent having an enzyme.

(12) INTERNATIONAL APPLICATION PUBLISHED UNDER THE PATENT COOPERATION TREATY (PCT)

(19) World Intellectual Property Organization
International Bureau



(43) International Publication Date
30 October 2003 (30.10.2003)

PCT

(10) International Publication Number
WO 03/089658 A1

- (51) International Patent Classification⁷: C12Q 1/00,
G01N 27/30, 33/487
- (21) International Application Number: PCT/US03/11554
- (22) International Filing Date: 16 April 2003 (16.04.2003)
- (25) Filing Language: English
- (26) Publication Language: English
- (30) Priority Data:
10/126,819 19 April 2002 (19.04.2002) US
- (71) Applicant: NOVA BIOMEDICAL CORPORATION
[US/US]; 200 Prospect Street, Waltham, MA 02254-9141
(US).
- (72) Inventors: CAI, Xiaohua; 19 McCulloch Street, Need-
ham, MA 02494 (US). WINARTA, Handani; 18 Hyacinth

Drive, Nashua, NH 03062 (US). VO, Andy; 37A Cen-
tral Street, Somerville, MA 02143 (US). YOUNG, Chung,
Chang; 145 Buckskin Drive, Weston, MA 02193 (US).

- (74) Agent: DELEAULT, Robert, R.; Mesmer & Deleault,
PLLC, 41 Brook Street, Manchester, NH 03104 (US).
- (81) Designated States (*national*): AE, AG, AL, AM, AT, AU,
AZ, BA, BB, BG, BR, BY, BZ, CA, CH, CN, CO, CR, CU,
CZ, DE, DK, DM, DZ, EC, EE, ES, FI, GB, GD, GE, GH,
GM, HR, HU, ID, IL, IN, IS, JP, KE, KG, KP, KR, KZ, LC,
LK, LR, LS, LT, LU, LV, MA, MD, MG, MK, MN, MW,
MX, MZ, NI, NO, NZ, OM, PH, PL, PT, RO, RU, SC, SD,
SE, SG, SK, SL, TJ, TM, TN, TR, TT, TZ, UA, UG, UZ,
VC, VN, YU, ZA, ZM, ZW.
- (84) Designated States (*regional*): ARIPO patent (GH, GM,
KE, LS, MW, MZ, SD, SL, SZ, TZ, UG, ZM, ZW),
Eurasian patent (AM, AZ, BY, KG, KZ, MD, RU, TJ, TM),
European patent (AT, BE, BG, CH, CY, CZ, DE, DK, EE,

[Continued on next page]

(54) Title: DISPOSABLE SENSOR WITH ENHANCED SAMPLE PORT INLET

10

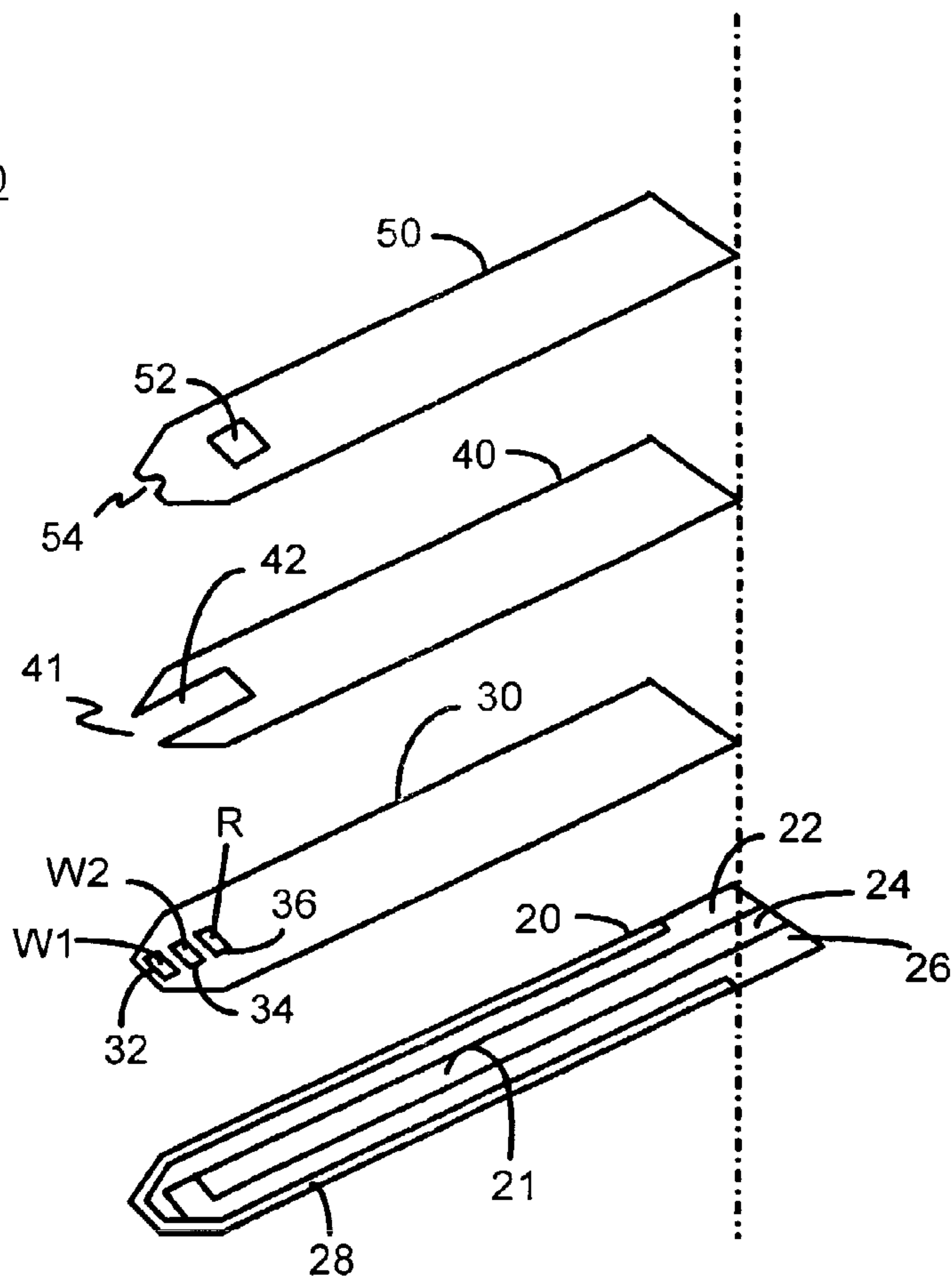

(57) Abstract: A disposable biosensor for testing a fluid sample including a laminated strip with a first and second end, a reference electrode embedded in the laminated strip proximate to the first end, at least one working electrode embedded in the laminated strip proximate to the first end and the reference electrode, an open path for receiving a fluid sample beginning from the first end and connecting to a vent spaced from the first end, the open path being sufficiently long to expose the reference electrode and the working electrode to the fluid sample, and conductive contacts located at the second end of the laminated strip. The laminated strip has a base layer with a conductive coating, a reagent holding layer, a channel forming layer and a cover having an inlet notch at the first end. The working electrode contains a reagent having an enzyme.

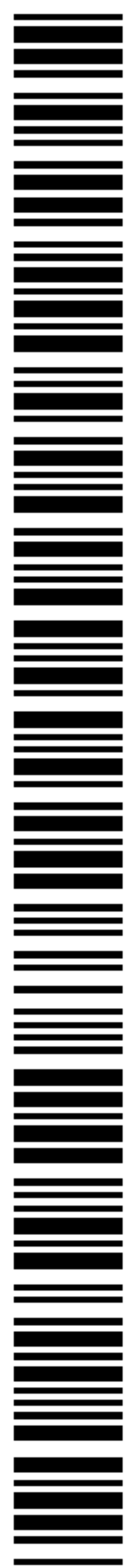

WO 03/089658 A1

WO 03/089658 A1

ES, FI, FR, GB, GR, HU, IE, IT, LU, MC, NL, PT, RO, SE, SI, SK, TR), OAPI patent (BF, BJ, CF, CG, CI, CM, GA, GN, GQ, GW, ML, MR, NE, SN, TD, TG).

patent (AT, BE, BG, CH, CY, CZ, DE, DK, EE, ES, FI, FR, GB, GR, HU, IE, IT, LU, MC, NL, PT, RO, SE, SI, SK, TR), OAPI patent (BF, BJ, CF, CG, CI, CM, GA, GN, GQ, GW, ML, MR, NE, SN, TD, TG)

Declarations under Rule 4.17:

- as to applicant's entitlement to apply for and be granted a patent (Rule 4.17(ii)) for the following designations AE, AG, AL, AM, AT, AU, AZ, BA, BB, BG, BR, BY, BZ, CA, CH, CN, CO, CR, CU, CZ, DE, DK, DM, DZ, EC, EE, ES, FI, GB, GD, GE, GH, GM, HR, HU, ID, IL, IN, IS, JP, KE, KG, KP, KR, KZ, LC, LK, LR, LS, LT, LU, LV, MA, MD, MG, MK, MN, MW, MX, MZ, NI, NO, NZ, OM, PH, PL, PT, RO, RU, SC, SD, SE, SG, SK, SL, TJ, TM, TN, TR, TT, TZ, UA, UG, UZ, VC, VN, YU, ZA, ZM, ZW, ARIPO patent (GH, GM, KE, LS, MW, MZ, SD, SL, SZ, TZ, UG, ZM, ZW), Eurasian patent (AM, AZ, BY, KG, KZ, MD, RU, TJ, TM), European

- as to the applicant's entitlement to claim the priority of the earlier application (Rule 4.17(iii)) for all designations

Published:

- with international search report
- before the expiration of the time limit for amending the claims and to be republished in the event of receipt of amendments

For two-letter codes and other abbreviations, refer to the "Guidance Notes on Codes and Abbreviations" appearing at the beginning of each regular issue of the PCT Gazette.

DISPOSABLE SENSOR WITH ENHANCED SAMPLE PORT INLET

BACKGROUND OF THE INVENTION

5 1. Field of the Invention

The present invention relates generally to electrochemical sensors that can be used for the quantification of a specific component or analyte in a liquid sample. Particularly, this invention relates to a new and improved electrochemical sensor and to a new and improved method of fabricating electrochemical sensors.

10 More particularly, this invention relates to a disposable electrochemical sensor that is inexpensive to manufacture. Even more particularly, this invention relates to a disposable electrochemical sensor that gives accurate readings in the presence of interferents and varying red blood cells (hematocrit). Still even more particularly, this invention relates to disposable electrochemical sensors that are
15 used for performing electrochemical assays for the accurate determination of analytes in physiological fluids.

2. Description of the Prior Art

Biosensors have been known for more than three decades. They are used
20 to determine concentrations of various analytes in fluids. Of particular interest is the measurement of blood glucose. It is well known that the concentration of blood glucose is extremely important for maintaining homeostasis. Products that measure fluctuations in a person's blood sugar, or glucose levels have become
25 everyday necessities for many of the nation's millions of diabetics. Because this disorder can cause dangerous anomalies in blood chemistry and is believed to be a contributor to vision loss and kidney failure, most diabetics need to test themselves periodically and adjust their glucose level accordingly, usually with insulin injections. If the concentration of blood glucose is below the normal range, patients can suffer from unconsciousness and lowered blood pressure, which
30 may even result in death. If the fasting blood glucose concentration is higher than the normal range, it can result in vision loss, kidney failure and vascular disease. Thus, the measurement of blood glucose levels has become a daily necessity for diabetic individuals who control their level of blood glucose by insulin therapy.

Patients who are insulin dependent are instructed by doctors to check their blood-sugar levels as often as four times a day. To accommodate a normal life style to the need of frequent monitoring of glucose levels, home blood glucose testing was made available with the development of reagent strips for whole blood testing.

One type of blood glucose biosensor is an enzyme electrode combined with a mediator compound, which shuttles electrons between the enzyme and the electrode resulting in a measurable current signal when glucose is present. The most commonly used mediators are potassium ferricyanide, ferrocene and its derivatives, as well as other metal-complexes. Many sensors based on this second type of electrode have been disclosed.

However, the prior art devices suffer from various shortcomings. One of these shortcomings is interference with biosensor readings caused by other substances in the sample fluid, which can oxidize at the same potential. Prevalent among these is ascorbic acid, uric acid and acetaminophen. As these and other interfering substances oxidize, the current resulting from their oxidation is added to and indistinguishable from the current resulting from the oxidation of the blood analyte being measured. An error therefore results in the quantification of the blood analyte.

Another shortcoming is the interference caused by red blood cells (the hematocrit effect). This interference tends to cause an artificially high response rate for low hematocrit levels and, conversely, an artificially low response rate for high hematocrit levels.

Additional shortcomings of the prior art devices are that they have a more limited linear range and require a relatively large quantity of sample volume. Further, they require a relatively longer waiting time for development of a steady-state response before a reading can be achieved. Another shortcoming of biosensors having an end or side inlet for direct introduction of the blood sample to the sample chamber from the source of the blood droplet is the inadvertent blockage or partial blockage of the inlet by the blood source. Users tend to push the biosensor hard against the blood sampling point such as at the finger or the arm. Because the entrance to the capillary channel of the biosensor is small,

such action typically blocks or partially blocks the inlet. The result is that (1) the blood does not enter the capillary channel at all, or (2) the blood partially enters the channel but does not fill it up sufficiently, or (3) the blood fills up the capillary channel very slowly. Under scenario (1), the meter may not be triggered and thus not reading is made. Under scenarios (2) and (3), the meter may not be triggered or it may be triggered but gives inaccurate test results due to insufficient sample or the slowness of the capillary filling action.

Each of these shortcomings may, either individually or when combined with one or more of the other shortcomings, contribute to erroneous measurement readings during analysis.

Because of the importance of obtaining accurate glucose readings, it would be highly desirable to develop a reliable and user-friendly electrochemical sensor, which does not have one or more of the drawbacks mentioned above.

Therefore, what is needed is an electrochemical sensor that incorporates an interference-correcting electrode to minimize the interference caused by oxidizable substances present in the sample fluid. What is further needed is an electrochemical sensor whose response is substantially independent of the hematocrit of the sample fluid. What is still further needed is an electrochemical sensor that requires less sample volume than previously required by the prior art.

Yet, what is still further needed is an electrochemical sensor that has a wide linear measurement range; that is, a sensor having a reduced or negligible interference effect and useable over a wider glucose concentration. What is also needed is an electrochemical sensor with a modified inlet port to facilitate introduction of the sample into the sample chamber of the electrochemical sensor.

SUMMARY OF THE INVENTION

It is an object of the present invention to provide an improved electrochemical sensor that combines an enzyme and a mediator. It is a further object of the present invention to provide an electrochemical sensor that incorporates an interference-correcting electrode to minimize the interference caused by oxidizable substances present in the sample fluid. It is a further object

of the present invention to provide an electrochemical sensor whose response is substantially independent of the hematocrit levels of the sample fluid. It is still another object of the present invention to provide an electrochemical sensor that has a wide linear measurement range. It is yet another object of the present invention to provide an electrochemical sensor that has a modified inlet port to facilitate sample introduction.

The present invention achieves these and other objectives by providing an electrochemical sensor that has a modified sample inlet port for facilitating sample introduction and that requires a smaller sample size and compensates for interference from oxidizable species in the sample and from varying hematocrit levels. The present invention has a laminated, elongated body having a sample fluid channel connected between an opening on one end of the laminated body and a vent hole spaced from the opening. Within the fluid channel lie at least one working electrode and a reference electrode. The working electrode and the reference electrode are each in electrical contact with separate conductive conduits. The separate conductive conduits terminate and are exposed for making an electrical connection to a reading device on the end opposite the open channel end of the laminated body.

The laminated body has a base insulating layer made from a plastic material. Several conductive conduits are delineated on the base insulating layer. The conductive conduits may be deposited on the insulating layer by screen printing, by vapor deposition, or by any method that provides for a conductive layer, which adheres to the base insulating layer. The conductive conduits may be individually disposed on the insulating layer, or a conductive layer may be disposed on the insulating layer followed by etching/scribing the required number of conductive conduits. The etching process may be accomplished chemically, by mechanically scribing lines in the conductive layer, by using a laser to scribe the conductive layer into separate conductive conduits, or by any means that will cause a break between and among the separate conductive conduits required by the present invention. The preferred conductive coatings are gold film or a tin oxide/gold film composition. It should be pointed out that although the same electrically conducting substance (gold film or tin oxide/gold film) after scoring is

used as conducting material for both working electrodes and the reference electrode, this material itself cannot function as a reference electrode. To make the reference electrode work, there must be a redox reaction (e.g., $\text{Fe}(\text{CN})_6^{3-} + e^- \rightleftharpoons \text{Fe}(\text{CN})_6^{4-}$) at the electrically conducting material when a potential is applied.

5 Therefore, a redox couple or mediator must be present at the conducting material used for the reference electrode.

On top of the base insulating layer and the conductive conduits, the laminated body has a first middle insulating layer or a reagent holding layer containing cutouts for at least one working electrode and a reference electrode. If
10 a second working electrode is included, it and the reference electrode may share the same cutout. Where three cutouts are used, each cutout corresponds to and exposes a small portion of a single conductive conduit. The cutouts for the working electrodes can be the same or different size. The cutout for the reference electrode may be the same or different size as the cutouts for the
15 working electrodes. The placement of all of the cutouts is such that they will all co-exist within the sample fluid channel described above. This reagent holding layer is also made of an insulating dielectric material, preferably plastic, and may be made by die cutting the material mechanically or with a laser and then fastening the material to the base layer. An adhesive, such as a pressure-
20 sensitive adhesive, may be used to secure the reagent holding layer to the base layer. Adhesion may also be accomplished by ultrasonically bonding the reagent holding layer to the base layer. The reagent holding layer may also be made by screen printing the first middle insulating layer over the base layer.

The thickness of the reagent holding layer must be of sufficient thickness
25 for loading a sufficient amount of electrode material for use as an electrochemical sensor. Each cutout contains electrode material. The electrode material has a redox mediator with at least one of a stabilizer, a binder, a surfactant, and a buffer. At least one of the cutouts also contains an enzyme capable of catalyzing a reaction involving a substrate for the enzyme. The redox mediator is capable of
30 transferring electrons between the enzyme-catalyzed reaction and the working electrode.

The laminated body also has a second middle insulating layer, or channel forming layer, on top of the reagent holding layer. The second middle layer is also made of a plastic insulating material and creates the sample fluid channel of the laminated body. It contains a U-shaped cutout on one end which overlays the cutouts in the reagent holding layer with the open end corresponding to the open end of the laminated body described earlier.

The laminated body of the present invention has a top layer with a vent opening and an inlet notch. The vent opening is located such that at least a portion of the vent opening overlays the bottom of the U-shaped cutout of the channel forming layer. The vent allows air within the sample fluid channel to escape as the sample fluid enters the open end of the laminated body. The inlet notch facilitates sample introduction through the inlet by creating a top inlet aperture, which is in communication with the end inlet of the sensor. In the event that the sample inlet port is inadvertently blocked by the source of the blood sample such as a finger, the inlet notch remains open for receiving the sample fluid.

The sample fluid generally fills the sample fluid channel by capillary action. In small volume situations, the extent of capillary action is dependent on the hydrophobic/hydrophilic nature of the surfaces in contact with the fluid undergoing capillary action. This is also known as the wettability of the material. Capillary forces are enhanced by either using a hydrophilic insulating material to form the top layer, or by coating at least a portion of one side of a hydrophobic insulating material with a hydrophilic substance in the area of the top layer that faces the sample fluid channel between the open end of the laminated body and the vent opening of the top layer. It should be understood that an entire side of the top layer may be coated with the hydrophilic substance and then bonded to the second middle layer.

The number of cutouts in the reagent holding layer can be one, two and three or more. To use only one cutout, the single cutout must expose portions of at least two conductive conduits. Such an arrangement allows for testing a smaller sample volume compared to a two or a three cutout embodiment.

However, this embodiment lacks the interference correction features of the other embodiments.

An embodiment having two cutouts is an alternative to the single cutout version. It has one cutout serving as the working electrode and the other one
5 serving as a reference electrode. Another embodiment of the two cutout version combines the features of making the single cutout with that of the two cutout version. One of the cutouts containing electrode material is scored into two parts, one part serving as a first working electrode and the second part serving as the reference electrode. The second cutout serves as a second working electrode.
10 Such a design is an alternative embodiment of the preferred embodiment of the present invention. This version of the two-cutout embodiment has the interference and hematocrit correction features but also allows for measuring an even smaller sample volume than that of the three-cutout embodiment.

In the three-cutout embodiment, two cutouts contain material for the
15 working electrodes (W1 and W2) and one for the reference electrode (R). W2 further contains the enzyme capable of catalyzing a substrate of the enzyme. The three electrodes are positioned and sized in such a way that the resistance of the fluid sample can be precisely measured and the possible carry-over from W2 is minimized. The possible electrode arrangements within the sample fluid
20 channel may be W1-W2-R, W1-R-W2, R-W1-W2, W2-W1-R, W2-R-W1, or R-W2-W1 with the arrangement listed as the arrangement of electrodes would appear from the open end of the laminated body to the vent opening. The preferred position was found to be W1-W2-R; that is, as the sample fluid entered the open end of the laminated body, the fluid would cover W1 first, then W2, then
25 R. The preferred position allows for the precise measurement of blood sample resistance. This is necessary for good correlation between the resistance and hematocrit level in the blood sample. The preferred position also obviates reliability and accuracy problems due to an insufficient sample fluid size. The meter will not be triggered until the sample reaches the R. Such an arrangement
30 also obviates possible carryover problems from enzyme-loaded working electrode (W2) to non-enzyme-loaded working electrode (W1).

As mentioned earlier, oxidizable interferents such as ascorbic acid, uric acid and acetaminophen, to name a few, cause inaccurate readings in the output of an electrochemical biosensor. The present invention negates this effect by subtracting the current response at W1 (first working electrode) from the current response from W2 (second working electrode) to calculate the analyte concentration in the sample fluid. This is achieved by maintaining the surface area of W1 substantially equal to the surface area of W2. Also important is the composition of the reagents disposed on W1 and W2. The reagents are designed to have a minimal effect on the response of the interferences which also contributes to the accuracy of the analyte measurement.

The hematocrit interference is reduced by using a two-step process. First, the resistance (r-value) between any two electrodes is measured. The r-value is then used to estimate the hematocrit level in the sample fluid. The following equation represents this relationship:

$$r = k_1 / (1-H) \quad \text{Eq. (1)}$$

where
 r is resistance value measured in Ohms or Kilo-Ohms
 H is hematocrit level
 k₁ is a constant

Second, the hematocrit level value is then used to mathematically correct the enzyme concentration reading obtained from above. The following equation represents the calculation performed using the calculated hematocrit level from Eq. (1):

$$C_{\text{corr}} = C_{\text{mea}} / (k_2 + k_3 C_{\text{mea}} + (k_4 + k_5 C_{\text{mea}})(1-H)) \quad \text{Eq. (2)}$$

where
 C_{corr} is the corrected analyte concentration
 C_{mea} is the measured analyte concentration
 k₂-k₅ are constants

H is the calculated hematocrit level from Eq. (1)

Constants k_1 - k_5 are derived from empirical data.

All of the advantages of the present invention will be made clearer upon
5 review of the detailed description, drawings and appended claims.

BRIEF DESCRIPTION OF THE DRAWINGS

FIGURE 1 is a perspective view of the present invention showing the open end,
the vent and the electrical contact points of the laminated body.

10

FIGURE 2 is an exploded, perspective view of the present invention showing the
various layers of the laminated body.

FIGURES 3A, 3B, 3C, and 3D are top views of a strip of each layer of the present
15 invention showing the patterns for making multiple sensors of the present
invention.

FIGURE 3E is a top view of a segment of the laminated strip of the present
invention showing the patterns for making multiple sensors of the present
20 invention.

DETAILED DESCRIPTION OF THE PREFERRED EMBODIMENT

The preferred embodiment of the present invention is illustrated in
FIGURES 1-3. Figure 1 shows a sensor **10** of the present invention. Sensor **10**
25 has a laminated body **100**, a fluid sampling end **110**, an electrical contact end
120, and a vent opening **52**. Fluid sampling end **110** includes a sample fluid
channel **112** between a sampling end aperture **114** and vent opening **52**.
Sampling end **110** also includes an inlet notch **54**. Electrical contact end **120** has
at least three discrete conductive contacts **122**, **124** and **126**.

30 Referring now to Figure 2, laminated body **100** is composed of a base
insulating layer **20**, a first middle layer or reagent holding layer **30**, a second
middle layer or channel forming layer **40**, and a top layer **50**. All layers are made

of a dielectric material, preferably plastic. Examples of a preferred dielectric material are polyvinyl chloride, polycarbonate, polysulfone, nylon, polyurethane, cellulose nitrate, cellulose propionate, cellulose acetate, cellulose acetate butyrate, polyester, acrylic and polystyrene. Base insulating layer **20** has a
5 conductive layer **21** on which is delineated a first conductive conduit **22**, a second conductive conduit **24** and a third conductive conduit **26**. Conductive conduits **22**, **24** and **26** may be formed by scribing or scoring the conductive layer **21** as illustrated in Fig. 2 or by silk-screening the conductive conduits **22**, **24** and **26** onto base layer **20**. Scribing or scoring of conductive layer **21** may be done by
10 mechanically scribing the conductive layer **21** sufficiently to create the three independent conductive conduits **22**, **24** and **26**. The preferred scribing or scoring method of the present invention is done by using a carbon dioxide (CO₂) laser, a YAG laser or an excimer laser. An additional scoring line **28** (enlarged and not to scale; for illustrative purposes only) may be made, but is not necessary to the
15 functionality of sensor **10**, along the outer edge of base layer **20** in order to avoid potential static problems which could give rise to a noisy signal. Conductive layer **21** may be made of any electrically conductive material, preferably gold or tin oxide/gold. A useable material for base layer **20** is a tin oxide/gold polyester film (Cat. No. FM-1) or a gold polyester film (Cat. No. FM-2) sold by Courtaulds
20 Performance Films, Canoga Park, California.

First middle layer **30** has a first electrode cutout **32** which exposes a portion of first conductive conduit **22**, a second electrode cutout **34** which exposes a portion of second conductive conduit **24** and a third electrode cutout **36** which exposes a portion of third conductive conduit **26**. First layer **30** is made of a
25 plastic material, preferably a medical grade one-sided tape available from Adhesive Research, Inc., of Glen Rock, Pennsylvania. Acceptable thickness of the tape for use in the present invention are in the range of about 0.002 in. (0.051 mm) to about 0.005 in. (0.127 mm). One such tape, Arcare[®] 7815, is preferred because of its ease of handling and shows good performance in terms of its
30 ability to hold a sufficient quantity of chemical reagents and to promote a favorable blood flow speed (capillary action) through sample fluid channel **112** of

sensor **10**. It should be understood that the use of a tape is not required. A plastic insulating layer may be coated with a pressure sensitive adhesive, or may be ultrasonically-bonded to base layer **20**, or may be silk-screened onto base layer **20** to achieve the same results as using the polyester tape mentioned.

5 The three cutouts **32**, **34** and **36** define electrode areas **W1**, **W2** and **R**, respectively, and hold chemical reagents forming two working electrodes and one reference electrode. Typically, electrode area **R** must be loaded with a redox reagent or mediator to make the reference electrode function. If **R** is not loaded with a redox reagent or mediator, working electrodes **W1** and **W2** will not work
10 properly. The reagents preferably contain an oxidized form of a redox mediator, a stabilizer, a binder, a surfactant, and a buffer. Typically, the redox mediator may be at least one of ferrocene, potassium ferricyanide and other ferrocene derivatives. The preferred stabilizer is polyethylene glycol, the preferred binder is methyl cellulose, the preferred surfactant is t-octylphenoxypolyethoxyethanol, and
15 the preferred buffer is a citrate buffer. Electrode area **W2** is preferably loaded with the same chemical reagents loaded into electrode areas **W1** and **R** but with the addition of an enzyme capable of catalyzing a reaction involving a substrate for the enzyme or a substrate catalytically reactive with an enzyme and a mediator capable of transferring electrons transferred between the enzyme-
20 catalyzed reaction and the working electrode to create a current representative of the activity of the enzyme or substrate and representative of the compound. It should be pointed out that **R** can also be loaded with the same chemistry as **W2**. The enzyme could be glucose oxidase, lactate oxidase, cholesterol oxidase and creatinine amidohydrolase

25 The cutouts and electrode areas of first layer **30** are positioned relative to each other and to the flow of the sample fluid in sample fluid channel **112** such that the resistance of the sample fluid may be precisely measured and the possible carryover from electrode area **W2** to electrode area **W1** could be minimized. Using fluid sample end **110** of sensor **10** as a reference point, the
30 arrangements of the electrode areas could be **W1-W2-R**, **W1-R-W2** or **R-W1-W2**. The preferred position was found to be **W1-W2-R**.

Second middle layer **40** has a U-shaped channel cutout **42** located at second layer sensor end **41**. The length of channel cutout **42** is such that when second middle layer **40** is layered on top of first middle layer **30**, electrode areas **W1**, **W2** and **R** are within the space defined by channel cutout **42**. The thickness of second middle layer **40** was found to be critical for the volume of the capillary channel and for the speed of the sample fluid flow into sample fluid channel **112**, which is filled by capillary action of the sample fluid.

Top layer **50**, which is placed over second middle layer **40**, has a vent opening **52** spaced from fluid sample end **110** of sensor **10** to insure that sample fluid in fluid channel **112** will completely cover electrode areas **W1**, **W2** and **R**. Vent opening **52** is placed in top layer **50** so that at least a portion of vent opening **52** exposes a portion of bottom of channel cutout **42** of second middle layer **40**. Preferably, vent opening **52** will expose a portion of and partially overlay a portion of the U-shaped cutout **42** of second middle layer **40** that is furthest from fluid sampling end **110** of sensor **10**.

Top layer **50** also includes an inlet notch **54** at fluid sample end **110** of sensor **10**. Inlet notch **54** is included to facilitate sample loading in fluid channel **112** where sampling end aperture **114** could be inadvertently blocked if sample notch **54** were absent. Sample notch **54** may have any shape and is not limited to the semi-circular shape shown.

Preparation of Reagents 1 & 2

Reagents 1 and 2 comprise the oxidized form of a redox mediator, a stabilizer, a binder, a surfactant, and a buffer. Reagent 2, in addition, contains an enzyme. The oxidized form of the redox mediator, potassium ferricyanide, was found to be stable in the matrices. The quantity used in the formulation must be sufficient to attain a workable linear range. The enzyme must also have sufficient activity, purity and stability. A commercially available glucose oxidase may be obtained from Biozyme, San Diego, California as Cat. No. G03A, about 270U/mg. The stabilizer must be sufficiently water-soluble and be capable of stabilizing both the mediator and the enzyme. The binder should also be capable of binding

all other chemicals in the reagents in electrode areas **W1**, **W2** and **R** to the
conductive surface/layer **21** of base layer **20**. The preferred stabilizer is
polyethylene glycol (Cat. No. P4338, Sigma Chemicals, St. Louis, MO). The
preferred binder is Methocel 60 HG (Cat. No. 64655, Fluka Chemical, Milwaukee,
5 WI). The buffer solution must have sufficient buffer capacity and pH value to
optimize the enzyme reaction. A 0.05M citrate buffer is preferred. The surfactant
is necessary to facilitate dispensing of Reagents 1 and 2 into cutouts **32**, **34** and
36 of middle layer **30** as well as for quickly dissolving the dry chemical reagents.
The amount and type of surfactant is selected to assure the previously mentioned
10 functions and to avoid a denaturing effect on the enzyme. The preferred
surfactant is Triton X-100. The reagents are prepared as follows:

Reagent 1

Step 1: Prepare 50 mM citrate buffer (pH 5.7) by dissolving 0.1512 grams citric
15 acid and 1.2580 grams sodium citrate in 100 ml of deionized water.

Step 2: Prepare a 1% methocel 60HG solution by stirring 1 gram of methocel in
100 ml of citrate buffer from Step 1 for 12 hours.

Step 3: Add 0.3 ml of 10% Triton X -100 into the methocel solution.

Step 4: Add 2.5 grams of polyethylene glycol into the solution from Step 3.

20 Step 5: While stirring, add 1 gram of potassium ferricyanide to the solution from
Step 4.

Reagent 2

Step 1-Step 4: same steps as Reagent 1.

25 Step 5: While stirring, add 6.5 grams potassium ferricyanide to the solution of
Step 4.

Step 6: Add 1.0 gram of glucose oxidase to the solution of Step 5 and stir for 10
minutes or until all solid materials are completely dissolved.

Electrode Construction

30 A piece of a gold or tin oxide/gold polyester film available from Courtaulds
Performance Films is cut to shape, as illustrated in Fig. 2, forming base layer **20**

of sensor **10**. A CO₂ laser is used to score the gold or tin oxide/gold polyester film. As illustrated in Fig. 2, the film is scored by the laser such that three electrodes at sample fluid end **110** and three contact points **122**, **124** and **126** are formed at electrical contact end **120**. The scoring line is very thin but sufficient to
5 create three separate electrical conductors. A scoring line **28** can be made, but is not necessary, along the outer edge of base layer **20** to avoid potential static problems which could cause a noisy signal from the finished sensor **10**.

A piece of one-sided adhesive tape is then cut to size and shape forming first middle layer **30** so that it will cover a majority of the conductive layer **21** of
10 base layer **20** except for exposing a small electrical contact area illustrated in Fig. 1. Three rectangular, square or circular cutouts **32**, **34** and **36** of substantially equal size are punched by CO₂ laser (25W laser available from Synrad, Inc., San Diego, CA). Cutouts **32**, **34** and **36** define the electrode areas **W1**, **W2** and **R**, which hold chemical reagents. The size of the cutouts is preferred to be made as
15 small as possible in order to make the fluid sample channel **112** of sensor **10** as short as possible while still being capable of holding sufficient chemical reagent for the electrodes to function properly. The preferred hole size for the present invention has a typical dimension of about 0.033 in. (0.84 mm) by about 0.043 in. (1.09 mm). As illustrated in Fig. 2, cutouts **32**, **34** and **36** are aligned with each
20 other and having a spacing of about 0.028 in. (0.71 mm) between them. The rectangular cutouts are for illustrative purposes only. It should be understood that the shape of the cutouts is not critical provided that the size of the cutouts is big enough to hold sufficient chemical reagents for the electrodes to function properly but small enough to allow for a reasonably small sample channel. As noted
25 earlier, changing the shape of the cutouts or the surface area of the cutouts may require changing the constant values k_1 - k_5 for Eq. 1 and Eq. 2. As stated previously, the preferred arrangement of the electrodes formed in cutouts **32**, **34** and **36** is **W1** (working electrode 1), **W2** (working electrode 2) and **R** (reference electrode).

30 0.4 microliters of Reagent 1 is dispensed into each electrode area **W1** and **R**. Reagent 1 is a mixture of a redox mediator, a stabilizer, a binder, a surfactant, and a buffer. The preferred mixture for Reagent 1 is made by mixing the following

components in the described percentages: about 1wt% potassium ferricyanide, about 2.5wt% polyethylene glycol, about 1wt% methocel 60 HG, about 0.03wt% Triton X-100 and about 0.05M citrate buffer (pH 5.7). 0.4 microliters of Reagent 2 is dispensed into electrode area **W2**.

5 Reagent 2 is a mixture similar to that of Reagent 1 but with the addition of an enzyme capable of catalyzing a reaction involving a substrate of the enzyme. The preferred enzyme is glucose oxidase. The preferred mixture for Reagent 2 is made by mixing the following percentages of the following ingredients: about
10 6.5wt% potassium ferricyanide, about 2.5wt% polyethylene glycol, about 1wt% methocel 60 HG, about 0.03wt% Triton X-100, about 0.05M citrate buffer (pH 5.7), and about 1wt% glucose oxidase. After the addition of the reagents, the device was dried for about 2 minutes at 55°C in an oven. After drying, a piece of double-sided tape available from Adhesive Research was fashioned into second middle layer **40** with U-shaped channel **42**. Second middle layer **40** is then
15 layered onto first middle layer **30**. As mentioned earlier, this second middle layer **40** serves as a spacer and defines the size of the fluid sample channel **112**. Its width and length is optimized to provide for a relatively quick moving fluid sample. The preferred size of U-shaped channel **42** is about 0.063 in. (1.60 mm) wide by about 0.248 in. (6.30 mm) long.

20 A piece of a transparency film (Cat. No. PP2200 or PP2500 available from 3M) is fashioned into top layer **50**. A rectangular vent hole **52** and a semi-circular notch **54** are made using the CO₂ laser previously mentioned. The preferred size of vent hole **52** is about 0.075 in. (1.91 mm) by about 0.059 in. (1.50 mm). Vent hole **52** is located approximately 0.130 in. (3.3 mm) from fluid end **110** of sensor
25 **10**. Semi-circular notch **54** has a radius of approximately 0.030 in. (0.75 mm) and is recessed from fluid end **110** of sensor **10**. Top layer **50** is aligned and layered onto second middle layer **40** to complete the assembly of sensor **10**, as illustrated in Fig. 1.

30 Although the description of electrode construction above describes construction for a single sensor, the design and materials used are ideal for making multiple sensors from one piece, or a continuous strip, of each layer material as shown in Fig. 3A-3E. This would be accomplished by starting with a

relative large piece of base layer **20** having conducting layer **21** thereon. A plurality of scored lines are made into conductive layer **21** such that a repetitive pattern, as illustrated in Fig. 3A, is created using the preferred scribing method described previously whereby each pattern will eventually define the three

5 conductive paths **22**, **24** and **26** for each sensor. Similarly, a large piece of first middle layer **30**, which is illustrated in Fig. 3B and which also has a plurality of cutouts **32**, **34**, and **36** in a repetitive pattern, is sized to fit over base layer **20** in such a way that a plurality of sensors **10** will be had when completed. The size of each cutout and the electrode material disposed in the plurality of electrode areas

10 **W1**, **R** and **W2** are similar to that disclosed above. After disposing Reagents 1 & 2 in their respective cutouts and dried, a large piece of second middle layer **40** having a plurality of elongated cutouts **42** and illustrated in Fig. 3C is layered onto first middle layer **30** such that each elongated cutout **42** of second middle layer **40** contains corresponding cutouts **32**, **34** and **36** of first middle layer **30**. A

15 comparably-sized top layer **50** having a plurality of vent openings **52** and notch forming openings **54'** in a repetitive pattern, as shown in Fig. 3D, is layered onto second middle layer **40**. Fig. 3E is a top view of the combined layers. The laminated strip created by the four layers **20**, **30**, **40** and **50** has a plurality of sensors **10** that can be cut from the laminated strip. The laminated strip is cut

20 longitudinally along line A-A' at fluid sampling end **210** to form a plurality of sampling apertures **114** with sample notches **54** and longitudinally along line B-B' at electrical contact end **220** to form a plurality of conductive contacts **122**, **124** and **126**. The laminated strip is also cut at predetermined intervals along line C-C' forming a plurality of individual sensors **10**. Shaping of the fluid sampling end

25 **120** of each sensor **10**, as illustrated in Fig. 1, may be performed if desired. It should be understood by those skilled in the art that the order in which the laminated strip can be cut is not important. For instance, the laminated strip may be cut at the predetermined intervals (C-C') and then the cuts along A-A' and B-B' can be made to complete the process.

30 A more inclusive description of the compensation characteristics of the present invention along with additional test parameters and examples is provided

in US Patent No. 6,287,451, which is incorporated herein by reference in its entirety.

Although the preferred embodiments of the present invention have been described herein, the above description is merely illustrative. Further modification
5 of the invention herein disclosed will occur to those skilled in the respective arts and all such modifications are deemed to be within the scope of the invention as defined by the appended claims.

What is claimed is:

1. A disposable biosensor comprising:

5 a laminated strip having a first strip end, a second strip end and a vent opening spaced from said first strip end, said laminated strip comprising a base layer with a conductive coating disposed thereon, said base layer having at least two electrodes delineated thereon, a reagent holding layer carried on said base layer, said reagent holding layer having at least two cutouts, a channel forming layer carried on said reagent holding layer, and a cover having a notch at said first strip end;
10 an enclosed channel between said first strip end and said vent opening, said enclosed channel containing said at least two cutouts;
a reagent disposed in said at least two cutouts forming a first working electrode and a reference electrode, said reagent containing an enzyme; and
15 conductive contacts at said second strip end and insulated from said enclosed channel.

2. The biosensor of Claim 1 wherein said enzyme is selected from the group consisting of glucose oxidase, lactate oxidase, cholesterol oxidase, and
20 creatinine amidohydrolase.

3. The biosensor of Claim 1 wherein said reagent holding layer has a third cutout having said reagent disposed therein and forming a second working electrode.
25

4. The biosensor of Claim 1 wherein said reagent further contains at least one of a redox mediator, a stabilizer, a binder, a surfactant, and a buffer.

5. The biosensor of Claim 4 wherein said stabilizer is a polyalkylene glycol, said binder is a cellulose material, and said surfactant is a polyoxyethylene
30 ether.

6. The biosensor of Claim 5 wherein said stabilizer is polyethylene glycol, said binder is methyl cellulose, said surfactant is t-octylphenoxypolyethoxyethanol, and said buffer is a citrate buffer.
- 5 7. The biosensor of Claim 6 wherein said reagent is made from a mixture having starting components comprising about 1wt% to about 6.5wt% of said redox mediator, about 2.5wt% of said stabilizer, about 1wt% of said binder, and about .03wt% of said surfactant in said buffer.
- 10 8. The biosensor of Claim 7 wherein said citrate buffer is about 0.05M.
9. The biosensor of Claim 4 wherein said redox mediator is at least one of potassium ferricyanide and other inorganic and organic redox mediators.
- 15 10. The biosensor of Claim 1 wherein said conductive coating is gold or a gold and tin oxide mix.
11. The biosensor of Claim 1 wherein said base layer, said reagent holding layer, said channel forming layer, and said cover are made of a plastic dielectric material.
- 20
12. The biosensor of Claim 1 wherein said channel forming layer has a thickness sufficient to optimize the flow of said fluid sample along said open path.
- 25
13. The biosensor of Claim 7 wherein said reagent forming said reference electrode is made of a mixture having starting components comprising about 1wt% of said potassium ferricyanide, about 2.5wt% of said polyethylene glycol, about 1wt% of said methyl cellulose, about .03wt% of said t-octylphenoxypolyethoxyethanol, and said citrate buffer is about 0.05M.
- 30

14. The biosensor of Claim 9 wherein said reagent of said first working electrode is made of a mixture having starting components comprising about 6.5wt% of said potassium ferricyanide, about 2.5wt% of said polyethylene glycol, about 1wt% of said methyl cellulose, about .03wt% of said t-
5 octylphenoxypolyethoxyethanol, and said pH buffer is about a 0.05M citrate buffer, and about 1wt% of said enzyme.
15. The biosensor of Claim 14 wherein said enzyme is glucose oxidase.
- 10 16. The biosensor of Claim 3 wherein the surface area of said first working electrode is substantially same as the surface area of said second working electrode.
- 15 17. The biosensor of Claim 3 wherein said reagent forming said second working electrode is substantially similar to said reagent forming said reference electrode.
18. A disposable electrode strip for detecting or measuring the concentration of at least one analyte in a fluid sample, said electrode strip comprising:
20 an insulating base layer having a first base end and a second base end;
a conductive layer disposed on one side of said base layer delineating at least three electrically-distinct conductive paths insulated from each other;
a reagent holding layer sized smaller than said base layer and overlaying
25 a substantial portion of said conductive layer, said reagent holding layer having at least a first cutout portion and a second cutout portion spaced from said first base end, said first cutout portion exposing a limited area of a first of said at least three conductive paths and said second cutout portion exposing a limited area of a second and a third
30 of said at least three conductive paths;
at least two electrode materials wherein a first electrode material is a reagent for measuring the concentration of said at least one analyte

and wherein a second electrode material is a material suitable for use as a reference material, each of said at least two electrode materials contains at least a polyalkylene glycol as a stabilizer, said first material being disposed in said first cutout portion and said second material being disposed in said second cutout portion;

a channel forming layer sized to fit over and coextensive with said reagent holding layer, said channel forming layer having an opening configured to expose an area of said reagent holding layer a limited distance from said first base end, said area including said at least two cutout portions of said reagent holding layer; and

a top layer sized to fit over and coextensive with said channel forming layer creating a sample fluid channel, said top layer having an inlet notch at a first top layer end, said first top layer end being coextensive with said first base end, and a top layer vent spaced from said first base end and configured to expose at least a small portion of said opening of said channel forming layer.

19. The strip of Claim 18 wherein said sample fluid channel is hydrophilic.

20. The device of Claim 18 wherein said first material and said second material further include a redox mediator, a binder, a surfactant, and a buffer.

21. The strip of Claim 20 wherein said redox mediator is at least one metal complex selected from the group consisting of ferrocene, ferrocene derivatives and potassium ferricyanide, said binder is a cellulose material, said surfactant is a polyoxyethylene ether, and said buffer has a pH of about 5 to about 6.

22. The strip of Claim 21 wherein said mediator is potassium ferricyanide, said stabilizer is polyethylene glycol, said binder is methyl cellulose, said

surfactant is t-octylphenoxypolyethoxyethanol, and said buffer is a citrate buffer.

23. The strip of Claim 22 wherein said first electrode material is made of a mixture having starting components comprising about 1wt% of said potassium ferricyanide, about 2.5wt% of said polyethylene glycol, about 1wt% of said methyl cellulose, and about 0.03wt% of said t-octylphenoxypolyethoxyethanol in said citrate buffer.
24. The strip of Claim 22 wherein said second electrode material is made of a mixture having starting components comprising about 6.5wt% of said potassium ferricyanide, about 2.5wt% of said polyethylene glycol, about 1wt% of said methyl cellulose, about 0.03wt% of said t-octylphenoxypolyethoxyethanol, and about 1wt% of an enzyme in said citrate buffer.
25. The strip of Claim 24 wherein said enzyme is glucose oxidase.
26. A method of making a disposable biosensor comprising:
scribing a conductive coating disposed on one side of an elongated base layer having an electrode end and an electrical contact end forming at least two elongated electrical conduits along the length of said base layer wherein a first conduit of said at least two electrical conduits has an L-shape wherein the L-shaped portion of said first conduit is adjacent said second conduit wherein said L-shaped end of said first conduit and a portion of said second conduit are located near said electrode end;
adhering a reagent holding layer over said base layer that is shorter than the length of said base layer such that a portion of each of said at least two elongated conduits is exposed at said electrical contact end, said reagent holding layer having at least two reagent holding cutouts spaced from said electrode end wherein a first cutout exposes a portion

of said first conduit and a second cutout exposes a portion of said second conduit;

adding a reagent mixture to said first cutout forming a reference electrode and said second cutout forming a first working electrode, said reagent mixture in at least said first working electrode having an enzyme

5

capable of catalyzing a reaction involving a substrate for the enzyme;

drying said reagent mixture forming a reagent matrix;

disposing a channel forming layer over said reagent holding layer, said channel forming layer having a U-shaped end portion defining a central elongated channel sized to expose said at least two reagent cutouts of said reagent holding layer; and

10

disposing a top layer over said channel forming layer, said top layer having a vent opening spaced from said electrode end and a notch at said electrode end, said top layer forming an inlet and a capillary space with said U-shaped end portion wherein said vent exposes a portion of said central channel at the end of said capillary space opposite said inlet and said notch exposes a portion of said central channel at said inlet.

15

27. The method of Claim 26 further comprising mixing a redox mediator, a stabilizer, a binder, a surfactant and a buffer forming said reagent mixture.

20

28. A method of making multiple, disposable sensors wherein each sensor has at least a first working electrode and a reference electrode, wherein said first working electrode contains an enzyme capable of catalyzing a reaction involving a substrate for the enzyme, said at least a first working electrode and said reference electrode being disposed in a fluid sample channel for measuring a fluid sample, said method comprising:

25

obtaining a base strip of an insulating material having a layer of conductive material disposed thereon, said base strip having a first edge and a second edge;

scribing in said conductive material a plurality of lines in a repetitive pattern wherein said plurality of lines contain a repetitive pattern forming three conductive paths in each of said repetitive pattern;

disposing a first middle layer of insulating material over said base strip,

5 said first middle layer having a repetitive pattern of at least two cutouts wherein each cutout of each of said repetitive pattern exposes at least an electrode portion of said conductive layer wherein said repetitive pattern of said at least two cutouts are spaced from said first edge of said base strip, and wherein said first middle layer is sized to expose a

10 contact portion of each of said three conductive paths of each repetitive pattern for a distance from said second edge of said base strip;

disposing a first reagent material on one of said at least two cutouts of each repetitive pattern and a second reagent material on the other of said at least two cutouts of each repetitive pattern;

15 drying said first reagent material and said second reagent material;

overlaying a second middle insulating layer over and coextensive with said first middle layer, said second middle layer having a plurality of elongated cutout portions in a repetitive pattern wherein each of said elongated cutout portions exposes a corresponding repetitive pattern of

20 said at least two cutouts of said first middle layer;

disposing a top layer of insulating material over and coextensive with said second middle layer, said top layer having a plurality of vent openings and notch forming holes in a repetitive pattern wherein each of said vent openings exposes a portion of a corresponding repetitive pattern of

25 said elongated cutout portion furthest from said first edge of said base strip and wherein each of said notch forming holes exposes a portion of said corresponding repetitive pattern of said elongated cutout portion closest to said first edge of said base strip, said base strip, said first middle layer, said second middle layer, and said top layer forming a

30 laminated strip;

cutting along and parallel to said first edge of said laminated strip a predetermined distance creating a sample inlet port in each of said

elongated cutout and an inlet notch in said top layer for each of said repetitive pattern;

cutting along and parallel to said second edge of said laminated strip a predetermined distance creating three separate contacts for each of said repetitive pattern; and

separating each of said repetitive pattern forming one of each of said disposable sensors.

29. The method of Claim 28 further comprising drying said first reagent material and said second reagent material at a temperature and for a length of time sufficient to allow said first reagent material and said second reagent material to solidify and adhere to each of said electrode portion of each of said repetitive pattern of said three conductive paths.

30. The method of Claim 28 further comprising mixing a redox mediator, a stabilizer, a binder, a surfactant and a buffer forming said first reagent material, and mixing a redox mediator, a stabilizer, a binder, a surfactant, a buffer, and an enzyme forming said second reagent material.

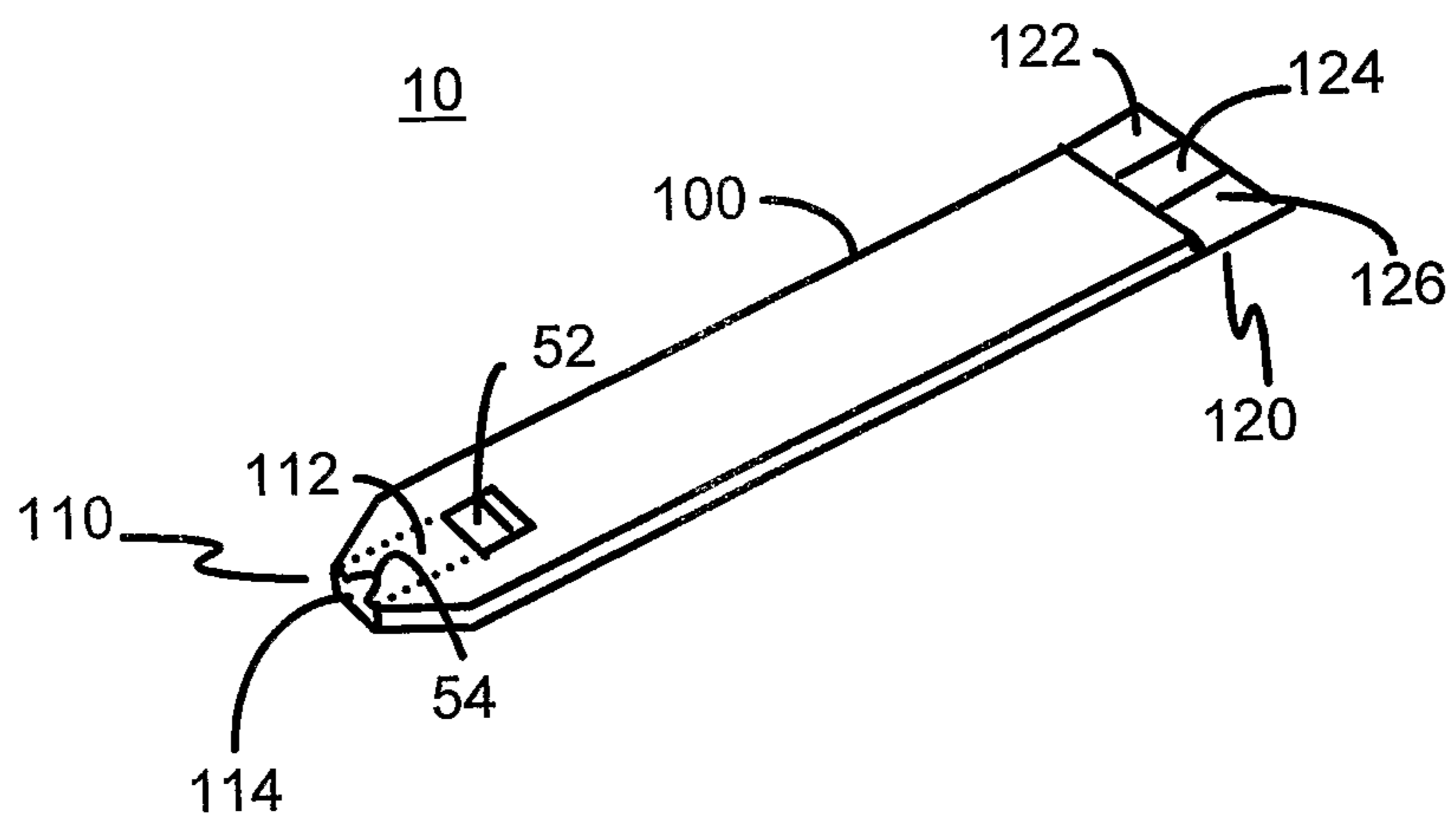

Fig. 1

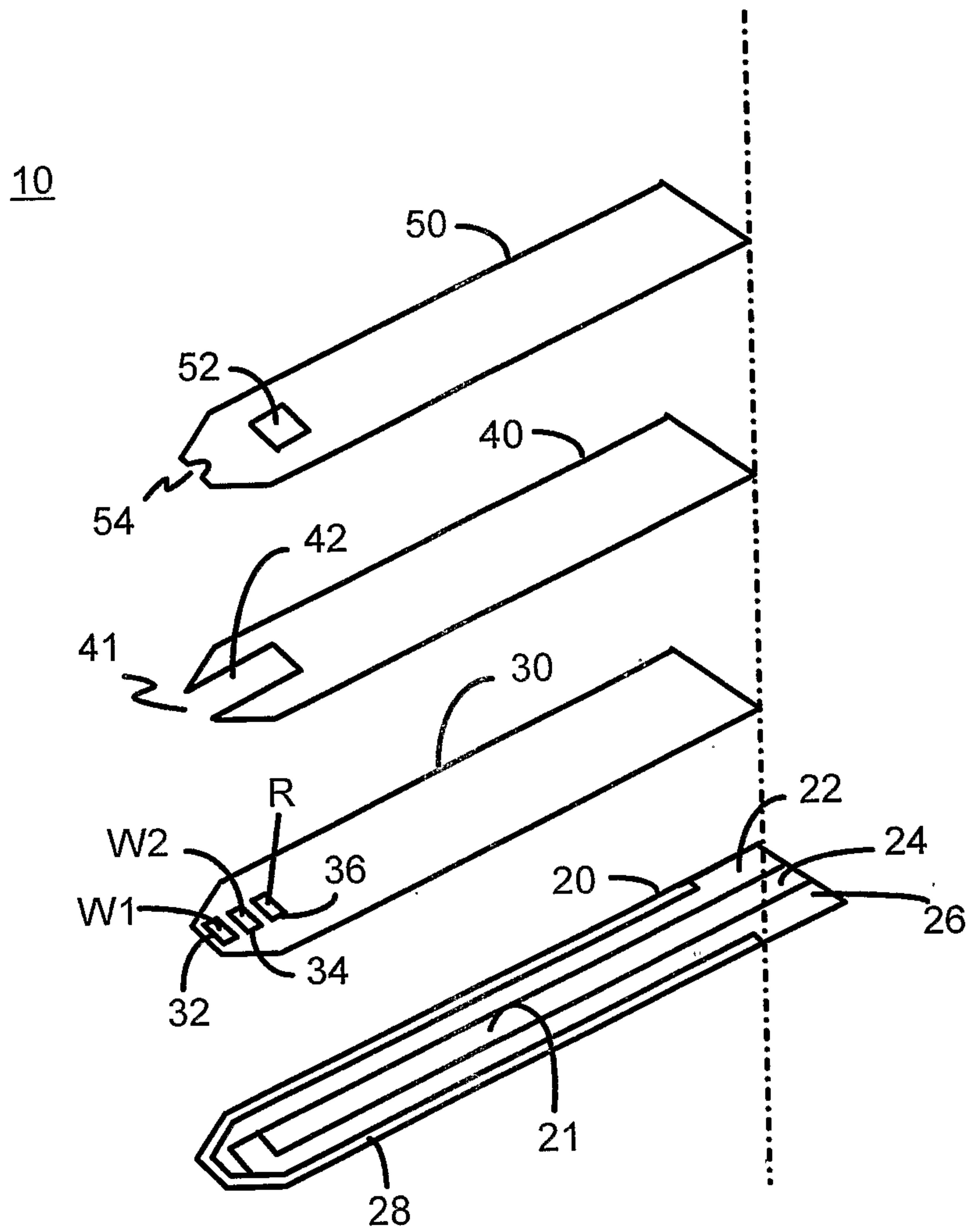

Fig. 2

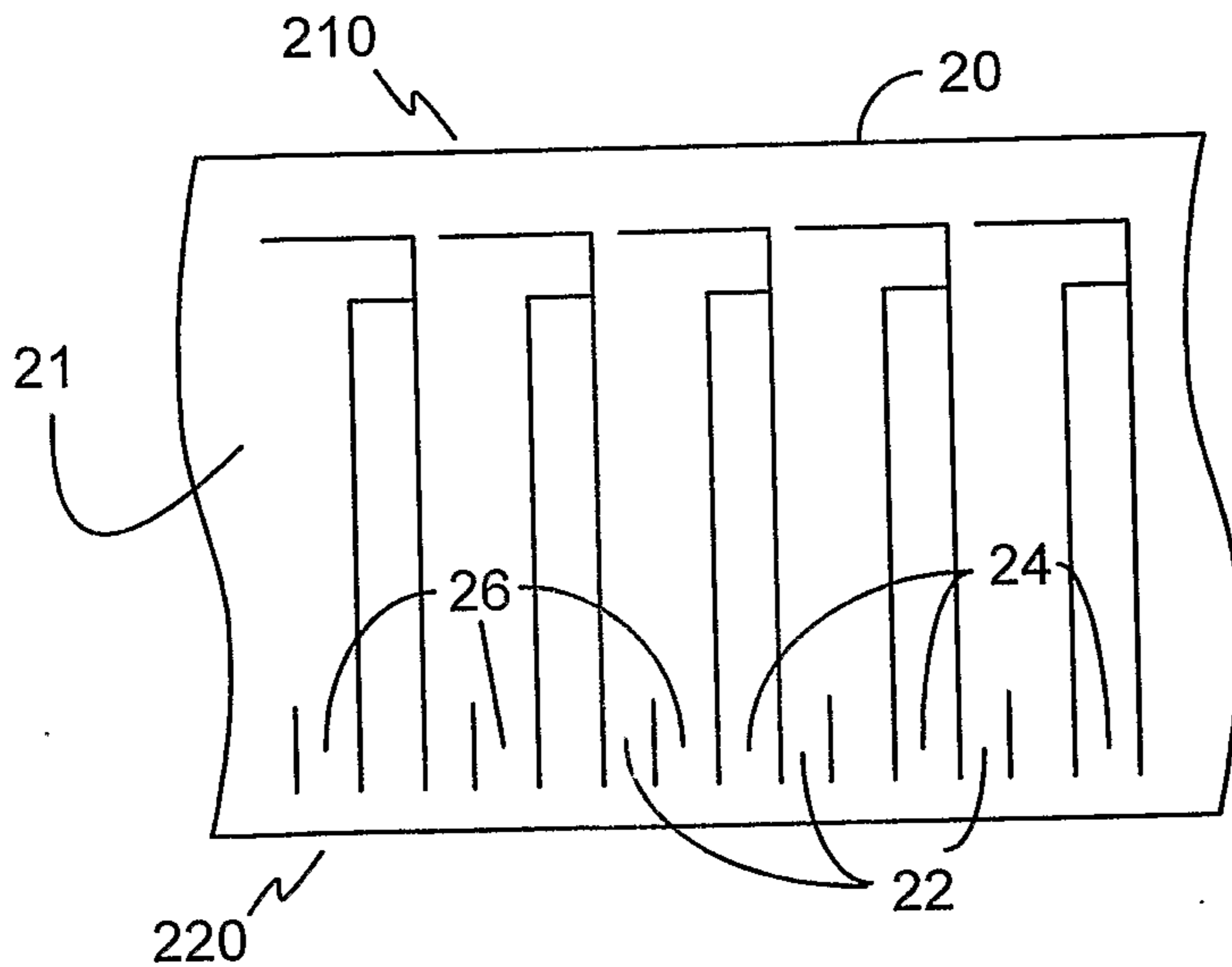

Fig. 3 A

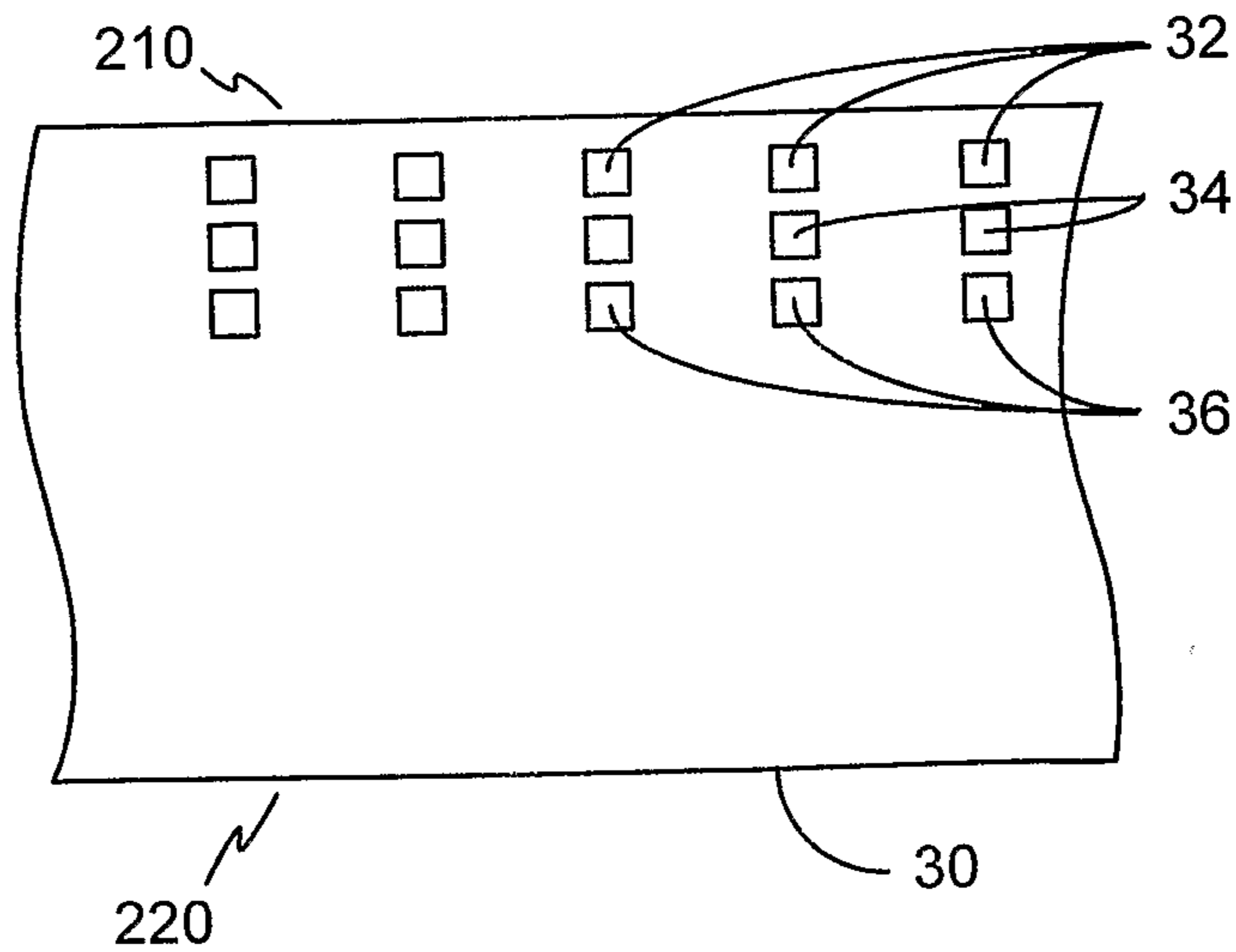

Fig. 3 B

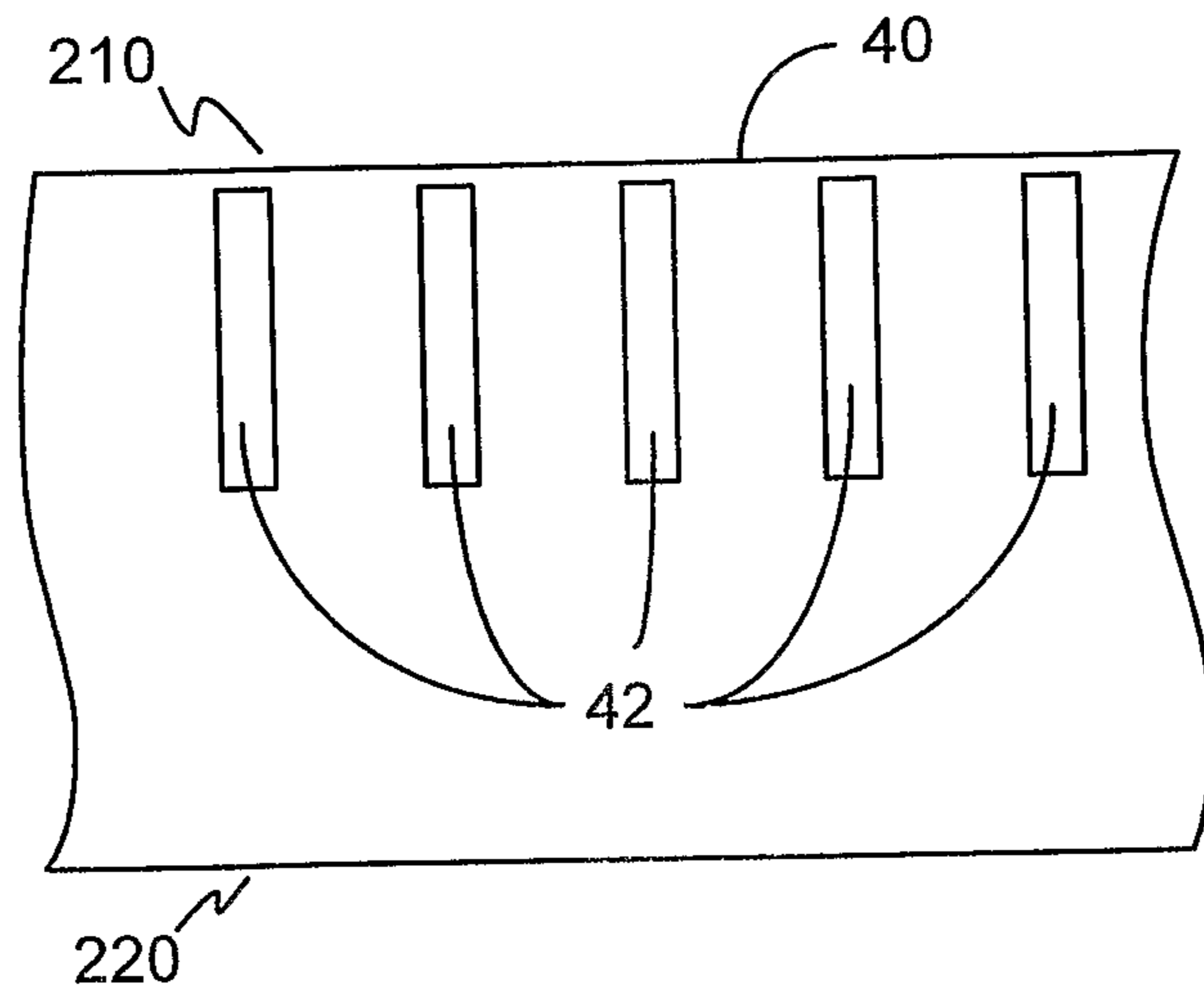

Fig. 3 C

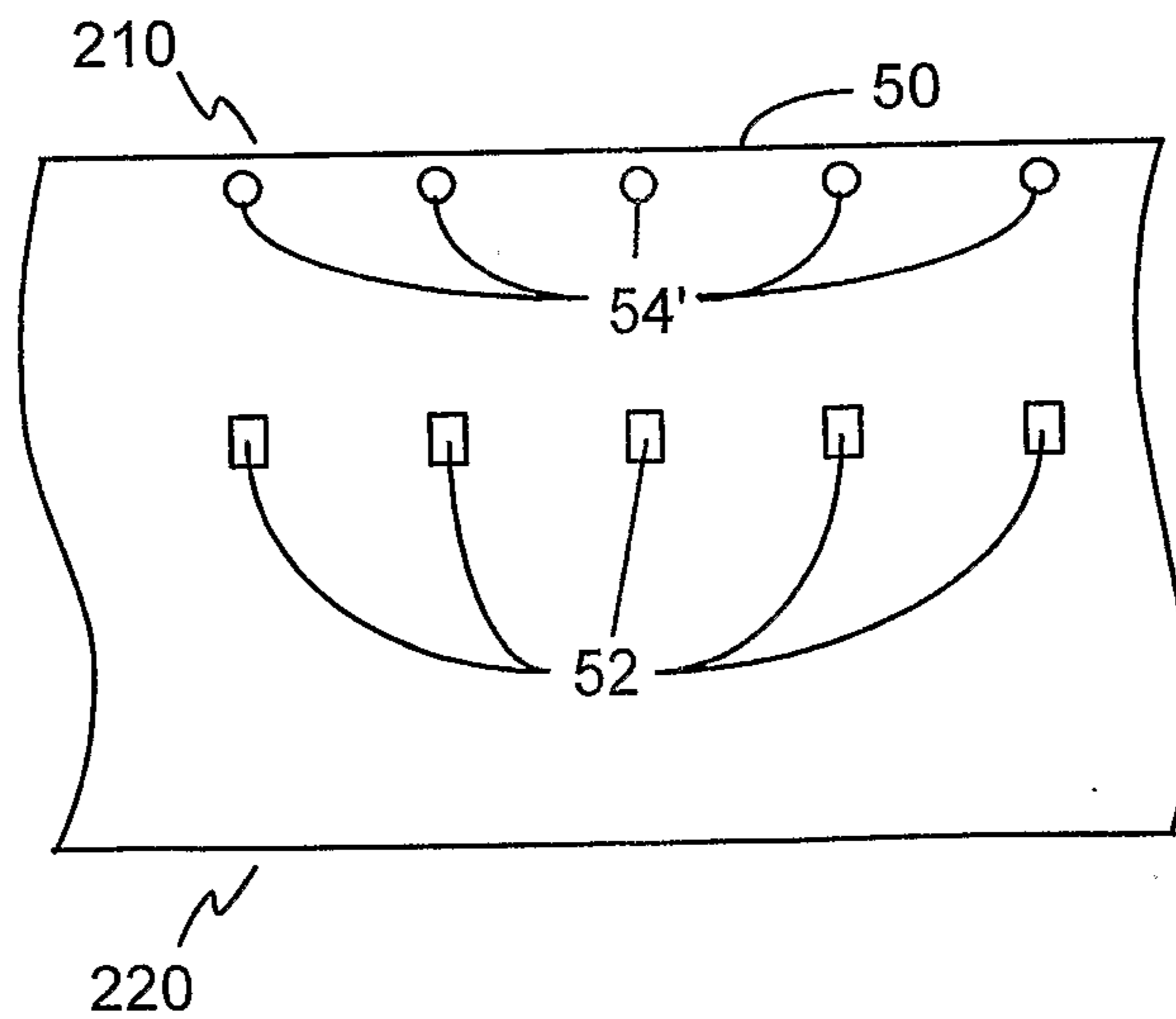

Fig. 3 D

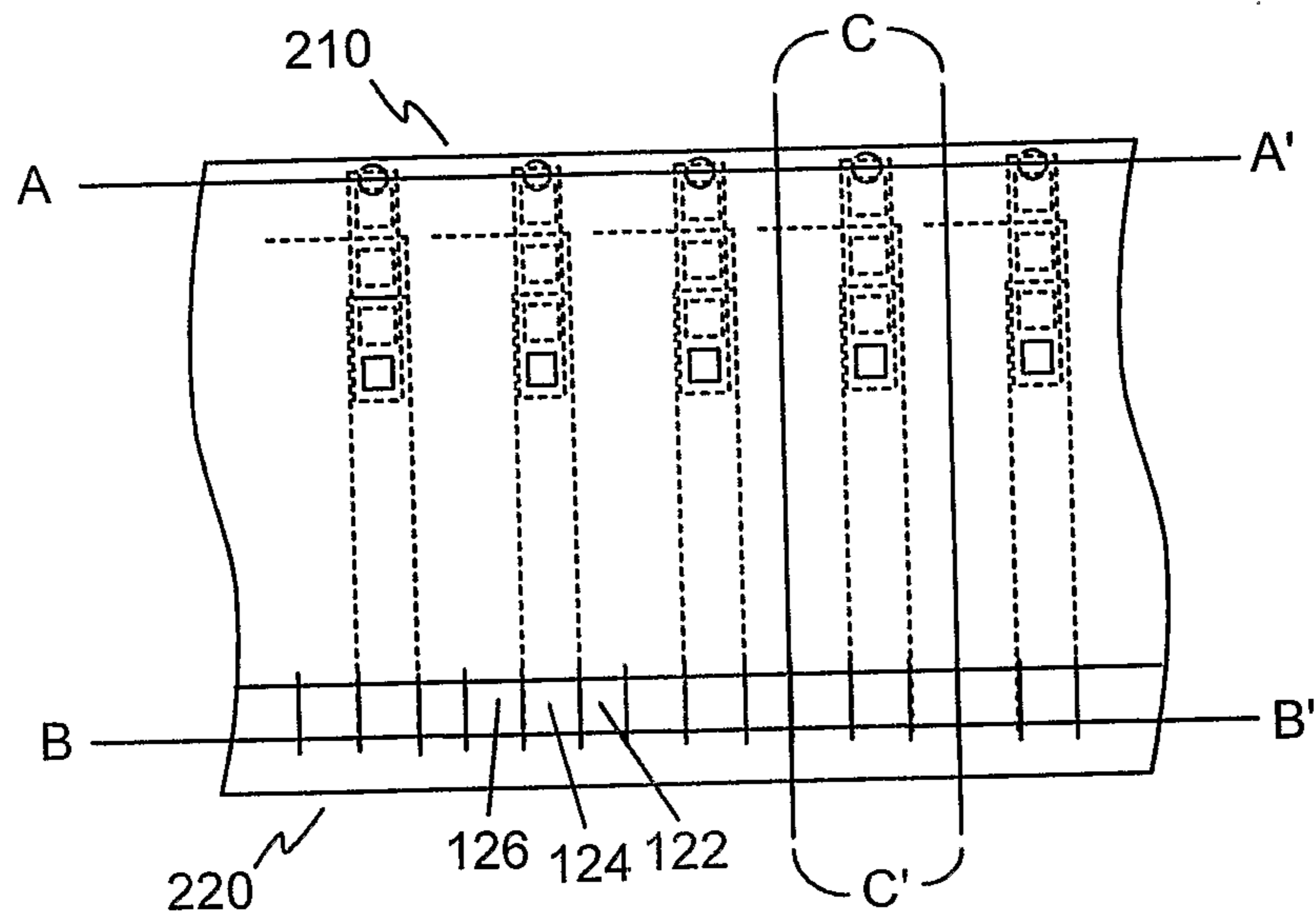

Fig. 3 E

10

