

M. J. BARRY.

Improvement in Apparatus for Manufacture of Gas from Oils.

No. 126,510.

Patented May 7, 1872.

Fig. 1.

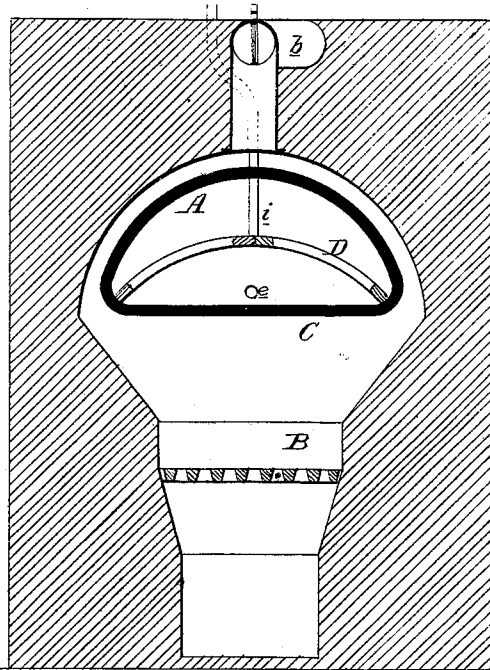
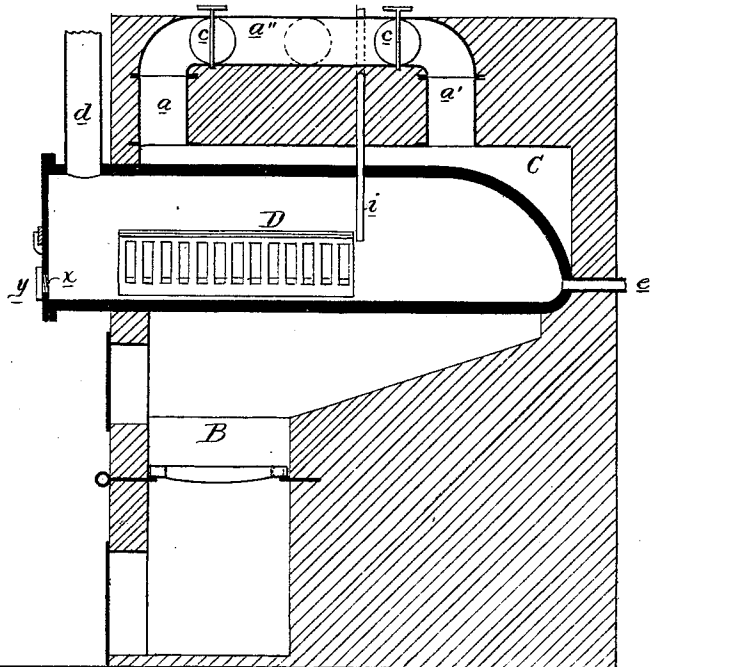

Fig. 2.



Witnesses.

Albert H. Norris
Flora Foster

Inventor.
M. J. Barry
by his atty.
Keown & Son

UNITED STATES PATENT OFFICE.

MATTHEW J. BARRY, OF WASHINGTON, DISTRICT OF COLUMBIA.

IMPROVEMENT IN APPARATUS FOR MANUFACTURE OF GAS FROM OILS.

Specification forming part of Letters Patent No. 126,510, dated May 7, 1872.

SPECIFICATION.

I, MATTHEW J. BARRY, of Washington, in the District of Columbia, have invented an Improvement in the Manufacture of Gas from Oils, of which the following is a specification:

My invention relates to the manufacture of gas from oils; and consists in discharging the oil directly upon the bottom of a retort, and then passing the gases through a mass of heated coke or its equivalent. The invention further consists of improvements, fully described hereafter, in the construction of the retort and furnace, whereby the rapid burning of the retort is prevented, and the cleansing of the same and removal of the contents are facilitated.

In the drawing, Figure 1 is a transverse sectional elevation of apparatus for carrying out my invention; Fig. 2, a longitudinal section.

A is a retort, which may be of cast-iron or other suitable material, and is supported by the walls of the furnace, within which, above the fire-place B, is a chamber, C. The top of the chamber C is arched to correspond to the curved top of the retort, leaving a space of some three inches in width between the two; and in the walls of the furnace, adjacent to the ends of the chamber C, are two vertical flues, *a a'*, both communicating with a horizontal flue, *a''*, and, through the latter, with a pipe, *b*, leading to a chimney. In the flue *a''*, near the opposite ends, are two dampers, *c c'*, the handles for regulating which are above the top of the furnace. The front end of the retort projects through and beyond the front wall of the furnace, and is provided with the usual detachable lid, in which is an opening, *x*, closed by a screw-stopper, *y*; and from the projecting part of the retort a tube, *d*, leads to the gas-main. Within the retort is arranged a grating, D, which, in the present instance, is arched, and which extends about one-third the length of the retort, and consists of two detachable sections connected at their inner edges. A tube, *e*, extends from the rear end of the retort to a bellows or other suitable blowing apparatus; and a tube, *i*, which extends through the top of the retort to the rear of the grating D, communicates with an oil-reservoir.

In the manufacture of gas from oil in the ordinary retorts it has heretofore been customary to place coke (or other suitable material) on the bottom of the retort and to discharge the oil directly upon the coke, which in a short time becomes clogged with carbonaceous matter, is thereby rendered unfit for use, and is soon so firmly cemented to the bottom of the retort that it could only be removed with difficulty after removing the cap from the retort. In ordinary gas apparatus, also, the heated gases from the furnace are all directed upon some one part of the retort, which speedily burns away, rendering the whole useless, and involving the necessity of frequent renewals at considerable expense.

In the apparatus above described the coke or other material is supported above the bottom of the retort by the grating D, but becomes sufficiently heated to afford an extended heating-surface for the vapors arising from the oil, which is discharged directly upon the bottom of the retort, while the latter may be maintained perfectly clean by means of scrapers introduced through the opening *x*; this operation being performed without cooling the retort or materially interfering with the production of gas. Inasmuch as the oil is not discharged directly upon the coke, the latter will not readily become clogged, and may be used for a long time. It may, however, be cleansed from condensed carbon by agitating the grating, and may be removed, when necessary, by drawing the grating from the retort.

Owing to the manner in which the retort is arranged in the chamber C, and to the arrangement of the flues *a a' a''*, the heated gases from the fire-place, when the valves *c c'* are arranged as shown, will completely envelop the retort, so that no portion will be heated unequally; but by closing one or other of the valves the heat may be directed to any part desired.

Without confining myself to the precise construction and arrangement of parts shown and described, I claim—

1. The manufacture of illuminating-gas from oil, by discharging the latter upon the bottom of an external case or retort which is exposed to the heated gases, and then passing it through

a body of heated coke, or its equivalent, supported by a grating arranged within the retort, all substantially as described.

2. The retort A, with the discharge-pipe *d* at one end and the feed-pipe *i* near the opposite end, and the intermediate suspended body of coke or its equivalent, as set forth.

3. The combination of the retort A, fireplace B, chamber C, and flues *a a'*, arranged and provided with valves, as described.

4. The opening *x* and detachable stopper *y* in the lid of the retort, for the purpose set forth.

In testimony whereof I have signed my name to this specification in the presence of two subscribing witnesses.

MATTHEW J. BARRY.

Witnesses:

ALBERT H. NORRIS,
W. R. NIMMO.