



(51) International Patent Classification:

H01M 2/10 (2006.01) *H01M 10/42* (2006.01)
H01M 2/12 (2006.01) *H01M 10/48* (2006.01)
H01M 2/34 (2006.01)

(21) International Application Number:

PCT/EP2020/078165

(22) International Filing Date:

07 October 2020 (07.10.2020)

(25) Filing Language:

English

(26) Publication Language:

English

(30) Priority Data:

19201729.1 07 October 2019 (07.10.2019) EP

(71) Applicant: **JT INTERNATIONAL SA** [CH/CH]; 8 rue Kazem Radjavi, 1202 Geneva (CH).

(72) Inventor: **ZOMINY, Claude**; 14, Place de l'Église, 74350 Copponex (FR).

(74) Agent: **GILL JENNINGS & EVERY LLP**; The Broadgate Tower, 20 Primrose Street, London EC2A 2ES (GB).

(81) Designated States (*unless otherwise indicated, for every kind of national protection available*): AE, AG, AL, AM, AO, AT, AU, AZ, BA, BB, BG, BH, BN, BR, BW, BY, BZ,

CA, CH, CL, CN, CO, CR, CU, CZ, DE, DJ, DK, DM, DO, DZ, EC, EE, EG, ES, FI, GB, GD, GE, GH, GM, GT, HN, HR, HU, ID, IL, IN, IR, IS, IT, JO, JP, KE, KG, KH, KN, KP, KR, KW, KZ, LA, LC, LK, LR, LS, LU, LY, MA, MD, ME, MG, MK, MN, MW, MX, MY, MZ, NA, NG, NI, NO, NZ, OM, PA, PE, PG, PH, PL, PT, QA, RO, RS, RU, RW, SA, SC, SD, SE, SG, SK, SL, ST, SV, SY, TH, TJ, TM, TN, TR, TT, TZ, UA, UG, US, UZ, VC, VN, WS, ZA, ZM, ZW.

(84) Designated States (*unless otherwise indicated, for every kind of regional protection available*): ARIPO (BW, GH, GM, KE, LR, LS, MW, MZ, NA, RW, SD, SL, ST, SZ, TZ, UG, ZM, ZW), Eurasian (AM, AZ, BY, KG, KZ, RU, TJ, TM), European (AL, AT, BE, BG, CH, CY, CZ, DE, DK, EE, ES, FI, FR, GB, GR, HR, HU, IE, IS, IT, LT, LU, LV, MC, MK, MT, NL, NO, PL, PT, RO, RS, SE, SI, SK, SM, TR), OAPI (BF, BJ, CF, CG, CI, CM, GA, GN, GQ, GW, KM, ML, MR, NE, SN, TD, TG).

Published:

— with international search report (Art. 21(3))

(54) Title: ENERGY STORAGE ASSEMBLY DEVICE FOR AN AEROSOL GENERATION DEVICE

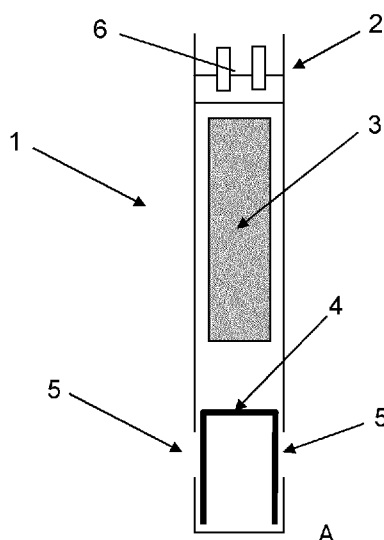

FIG.1

(57) Abstract: The invention provides an energy storage assembly device for an aerosol generation device, comprising a housing intended for housing a battery; a vent component configured to vent pressurized gases from within the housing upon a predetermined pressure in the housing; whereby the housing has an elongated shape; and the housing comprises on a circumference of the housing at a first extremity which is free on the inside from being filled by the battery, a first plurality of holes blinded by a blinding member, the first plurality of holes and the blinding member each being part of the vent component.



Energy storage assembly device for an aerosol generation device

Technical field

The invention is in the field of aerosol generation devices, and more specifically in safety aspects of using a battery in an aerosol generation device.

Background

Prior art reference US 2017/0170439 A1 is generally directed to an energy storage device. More specifically, it relates to an energy storage device assembly configured with a housing or container, a current interrupt device configured with the housing to electrically disconnect the energy storage assembly from communication current through its component, and a vent component/device configured to vent pressurized gases. A vent area substrate is configured to attach to the housing (e.g., lid and/or body), and the vent is configured to open in a predetermined manner such that the substrate tears/separates along a predetermined path across/around at least a portion of the substrate. In the disclosure of this document, the vent comprises a vent panel (e.g. an area having a reduced thickness, as compared to the body and/or cover, such that the vent area/vent panel is configured to tear/rupture at the location of reduced thickness.

Aerosol generation devices however inherently bring challenges for the design of the venting holes, because of the comparatively little space available in the body of the aerosol generation device, and particular aspects related to the external appearance of the aerosol generation device.

Furthermore, a design of an aerosol generation device and its energy storage assembly should be such to minimize any risk of harming the user.

The present invention aims at overcoming the challenges for the design of the venting holes, mentioned herein above.

Summary of invention

The invention provides an energy storage assembly device for an aerosol generation device, comprising a housing intended for housing a battery ; a vent component configured to vent pressurized gases from within the housing upon a predetermined pressure in the housing ; whereby the housing has an elongated shape ; and the housing comprises on a circumference of the housing at a first extremity which is free on the inside from being filled by the battery, a first plurality of holes blinded by a blinding member, the first plurality of holes and the blinding member each being part of the vent component.

In a preferred embodiment, the blinding member has towards the first plurality of holes a first visual aspect different from and contrasting with a second visual aspect of the

housing as visible from an outside, in a way that any blinding member alteration is easily visually detected by an intended user.

In a further preferred embodiment, each of the holes of the first plurality of holes has an oval shape, oriented according to a longitudinal direction of the elongated shape.

In a further preferred embodiment, the housing comprises on a circumference of the housing at a second extremity, opposite to the first extremity, which is free on the inside from being filled by the battery, a second plurality of holes blinded by a second blinding member, the second plurality of holes and the second blinding member each being part of the vent component.

In a further preferred embodiment, the blinding member blinds the plurality of holes from an inside of the housing.

In a further preferred embodiment, the blinding member comprises a sleeve configured to deform in case of the predetermined pressure occurring inside the housing to open the plurality of holes.

In a further preferred embodiment, the blinding member is configured to be pushed away from the plurality of holes to open at least a part of the plurality of holes in case of the predetermined pressure occurring inside the housing.

In a further preferred embodiment, the blinding member comprises a carrier configured to carry a printed circuit board assembly connecting to the battery through breakable electrical connections.

In a further preferred embodiment, the inside of the housing comprises a plurality of fixation points configured to fix the blinding member to the inside of the housing.

In a further preferred embodiment, the blinding member blinds the plurality of holes from the outside of the housing.

In a further preferred embodiment, the blinding member comprises a material from the list comprising a water-repellent coated sheet of material, such as silicon rubber or aluminum.

In a further preferred embodiment, the blinding member is made out of a same material as the wall of the housing; further a first wall thickness of housing wall portions corresponds to the blinding member blinding the first plurality of holes, is smaller than a second normal wall thickness of the housing, in order to enable a preferred rupture point at a location of the first plurality of holes.

In a further preferred embodiment, the energy storage assembly further comprises the battery housed in the housing, the battery comprises venting apertures configured to vent pressurized gases from inside the battery.

Brief description of the drawings

The invention will be better understood through the detailed description of preferred embodiments, and in reference to the drawings, wherein

figure 1 schematically illustrates in a sectional view an example embodiment for an energy storage assembly device for an aerosol generation device, according to the invention;

figure 2 schematically illustrates the example embodiment for an energy storage assembly device as shown in figure 1, after an intended battery has vented;

figure 3 schematically illustrates an example embodiment in a sectional view for an energy storage assembly device for an aerosol generation device, according to the invention;

figure 4 schematically illustrates the same example embodiment as in figure 3, after the intended battery has vented;

figure 5 schematically illustrates an example embodiment in a sectional view for an energy storage assembly device for an aerosol generation device, which is similar to that of figure 1;

figure 6 this schematically illustrates the example embodiment for an energy storage assembly device as shown in figure 5, after the intended battery has vented;

figures 7 and 8 illustrate schematic sectional views of an example embodiment for an energy storage assembly device for an aerosol generation device respectively in a normal usage situation and in a battery venting situation, according to the invention;

figures 9 and 10 illustrate a schematic and external view of an example embodiment for an energy storage assembly device, according to the invention;

figures 11 and 12 illustrate schematic sectional views of an example embodiment for an energy storage assembly device for an aerosol generation device respectively in a normal usage situation and in a battery venting situation, according to the invention;

figure 13 illustrates a schematic sectional view of an example embodiment for an energy storage assembly device for an aerosol generation device, similar as that shown in figure 11;

figure 14 illustrates an example for a first plurality of holes and a second plurality of holes in a housing, in a “rolled out” representation, according to the invention;

figure 15 illustrates a further example for the first plurality of holes and the second plurality of holes in the housing, in a “rolled out” representation, according to the invention;

figure 16 illustrates an example in which a wall thickness of the housing between each one of the first plurality of holes is reduced as compared to a normal wall thickness of the housing, according to the invention; and

figure 17 schematically illustrates a cross-section of the housing from figure 16, along a plane indicated by arrows C.

Same references will be used to designate same or similar features throughout the following description.

Detailed description of preferred embodiments

In case a battery cell is damaged inside an energy storage device, it may produce gases by a process of venting (also known as thermal runaway) that may increase a pressure inside the energy storage device and produce an over-heating. In case the energy storage device is used inside of an aerosol generation device, it should at all cost be avoided to harm an intended user. In order to avoid this, it is important to release the gases outside of the battery and energy storage device. One obvious way of releasing the gases is to provide one or more venting holes in the energy storage device allowing the gases to flow to the outside. However, such venting holes pose a security risk since they may allow water or liquid, e.g., e-liquid, to enter the energy storage device and potentially cause safety issues, such as a short circuit. Moreover, one or more venting holes may not provide any indication for the intended user to detect that the battery cell has vented unless the battery cell becomes fully inoperational after the venting. Such indication can provide the user with knowledge about the health state of the battery, so that the user can be informed to replace the battery or stop using the device, avoiding dangerous using situations.

The invention provides a solution for implementing venting holes in an energy storage device in which the venting holes are blinded by a blinding member during normal operation. In case of venting, the venting holes are opened by gas pressure as the blinding member is compressed by the pressure. Open holes may be observed by the intended user, providing the information that the battery cell has vented and that the device must be discarded.

The blinding member may comprise a material such as for example a water-repellent coated sheet of material, silicon rubber, aluminum, hence achieving a water resistant sealing during normal operation.

Referring to figure 1, this schematically illustrates in a sectional view an example embodiment for an energy storage assembly device **1** for an aerosol generation device (aerosol generation device not shown in figure 1). The energy storage assembly device **1** comprises a housing **2** intended for housing an intended battery **3**, the latter being illustrated in figure 1 for a better understanding, but is not necessary being part of the invention. A vent component **4, 5** is configured to vent pressurized gases (gases not illustrated in figure 1) from within the housing **2** upon a predetermined pressure in the housing **2**. Figure 1 further illustrates electrical contacts **6** which may be configured to contact the intended battery **3**. Such electrical contacts **6** may be considered to be standard equipment for any energy storage assembly device. The housing **2** has an elongated shape, which in the example of figure 1 is somehow rectangular when seen in the illustrated

section. The energy storage device assembly is a 3-dimensional device, which may for example be a hollow rectangular bar or a cylinder.

The housing **2** comprises on a circumference of the housing at a first extremity **A** which is free on the inside from being filled by the battery **3**, a plurality of holes **5** blinded by a blinding member **4**, both of the plurality of holes **5** and the blinding member **4** being part of the vent component.

Herein, an extremity refers to the region between a location where the battery **3** is intended to be arranged and an end of the housing. Accordingly, extremity **A** is not limited to the furthest part of the housing towards end **A**, and also includes a middle region as shown in Fig. 1. Furthermore, the plurality of holes **5** may be replaced with one single hole **5**.

The blinding member **4** has, at least towards the plurality of holes **5** a first visual aspect different from and contrasting with a second visual aspect of the housing **2** as visible from an outside, in a way that any blinding member alteration is easily visually detected by an intended user (visual aspects and intended user are not illustrated in figure 1). A visual aspect may be an effect that is perceivable by a human eye, such as for example an angle at which light is reflected, a surface pattern, a color. In the present example, the blinding member **4** is internal to the housing **2** and made out of a comparatively soft material, the reason for which will become apparent when discussing figure 2.

Referring to figure 2, this schematically illustrates the example embodiment for the energy storage assembly device **1** as shown in figure 1, after the battery **3** has vented. The venting causes the production of pressurized gas which exerts pressure toward the first extremity **A** as illustrated by thick arrows **20** and, in case a predetermined pressure occurs and is exceeded inside the housing **2**, pushes the blinding member **4** towards the first extremity **A**, thereby deforming the blinding member **4**, which is made comparatively easy due to the soft material out of which it is made. The venting holes **5** are opened allowing venting gases **21** to escape through them. In other words, the blinding member **4** is configured to be pushed away from the plurality of holes **5** to open at least a part of the plurality of holes **5** in case of the predetermined pressure occurring inside the housing **2**.

In a preferred embodiment, the first visual aspect and the second visual aspect are respectively a first color and a second color.

In a further preferred embodiment, the blinding member **4** may be a sleeve.

Referring to figure 3, this schematically illustrates in a sectional view a further example embodiment for an energy storage assembly device. One difference as compared to the example illustrated in figure 3, is that vent components **5**, **31**, in addition to the plurality of holes **5**, further comprise a carrier **31**, which carries or holds a PCBA **32** (Printed Circuit Board Assembly). The PCBA **32** may for example be configured to perform control of the aerosol generation device (other components of aerosol generation device not shown in figure 3). The carrier **31** is configured to blind the plurality of hole **5** during normal operation of the energy storage assembly, similar to the blinding member **4** known from

figure 1. The PCBA **32** is connected to the electrical contacts **6** by means of breakable electrical connections **33**.

The carrier **31**, similar to blinding member **4**, has, at least towards the plurality of holes **5**, the first visual aspect different from and contrasting with the second visual aspect of the housing **2** as visible from an outside, in a way that any carrier alteration is easily visually detected by an intended user (visual aspects and intended user are not illustrated in figure 3). A visual aspect may be an effect that is perceivable by a human eye, such as for example an angle at which light is reflected, a surface pattern, a color.

The carrier **31** may for example be a plastic frame.

Referring to figure 4, this schematically illustrates the example embodiment for the energy storage assembly as shown in figure 3, after the battery **3** has vented. The venting causes the production of pressurized gas which exerts pressure toward the first extremity **A** as illustrated by the thick arrow **20**, and, in case the predetermined pressure occurs and is exceeded inside the housing **2**, pushes the carrier **31** towards the first extremity **A**, thereby breaking the breakable electrical connections **33**. The venting holes **5** are opened allowing venting gases **21** to escape through them. In other words, the carrier **31** is configured to be pushed away from the plurality of holes **5** to open at least a part of the plurality of holes **5** in case of the predetermined pressure occurring inside the housing **2**. At the same time, the PCBA **32** is disconnected, since the breakable electrical connections **33** are broken, this having the effect of disconnecting the PCBA **32** from the battery, and thus the aerosol generation device cannot operate, preventing any potential adverse effect of operating the energy storage assembly and also preventing dangerous using cases when the battery has vented and not healthy to continue working.

Alternatively, the carrier **31** does not necessarily contain or hold PCBA and just performs its function without carrying any PCBA. In this embodiment, there are also no breakable electrical connections.

Referring to figure 5, this schematically illustrates an example embodiment in a sectional view for the energy storage assembly device **1** for an aerosol generation device, which is similar to that of figure 1. Again the intended battery **3** is illustrated in figure 5 for a better understanding, but is not a necessary part of the invention. In addition, the inside of the housing **2** comprises a plurality of fixation points **30** configured to fix the blinding member **4** to the inside of the housing **2**.

Referring to figure 6, this schematically illustrates the example embodiment of the energy storage assembly device **1** as shown in figure 5, after the battery **3** has vented. Figure 6 clearly shows how the fixation points **30** help to retain the blinding member **4** as this is deformed under the effect of pressurized gas.

Referring to figures 7 and 8, these illustrate schematic sectional views of an example embodiment for an energy storage assembly device for an aerosol generation device respectively in a normal usage situation and in a battery venting situation. Unlike figures

1 and 2, a blinding member **70** covers the first plurality of holes **5** from an outside of the sealing housing **2**. In case of the battery venting in figure 10, the pressurized gas pushes the blinding member **70** and opens at least some of the first plurality of holes **5** in order to escape from the inside of the housing **2**.

Referring to figures 9 and 10, these illustrate a schematic and external view of an example embodiment for an energy storage assembly device **50**, in which the housing **2** comprises on a circumference of the housing **2** at a second extremity **B**, opposite to the first extremity **A**, which is free on the inside from being filled by the battery (not illustrated in figures 9 and 10), a second plurality of holes **51** blinded from the inside by a second blinding member **52**, both of the second plurality of holes **51** and second sleeve **52** being part of the vent component.

Herein, an extremity refers to the region between a location where the battery **3** is intended to be arranged and an end of the housing. Accordingly, extremity **B** is not limited to the furthest part of the housing towards end **B**, and also includes a middle region as shown in Fig. 9. Furthermore, the plurality of holes **51** may be replaced with one single hole **51**.

Figures 9 and 10 further illustrate the first plurality of holes **5**, which in figure 9 are covered from the inside by the blinding member **4**, but in figure 10, due to a venting of the battery (battery not shown in figures 9 and 10), only a part of the first plurality of holes **5** remain covered from the inside by the blinding member **4**, while one hole **53** of the first plurality of holes **5** is not covered anymore but opened to let gas escape through it. The one hole **53** is clearly identifiable by an intended user, and indicates that the battery has vented and the device should be discarded.

Each of the first plurality of holes **5** or the second plurality of holes **51** may have a shape that is adapted to an amount of gas to be vented in case of battery venting, including a round shape, an oval shape, a rectangular shape, a polygon shape etc. (some of these shapes are not illustrated in figures 9 and 10).

In a preferred embodiment, each of the holes of the first plurality of holes **5** has an oval shape, oriented according to a longitudinal direction of the elongated shape. This is as illustrated in figures 9 and 10.

The energy storage assembly device is assembled into an aerosol generation device in a way that the first extremity **A** corresponds to or close to the non-inhalation end of the aerosol generation device, an end opposite to the inhalation side of the aerosol generation device. This is because the pressurized gas is hot and dangerous to user, and safer to be vented out far from the inhalation side.

Referring to figures 11 and 12, these illustrate schematic sectional views of for an energy storage assembly device for an aerosol generation device respectively in a normal usage situation and in a battery venting situation. Figures 11 and 12 show a use case scenario for the first plurality of holes **5** and the second plurality of holes **51** already illustrated in figures 9 and 10, whereby no blinding member is illustrated in figures 11 and 12, this

having already been explained from previous examples where the blinding member was either covering holes from the inside or the outside. Any of the previously described specificities may be implemented in the present structure of arranging holes on both extremities.

During a thermal runaway / dysfunction of the battery **3**, the latter may swell, for example at a location **90** indicated both in figures 11 and 12, whereby the swelling of the battery **3** may be seen in figure 12 only, thereby filling a possible gap between the battery **3** and the housing **2**, and potentially blocking gases in an area of the housing **2** without any possible release. Having holes situated at both extremities of the housing **2**, embodied for example as the first plurality of holes **5** and the second plurality of holes **51**, allows gas to evacuate in any situation and avoid the blocking of gases.

Referring to figure 13, this illustrates a schematic sectional view of an example embodiment for an energy storage assembly device for an aerosol generation device, similar as that shown in figure 11. It is reminded that in case of a thermal runaway / dysfunction of the battery **3**, and even in the presence of the first plurality of holes **5** and the second plurality of holes **51** in the housing **2**, it may happen that a volume of gas generated cannot be released sufficiently fast from the housing **2**, thus over-pressuring the battery **3** and/or the housing **2**, which in turn may cause any one of the latter two to break in an unpredictable way. It is therefore important, especially when the energy storage assembly device is used in an aerosol generation device, to generate in the housing **2** by means of a mechanical machining process a predefined rupture scheme, i.e., a weak point, preferably at the opposite of the intended user's face.

Many different rupture schemes may be realised, involving size, shape and distribution of holes, but also types of blinding member and thickness of wall(s).

Figure 14 illustrates an example for the first plurality of holes **5** and the second plurality of holes **51** in the housing **2**, in a "rolled out" representation. The holes of the second plurality of holes **51** have a smaller diameter than the holes of the first plurality of holes **5**, while the counts of the second plurality of holes **51** and the first plurality of holes **5** are the same. Thus a first surface (of blinding member, not represented in figure 14) presented by the first plurality of holes **5** is greater than a second surface presented by the second plurality of holes **51**, making it more likely in a case of pressure buildup that the gas would escape with a greater flow through the first plurality of holes **5**, and further making this side to be located in the aerosol generation device away from the intended user's face (aerosol generation device and intended user's face not illustrated in figure 14). This is because the pressurized gas is hot and dangerous to user, and safer to be vented out far from the inhalation side. Also, and importantly, there is less material of the housing **2** remaining around the first plurality of holes **5**, than around the second plurality of hole **51**, making it more likely that the housing **2** would rupture in the area of the first plurality of holes **5** in case of extreme pressure buildup inside the housing **2**.

The first plurality of holes **5** may be confined to a determined section **141**, and the first plurality of holes **5** covers a first hole's surface that corresponds to, e.g., 50 % of the determined section **141**. The percentage can be shifted larger or smaller depending on design of the aerosol generation device.

The second plurality of holes **51** may be confined to a second determined section **142**, and the second plurality of holes **51** covers a second hole's surface that corresponds to, e.g., 25 % of the second determined section **142**. The percentage can be shifted larger or smaller depending on design of the aerosol generation device.

Figure 15 illustrates a further example for the first plurality of holes **5** and the second plurality of holes **51** in the housing **2**, in a "rolled out" representation. The holes of the second plurality of holes **51** have a similar diameter than the holes of the first plurality of holes **5**, and their numbers are the same. Thus a first surface (of blinding member, not represented in figure 15) represented by the first plurality of holes **5** is substantially the same than a second surface presented by the second plurality of holes **51**, making it likely in a case of pressure buildup that the gas would escape with a similar flow through the first plurality of holes **5** as through the second plurality of holes **51**. However, it is possible, as illustrated in figure 16, to engineer each of the holes of the first plurality of holes **5** to be blinded by walls **140**, for example, such that a wall thickness of the walls **140** is lesser than a normal wall thickness of the housing **2**, making it more likely that a rupture of the wall occurs at the part with thinner walls in case of extreme pressure buildup. Figure 17 schematically illustrates a cross-section of the housing **2** along a plane indicated by arrows C in figure 16, showing how a thickness **w** of walls **140**, is lesser than that of the normal wall thickness **h** of the housing **2**. The side of the housing **2** at which the holes connected by thinner walls is located should be oriented away from the intended user's face when designing the aerosol generation device, in order to reducing risks of injury.

Claims

1. An energy storage assembly device for an aerosol generation device, comprising
a housing intended for housing a battery ;
a vent component configured to vent pressurized gases from within the housing
upon a predetermined pressure in the housing ;
whereby the housing has an elongated shape ; and
the housing comprises on a circumference of the housing at a first extremity
which is free on the inside from being filled by the battery, a first plurality
of holes blinded by a blinding member, the first plurality of holes and the
blinding member each being part of the vent component.
2. The energy storage assembly device of claim 1, wherein
the blinding member has towards the first plurality of holes a first visual aspect
different from and contrasting with a second visual aspect of the housing
as visible from an outside, in a way that any blinding member alteration is
easily visually detected by an intended user.
3. The energy storage assembly of claim 2,
wherein each of the holes of the first plurality of holes has an oval shape,
oriented according to a longitudinal direction of the elongated shape.
4. The energy storage assembly of either one of claims 1 to 3,
wherein the housing comprises on a circumference of the housing at a second
extremity, opposite to the first extremity, which is free on the inside from
being filled by the battery, a second plurality of holes blinded by a second
blinding member, the second plurality of holes and the second blinding
member each being part of the vent component.
5. The energy storage assembly of any one of claims 1 to 4,
wherein the blinding member blinds the plurality of holes from an inside of the
housing.
6. The energy storage assembly of any one of claims 1 to 5,

wherein the blinding member comprises a sleeve configured to deform in case of the predetermined pressure occurring inside the housing to open the plurality of holes.

7. The energy storage assembly of claim 6,
wherein the blinding member is configured to be pushed away from the plurality of holes to open at least a part of the plurality of holes in case of the predetermined pressure occurring inside the housing.
8. The energy storage assembly of claim 7,
wherein the blinding member comprises a carrier configured to carry a printed circuit board assembly connecting to the battery through breakable electrical connections.
9. The energy storage assembly of any one of claims 5 to 8,
wherein the inside of the housing comprises a plurality of fixation points configured to fix the blinding member to the inside of the housing.
10. The energy storage assembly of any one of claims 1 to 4,
wherein the blinding member blinds the plurality of holes from the outside of the housing.
11. The energy storage assembly of any one of claims 1 to 10,
wherein the blinding member comprise a material from the list comprising a water-repellent coated sheet of material, such as silicon rubber or aluminum.
12. The energy storage assembly of claim 1,
wherein the blinding member is made out of a same material as the wall of the housing;
further wherein a first wall thickness of housing wall portions corresponding to the blinding member blinding the first plurality of holes, is smaller than a second normal wall thickness of the housing, in order to enable a preferred rupture point at a location of the first plurality of holes.

13. The energy storage assembly of any one of claims 1 to 12, further comprising the battery housed in the housing, the battery comprises venting apertures configured to vent pressurized gases from inside the battery.

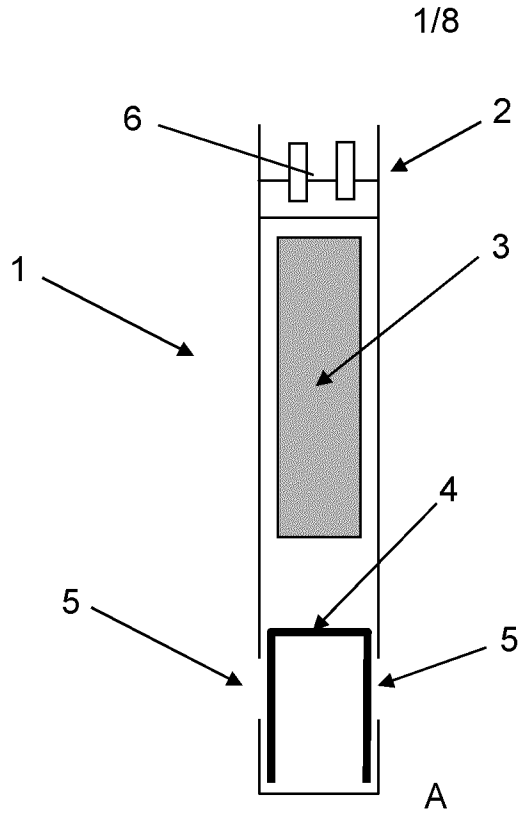

FIG.1

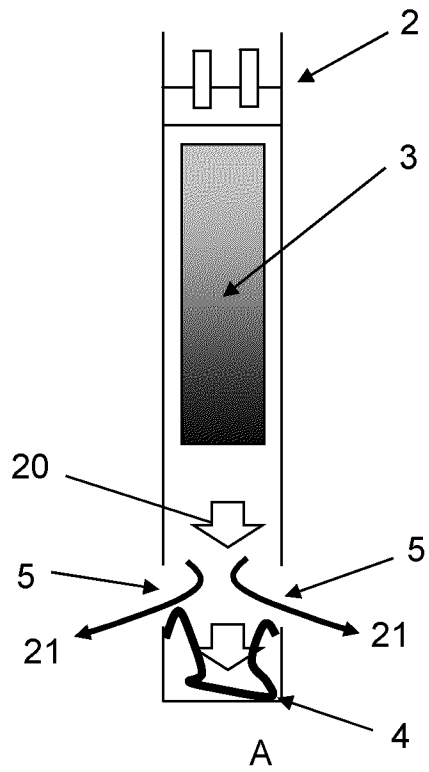

FIG.2

2/8

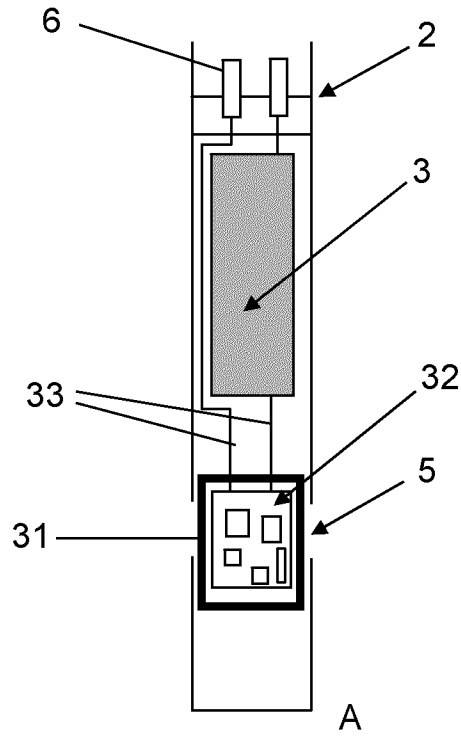

FIG. 3

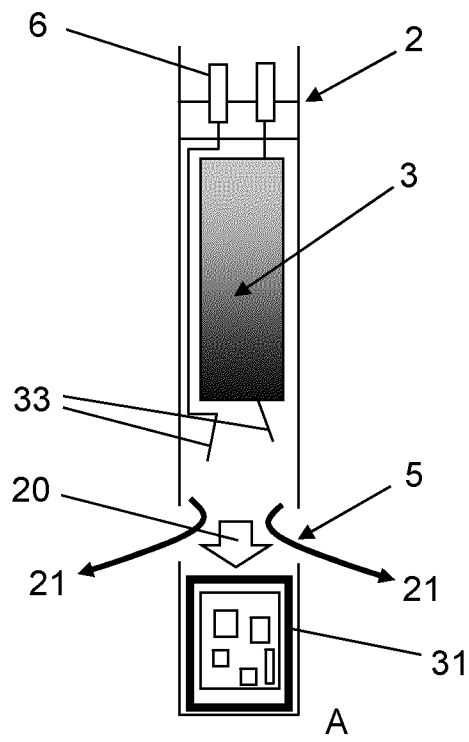

FIG. 4

3/8

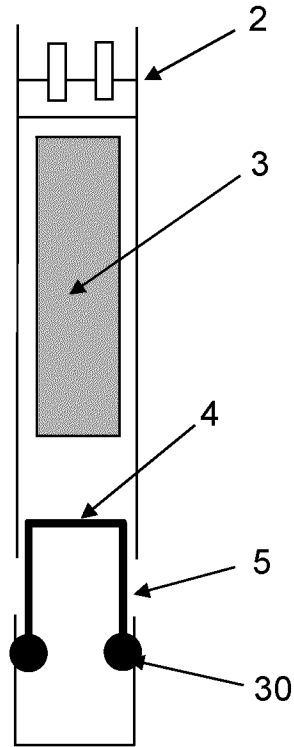

FIG. 5

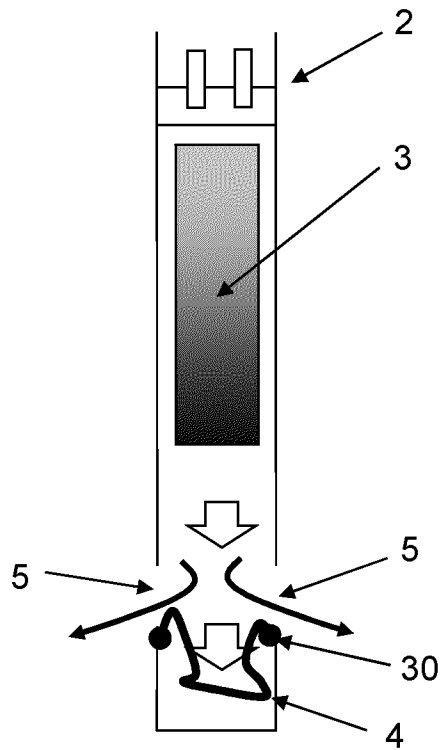

FIG. 6

4/8

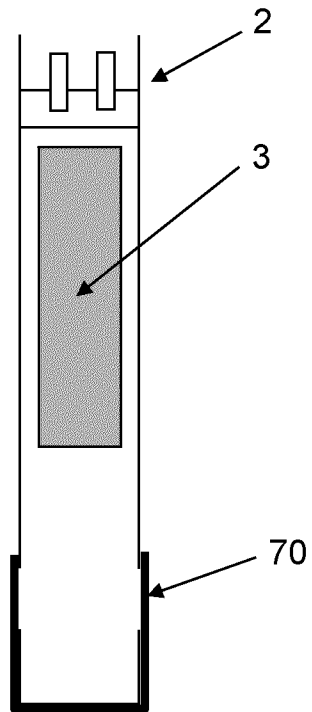

FIG. 7

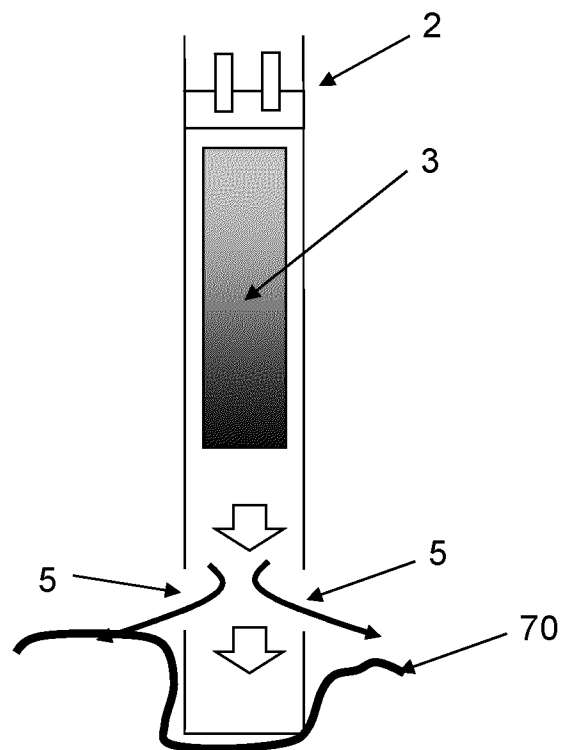

FIG. 8

5/8

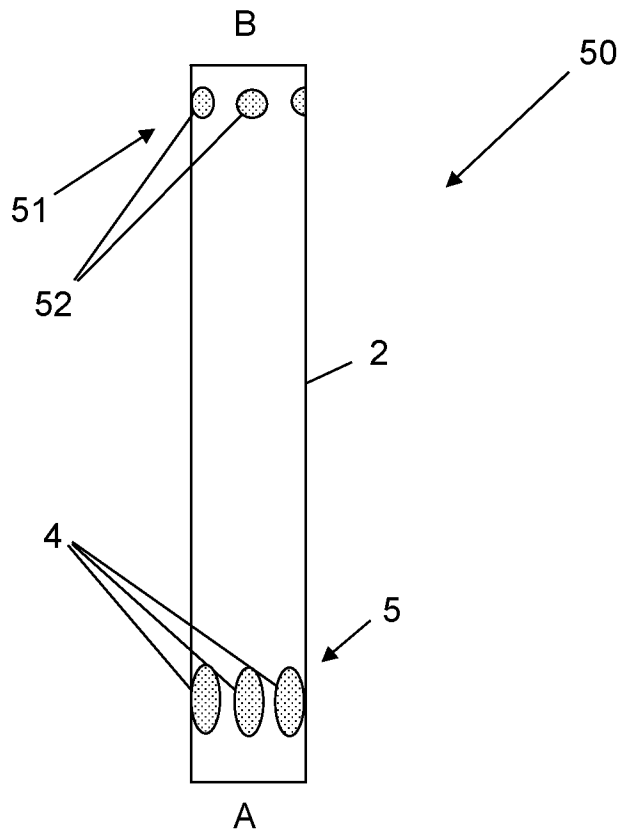

FIG. 9

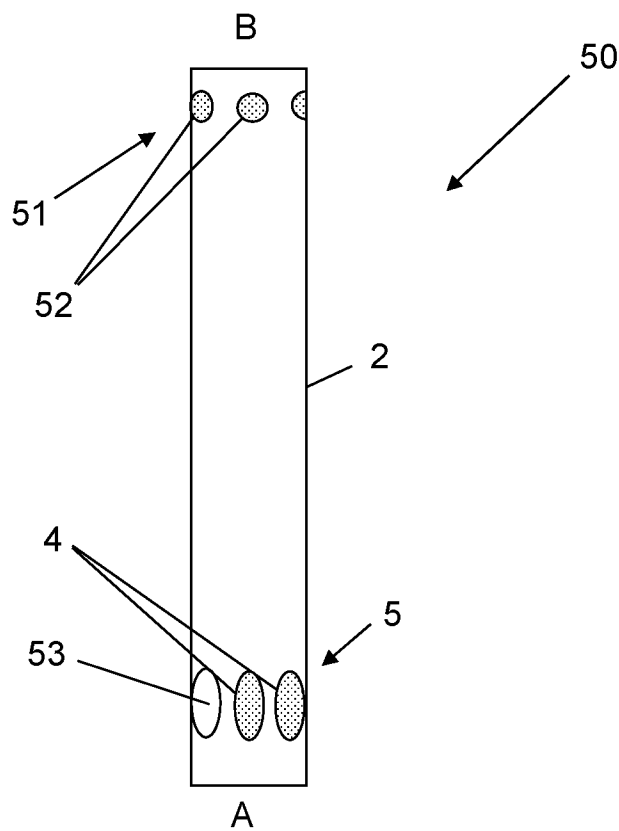

FIG. 10

6/8

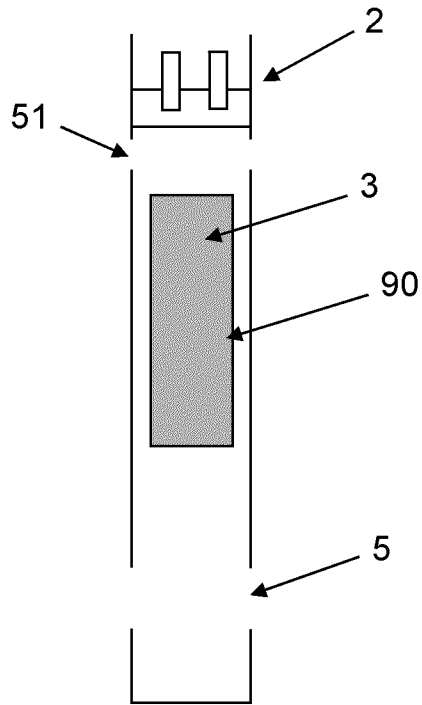

FIG. 11

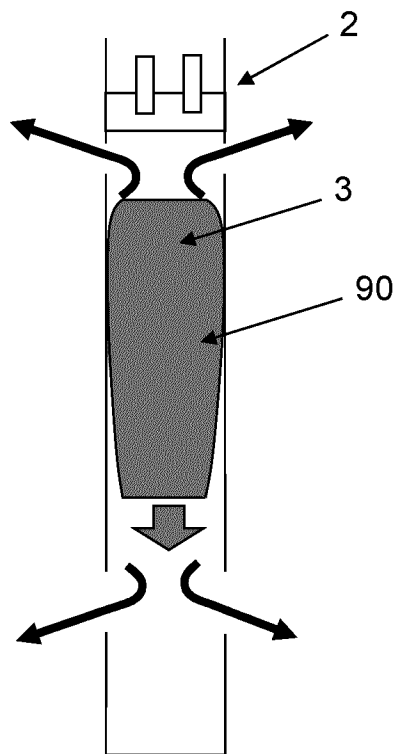

FIG. 12

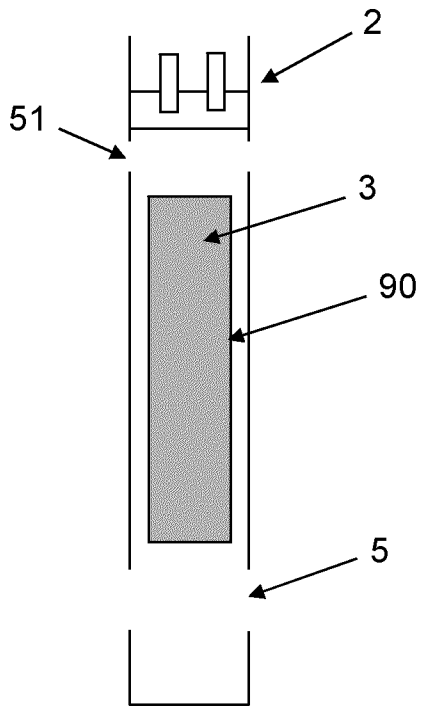

FIG. 13

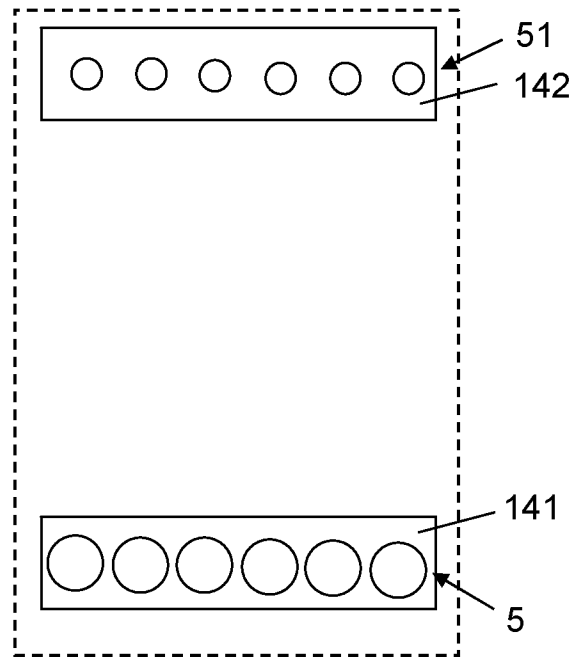

FIG. 14

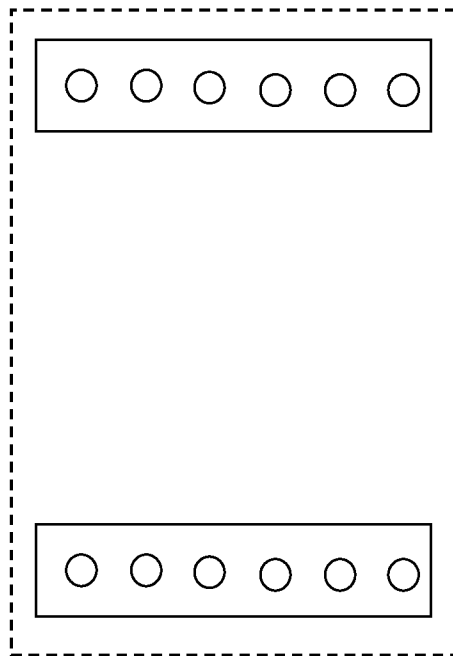

FIG. 15

8/8

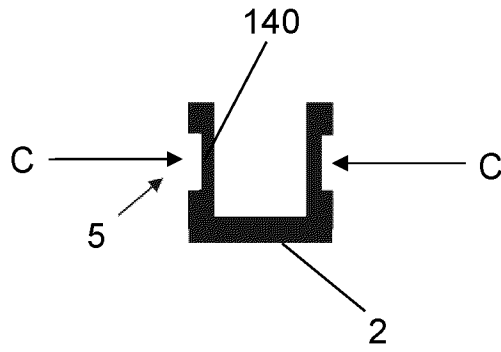

FIG. 16

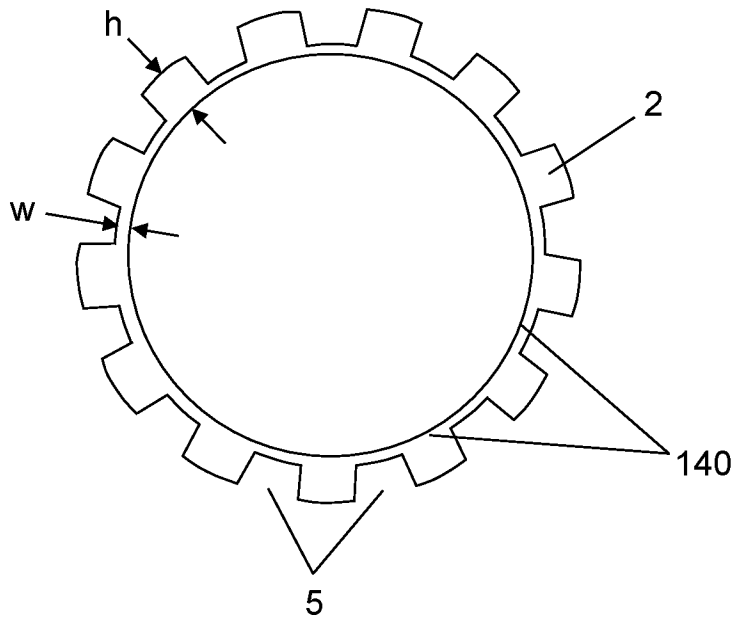

FIG. 17

INTERNATIONAL SEARCH REPORT

International application No
PCT/EP2020/078165

A. CLASSIFICATION OF SUBJECT MATTER
 INV. H01M2/10 H01M2/12 H01M2/34 H01M10/42 H01M10/48
 ADD.
 According to International Patent Classification (IPC) or to both national classification and IPC

B. FIELDS SEARCHED
 Minimum documentation searched (classification system followed by classification symbols)
 H01M

Documentation searched other than minimum documentation to the extent that such documents are included in the fields searched

Electronic data base consulted during the international search (name of data base and, where practicable, search terms used)
 EPO-Internal, WPI Data

C. DOCUMENTS CONSIDERED TO BE RELEVANT

Category*	Citation of document, with indication, where appropriate, of the relevant passages	Relevant to claim No.
X	US 2016/218336 A1 (HERRMANN AMY T [US] ET AL) 28 July 2016 (2016-07-28)	1,4-13
Y	paragraphs [0015] - [0026] figure 3	2,3
X	WO 2016/026051 A1 (CORVUS ENERGY LTD [CA]) 25 February 2016 (2016-02-25)	1,5-7,13
X	US 2017/170439 A1 (JARVIS GLENN W [US] ET AL) 15 June 2017 (2017-06-15)	1,5-7, 12,13
Y	US 2014/154536 A1 (COUPAR THOMAS J [US] ET AL) 5 June 2014 (2014-06-05)	2,3
	paragraphs [0016] - [0026] figure 2	

Further documents are listed in the continuation of Box C.

See patent family annex.

* Special categories of cited documents :

- "A" document defining the general state of the art which is not considered to be of particular relevance
- "E" earlier application or patent but published on or after the international filing date
- "L" document which may throw doubts on priority claim(s) or which is cited to establish the publication date of another citation or other special reason (as specified)
- "O" document referring to an oral disclosure, use, exhibition or other means
- "P" document published prior to the international filing date but later than the priority date claimed

- "T" later document published after the international filing date or priority date and not in conflict with the application but cited to understand the principle or theory underlying the invention
- "X" document of particular relevance; the claimed invention cannot be considered novel or cannot be considered to involve an inventive step when the document is taken alone
- "Y" document of particular relevance; the claimed invention cannot be considered to involve an inventive step when the document is combined with one or more other such documents, such combination being obvious to a person skilled in the art
- "&" document member of the same patent family

Date of the actual completion of the international search 14 December 2020	Date of mailing of the international search report 22/12/2020
---	--

Name and mailing address of the ISA/ European Patent Office, P.B. 5818 Patentlaan 2 NL - 2280 HV Rijswijk Tel. (+31-70) 340-2040, Fax: (+31-70) 340-3016	Authorized officer Rolle, Susett
--	---

INTERNATIONAL SEARCH REPORT

Information on patent family members

International application No PCT/EP2020/078165

Patent document cited in search report	Publication date	Patent family member(s)	Publication date	
US 2016218336	A1	28-07-2016	CN 107210403 A	26-09-2017
			GB 2550714 A	29-11-2017
			US 2016218336 A1	28-07-2016
			WO 2016123020 A1	04-08-2016

WO 2016026051	A1	25-02-2016	US 2017288186 A1	05-10-2017
			WO 2016026051 A1	25-02-2016

US 2017170439	A1	15-06-2017	CN 106856232 A	16-06-2017
			CN 206907805 U	19-01-2018
			EP 3357108 A1	08-08-2018
			JP 2018538655 A	27-12-2018
			US 2017170439 A1	15-06-2017
			WO 2017059419 A1	06-04-2017

US 2014154536	A1	05-06-2014	CN 103847496 A	11-06-2014
			DE 102013224356 A1	04-12-2014
			US 2014154536 A1	05-06-2014
