



(51) International Patent Classification:

A63B 7/00 (2006.01) A63B 69/00 (2006.01)
A63B 22/00 (2006.01) A63J 7/00 (2006.01)

(21) International Application Number:

PCT/CA2018/000165

(22) International Filing Date:

04 September 2018 (04.09.2018)

(25) Filing Language:

English

(26) Publication Language:

English

(30) Priority Data:

2,978,058 01 September 2017 (01.09.2017) CA

(71) Applicant: **FYRE-FLY PERFORMANCE INC.**
[CA/CA]; 3812 Macleod Trail, Calgary, AB T2G 2R2 (CA).

(72) Inventors: **NELSON, Christine Marie**; 10731 Willowgreen Drive SE, Calgary, Alberta T2J 1P7 (CA). **WILHELM, Donald Leon**; 10731 Willowgreen Drive SE, Calgary, Alberta T2J 1P7 (CA). **DIAMOND, Lynde Starr**;

211-300 Marina Drive, Chestermere, Alberta T1X 0P6 (CA).

(74) Agent: **PIGEON, Charles O.**; Burnet, Duckworth & Palmer LLP, 2400, 525 - 8th Avenue SW, Calgary, Alberta T2P 1G1 (CA).

(81) Designated States (unless otherwise indicated, for every kind of national protection available): AE, AG, AL, AM, AO, AT, AU, AZ, BA, BB, BG, BH, BN, BR, BW, BY, BZ, CA, CH, CL, CN, CO, CR, CU, CZ, DE, DJ, DK, DM, DO, DZ, EC, EE, EG, ES, FI, GB, GD, GE, GH, GM, GT, HN, HR, HU, ID, IL, IN, IR, IS, JO, JP, KE, KG, KH, KN, KP, KR, KW, KZ, LA, LC, LK, LR, LS, LU, LY, MA, MD, ME, MG, MK, MN, MW, MX, MY, MZ, NA, NG, NI, NO, NZ, OM, PA, PE, PG, PH, PL, PT, QA, RO, RS, RU, RW, SA, SC, SD, SE, SG, SK, SL, SM, ST, SV, SY, TH, TJ, TM, TN, TR, TT, TZ, UA, UG, US, UZ, VC, VN, ZA, ZM, ZW.

(84) Designated States (unless otherwise indicated, for every kind of regional protection available): ARIPO (BW, GH, GM, KE, LR, LS, MW, MZ, NA, RW, SD, SL, ST, SZ, TZ, UG, ZM, ZW), Eurasian (AM, AZ, BY, KG, KZ, RU, TJ, TM), European (AL, AT, BE, BG, CH, CY, CZ, DE, DK,

(54) Title: SUSPENSION RIG FOR AEROBICS

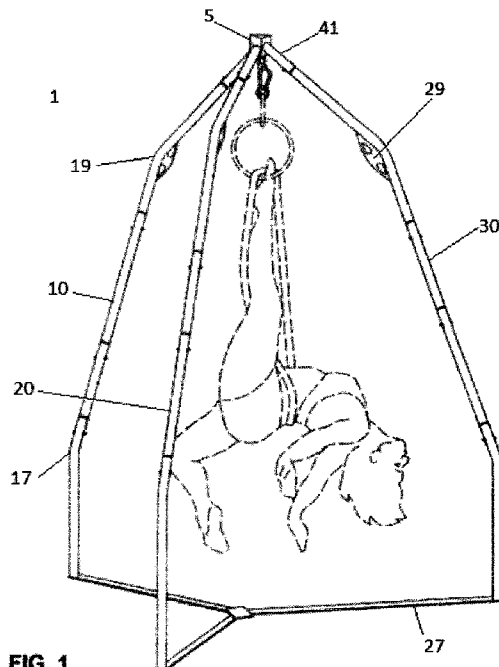

FIG. 1

(57) Abstract: The present invention provides for a suspension rig for use in aerial acrobatics, said rig comprising: at least three main vertical supports, each one of the at least three main vertical supports comprising: - a top extremity; and - a bottom extremity, said bottom extremity being adapted to rest on a surface and arranged equidistant from one another and said each one of said top extremity meeting the top extremity of each of the other main vertical supports at an apex; and means for suspending an individual; said means for suspending an individual being connected to said suspension rig underneath the apex.



EE, ES, FI, FR, GB, GR, HR, HU, IE, IS, IT, LT, LU, LV,
MC, MK, MT, NL, NO, PL, PT, RO, RS, SE, SI, SK, SM,
TR), OAPI (BF, BJ, CF, CG, CI, CM, GA, GN, GQ, GW,
KM, ML, MR, NE, SN, TD, TG).

Published:

— *with international search report (Art. 21(3))*

SUSPENSION RIG FOR AEROBICS

FIELD OF THE INVENTION

The present invention is directed to an exercise device, more specifically to a device used for dancers or acrobats to perform manoeuvres in an individual setting in a small area.

BACKGROUND OF THE INVENTION

Exercise is becoming increasingly prevalent in a society geared towards clean eating and more exercising. The variety of exercise ultimately leads to more people exercising. One exercise that is becoming more popular is yoga. A related type of exercise involves stretching and various aerobic maneuvers. Of course, aerobics have been around for a long period of time but in most cases aerobic exercises requires the presence of individuals to prevent injuries or simply to perform the routines. In that regard, several patents/patent applications teach a variety of devices to aid in performing aerobics. The following provides a list of the more relevant ones that are known to exist.

US patent No. 4,410,175 A teaches a safety suspension unit with a tracking carriage connectable to an elevated fixed track, the suspension unit having a spring loaded pulley system with a support cable connected to a harness for aiding a skater, in the learning and practicing of jumps and spins. The tension in the spring which loads the pulley system is increased as the support cable is dispensed.

US patent No. 5,221,241 A teaches a gymnastic training device has a conventional training belt adapted to support a gymnast at the waist. A pair of elongated resilient supporting assemblies is attached to opposite sides of the training belt and are comprised of bungy cords which can be selectively added or removed with respect to the assemblies to adjust the resilient capabilities thereof. A pulley support means including a pair of laterally positioned pulleys and at least one elevated pulley are supported over the normal position of the training belt by either a self-standing frame or by a frame assembly attached to the ceiling of a building. A first cable has a center portion and opposite ends with the opposite ends being secured to each of the free ends of the elongated resilient supporting assemblies. The first cable has its center portion threaded over the laterally positioned pulleys and the elevated pulley whereby the training belt is centrally supported between and below the laterally positioned pulleys and above a generally horizontal gymnastic surface. A loop is formed in the first cable and extends downwardly below one of the laterally positioned cables. The loop has a pulley thereon which is secured to the upper end of a second cable which has its lower end secured to an anchored crank mechanism whereby the operation of

the crank mechanism can adjust the length of the first cable and thereby adjust the effective height of the training belt.

US patent application No. 2007/0287599 A1 discloses an athletic trainer has a spotting apparatus received by a support frame. A pair of connected, spaced-apart lateral supports define the support frame and provide a pair of pivotal support surfaces that together provide a first axis of rotation, about which the spotting apparatus may selectively rotate. The spotting apparatus may consist of connected front and back braces with a ledge seat attached to the back brace for support and comfort. Alternatively, the spotting apparatus may be a unitary, substantially circular brace having an internal bearing raceway and attached support webbing that permit rotation about a second axis.

US Patent No. 3,432,163 A teaches a twisting and tumbling belt and more particularly an improvement in such belt of means preventing relative movement between a waist-encompassing belt track and connecting means for connecting said belt track to an elevated support without restricting rotation of said connecting means around said belt track.

US patent No. 4,449,716 A teaches a device for training athletes in gymnastics, acrobatics and the like comprising a spotting rig wherein the slack in the gymnast's suspension lines is automatically removed by a take-up mechanism. In a preferred form, the take-up mechanism includes a pair of connected swinging arms having sheaves at their free end. The arms are spring loaded so as to urge their ends away from each other, and the suspension line slack is accumulated between the sheaves. A brake mechanism is provided to slow or stop the motion of the arms and thereby retard or arrest the downward movement of the gymnast.

US patent No. 5,178,590 A teaches an aerial exercise assembly is provided which enables human users to achieve bounding, swinging and flipping exercise movements and comprises a set of swing members such as straps that extend downwardly from a support and which may be coupled to a single strap or rope for hoisting the user to a desired exercise position. The description states that a pair of elongate elastic members having multiple elastic strands establish elastic connection between the swing members and a pair of support straps. It is also stated that the extension of the elastic members is limited by safety cables to limit downward movement of the support straps to enhance the safety of the apparatus. The description mentions foot engaging elements, which may be loops or one or more foot boards, are provided at the lower ends of the support straps for stabilized engagement with the feet of the user. A

pelvic harness is positionable about the pelvic region of the user and is provided with a pair of harness pivot straps that enable lateral positioning and 360° pivoting of the harness and the user relative to the support straps so that the user can accomplish flips while exercising and can accomplish bounding at both the upright and inverted positions. The harness pivot straps further enable the user to accomplish a substantially seated position such as for resting between periods of exercise.

US patent No. 5,662,555 A teaches a family, portable power stretching and entire body building gym, and method of using the same, comprising hooks (2) for suspending the device from a rod or beam (4), first elongate flexible members (8) secured at a first end thereof to the hooks (2), stirrups (10) secured at a second end of the first elongate flexible members (8), second elongate flexible members (12) secured at one end to the hooks (2), a plurality of connectors (14) spaced along the second elongate flexible members (12), and hand grips (16) removable attached to the connectors (14). The gym also comprises a chin bar, slant board and knee bar inverted posture devices for being adjustably suspended from the elongate flexible members for working and stretching the entire body in an inverted position, enabling gravity to help relieve spine compression created from being in an upright position.

US patent No. 4,431,184 A teaches an aerial gymnastic exerciser having a pair of handles depending from cords threaded through compound pulley systems located between upper and lower supports with a body harness depending from the lower support. Increase or decrease in resistance to operation of the exerciser by an operator suspended in the harness and pulling on the handles is achieved by a plurality of removable weights depending from one end of cords passing upward and over part of the pulley systems and back downward with the other ends secured to the handles. Other modifications for resistance can be by either removable weights secured to the lower support, or by removable clothespin type springs with respective ends of each removably secured to the upper and lower supports or by use of both the removable weights and springs. It is stated that resistance can also be adjusted by how much the pulley systems are compounded.

US patent no. 5,330,398 A teaches gallows for rings, intended to be used in sport gymnastics, wherein the cross beam is more flexible than conventionally known models. The cross beam is hinged to the uprights of the gallows with a silentblock or rubber piece. The rings of the gallows are connected to the cross beam using rigid rods made of a composite material or other rigid material, with the rigid rods being connected at their tops by a self-locking trunnion provided with a universal joint and fixed to the rings by a short link of textile material.

Despite the numerous devices found in the prior art, there still exists a need for a portable suspension rig adapted for use in small spaces which allow for the practice of aerial exercise in a safe environment and preferably without the need for an individual acting as a "spotter".

SUMMARY OF THE INVENTION

According to a first aspect of the present invention, there is provided a suspension rig for use in aerial acrobatics, said rig comprising:

- at least three main vertical supports, each one of the at least three main vertical supports comprising:

- a top extremity; and

- a bottom extremity,

said bottom extremity being adapted to rest on a surface and arranged equidistant from one another and said each one of said top extremity meeting the top extremity of the other main vertical supports at an apex; and

- means for suspending an individual; said means for suspending an individual being connected to said suspension rig underneath the apex.

Preferably, each one of the at least three main vertical supports have an identical arcuate shape. More preferably, each one of the at least three main vertical supports have an identical biarcuate shape.

According to a preferred embodiment of the present invention, each one of the at least three main vertical supports are connected to a restraining means at their bottom extremity. Preferably, the restraining means comprise a wire connecting each one of the main vertical supports to one another.

According to a preferred embodiment, the restraining means comprise at least one wire attached to each one of the vertical supports and each one of at least one wire are attached together under at a centerpoint under the suspension rig. Preferably, each one of the vertical supports comprises a restraining means comprising a wire having a first extremity attached to the bottom extremity of the vertical supports and having a second extremity attached to the second extremity of the wires from the other vertical supports.

Preferably, the centerpoint is on the surface on which the bottom section of each one of the vertical supports is positioned

According to another preferred embodiment, the restraining means comprise at least one wire going around a perimeter defined by the bottom section of the main vertical support and attached to each one of the main vertical supports through a securing means.

Preferably, the securing means is selected from the group consisting of: a hook; a ring; a loop; and a combination thereof.

Preferably, the means for suspending an individual comprise a means for attaching a harness for a user selected from the group consisting of: a hook; a ring; and a loop.

According to a preferred embodiment of the present invention, the apex comprises a three-prong centerpiece in which the top extremity of each main vertical support member is fixedly inserted.

According to a preferred embodiment of the present invention, the suspension rig can be used in a home setting or more preferably outdoors without the use of a spotter to supervise one's routine, hence providing substantial independence to the user of the suspension rig.

BRIEF DESCRIPTION OF THE FIGURES

The invention may be more completely understood in consideration of the following description of various embodiments of the invention in connection with the accompanying figures, in which:

Figure 1 is a perspective view of the suspension rig according to a preferred embodiment of the present invention;

Figure 2 is a perspective view of the suspension rig according to a preferred embodiment of the present invention;

Figure 3 is a close up perspective view of the apex of the suspension rig according to a preferred embodiment of the present invention;

Figure 4 is a close up view of a securing means on a vertical support of the suspension rig according to a preferred embodiment of the present invention;

Figure 5 is a close up view of the attachment of the band to a vertical support member according to a preferred embodiment of the present invention; and

Figure 6 is a side view of a vertical support member according to a preferred embodiment of the present invention.

DESCRIPTION OF AN EMBODIMENT OF THE INVENTION

Figures 1 and 2 depict a suspension rig according to a preferred embodiment of the present invention. The suspension rig is adapted to keep an individual above the ground in a harness which allows rotation along at least two axes. The suspension rig having three main vertical supports arranged equidistant from one another meeting each other at an apex, from which a ring is attached. According to a preferred embodiment, one can hang a harness from the ring or a piece of fabric adapted to have an individual hang therefrom. This arrangement allows a user to perform acrobatic maneuvers safely without the presence of a person "spotting" him or her.

Illustrated in **Figure 1** is a perspective view of the suspension rig according to a preferred embodiment of the present invention. The main vertical support members (10, 20, 30) are joined together at the apex (5) of the rig (1). The main vertical support members can be made out of various materials having high resiliency. According to a preferred embodiment of the present invention, the supports are made of steel commonly used in exercise equipment. However, the supports could also be made of carbon fiber, aluminum, plastic, wood, or any other material suitable to withstand the weight/support requirements as requested by the manufacturer. The point of conversion of the three vertical supports also referred to as the apex preferably comprises of a three-prong centerpiece in which the top extremity of each support member is inserted. Each one of the support members remain inserted in the centerpiece by securing means. Said securing means (41) can be selected from the group consisting of: pressure pins; nuts and bolts or similar physical means of securing the support member to the centerpiece.

According to a preferred embodiment of the present invention, the centerpiece comprises an anchor point (11) to which a chain; rubber band; wire or a loop can be attached. In Figure 1, a short chain (13) is present. Preferably, the anchor point support a short chain to which is attached a loop (15) adapted to receive an aerial silk fabric. Aerial silk fabrics are used in aerial silk acrobatics and are well known to be sufficiently resilient to support the weight of an individual and in some instances, two individuals,

when such individual is performing acrobatics supported by the suspension according to a preferred embodiment of the present invention.

According to a preferred embodiment of the present invention, the vertical support members (10, 20 and 30) can be comprised of more than one piece to make them easier to be transported. In referring to Figure 4, when the vertical support members are made of more than a single piece they can be assembled using a simple method of insertion of male ends (21) into female ends (23) and kept in place by the use of securing means (41) such as pressure pins, for example. At their bottom extremity each one of the vertical support members can preferably have a loop (25) or equivalent physical member adapted to receive a hook or carabiner attached to a band stretching (27) to the other support members. The presence of this band is preferable as it can provide stability between the support members and prevents the spreading of the support members away from one another when in use, thereby avoiding a potential collapse of the suspension rig. Preferably, the band is made of a non-stretchable material which, when installed properly will not yield or very little when pressure is applied by the use of the suspension rig. According to a preferred embodiment of the present invention, the supports (10, 20 and 30) have a biarcuate shape. This biarcuate shaped is emphasized by the presence of elbows (17 and 19) in the vertical support members. Preferably, the vertical support members further comprise a strengthening brace (29) located where the support members form an arc. This is to provide the necessary to the supporting members especially when considering that users may weigh more than what is the average normal weight. Preferably the strengthening brace (29) is located on the inside of the arc located on the support member. According to a preferred embodiment, the strengthening brace (29) is found only on the arc/elbow (19) located on the upper section (33) of the support member. According to another preferred embodiment, the strengthening brace can be found only on the lower arc (31) of the support member. According to a preferred embodiment, the strengthening brace can be found on both arcs of the support member.

Figure 2 is a perspective view of the suspension rig according to a preferred embodiment of the present invention. **Figure 3** is a close up perspective view of the apex (5) of the suspension rig (1) according to a preferred embodiment of the present invention. **Figure 4** is a close up view of a securing means (41) on a vertical support (10) of the suspension rig (1) according to a preferred embodiment of the present invention. **Figure 5** is a close up view of the attachment of the band (27) to a vertical support member (10) via a loop (25) secured on the support member (10). **Figure 6** is a side view of a vertical support member according to a preferred embodiment of the present invention.

According to a preferred embodiment of the present invention, an individual can use a harness which preferably comprises a belt to put around a user's waist and two belts to attach around the upper portion of each of the user's thighs. This is referred to as a pelvic harness. The harness further comprises a means for attachment to the suspension rig, preferably a ring or a carabiner securely attached to the back portion of the user's harness. Such a harness can permit an individual to accomplish flips while exercising as well as a variety of other exercises all the while being off the ground and without a spotter.

According to a preferred embodiment of the present invention, the means for attaching a harness comprises a hook; a loop; or a ring. Also according to another preferred embodiment, the means for attaching a harness may further comprise a spring to soften the movement by a user. Examples of possible springs that could be considered include, but are not limited to: drawbar springs; single full loop over center springs and double loops over center springs.

It is understood that various modifications to the above invention can be made and still be within the described invention. Such variations include but are not limited to a frame composed of two half-circles rather than a tripod as per the preferred embodiment described hereinabove. As well, one could consider designing a similar apparatus where the vertical support members form a "box" and where the rig is suspended by a resilient material adapted to provide such support at or near a centerpoint of the "box". The box can be made out of three, four, five or more vertical support members which do not meet each other at an apex but where the suspension rig comprises a device to suspend a user at or near a centerpoint of the box.

While the foregoing invention has been described in some detail for purposes of clarity and understanding, it will be appreciated by those skilled in the relevant arts, once they have been made familiar with this disclosure that various changes in form and detail can be made without departing from the true scope of the invention in the appended claims.

CLAIMS

1. A suspension rig for use in aerial acrobatics, said rig comprising:
 - at least three main vertical supports, each one of the at least three main vertical supports comprising:
 - a top extremity; and
 - a bottom extremity,said bottom extremity being adapted to rest on a surface and arranged equidistant from one another and said each one of said top extremity meeting the top extremity of the other main vertical supports at an apex; and
 - means for suspending an individual; said means for suspending an individual being connected to said suspension rig underneath the apex.
2. The suspension rig according to claim 1 wherein each one of the at least three main vertical supports have an identical arcuate shape.
3. The suspension rig according to claim 1 wherein each one of the at least three main vertical supports have an identical biarcuate shape.
4. The suspension rig according to any one of claims 1 to 3 wherein each one of the at least three main vertical supports are connected to a restraining means at their bottom extremity.
5. The suspension rig according to claim 4 wherein the restraining means comprise a wire connecting each one of the main vertical supports to one another.
6. The suspension rig according to claim 4 wherein the restraining means comprise at least one wire attached to each one of the vertical supports and each one of at least one wire are attached together under at a centerpoint under the suspension rig.
7. The suspension rig according to claim 4 wherein each one of the vertical supports comprises a restraining means comprising a wire having a first extremity attached to the bottom extremity of the vertical supports and having a second extremity attached to the second extremity of the wires from the other vertical supports.

8. The suspension rig according to claim 6 wherein the centerpoint is on the surface on which the bottom section of each one of the vertical supports is positioned
9. The suspension rig according to claim 7 wherein the restraining means comprise at least one wire going around a perimeter defined by the bottom section of the main vertical support and attached to each one of the main vertical supports through a securing means.
10. The suspension rig according to claim 7 wherein the securing means is selected from the group consisting of: a hook; a ring; a loop; and a combination thereof.
11. The suspension rig according to any one of claims 1 to 10 wherein the means for suspending an individual comprise a means for attaching a harness for a user selected from the group consisting of: a hook; a ring; and a loop.
12. The suspension rig according to any one of claims 1 to 11 wherein the apex comprises a three-prong centerpiece in which the top extremity of each main vertical support member is fixedly inserted.

FIGURES

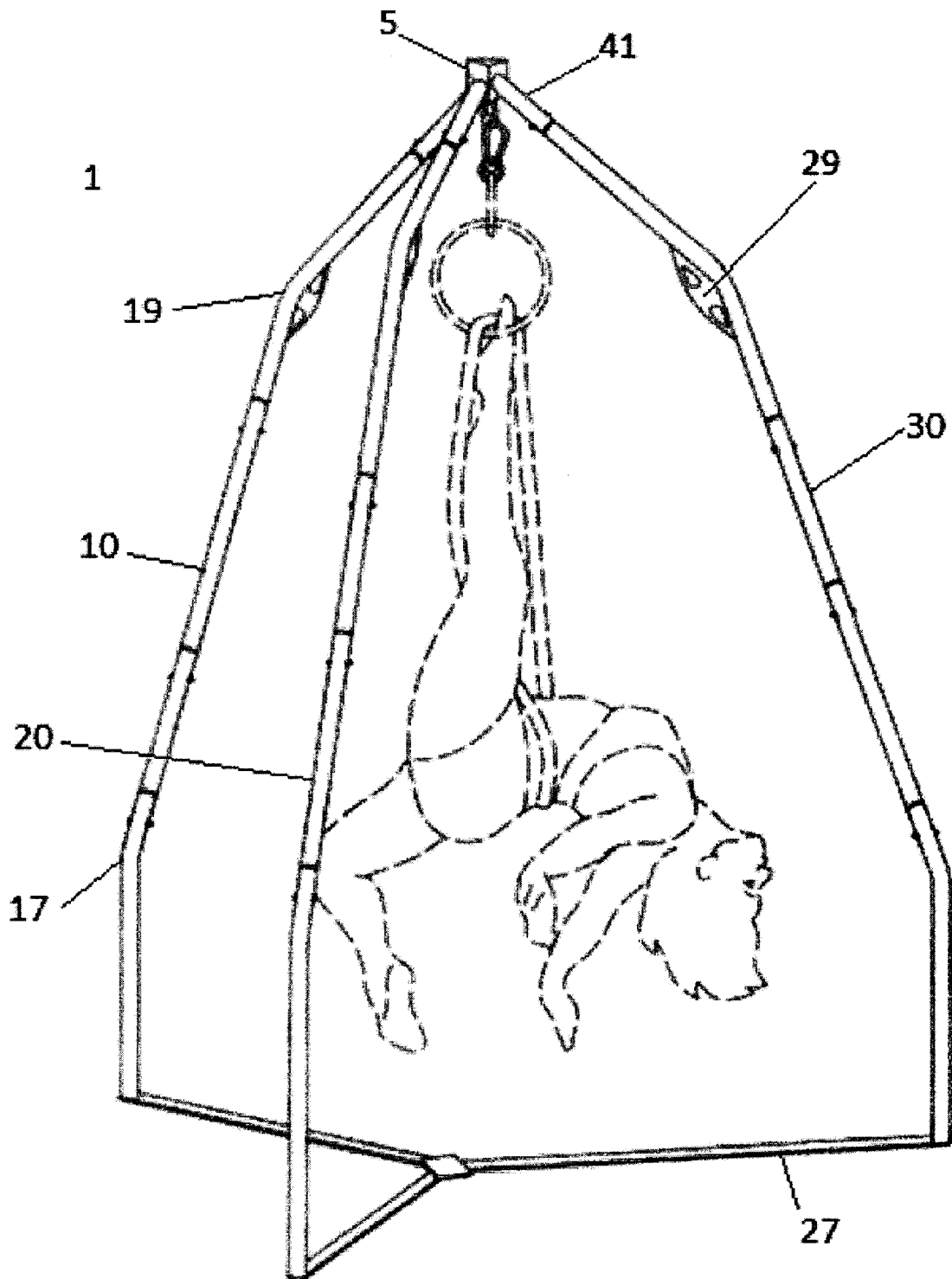

FIG. 1

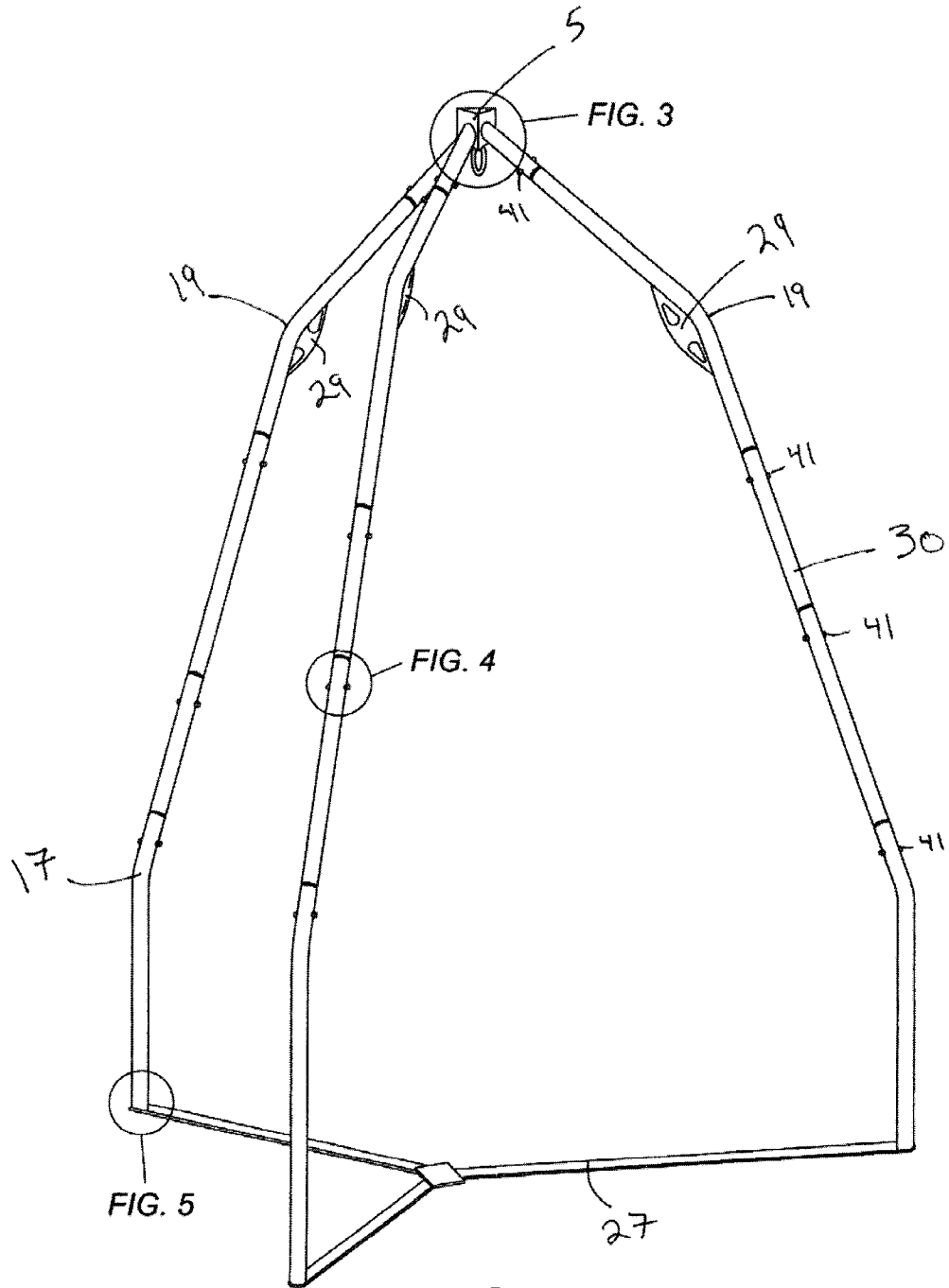

FIG. 2

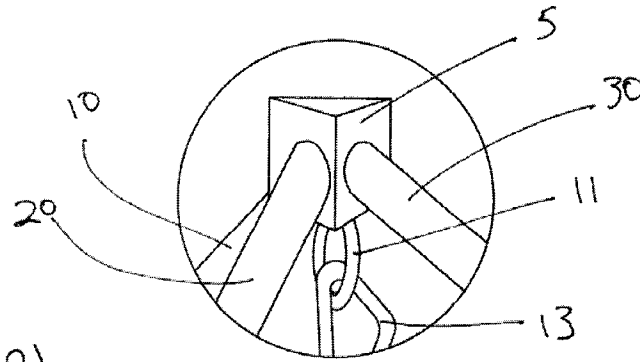

FIG. 3

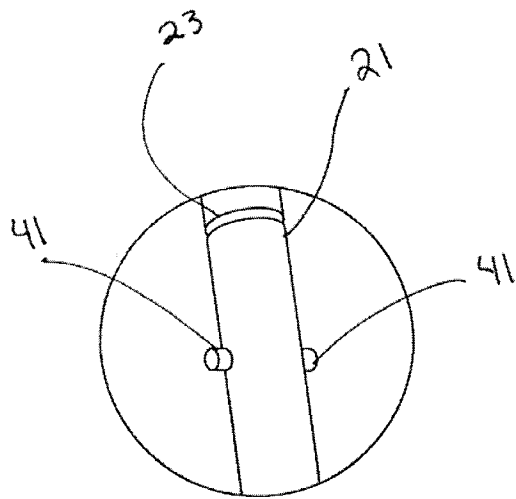

FIG. 4

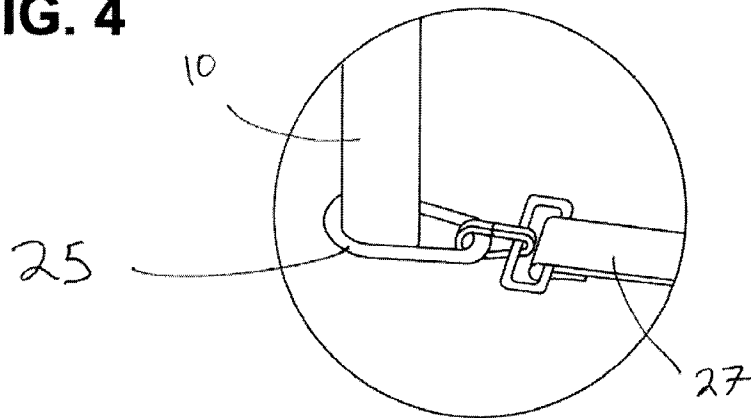

FIG. 5

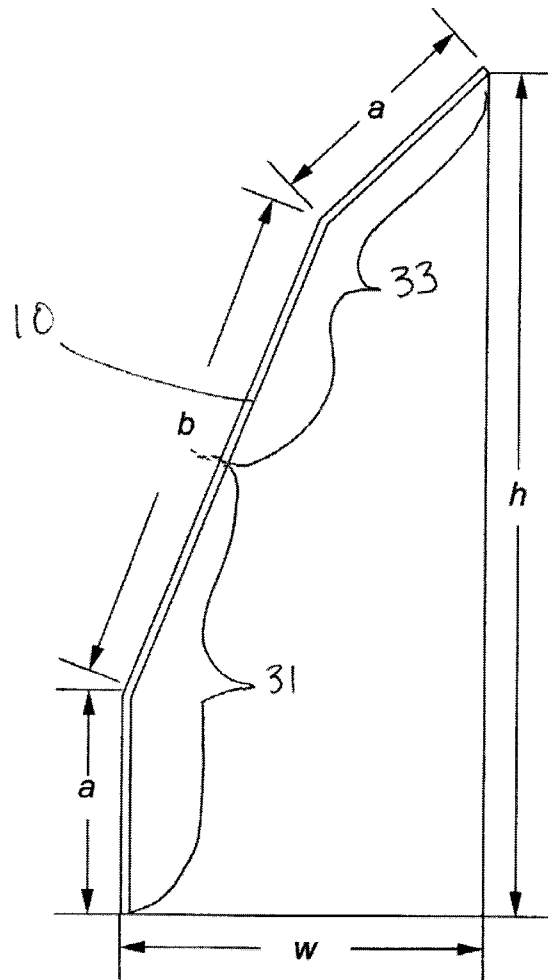

FIG. 6

INTERNATIONAL SEARCH REPORT

International application No.

PCT/CA2018/000165

A. CLASSIFICATION OF SUBJECT MATTER

IPC: *A63B 7/00* (2006.01), *A63B 22/00* (2006.01), *A63B 69/00* (2006.01), *A63J 7/00* (2006.01)

According to International Patent Classification (IPC) or to both national classification and IPC

B. FIELDS SEARCHED

Minimum documentation searched (classification system followed by classification symbols)

IPC: *A63B* (2006.01), *A63B 7/00* (2006.01), *A63B 22/00* (2006.01), *A63B 69/00* (2006.01), *A63J 7/00* (2006.01)

Documentation searched other than minimum documentation to the extent that such documents are included in the fields searched

Electronic database(s) consulted during the international search (name of database(s) and, where practicable, search terms used)

Questel-Orbit, Canadian Patent Database, Google Patent Advance:

Classification/Keywords: suspension, rig, hanging, support, acrobat, restrain

C. DOCUMENTS CONSIDERED TO BE RELEVANT

Category*	Citation of document, with indication, where appropriate, of the relevant passages	Relevant to claim No.
X Y	US7255666 (CARDENAS) 14-August-2007 (14-08-2007) Figure 1, entire document	1-4, 11-12 5-10
X	US6929478 (SPENCER et al.) 16-August-2005 (16-08-2005) Figure 1	1-3
Y	US8425383 (KELLY) 23-April-2013 (23-04-2013) Figure 3	5-10
A	US6554747 (REMPE) 29-April-2003 (29-04-2003) Entire document	1
A	US5577984 (BARE) 26-November-1996 (26-11-1996) Entire document	1

 Further documents are listed in the continuation of Box C. See patent family annex.

* "A" "E" "L" "O" "P"	Special categories of cited documents: document defining the general state of the art which is not considered to be of particular relevance earlier application or patent but published on or after the international filing date document which may throw doubts on priority claim(s) or which is cited to establish the publication date of another citation or other special reason (as specified) document referring to an oral disclosure, use, exhibition or other means document published prior to the international filing date but later than the priority date claimed	"T" "X" "Y" "&"	later document published after the international filing date or priority date and not in conflict with the application but cited to understand the principle or theory underlying the invention document of particular relevance; the claimed invention cannot be considered novel or cannot be considered to involve an inventive step when the document is taken alone document of particular relevance; the claimed invention cannot be considered to involve an inventive step when the document is combined with one or more other such documents, such combination being obvious to a person skilled in the art document member of the same patent family
--------------------------------------	--	--------------------------	--

Date of the actual completion of the international search
28 September 2018 (28-09-2018)Date of mailing of the international search report
01 October 2018 (01-10-2018)Name and mailing address of the ISA/CA
Canadian Intellectual Property Office
Place du Portage I, C114 - 1st Floor, Box PCT
50 Victoria Street
Gatineau, Quebec K1A 0C9
Facsimile No.: 819-953-2476

Authorized officer

Hoan Huynh (819) 639-7857

INTERNATIONAL SEARCH REPORT
Information on patent family members

International application No.
PCT/CA2018/000165

Patent Document Cited in Search Report	Publication Date	Patent Family Member(s)	Publication Date
US7255666B2	14 August 2007 (14-08-2007)	US2006052222A1 US7255666B2	09 March 2006 (09-03-2006) 14 August 2007 (14-08-2007)
US6929478B1	16 August 2005 (16-08-2005)	None	
US8425383B1	23 April 2013 (23-04-2013)	US8425383B1 US9352179B1	23 April 2013 (23-04-2013) 31 May 2016 (31-05-2016)
US6554747B1	29 April 2003 (29-04-2003)	None	
US5577984A	26 November 1996 (26-11-1996)	None	