



(51) International Patent Classification:
H04R 25/00 (2006.01)

(21) International Application Number:
PCT/US2011/027902

(22) International Filing Date:
10 March 2011 (10.03.2011)

(25) Filing Language: English

(26) Publication Language: English

(71) Applicant (for all designated States except US):
SIEMENS HEARING INSTRUMENTS, INC. [US/US];
10 Constitution Avenue, Piscataway, New Jersey 08854-6155 (US).

(72) Inventors; and

(75) Inventors/Applicants (for US only): **DE FINIS, James Edward** [US/US]; 96 River Road, Flanders, New Jersey 07836 (US). **FAIELLA, Edmund J.** [US/US]; 6 Pecan Valley Drive, Marlboro, New Jersey 07746 (US).

(74) Agents: **MONTGOMERY, Francis G.** et al.; Siemens Corporation- Intellectual Property Dept., 170 Wood Avenue South, Iselin, New Jersey 08830 (US).

(81) Designated States (unless otherwise indicated, for every kind of national protection available): AE, AG, AL, AM, AO, AT, AU, AZ, BA, BB, BG, BH, BR, BW, BY, BZ, CA, CH, CL, CN, CO, CR, CU, CZ, DE, DK, DM, DO, DZ, EC, EE, EG, ES, FI, GB, GD, GE, GH, GM, GT, HN, HR, HU, ID, IL, IN, IS, JP, KE, KG, KM, KN, KP, KR, KZ, LA, LC, LK, LR, LS, LT, LU, LY, MA, MD, ME, MG, MK, MN, MW, MX, MY, MZ, NA, NG, NI, NO, NZ, OM, PE, PG, PH, PL, PT, RO, RS, RU, SC, SD, SE, SG, SK, SL, SM, ST, SV, SY, TH, TJ, TM, TN, TR, TT, TZ, UA, UG, US, UZ, VC, VN, ZA, ZM, ZW.

(84) Designated States (unless otherwise indicated, for every kind of regional protection available): ARIPO (BW, GH, GM, KE, LR, LS, MW, MZ, NA, SD, SL, SZ, TZ, UG, ZM, ZW), Eurasian (AM, AZ, BY, KG, KZ, MD, RU, TJ, TM), European (AL, AT, BE, BG, CH, CY, CZ, DE, DK, EE, ES, FI, FR, GB, GR, HR, HU, IE, IS, IT, LT, LU, LV, MC, MK, MT, NL, NO, PL, PT, RO, RS, SE, SI, SK, SM, TR), OAPI (BF, BJ, CF, CG, CI, CM, GA, GN, GQ, GW, ML, MR, NE, SN, TD, TG).

Published:

— with international search report (Art. 21(3))

(54) Title: WAX-RESISTANT DOME FOR A HEARING INSTRUMENT

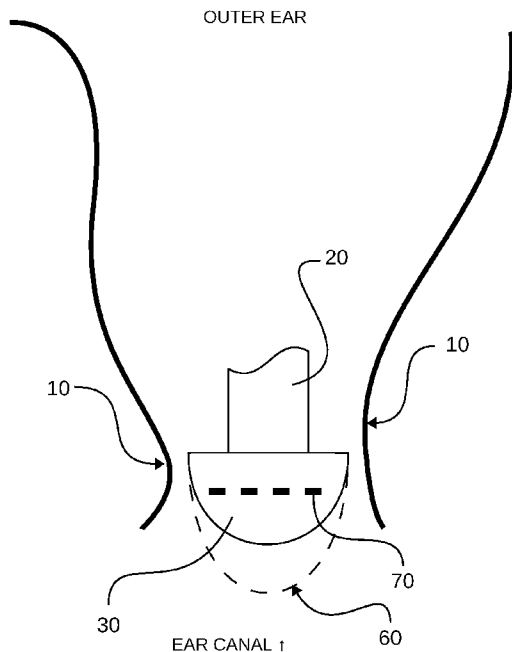

Fig. 1

(57) Abstract: The opening in a receiver tube may be shielded from cerumen by placing the end of the receiver tube in a dome comprising vents that allow the sound to pass. The dome and the vents may assume a variety of shapes.

WO 2012/121730 A1

Wax-Resistant Dome for a Hearing Instrument

Technical Field

Hearing instruments and hearing instrument components.

5

Background Art per PCT Rule 5.1(a)(ii)

Siemens CENTRA active (brochure), June 2008, 12 pp, available at: http://hearing.siemens.com/_resources-re/files/04-products/13-centra-active/_resources/pdf/CentraActive_information-brochure.pdf.

10

Disclosure of Invention

(Per PCT Rule 5.1(b), see Best Mode for Carrying out the Invention, below.)

15

Brief Description of Drawings

Fig. 1 is a drawing of a wax-resistant dome positioned in an ear canal;

Figs. 2 and 3 are perspective and cross-sectional views, respectively, of a wax-resistant dome;

20

Figs. 4 and 5 are cross-sectional elevation and bottom views, respectively, of a receiver tube retainer;

Figs. 6 and 7 are cross-sectional elevation views of a wax-resistant dome employing alternative configurations of the receiver tube retainer;

25

Figs. 8 and 9 are perspective views of a wax-resistant dome with elliptical and curved vents; and

Figs. 10 and 11 are drawings of a wax-resistant dome incorporated into the shell of a hearing instrument.

- 2 -

Best Mode for Carrying out the Invention

An ear canal comprising ear canal walls 10 is shown in Fig. 1. As illustrated here, a hearing instrument receiver tube 20 is attached to a wax-resistant dome 30 positioned in the ear canal. The wax-resistant dome 30, shown again in Fig. 2, comprises a hollow dome shell 32 having a partial spherical outer surface 34. The outer surface 34 may assume a variety of shapes, including a partial sphere, an ellipsoid such as a partial oblate or prolate spheroid (see the dashed line 60 in Fig. 1), or any other shape, including irregular two-dimensional surfaces, suitable for the hearing application and the user's ear canal.

The wax-resistant dome 30 has sound vents 70 distributed over the outer surface 34 of the dome 30. The sound vents 70 allow sound exiting from the receiver tube 20 to pass into the ear canal and also equalize the air pressure on either side of the dome 30. The sound vents 70 in Fig. 2 are positioned approximately midway between the top 36 and the bottom 38 of the dome 30, but may be located higher or lower on the dome 30.

A cross-sectional view of the wax-resistant dome 30, illustrating the dome shell wall 40 and the hollow, interior volume 42, is shown in Fig. 3. Note that the receiver tube 20 is not shown as a cross section in this figure. The dome shell wall 40 may be fabricated from a soft material for user comfort.

The receiver tube 20 is held vertically within the dome 30 (note the vertical axis 44) by a receiver tube retainer 100 comprising a sound-impervious horizontal member 102 and a receptacle such as a vertically-oriented sleeve 110 that releasably accepts the end 22 of the receiver tube 20. The retainer 100 may be held in place within

- 3 -

the dome 30 by any suitable method, e.g., a detent, recess, an annulus, or nubs 46 on the inside surface 48 of the dome shell wall 40 that receive the horizontal member 102. A suitable glue or epoxy may also be employed. As shown in Fig. 3, the receiver tube retainer 100 is
5 positioned below the sound vents 70 in the lower half 50 of the dome 30.

The retainer 100, also shown separately in the cross-sectional elevation view of Fig. 4 and the bottom view of Fig. 5, comprises an outer perimeter 104 that conforms to the dimensions of the inside surface 48 of the dome 30. In the bottom view of Fig. 5, the outer perimeter 104 is
10 circular, but may also be elliptical or any other suitable shape matching the corresponding shape of the inside surface 48 of the dome shell 32.

The top end 112 of the vertically-oriented sleeve 110 comprises a partial closure 114 having an opening 116 aligned with and adjacent to the opening 24 in the end 22 of the receiver tube 20. For purposes of
15 illustration, the horizontal member 102, the sleeve 110, and the partial closure 114 of the retainer 100 are shown with a cross-hatch in the bottom view in Fig. 5 to visually distinguish the various elements in the figure. If desired, the dome 30 and the retainer 100 could be
fabricated as a monolithic component.

20 In operation, sound from the hearing instrument receiver (not shown) passes through the receiver tube 20 and exits through the opening 24 in the end 22 of the receiver tube 20. From the opening 24, the sound enters the interior volume 42 of the dome 30, and passes out of the dome 30 through the sound vents 70 and into the ear canal. The
25 sound-impervious horizontal member 102 prevents the sound from exiting the dome 30 through the open dome shell bottom 38. As shown in Fig. 5, one or more pressure equalization vents 106 may be provided

- 4 -

in the horizontal member 102 to counter the occlusion effect if air cannot pass between the outer surface 34 of the dome 30 and the ear canal walls 10.

Other configurations for the receiver tube retainer are presented in Figs. 6 and 7. In Fig. 6, the receiver tube retainer 300 comprises a sound-impervious horizontal member 302 and a vertically-oriented tubular section 310 inserted through the opening 24 at the end 22 of the receiver tube 20. An alternative version of this retainer is shown in Fig. 7, which has an outer tubular section 320 encompassing the adjacent portion of the receiver tube 20. Here, the horizontal member 302 is positioned flush with the bottom 38 of the dome 30, illustrating that the horizontal member 302 may be vertically positioned at a variety of points within the lower half 50 of the dome 30, or at the very least below the sound vents 70. To further secure the attachment of the receiver tube 20 to the retainer 300, a thread 330 may be provided on the inside surface 322 of the outer tubular section 320 adjacent the receiver tube 20 or on the outside surface 312 of the vertically-oriented tubular section 310.

The sound vents 70 shown in Figs. 1-3 have a rectangular shape and lie in a plane transverse to the vertical axis 44 of the dome 30. Sound vents 170 having an elliptical shape are shown in Fig. 8 and one sound vent 270 having the shape of an "s"-curve (sound vent 270) is illustrated in Fig. 9.

The wax-resistant dome 30 may be attached to a receiver tube 20 extending from a hearing instrument receiver in a behind-the-ear or in-the-ear hearing instrument (neither shown). Should cerumen (wax)

- 5 -

enter the dome 30, the dome 30 can be cleaned by clearing the sound vents 70 and the interior volume 42 of the dome shell 32.

The dome 30 may also be used with the shell 210 of an in-the-ear or a completely-in-the-canal hearing instrument, as illustrated by the hearing instrument 200 in Fig. 10. As opposed to a dome that spans the full width of the hearing instrument shell in Fig. 10, a smaller dome could be used, as shown in Fig. 11. There, the hearing instrument 300 has a vent 310 adjacent the dome 330.

10 Industrial Applicability

The foregoing devices find industrial applicability in the field of hearing instruments.

- 6 -

What is claimed is:

1. A wax resistant dome for a hearing instrument for releasably receiving a hearing instrument receiver tube, where the receiver tube comprises an end from which sound passes, comprising:

5 a dome shell, the dome shell comprising a shell wall, a hollow interior volume, an inside surface, and a vertical axis, where the shell wall comprises a plurality of sound vents; and

a receiver tube retainer positioned within the hollow interior volume of the dome shell, the receiver tube retainer comprising a receptacle for accepting and supporting the end of the receiver
10 tube within the hollow interior volume of the dome in alignment with the vertical axis of the dome and a sound-impervious horizontal member comprising an outer perimeter conforming to the inside surface of the dome shell.

15

2. A wax resistant dome as set forth in claim 1, where the dome shell comprises a partial sphere.

3. A wax resistant dome as set forth in claim 1, where the
20 dome shell comprises a partial ellipsoid.

4. A wax resistant dome as set forth in claim 1, where the sound vent comprises a rectangular shape.

25 5. A wax resistant dome as set forth in claim 1, where the sound vent comprises an elliptical shape.

- 7 -

6. A wax resistant dome as set forth in claim 1, where the sound vent comprises an S-curved shape.

5 7. A wax resistant dome as set forth in claim 1, where the receptacle for accepting and supporting the end of the receiver tube comprises a vertical sleeve that releasably accepts the receiver tube.

10 8. A wax resistant dome as set forth in claim 1, where the receiver tube retainer comprises horizontal member comprising an circular outer perimeter.

15 9. A wax resistant dome as set forth in claim 1, where the receiver tube retainer comprises horizontal member comprising at least one vent.

20 10. A wax resistant dome as set forth in claim 1, where the hearing instrument comprises a hearing instrument shell at least partially within the ear canal, and the dome shell is affixed to the hearing instrument shell.

OUTER EAR

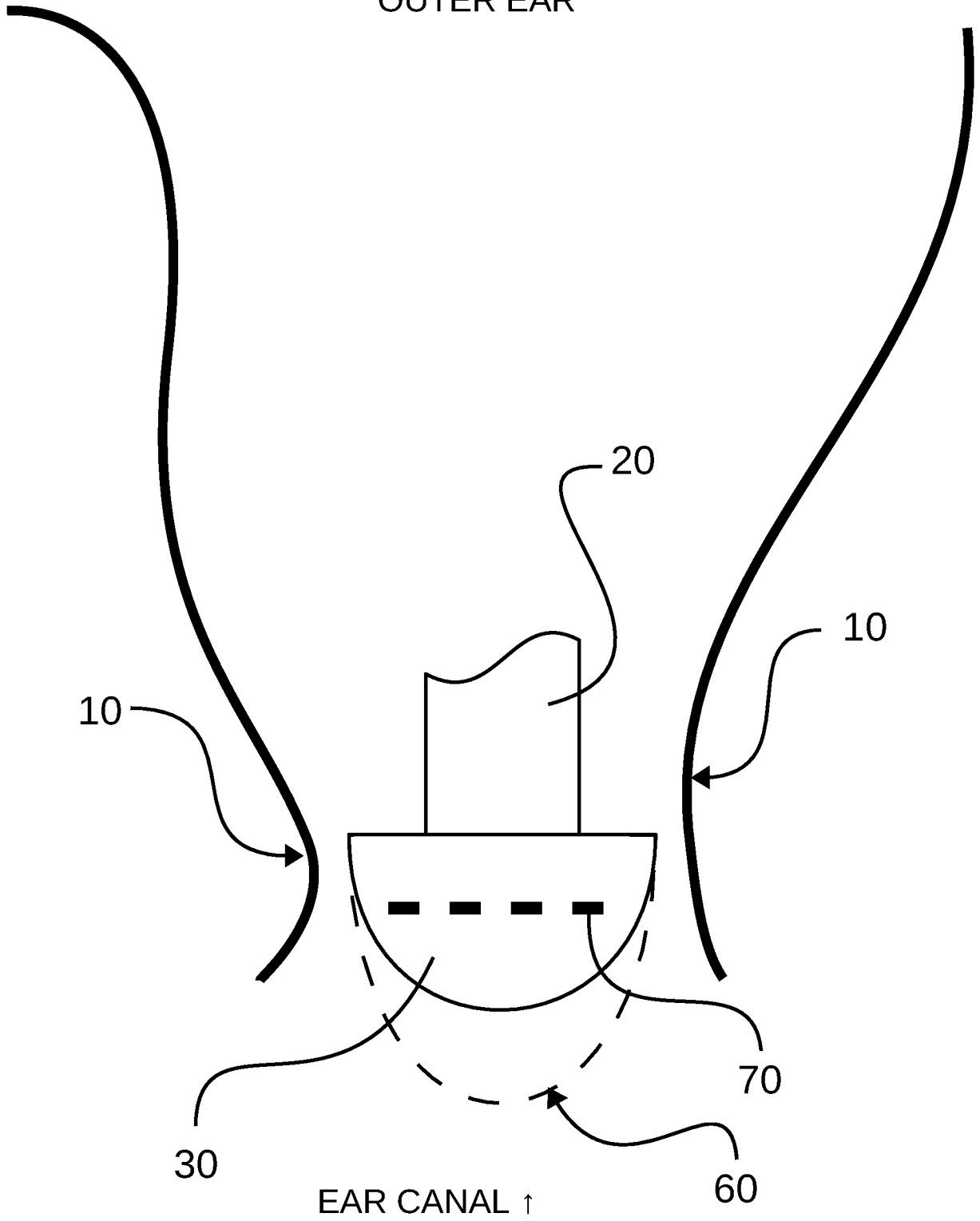

Fig. 1

2/11

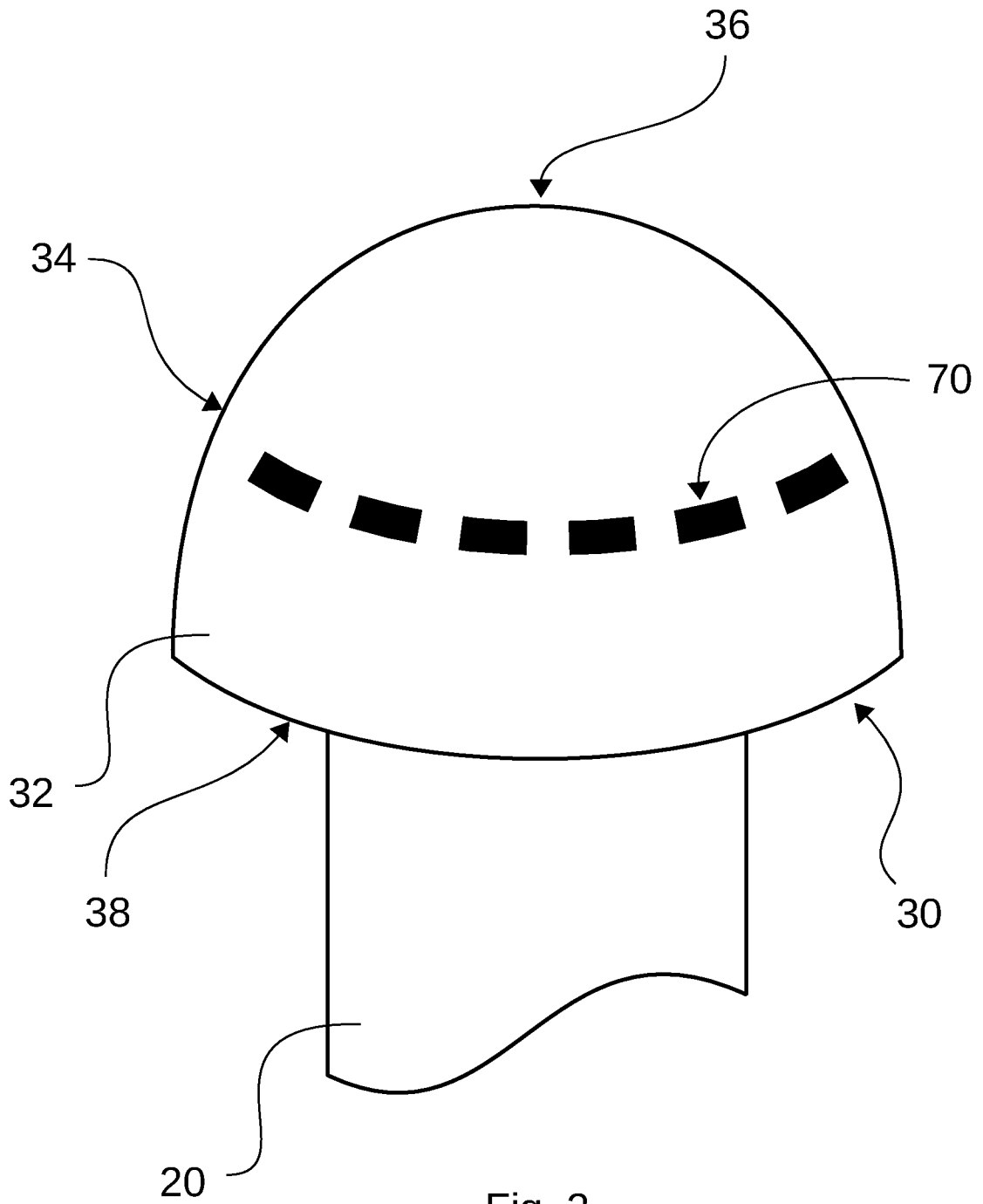

Fig. 2

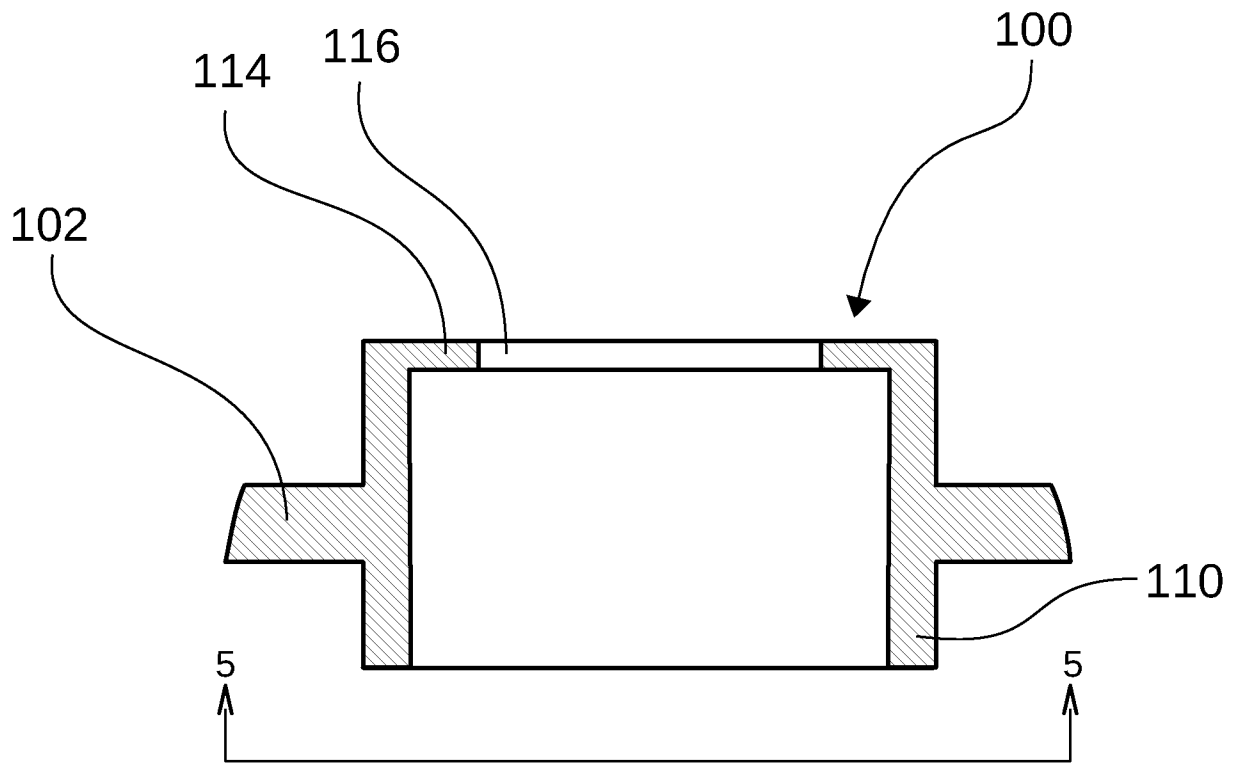

Fig. 4

5/11

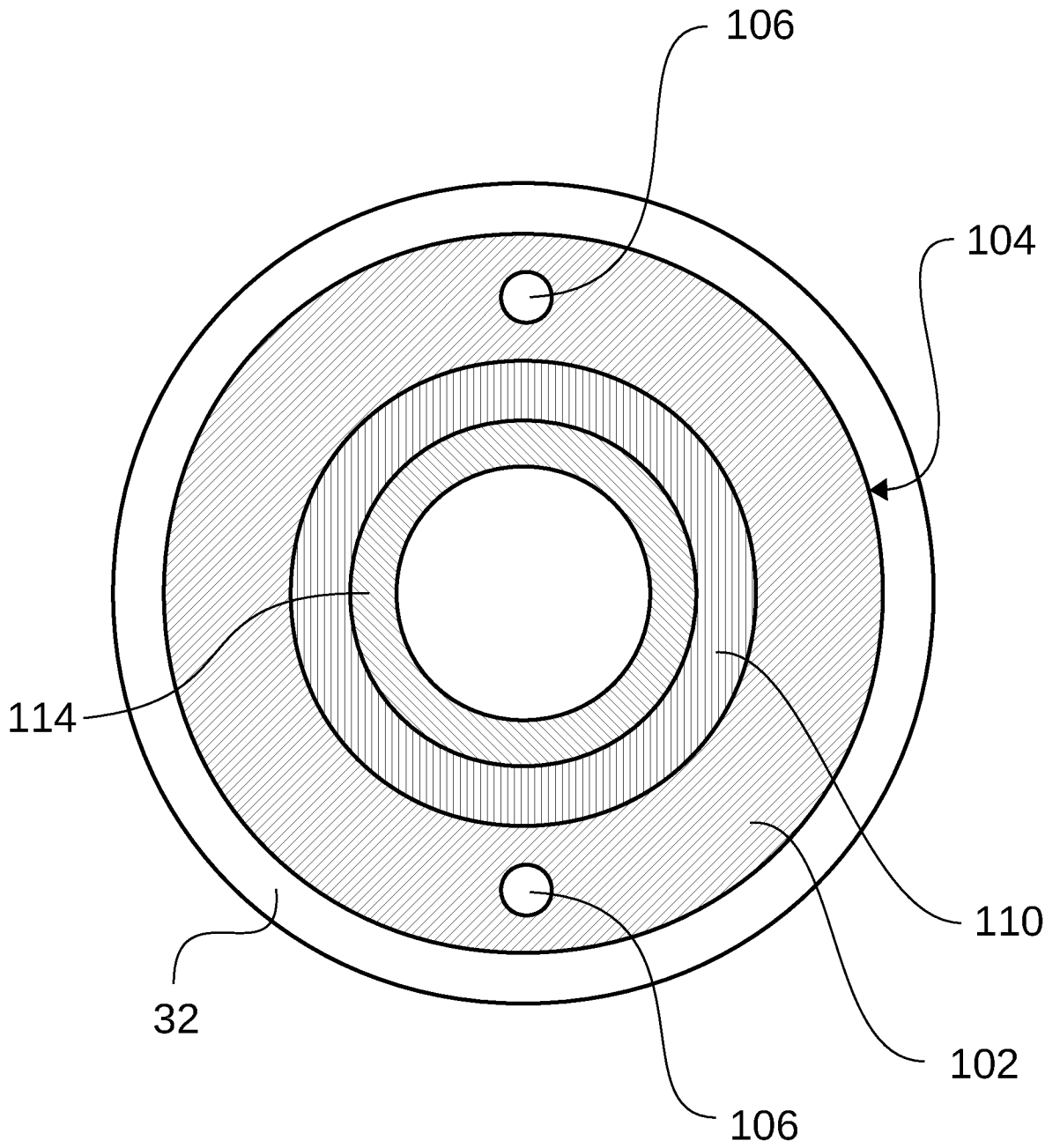

Fig. 5

7/11

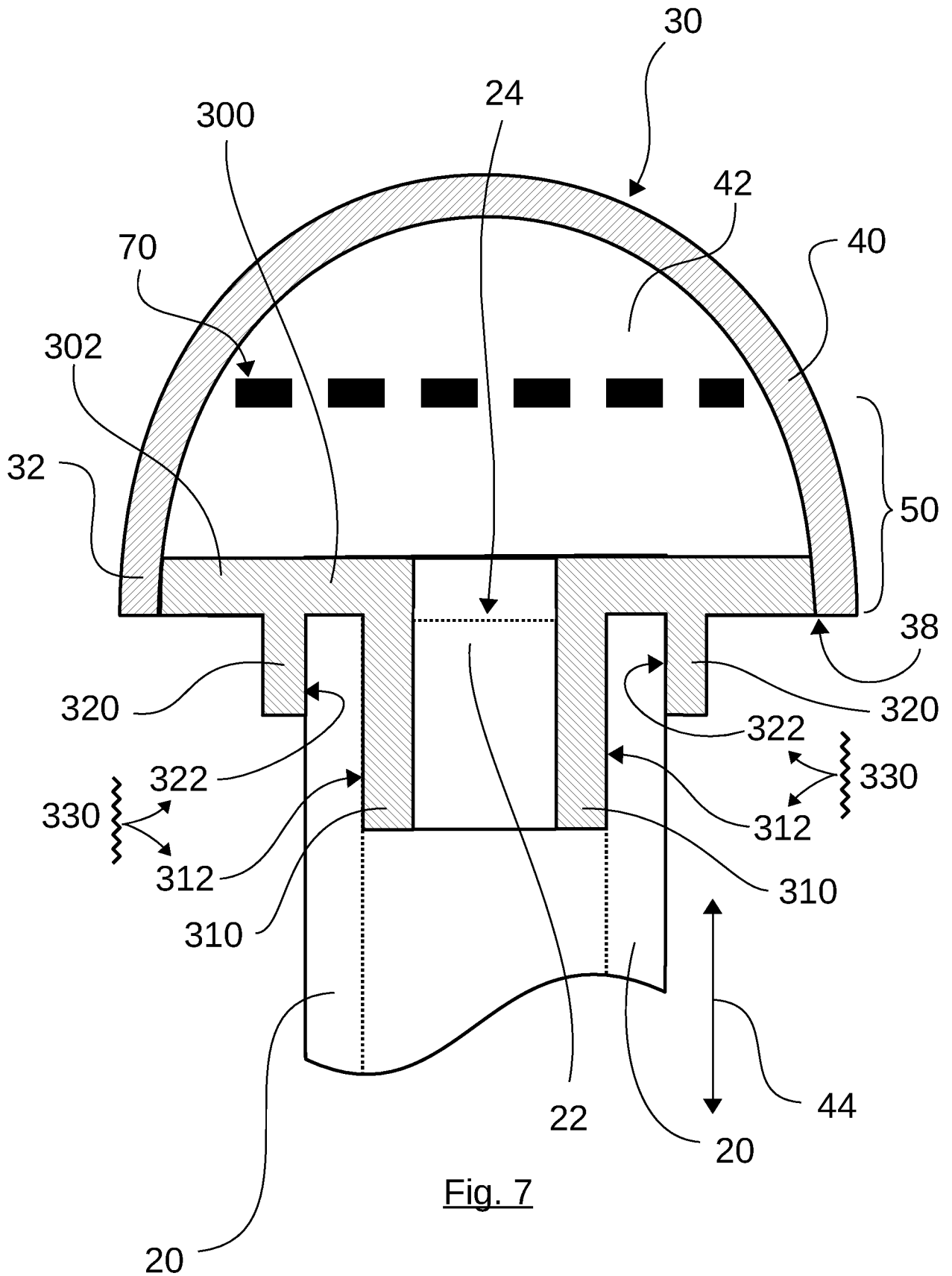

Fig. 7

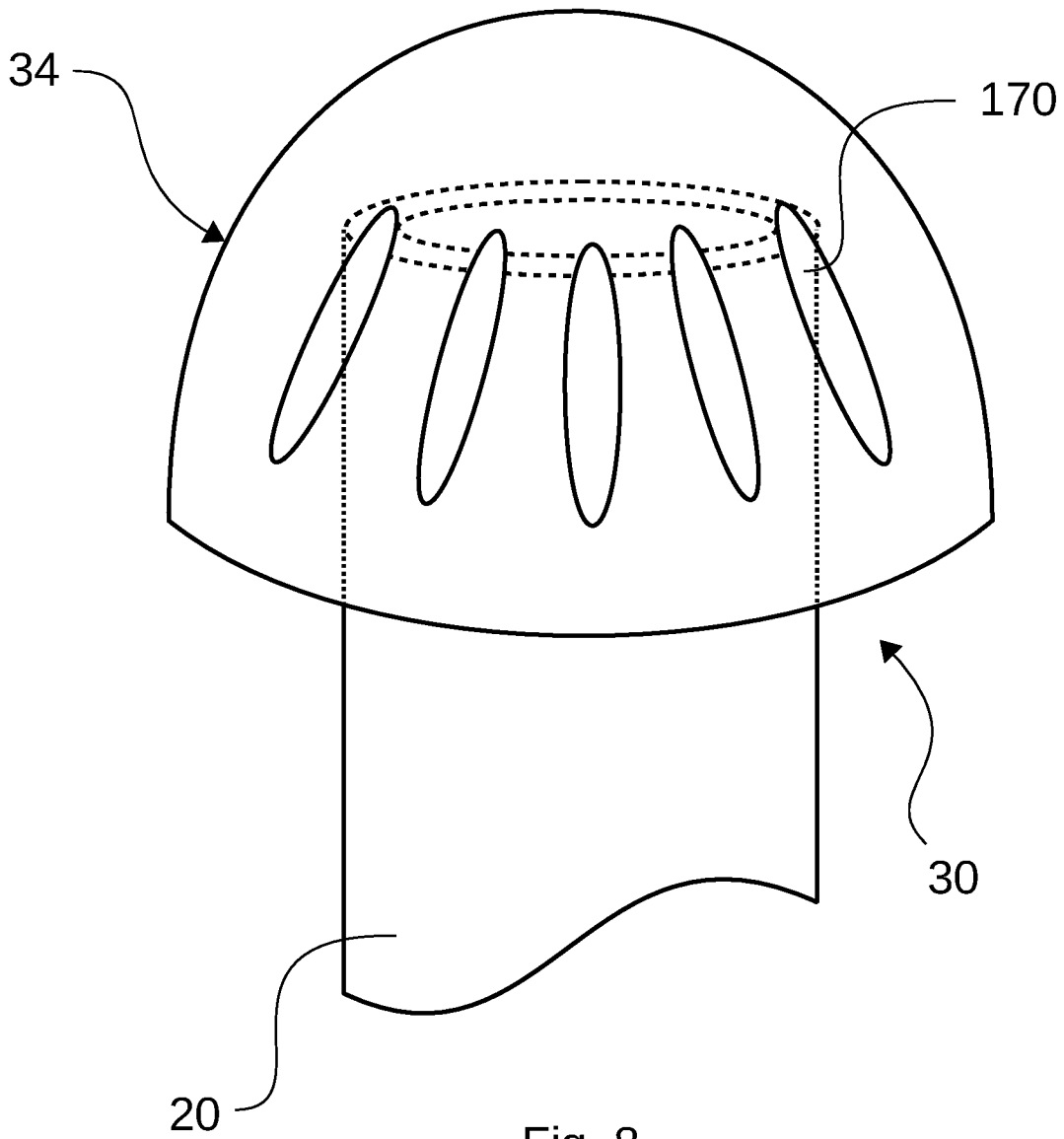

Fig. 8

9/11

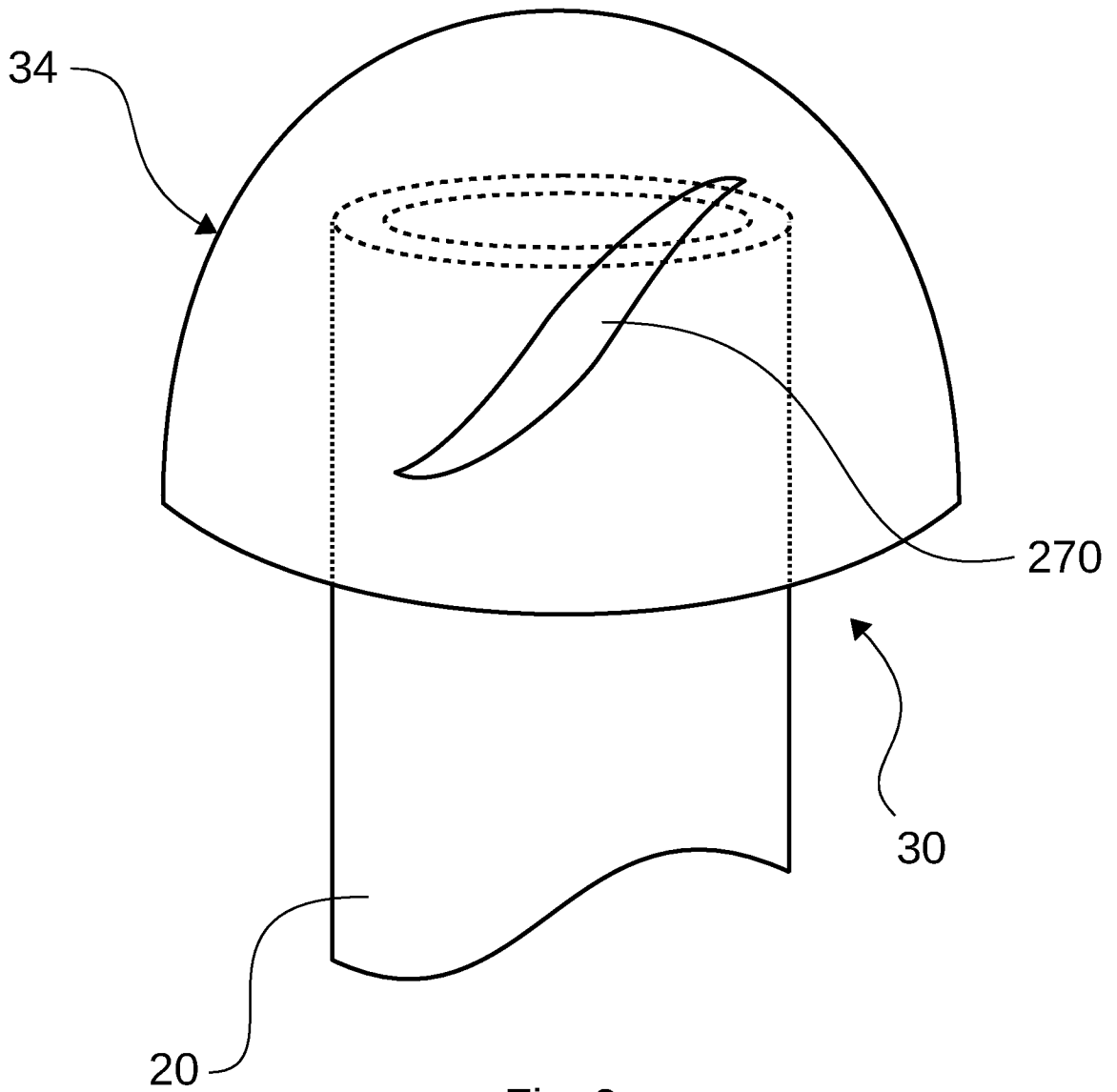

Fig. 9

10/11

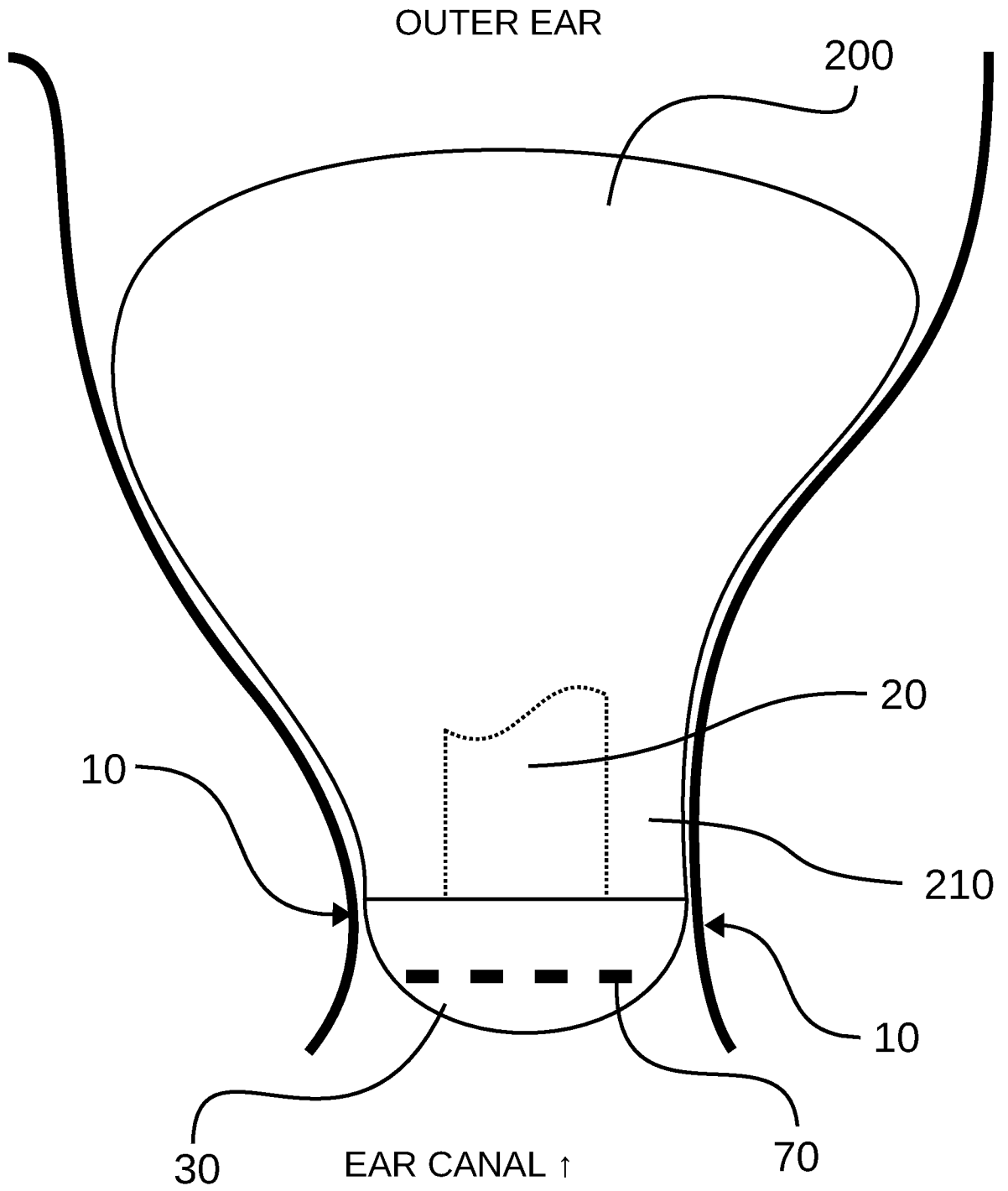

Fig. 10

11/11

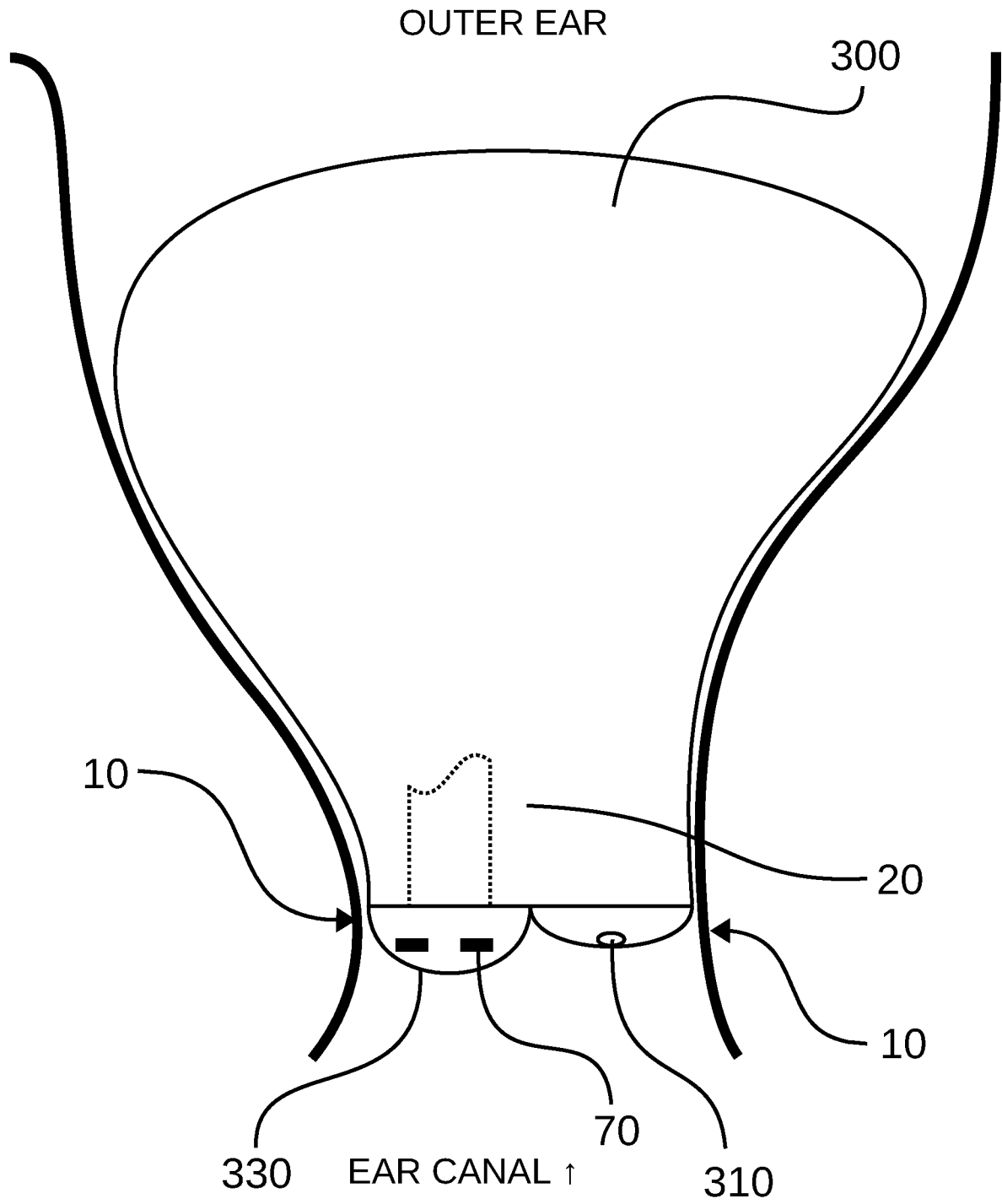

Fig. 11

INTERNATIONAL SEARCH REPORT

International application No
PCT/US2011/027902

A. CLASSIFICATION OF SUBJECT MATTER
INV. H04R25/00
ADD.
According to International Patent Classification (IPC) or to both national classification and IPC

B. FIELDS SEARCHED
Minimum documentation searched (classification system followed by classification symbols)
H04R A61F

Documentation searched other than minimum documentation to the extent that such documents are included in the fields searched

Electronic data base consulted during the international search (name of data base and, where practical, search terms used)
EPO-Internal, WPI Data

C. DOCUMENTS CONSIDERED TO BE RELEVANT

Category*	Citation of document, with indication, where appropriate, of the relevant passages	Relevant to claim No.
X	WO 2006/094502 A1 (WIDEX AS [DK]; OLSEN JOERGEN MEJNER [DK]; ESPERSEN CHRISTIAN BOHL [DK]) 14 September 2006 (2006-09-14)	1-9
Y	page 9, line 4 - page 10, line 20 page 13, line 1 - page 14, line 2 figures 2,6-8	10
Y	----- US 2008/118095 A1 (FLETCHER THOMAS G [CA]) 22 May 2008 (2008-05-22)	10
A	figures 1-4 paragraphs [0020] - [0021]	1-9
A	----- DE 24 55 511 A1 (SEEBURG CORP) 30 October 1975 (1975-10-30) page 3, line 22 - page 4, line 28 figures 1-3 -----	1-10

Further documents are listed in the continuation of Box C.

See patent family annex.

* Special categories of cited documents :

- "A" document defining the general state of the art which is not considered to be of particular relevance
- "E" earlier document but published on or after the international filing date
- "L" document which may throw doubts on priority claim(s) or which is cited to establish the publication date of another citation or other special reason (as specified)
- "O" document referring to an oral disclosure, use, exhibition or other means
- "P" document published prior to the international filing date but later than the priority date claimed

- "T" later document published after the international filing date or priority date and not in conflict with the application but cited to understand the principle or theory underlying the invention
- "X" document of particular relevance; the claimed invention cannot be considered novel or cannot be considered to involve an inventive step when the document is taken alone
- "Y" document of particular relevance; the claimed invention cannot be considered to involve an inventive step when the document is combined with one or more other such documents, such combination being obvious to a person skilled in the art.
- "&" document member of the same patent family

Date of the actual completion of the international search 2 November 2011	Date of mailing of the international search report 09/11/2011
--	--

Name and mailing address of the ISA/ European Patent Office, P.B. 5818 Patentlaan 2 NL - 2280 HV Rijswijk Tel. (+31-70) 340-2040, Fax: (+31-70) 340-3016	Authorized officer Rogala, Tomasz
--	--

INTERNATIONAL SEARCH REPORT

Information on patent family members

International application No

PCT/US2011/027902

Patent document cited in search report	Publication date	Patent family member(s)	Publication date
WO 2006094502	A1	14-09-2006	
		AU 2005328945 A1	14-09-2006
		CA 2598819 A1	14-09-2006
		CN 101138273 A	05-03-2008
		EP 1856947 A1	21-11-2007
		JP 4709274 B2	22-06-2011
		JP 2008532445 A	14-08-2008
		US 2008013767 A1	17-01-2008

US 2008118095	A1	22-05-2008	
		WO 2008061335 A1	29-05-2008

DE 2455511	A1	30-10-1975	
		AT 336104 B	25-04-1977
		CH 580853 A5	15-10-1976
		DK 585474 A	23-10-1975
		ES 432956 A1	01-11-1976
		US 3934100 A	20-01-1976
