

[54] **DISTRIBUTOR APPARATUS**
 [72] Inventor: **Claude Schindler, Geneva, Switzerland**
 [73] Assignee: **Zyma S.A., Vand, Switzerland**
 [22] Filed: **Dec. 21, 1970**
 [21] Appl. No.: **99,854**

3,456,849 7/1969 Svostrand.....222/181 X
 3,464,412 9/1969 Schwartz.....222/386 X
 2,653,603 9/1953 Heiv.....222/179 X

FOREIGN PATENTS OR APPLICATIONS

668/26 2/1926 Australia.....222/325

Primary Examiner—Robert B. Reeves
Assistant Examiner—Larry Martin
Attorney—Stevens, Davis, Miller & Mosher

[30] **Foreign Application Priority Data**
 Dec. 29, 1969 Switzerland.....19357/69

[52] U.S. Cl.....**222/95, 222/391**
 [51] Int. Cl.....**B65d 35/54**
 [58] Field of Search.....222/92, 93, 95, 96, 103, 105,
 222/106, 107, 214, 179, 181, 325, 326, 327,
 386, 387, 390, 391

[56] **References Cited**

UNITED STATES PATENTS

2,728,493 12/1955 Spurgeon.....222/390 X
 3,221,941 12/1965 Lott.....222/105 X
 3,237,815 3/1966 Ogle.....222/386
 1,754,259 4/1930 Brown et al.222/179

[57] **ABSTRACT**

A distributor for a liquid product comprises a body having support means for fixation to a wall or the like, a crushable interchangeable recipient containing the liquid product housed in said body, and a piston resting by gravitation on the recipient. A horizontally displaceable operating lever is connected to means for actuating the piston, and cam means transform a horizontal movement of the operating lever into a vertical movement of the piston-actuating means to lower the piston and thus crush the recipient by a determined quantity, thereby causing outflow of a dosed quantity of product.

3 Claims, 4 Drawing Figures

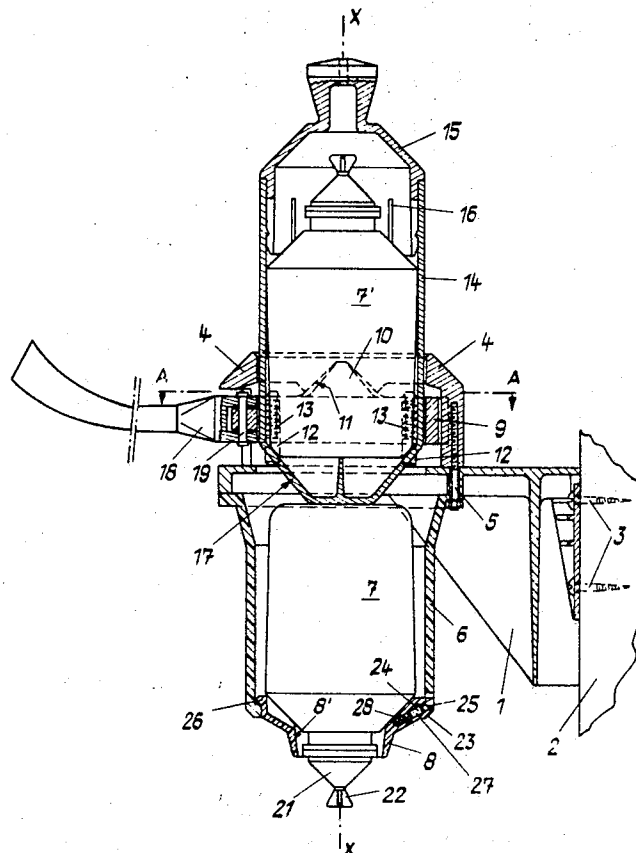
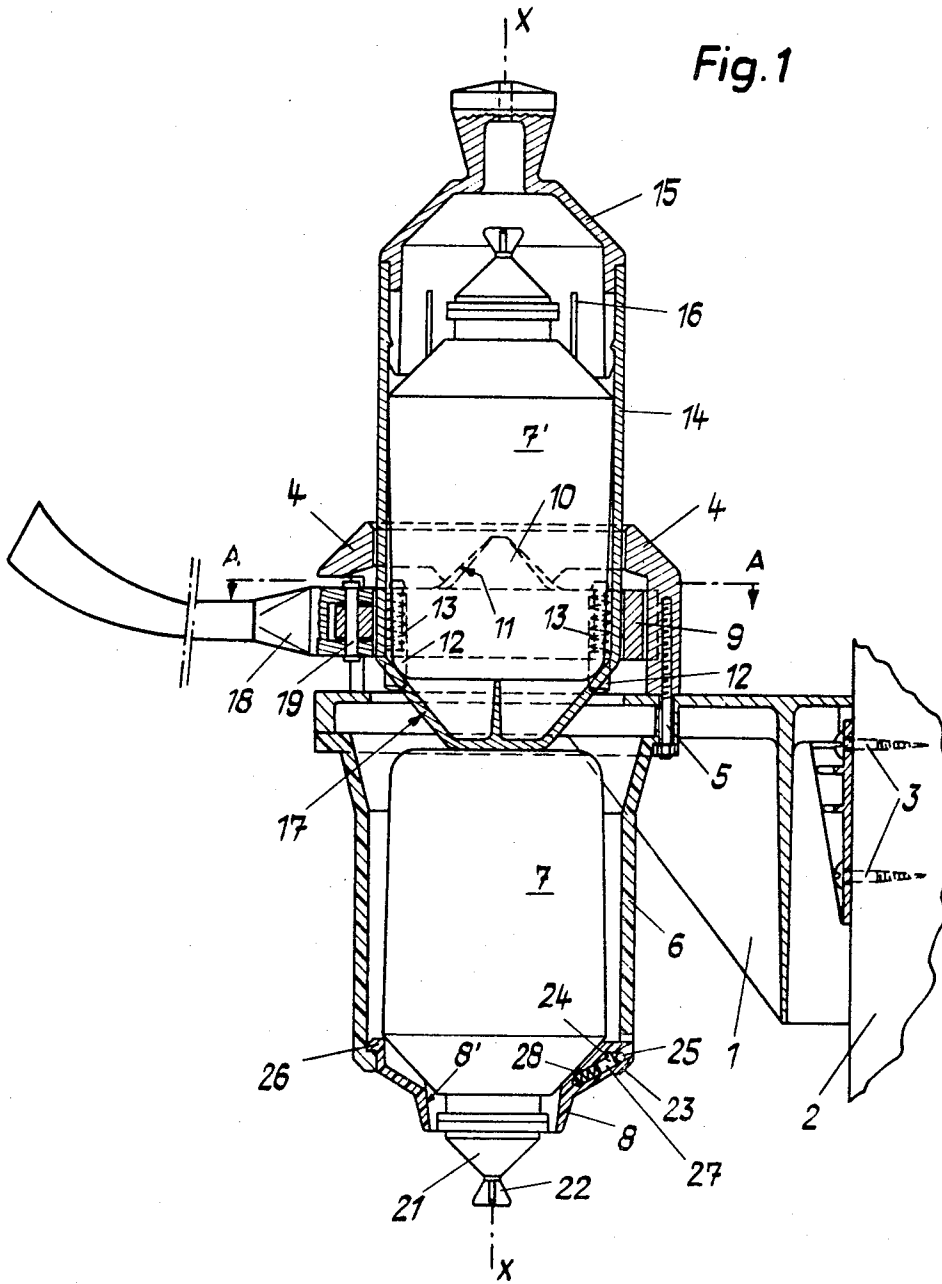

Fig. 1



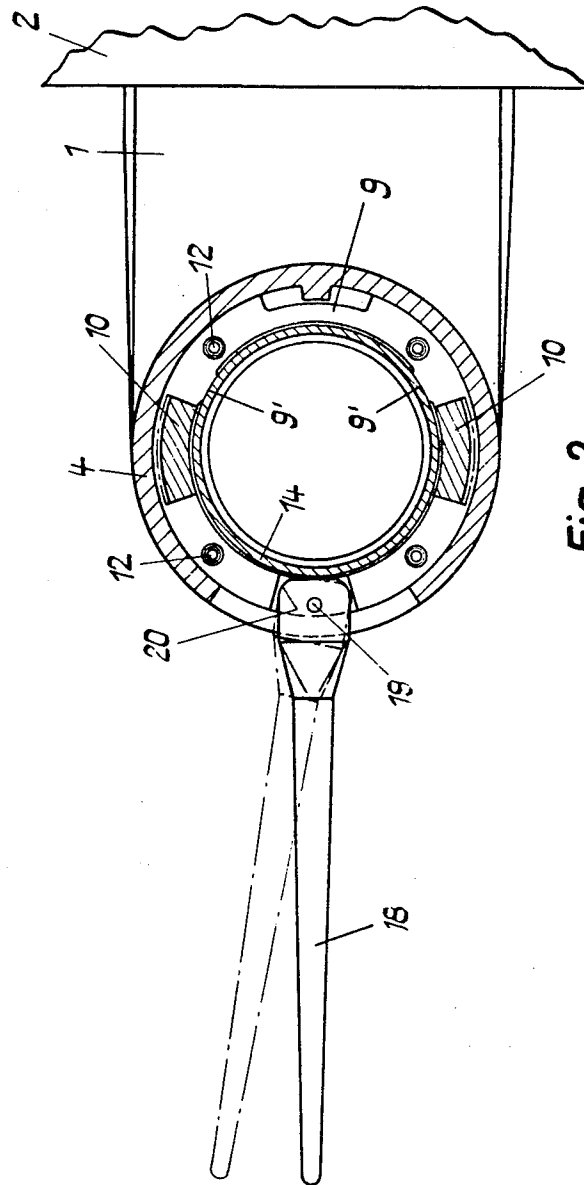

Fig. 2

Fig. 3

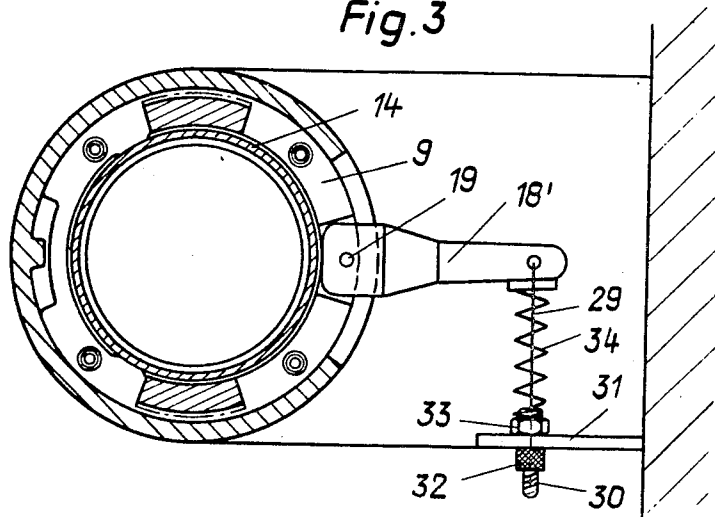
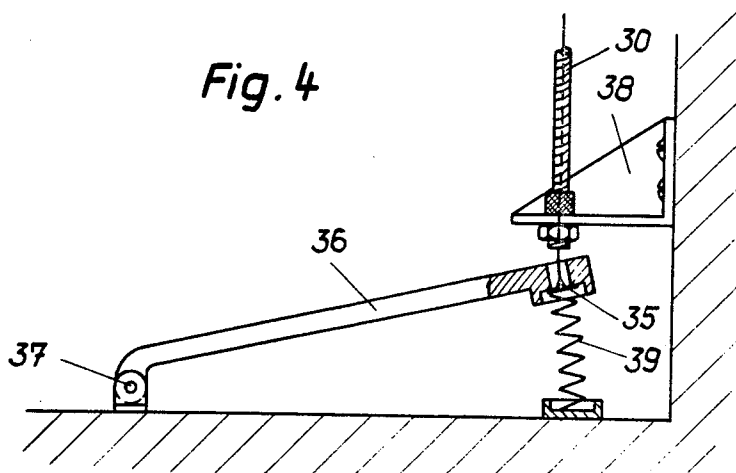

Fig. 4



DISTRIBUTOR APPARATUS

BACKGROUND OF THE INVENTION

This invention relates to distributors for liquid products, in particular for liquid soap, of the type comprising a body having support means for fixation to a wall and an interchangeable product-containing recipient located in the body.

Such apparatus, provided with interchangeable recipients containing, for example, liquid soap, have already been proposed. The problem consisting of the distribution of an accurate dose of the liquid product has however not been solved in a satisfactory manner. It is also known to operate the apparatus by means of a pneumatic pedal. Such operation, although practical for the user, is relatively complicated and is not of reliable operation.

SUMMARY OF THE INVENTION

The present invention therefore aims at remedying the drawbacks in known distributor apparatus.

Accordingly the invention concerns a distributor for a liquid product comprises a body having support means for fixation to a wall or the like, a housing in said body, and an at least partly crushable interchangeable recipient containing the liquid product being housed in said housing. The improvement according to the invention comprises a piston resting by gravitation on the recipient, a horizontally displaceable operating lever connected to means for actuating the piston, means for transforming a horizontal movement of the operating lever into a vertical movement of the piston-actuating means in order to lower the piston and thus crush the recipient by a determined quantity, and outlet means including means for dosing the quantity of product which flows out of the recipient.

DESIGNATION OF THE DRAWINGS

The accompanying drawings show, by way of example, an embodiment of a distributor according to the invention, and a variant thereof. In the drawings:

FIG. 1 is an axial cross-section of the distributor;

FIG. 2 is a plan view, partially in cross-section according to line A—A, of FIG. 1;

FIG. 3 is a view similar to FIG. 2 of a variant;

FIG. 4 is a side elevation, partially in cross-section, of a detail of this varied embodiment.

DESCRIPTION OF A PREFERRED EMBODIMENT

The distributor shown comprises a bracket 1 for fixation to a wall 2 by means of screws 3. A support ring 4 is fixed on the bracket 1 by bolts 5 which also serve to hold a receptacle 6 which forms, together with the ring 4, the body of the apparatus. An interchangeable container 7 having a thin crushable wall is placed in the receptacle 6, the lower end of which is provided with a removable base 8 to enable introduction of the container 7 into the receptacle 6, or its extraction, as will be described in detail further on.

A crown 9 is mounted for rotational and axial movement in the support ring 4. For this purpose, the crown 9 is provided with a protuberance 10 at diametrically opposite points, said protuberance being parallel to the axis of the ring 4 and having inclined edges forming a cam. The protuberance 10 engages in a recess 11 of

corresponding shape in the support ring 4. The protuberance could alternatively be provided on the ring and the recess in the crown. The crown 9 is mounted on guide rods 12, each provided with a return spring 13.

A cylindrical piston 14 is axially slidably mounted in the crown 9 to freely seat by gravitation on the crushable container 7. The piston is hollow in order to be able to receive a replacement container 7' containing the liquid product to be distributed. The open upper end of the piston 14 receives a removable cover 15 elastically held in the piston by a sleeve split at 16. The lower end of piston 14 has a trunco-conical part 17 adapted to the internal shape of container 7 when the latter is crushed to the maximum, in order to enable extraction of all of the product, as will be described hereafter.

A lever 18 forming a handle is articulated on the crown 9 by a vertical axle 19 and is also angularly displaceable about the vertical axis X—X of the apparatus upon rotation of the crown 9. The inner end 20 (FIG. 2) of lever 18 is arranged so as to form a driving cam for piston 14.

The interchangeable container 7 is provided with a dosing valve in plastic material, shown generally by 21, closed at an outlet nozzle (desoperculator) 22. This valve 21 could also be integral with the lower extremity of receptacle 6. In the shown example, the valve 21 could be mounted in opening 8' of the base 8.

This valve is described in co-pending application Ser. No. 107243 corresponding to Swiss Pat. application No. 822/70 filed in the same name.

The removable base 8 is connected to the receptacle 6 by means of a protuberance 23 comprising an elongated hole 24 in which passes a pin 25 fixed to the receptacle. Clamping means 26 are provided at a point diametrically opposite the connexion 23—25. A piston 27 urged by a spring 28 is housed in a bore in the wall of base 8, this piston 27 elastically urging the base 8 towards the closed position. To open the base, it is sufficient to push it against the action of spring 28, in order to bring the pin 25 to the opposite end of the elongated hole 24, which allows the clamping means 26 to be unhooked.

The described apparatus operates as follows:

A full container 7 is introduced into the receptacle 6 either from underneath by opening the base 8, or by firstly removing the piston 14 from above. Once the recipient 7 and the piston are positioned as shown in FIG. 1, the user operates the lever 18, for example with the elbow in order to leave the hands free and ready to receive a dose of liquid product delivered by the distributor. By moving the lever 18 in the clockwise direction (FIG. 2), the end 20 of this lever applies against the piston 14, and clamps it against bearing surface 9' of the crown 9. The piston 14 is thus angularly fixed to the crown 9 and these two parts are angularly displaced about the axis X—X of the apparatus with a simultaneous downward movement produced by cooperation of the cam-forming protuberance 10 with the recess 11. By bringing the lever 18 back in the opposite direction, the piston 14 is disengaged from bearing surface 9' and the crown 9 moves up again under the action of the return springs 13 which were compressed during the downward movement of the crown, and due to the action of the cam-forming protuberance 10 with the recess 11.

Upon each operation, the piston 14 moves down by a certain amount and crushes the recipient 7 by a determined quantity, thus causing the outflow of a dose of the liquid product. When the piston 14 reaches the end of its path, its trunco-conical end 17 fully crushes the recipient 7 and espouses the internal shape of the latter, in such way that all of the liquid product is driven out of the recipient.

Instead of a hand control, a foot-control could be used by connecting the lever 18 to a Bowden cable ending with an operating pedal, as shown in FIGS. 3 and 4.

In this variant, the hand operated lever 18 is replaced by a shorter lever 18' pivoting about a vertical axis 19 on the crown 9, as in the preceding embodiment.

The outer end of lever 18' is connected to a Bowden cable 29 whose sheath 30 is fixed in known manner to a support 31, by means of a threaded socket 32 and a nut 33, a return spring 34 being located between the lever 18' and the threaded sleeve 33. The other end of the Bowden cable 29 comprises a head 35 supported in the upper part of a pedal 36 pivoted on the ground about a horizontal axis 37. The sheath 30 is attached at its lower end to a bracket 38 in the same way as at its upper end. A return spring 39 is placed between the pedal 36 and the ground in order to urge the pedal towards its inclined position as shown.

The operation of the described variant can be easily seen from the drawing.

By pressing the foot on the pedal 36 against the force of the return spring 39, the cable 29 is caused to angularly move the lever 18' which acts on the piston 14 as has been described with reference to FIG. 2.

After the outflow of a dose of the liquid product, the pedal 36 returns to its initial position and the springs 39 and 34 bring the members back to the initial position shown in FIGS. 3 and 4, the distributor thus being ready for the distribution of a further dose of product.

What is claimed is:

1. A distributor for a liquid product comprising a support ring for fixation to a wall or the like, a housing fixedly attached to the support ring, a collapsible interchangeable container containing liquid product being housed in said housing, a piston displaceable in said ring and resting by gravitation on said container, a

horizontally displaceable operating lever articulated on a crown mounted for rotational and axial movement in said ring in a manner so as to clamp the piston and the crown upon angular displacement of the lever and cam means between the support ring and the crown for transforming the rotational movement of the crown into an axial downward movement of the crown, and of the piston which is temporarily clamped thereto.

2. A distributor for a liquid product comprising a support ring for fixation to a wall or the like, a housing fixedly attached to the support ring, a collapsible interchangeable container containing the liquid product being housed in said housing, a piston displaceable in said ring and resting by gravitation on said container, a horizontally displaceable operating lever articulated on a crown mounted for rotational and axial movement in said ring in a manner so as to clamp the piston and the crown upon angular displacement of the lever and cam means between the support ring and the crown for transforming the rotational movement of the crown into an axial downward movement of the crown, and of the piston which is temporarily clamped thereto, said crown being provided at diametrically opposed points with a cam-forming protuberance engaging in a recess of corresponding shape in the support ring, the crown being mounted on guide rods provided with springs tending to return the crown to its initial upper position after having been moved down with the piston.

3. A distributor for a liquid product comprising a support ring for fixation to a wall or the like, a housing fixedly attached to the support ring, a collapsible interchangeable container containing the liquid product being housed in said housing, a piston displaceable in said ring and resting by gravitation on said container, a horizontally displaceable operating lever articulated on a crown mounted for rotational and axial movement in said ring in a manner so as to clamp the piston and the crown upon angular displacement of the lever and cam means between the support ring and the crown for transforming the rotational movement of the crown into an axial downward movement of the crown, and of the piston which is temporarily clamped thereto, said housing having a removable base to enable the insertion or removal of a container into or from the housing.

* * * * *

50

55

60

65