

(No Model.)

2 Sheets—Sheet 1.

E. S. HAWKS.
SCRUBBING MACHINE.

No. 466,681.

Patented Jan. 5, 1892.

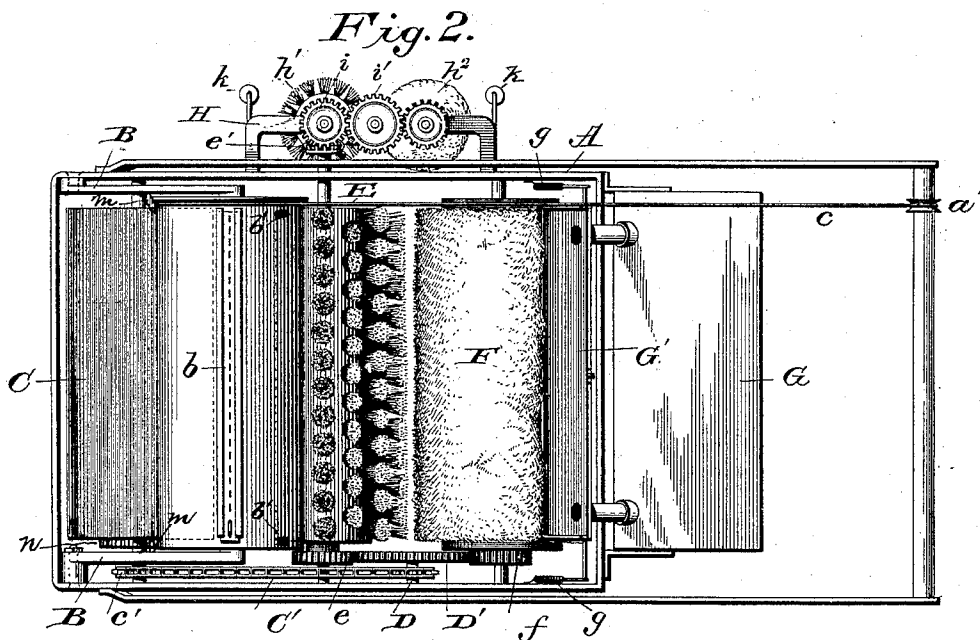
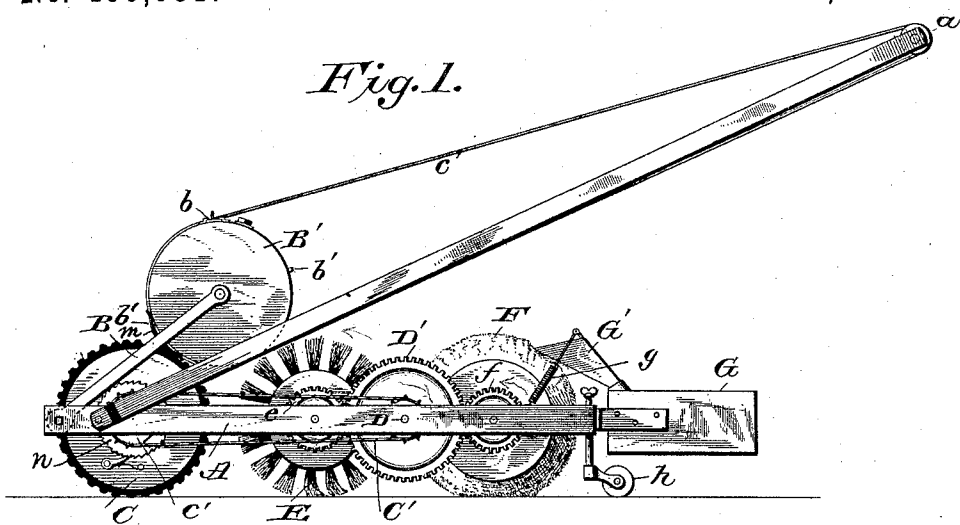

Enos S. Hawks.

Inventor

by *[Signature]*
Attorney

Witnesses
[Signature]
[Signature]

(No Model.)

2 Sheets—Sheet 2.

E. S. HAWKS.
SCRUBBING MACHINE.

No. 466,681.

Patented Jan. 5, 1892.

Fig. 3.

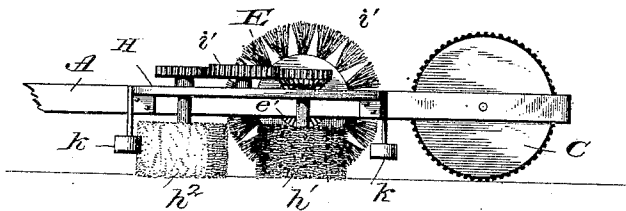

Fig. 4.

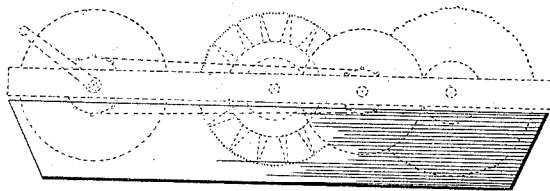
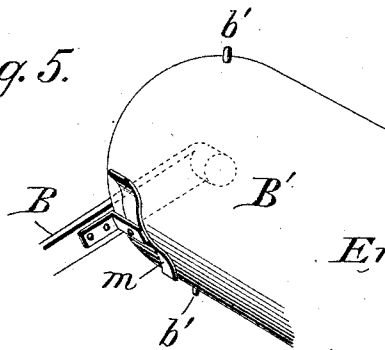

Fig. 5.



Enos S. Hawks.

Inventor

by *[Signature]*
Attorney

Witnesses
L. S. Elliott
W. Johnson

UNITED STATES PATENT OFFICE.

ENOS S. HAWKS, OF CUMMINGTON, MASSACHUSETTS.

SCRUBBING-MACHINE.

SPECIFICATION forming part of Letters Patent No. 466,681, dated January 5, 1892.

Application filed February 5, 1891. Serial No. 380,367. (No model.)

To all whom it may concern:

Be it known that I, ENOS S. HAWKS, a citizen of the United States of America, residing at Cummington, in the county of Hampshire and State of Massachusetts, have invented certain new and useful Improvements in Scrubbing-Machines; and I do hereby declare the following to be a full, clear, and exact description of the invention, such as will enable others skilled in the art to which it appertains to make and use the same, reference being had to the accompanying drawings, and to letters of reference marked thereon, which form a part of this specification.

This invention relates to improvements in scrubbing-machines.

The object of the invention is to provide a device consisting of a rotary brush, mop, driving-wheel, and reservoirs, which are mounted upon and carried by a frame, so that when the device is moved over a floor the said floor will be scrubbed and the water gathered up by a mop and deposited in the receptacle at the end of the machine; and the invention contemplates providing such a scrubbing-machine with a device for washing the base-boards, said device being detachable from the main frame; and it consists in the construction and combination of the parts, as will be hereinafter fully set forth, and particularly pointed out in the claims.

In the accompanying drawings, forming part of this specification, Figure 1 is a side view of a scrubbing-machine. Fig. 2 is a plan view showing the device for washing the base-board applied. Fig. 3 is a side view of the device for washing the base-board, showing it applied to the scrubbing-machine. Fig. 4 is a diagram view showing the manner of washing or cleansing the scrubbing-brush and mop, and Fig. 5 is a detail perspective view of the spring with which the lugs on the cylinder engage.

A refers to a rectangular frame, which is provided at suitable points with perforations which form bearings for the transverse shafts carrying the scrubbing mechanism, and to said frame is pivotally attached the handle for pushing the machine across the floor. To the front portion of the rectangular frame A are pivotally secured supports B, to the upper ends of which is journaled a cylindrical

reservoir B', said reservoir having an aperture for filling the same and a slide *b*, with perforations so spaced that when the slide *b* is properly adjusted they will register with perforations in the reservoir, said slide having a suitable ring for operating the same manually. The cylinder B' is provided with projecting lugs *b'*, which are adapted to engage with a spring *m*, carried by the supports B, said spring having a portion bent to lie in the path of the lugs. The lugs and spring coact to hold the reservoir B' in such a position that the perforated slide will be either at the top or bottom of the reservoir, said lugs being located diametrically opposite each other. Around the reservoir B' passes a belt or band *c*, which leads up to and around a roller *a'* at the upper end of the handle, and by means of this belt the reservoir is turned.

C refers to the main drive-wheel, which is journaled in the frame A and is preferably covered with corrugated rubber. Upon one end of the shaft which supports the driving-wheel is fixed a sprocket-wheel *c'*, over which passes a drive-chain C', and adjacent thereto is a ratchet-wheel *n*, with which the spring-pawl shown engages to cause the shaft and driving-wheel to rotate in unison when the machine is pushed forward, the pawl allowing the apparatus to be drawn rearwardly without imparting movement to the sprocket-wheel. The chain C' from the sprocket-wheel on the drive-shaft passes around a smaller sprocket-wheel on the shaft D, said shaft also carrying a gear-wheel D', which meshes with the gear-wheels *e* and *f*, mounted on the mop and brush shafts.

E refers to the rotary brush, which is rigidly fixed upon the shaft carrying the gear-wheel *e*, said shaft also carrying a beveled gear-wheel *e'* for the purpose to be hereinafter set forth.

F refers to the mop, which consists of a cylinder covered with suitable absorbent material. It will be noted that the brush E and mop F by the system of gearing employed rotate in an opposite direction from that which the frame is moved, thus operating more effectively than if they rotated in the same direction.

G refers to a reservoir, which is suitably at-

tached to the rear end of the frame A and carries a forwardly-inclined trough G', which contacts with the circumference of the mop and is held against the same by springs g, extending from said trough to the frame, as shown. At each end of the trough is a spout or conductor which leads into the reservoir G.

Centrally the rear end of the frame A is provided with a caster-wheel h, which can be vertically adjusted by means of a set-screw.

The beveled gear-wheel e', hereinbefore referred to, is employed when it is desired to use vertical scrubbers for washing the base-boards, in which event a supplemental frame H, carrying a rotary brush h' and a mop h², is secured to the frame A, the shaft of the rotary brush carrying a beveled gear-wheel which meshes with the gear-wheel e', said shaft also carrying a gear-wheel i for imparting motion to the mop through the medium of the gear-wheel i'. The frame H is clamped by means of set-screws to the frame A and carries rollers k k, adapted to travel along the base-board.

When it is desired to cleanse the scrubbing-brushes, it can be done by setting the frame A in a pan, as shown in Fig. 4, and by rotating the parts therein they can be readily cleaned.

From the foregoing description of the parts and the accompanying drawings the operation of my improvement will be apparent.

Having thus described my invention, what I claim as new, and desire to secure by Letters Patent, is—

1. In a scrubbing-machine, the combination of the rotary brush and mop cylinders journaled upon a frame and geared to each other and to a drive-wheel, so as to be rotated in an opposite direction from said drive-wheel, substantially as set forth.

2. In a scrubbing-machine, the combination of a frame having journaled therein upon horizontal shafts a drive-wheel and in the rear of the same a rotary brush and rotary cylinder covered with absorbent material, together with a water-reservoir carried by the frame in front of the rotary brush, and gearing for connecting the brush and mop to the drive-wheel.

3. The combination, in a scrubbing-ma-

chine, of a driving wheel or cylinder, a rotary brush and a mop geared to each other, a reservoir for applying water to the brush, and a reservoir for receiving water from the mop, the brush and mop being geared to each other to turn in opposite directions, substantially as shown, and for the purpose set forth.

4. In a scrubbing-machine, the combination of the rectangular frame having a handle, and a rotary water-reservoir carried by the frame and connected by a band or belt to the handle, substantially as set forth.

5. The combination, with a scrubbing-machine constructed substantially as set forth, of a horizontal rotary reservoir having a longitudinal series of openings; a slide operating above the same, and lugs carried by said reservoir and adapted to contact with a spring, as set forth.

6. The combination, in a scrubbing-machine, of a frame, a rubber-covered driving-cylinder journaled therein, transverse shafts having rigidly attached thereto rotary cylinders, one of said cylinders being provided with brushes and the other with a surface of absorbent material, a reservoir G, carrying a trough, the forward edge of which contacts with the absorbent material on the rear cylinder, and springs for holding said trough in engagement with the said absorbent material, substantially as set forth.

7. The combination, with a scrubbing-machine constructed substantially as shown and provided with a beveled pinion e', of a frame carrying a vertical brush and mop and a train of gearing driven by said beveled wheel, substantially as shown, and for the purpose set forth.

8. In combination with the main frame A, a frame H, having vertical contact-rollers k, vertical brush h' and mop h², and gearing for actuating the same from one of the rotary parts of the scrubbing-machine, substantially as set forth.

In testimony whereof I affix my signature in presence of two witnesses.

ENOS S. HAWKS.

Witnesses:

ALICE E. HAWKS,
RUSSELL R. PACKARD.