

(No Model.)

S. ROSS, Jr.  
SAND PAPER ROLL.

No. 426,862.

Patented Apr. 29, 1890.

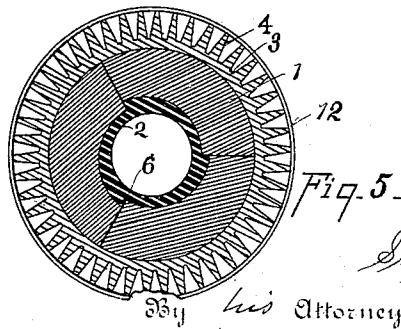
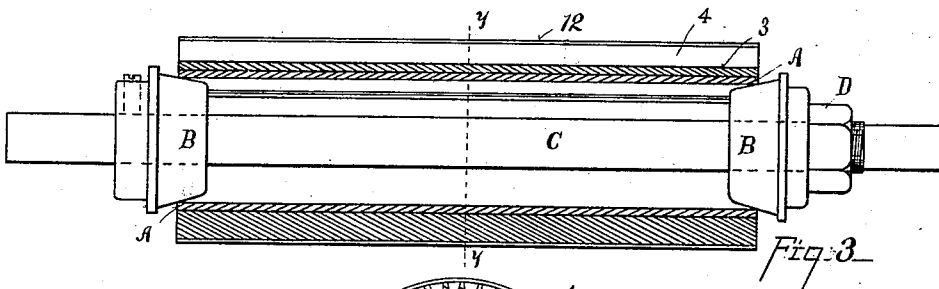
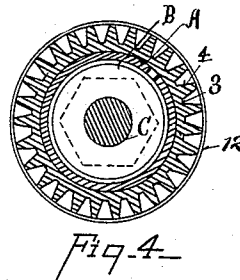
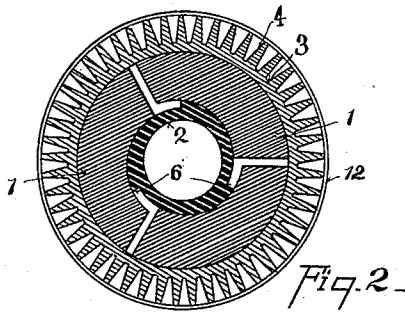
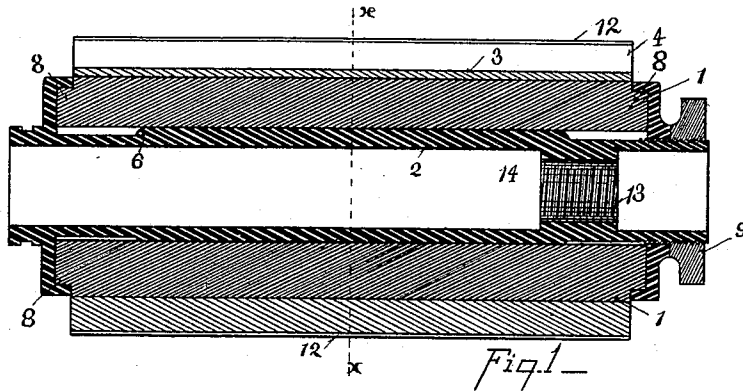

Witnesses  
C. W. Miles,  
T. Simmons

Inventor  
Simon Ross  
his Attorneys Wood & Bond

# UNITED STATES PATENT OFFICE.

SIMON ROSS, JR., OF CINCINNATI, OHIO.

## SAND-PAPER ROLL.

SPECIFICATION forming part of Letters Patent No. 426,862, dated April 29, 1890.

Application filed October 31, 1889. Serial No. 328,763. (No model.)

*To all whom it may concern:*

Be it known that I, SIMON ROSS, Jr., a citizen of the United States, and a resident of Cincinnati, in the county of Hamilton and State of Ohio, have invented certain new and useful Improvements in Sand-Paper Rolls, of which the following is a specification.

This invention relates to that type of sand-papering devices wherein a cylindrical body of rubber surrounds a cylindrical support and is provided with elastic fingers or projections which hold the sand-paper by frictional contact therewith, as in the Letters Patent No. 401,215, issued to me April 9, 1889.

The objects of my present invention are to improve the prior construction, to provide novel means whereby the fingers or projections may be caused to act on the sand-paper with more or less pressure, as occasion demands, to provide a novel sand-paper roll which can be expanded and contracted, and to provide means for limiting or stopping the expansion of the roll.

To accomplish all these objects my invention involves the features of construction, the combination or arrangement of devices, and the principles of operation hereinafter described and claimed, reference being made to the accompanying drawings, in which—

Figure 1 is a longitudinal vertical section of my improvement. Fig. 2 is a cross-section on line *x x*, Fig. 1. Fig. 3 is a longitudinal section of a modification thereof. Fig. 4 is a cross-section on line *y y*, Fig. 3. Fig. 5 is a similar view to Fig. 2, except that the roll is shown contracted instead of expanded, as in Fig. 2.

In the drawings, the numeral 1 indicates segmental sections arranged to form the body of the supporting-roll.

2 represents an expanding sleeve extending longitudinally between the segmental sections.

3 represents a rubber roll, having a series of radial projections 4 extending out from the periphery. The rubber roll 3 is preferably rigidly secured to the sections 1, and when the parts are put together they occupy normally the position shown in Fig. 5.

6 represents a series of eccentrics, which extend longitudinally along the sleeve or shaft 2. I have shown three. There should be one

for each segment. The rubber draws the segments out of center with the axial line of the shaft, as shown in Fig. 5. The edge of one segment is lifted above the abutting edge of the adjacent segment, thereby forming a sufficient space to receive the edge of the eccentric 6 and allow them to be inserted into position. When the eccentric is turned within the segments or the segments turned on the eccentrics, the segments 1 are spread apart by the eccentrics, as shown in Fig. 2. It is essential to have a considerable degree of expansion, because of the flexibility of the radial projections 4. It is also desirable to have the eccentrics extend nearly the whole length of the tube, so as to extend it equally throughout the whole length. In order to limit the radial expansion of the roll, I provide stops consisting of flange-collars 8, which engage over the sections 1, as shown in Fig. 1. In order to hold the sections to any desired degree of expansion, I provide a set-nut collar 9, which engages with threads on the exterior of the sleeve 2, which project through the roll a sufficient distance to allow the engagement of the nut. One of the stop-collars 8 is made integral with the sleeve 2; but it may be secured thereto in any desired manner. When the set-nut collar 9 is turned up, the sleeve carrying the eccentrics is held in a fixed position and the sand-paper 12 held in place on the roll. 13 represents screw-threads formed in the hub 14, formed on the interior of the sleeve 2, by means of which this roll may be attached to a revolving mandrel.

The roll operates as follows: In the normal position the segments will keep the position shown in Fig. 5. The sleeve carrying the eccentric 6 is inserted therein. The sleeve is then attached to the mandrel by the nut 13. The roll may be then readily turned on the mandrel backward, which forces the eccentrics 6 around against the segments 1, as shown in Fig. 2. When the desired expansion of the roll has been obtained, the set collar-nut 9 may be turned up and the parts held in position; but this is not necessary, and frequently not done in practice, as the centrifugal force will keep the roll suitably expanded. The eccentrics being gradual, the strain is not too great. When it is desired, however, to have a soft or slight expansion, so as to have

a soft roll, then the collar is turned up. It locks it to any desired degree of tautness. When it is desired to remove the sand-paper, the collar-nut 9 is slackened, the roll is turned  
 5 backward by hand, bringing the segments and eccentrics in position shown in Fig. 5, when the sand-paper can be readily slipped off and a new one inserted thereon. It is not necessary to expand the roll by hand, as the cen-  
 10 trifugal force when the machine is set in motion will turn the eccentric sleeve and expand the roll. It is thus automatically set in position, and this holds it from ever becoming loose. This is a great improvement over the  
 15 longitudinally-moving expanding device, as the friction on the roll to the right or left, as the case may be, tends to loosen it.

It is desirable to have the roll expanded radially throughout its entire length, and the  
 20 sleeve carrying these long segments is the best mode that I have invented. An inferior mode is shown in Figs. 3 and 4, in which A represents a split cylindrical ring. It is inserted and supports the rubber roll 3, having the radial  
 25 projections 4. B represents tapering collars, one of which is shown fast to the shaft C and the other one secured thereto by screw-threads. As the said threaded nut is turned  
 30 up the split ring A is expanded, thereby expanding the rubber roll 3. D represents a jam-nut for holding the parts in a fixed position when the taper nut B has been turned up and expanding the roll to the desired extent. Sustaining stop-flanges on the collars B may  
 35 be employed, and the split ring extended out radially beyond the rubber roll 3, as shown in Fig. 1.

Having described my invention, what I claim is—

40 1. A sand-paper roll consisting of the radially-expandible support, the cylindrical elastic body surrounding the expandible support and formed with a series of elastic projections,

the sand-paper held by frictional contact with the outer extremities of the projections, means  
 45 for expanding the support, and with it the elastic body to press the elastic projections against the inside of the sand-paper, and stops which serve to limit the radial expansion of  
 50 said support, substantially as described.

2. A sand-paper roll consisting of segmental sections uniformly adjustable in radial lines, a cylindrical elastic body surrounding the sections and expanded by the radial adjustment  
 55 of the latter, an axially-rotating shaft having longitudinal peripheral eccentrics for radially adjusting the sections and elastic body, and stops for limiting the radial outward movement of the sections, substantially as described.  
 60

3. A sand-paper roll consisting of a series of segmental sections, the cylindrical elastic body arranged thereupon and provided with radial extensions 4, and the axially-rotating  
 65 sleeve provided with a series of eccentrics, one for each segment, which extends longitudinally along the periphery of the sleeve to uniformly expand the segmental sections, substantially as described.  
 70

4. A sand-paper roll consisting of a series  
 70 of segmental sections 1, the elastic body 3, surrounding the sections and formed with radial yielding projections 4, the axially-rotating sleeve 2, having at its ends the flanged collars  
 75 8, engaging the ends of the segmental sections, and provided along its periphery with a series of eccentrics, one for each segmental section, and the screw-nut 9 on the sleeve outside one of the flanged collars, substantially as described.  
 80

In testimony whereof I have hereunto set my hand.

SIMON ROSS, JR.

Witnesses:

C. W. MILES,  
 T. SIMMONS.