

W. B. BARTRAM,  
Sewing Machine.

2 Sheets—Sheets 1.

No. 60,669.

Patented Jan. 1, 1867.

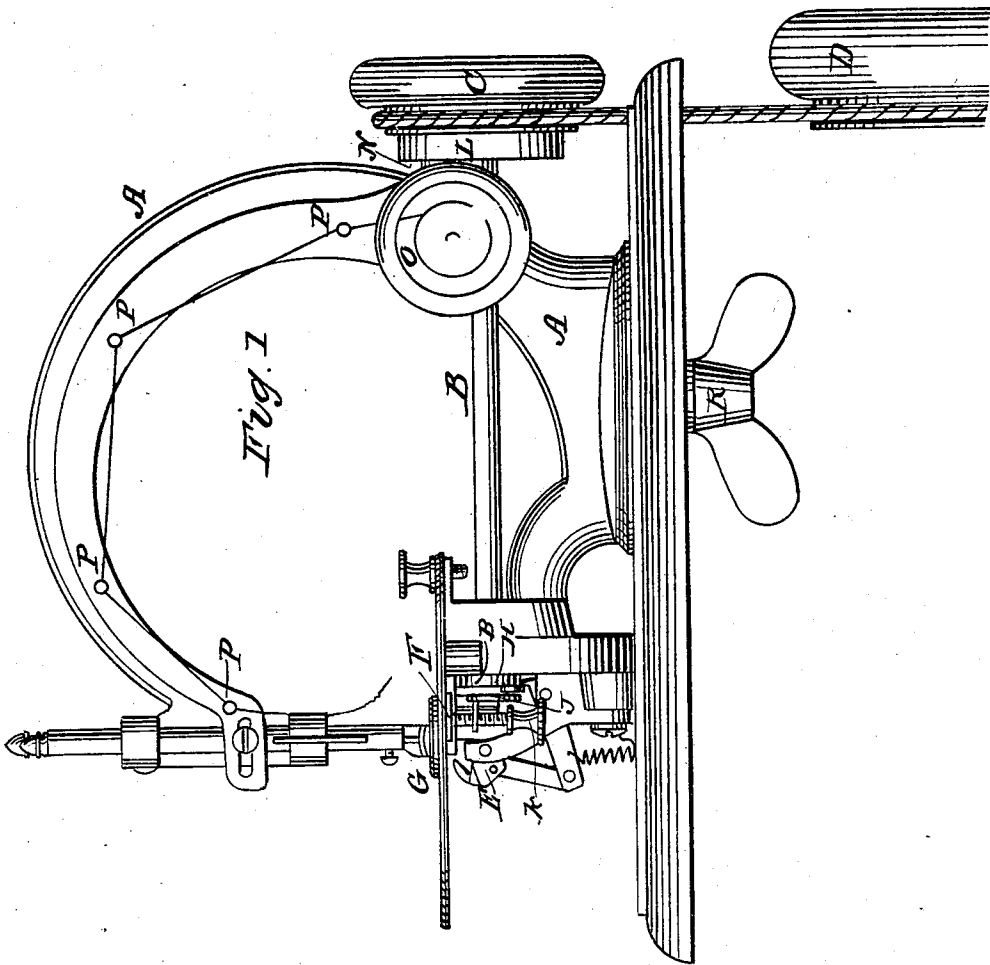

WITNESSES

Thos Connolly  
Thomas S. Parker

INVENTOR

W B Bartram  
By his atty A. B. Smith

W. B. BARTRAM,

Sewing Machine.

No. 60,669.

Patented Jan. 1, 1867.

Fig. 3

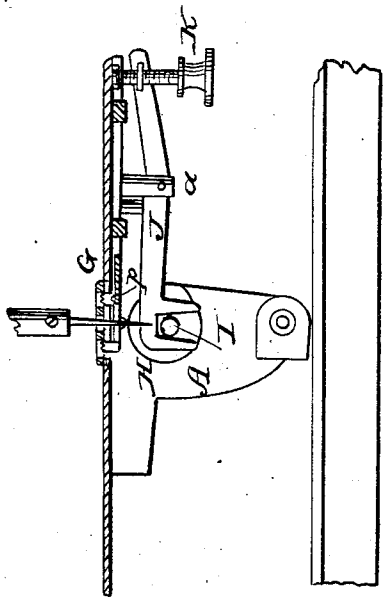

Fig. 4

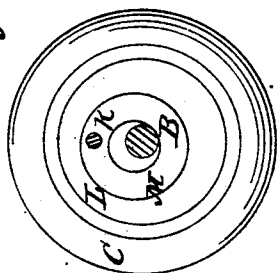

Fig. 5

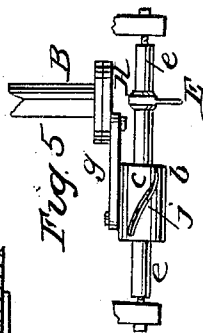

Fig. 6

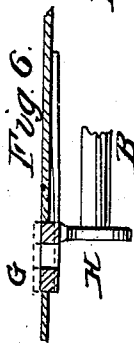
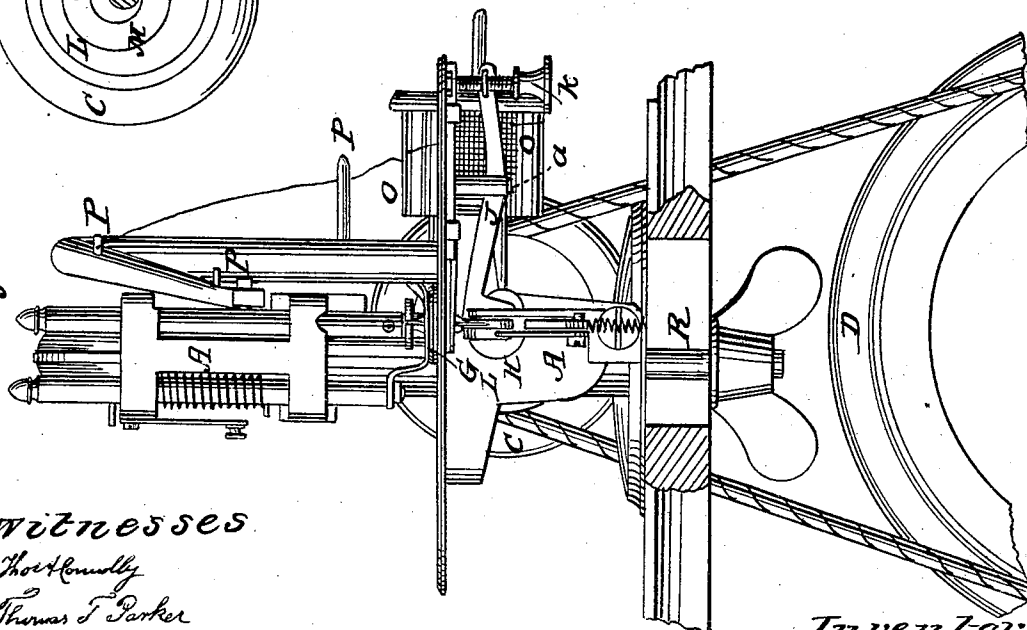

Fig. 2



Witnesses

Thos. Kennedy  
Thomas F. Parker

Inventor

W. B. Bartram  
By his atty  
R. O. Smith

# United States Patent Office.

WALKER B. BARTRAM, OF DANBURY, CONNECTICUT.

Letters Patent No. 60,669, dated January 1, 1867.

## IMPROVEMENT IN SEWING MACHINES.

The Schedule referred to in these Letters Patent and making part of the same.

### TO ALL WHOM IT MAY CONCERN:

Be it known that I, WALKER B. BARTRAM, of Danbury, in the county of Fairfield, and State of Connecticut, have invented a new and useful Improvement in Sewing Machines; and I do hereby declare the following to be a full, clear, and exact description of the same, reference being had to the accompanying drawings, in which—

Figure 1 is a side elevation of my machine.

Figure 2 is a front elevation of the same.

Figure 3 is a vertical transverse section through the needle slot.

Figure 4 is an elevation of the needle-driving eccentric.

Figure 5 represents a modified arrangement for operating the looping hook.

The sewing machine presented in this application relates to that class of sewing machines which employ but a single thread, though many of its features are equally applicable to any other class of sewing machines. My invention consists, first, in placing the looping hook so that it moves in a plane at right angles to the direction of the feed movement, and so timing the movements of said hook and the needle that they will operate properly in connection with each other, without regard to the direction of the motion of the driving-wheel; second, in the manner of tightening or slacking the driving belt by moving the machine itself to or from the driving-wheel; third, in the mode of procuring the desired tension; fourth, in the manner of constructing the driving eccentric; fifth, in the construction and arrangement of the feed.

That others may understand the construction and operation of my machine, I will particularly describe it.

A is the frame of the machine, to which all the working parts are attached. The driving shaft B passes through suitable boxes at the front and rear portion of the frame. At the rear end of the shaft B, is the driving pulley and eccentric, C, which receives motion from the driving-wheel D, by means of a belt, as is usual. The looping hook and the feeding mechanism receive their movements from cam or crank devices, situated at the front end of the shaft B. The looping hook E is, in shape, substantially as shown in fig. 1; it is hung upon a pivot or shaft, the axis of which is parallel with the line of movement of the feeding dog. As the needle is actuated by an eccentric upon the end of the same shaft, B, it is easy to so time the hook and needle that they will move properly in respect to each other, without regard to the direction in which the driving mechanism moves. To do this it is necessary, for instance, to set the eccentric which drives the needle at the extremity of its throw, when the needle is entirely depressed, and to set the mechanism which operates the hook so that, at the same moment, it shall be entirely thrown back. The parts must also be so arranged that from these two points the movements will be exactly the same, whether the shaft B revolves backward or forward. From this point, as the shaft revolves, the needle rises, leaving a slight loop of thread at the side. Through this loop the hook E passes as it is thrown forward, retaining the thread as the needle rises out of the cloth, and holding the loop until the needle passes through it at the next stroke. The position of the hook E, and the direction of its stroke, renders the formation of the stitch the same, whichever way the cloth may move. This cannot be the case if the hook moves in a plane parallel with the plane in which the feed moves, for the reason that the loop will slip from the hook a little sooner when the cloth moves in one direction than when it moves in the other; and the slightest inequality of operation in that respect will spoil the operation of the machine. The feeding mechanism is constructed with teeth, having equal angles on each side of the points, so that the cloth will be pierced and moved with equal facility in either direction. In this machine the feeding dog, F, has a rectilinear motion only, and the cloth is freed from the teeth of the dog by the work-lifter, G, which is caused to rise up at the proper moment, and raising the cloth from the feeding dog, retains it so until the dog has been withdrawn, and is prepared for another stroke. The work-lifter G is caused to rise and fall by a cam, H, on the end of the driving shaft B. In this application, the feeding dog is represented as being operated by an eccentric pin, I, set in the front end of the shaft B. Said pin lies within a tapering notch in the side of the arm J, which is pivoted to the feeding dog at  $a$ , as shown. The notch referred to is made with inclined or tapering sides, so that it is wider at the lower than at the upper end. The pin I quite fills the notch at the narrow end, and when in that position, the arm J, and the feeding dog F, are pushed back and forth, at every revolution, a distance equal to the throw of the eccentric pin; but when, by means of the screw K, the arm J is inclined, so that the pin I lies in the wider part of the notch, then the arm J will be moved only through a distance equal to the difference

between the width of the notch at that point and the throw of the eccentric pin. In the first-named position, the longest stitch within the capacity of the machine will be produced, and in the other case, the feed movement may be reduced to nothing. Between these two all gradations of length may be attained by regulating the position of the notch over the pin I, and this may be controlled by the screw K, or by any other of the well-known mechanical expedients adapted to such uses. In fig. 1, the hook E is represented as actuated by an arrangement of a compound lever, receiving motion from a cam on the forward end of the driving shaft B, but I consider the devices represented in fig. 5 as preferable for the purpose. They represent the construction which is adopted in practice, and for which I design to make application for Letters Patent at a future time. A brief reference to them is, however, inserted here, as not out of place. The looping hook E is mounted on a tumbling shaft, *e*, through which, also, a pin, *b*, is placed, at some little distance from the hook E. Upon the shaft *e* is placed a sleeve, *c*, which is provided with a diagonal slot, *f*, for the reception of the pin *b*. Now it will appear evident that if the said sleeve is moved back and forth, in the direction of the axis of the tumbling shaft, without being permitted to rotate on said axis, the diagonal slot *f*, and pin *b*, will cause the tumbling shaft and hook E to rotate a distance proportionate to the length and angle of the slot *f*. This motion of the sleeve is produced by a link, *g*, and an eccentric pin or crank at the end of the shaft B. The driving-wheel, L, has an eccentric groove turned in its face, and into this groove is loosely fitted the ring M. The pin, N, at the rear end of the needle arm, projects loosely into a suitable hole in the face of this ring, M, and prevents it from revolving on the axis of the driving shaft B, with the wheel L. As the driving-wheel L revolves upon its axis, the pin N rises and falls, influenced by the walls of the eccentric groove, just as though the ring M was not present; the ring, however, serves to fill the groove, and prevent the access of dust and dirt, and also to increase the amount of wearing surface, and therefore increase the durability of the machine. This is a point of great importance, for the relative action of the various parts of a sewing machine requires such nice adjustment, that the slightest enlargement of the orifice by wear, or the slightest decrease of the size of a pin from the same cause, may produce the most important differences in the timing and movements of the stitching apparatus. The tension O is a cylinder, within which the spool is placed, either upon a spool pin, or loosely. The thread is passed through a small hole in the side of this cylinder, and passed once or twice around it before being led to the guide loops P. The cylinder O may be revolved on its axis to increase or diminish the tension, thereby causing the thread to traverse a greater or less distance on its surface. It is proposed to construct these cylinders of glass, as presenting facilities for ornamentation, and an excellent surface for the purpose, though any other suitable material may be employed. Atmospheric or other causes will frequently produce elongation or contraction of the belt which communicates motion to the machine, and the common way of remedying this difficulty is taking up or letting out the belt. To remove the difficulty of correcting this inequality, I have placed the screw R, and its thumb-nut, beneath my frame A. The screw passes through a slot in the table, which permits the machine to be moved sideways so as to increase or diminish the distance between the centres of the wheels C and D. The thumb-nut and screw R clamp the machine firmly to the table at any point desired. By these means the adjustment of the belt is made very quickly, and with the utmost nicety.

Having described my invention, what I claim as new, and desire to secure by Letters Patent, is—

1. The looping hook E, when arranged in a sewing machine having a reversible feed, so as to move in a plane at right angles to the line of feed, and so timed to the movement of the needle that the two will operate in proper relation to each other, without regard to the direction in which the feed is moving.
2. The combination of the driving-wheel D and pulley C of a sewing machine, when they are arranged so that the distance between them may be varied by sliding the machine sideways upon its table, and securing it by the devices shown.
3. The adjustable tension cylinder O, constructed and operating substantially as set forth.
4. The combination of the eccentric groove in the pulley L, the ring M fitted loosely in the said groove, and the pin N, through which the needle arm is actuated.
5. In combination with a rectilinear feeding dog of a sewing machine, the tapering notched lever J, and eccentric pin I, substantially as and for the purpose set forth.

W. B. BARTRAM.

Witnesses:

W. F. TAYLOR,  
A. G. CROSBY.