

FOR THE PURPOSES OF INFORMATION ONLY

Codes used to identify States party to the PCT on the front pages of pamphlets publishing international applications under the PCT.

AL	Albania	ES	Spain	LS	Lesotho	SI	Slovenia
AM	Armenia	FI	Finland	LT	Lithuania	SK	Slovakia
AT	Austria	FR	France	LU	Luxembourg	SN	Senegal
AU	Australia	GA	Gabon	LV	Latvia	SZ	Swaziland
AZ	Azerbaijan	GB	United Kingdom	MC	Monaco	TD	Chad
BA	Bosnia and Herzegovina	GE	Georgia	MD	Republic of Moldova	TG	Togo
BB	Barbados	GH	Ghana	MG	Madagascar	TJ	Tajikistan
BE	Belgium	GN	Guinea	MK	The former Yugoslav Republic of Macedonia	TM	Turkmenistan
BF	Burkina Faso	GR	Greece	ML	Mali	TR	Turkey
BG	Bulgaria	HU	Hungary	MN	Mongolia	TT	Trinidad and Tobago
BJ	Benin	IE	Ireland	MR	Mauritania	UA	Ukraine
BR	Brazil	IL	Israel	MW	Malawi	UG	Uganda
BY	Belarus	IS	Iceland	MX	Mexico	US	United States of America
CA	Canada	IT	Italy	NE	Niger	UZ	Uzbekistan
CF	Central African Republic	JP	Japan	NL	Netherlands	VN	Viet Nam
CG	Congo	KE	Kenya	NO	Norway	YU	Yugoslavia
CH	Switzerland	KG	Kyrgyzstan	NZ	New Zealand	ZW	Zimbabwe
CI	Côte d'Ivoire	KP	Democratic People's Republic of Korea	PL	Poland		
CM	Cameroon	KR	Republic of Korea	PT	Portugal		
CN	China	KZ	Kazakstan	RO	Romania		
CU	Cuba	LC	Saint Lucia	RU	Russian Federation		
CZ	Czech Republic	LI	Liechtenstein	SD	Sudan		
DE	Germany	LK	Sri Lanka	SE	Sweden		
DK	Denmark	LR	Liberia	SG	Singapore		
EE	Estonia						

HIGH-ENERGY ELECTROLYTIC CAPACITORS FOR IMPLANTABLE DEFIBRILLATORS

Background of the Invention

The present invention concerns electrolytic capacitors, particularly those for use in medical devices, such as implantable defibrillators.

Every year more than half a million people in the United States suffer
5 from heart attacks, more precisely cardiac arrests. Many of these cardiac arrests stem from the heart chaotically twitching, or fibrillating, and thus failing to rhythmically expand and contract as necessary to pump blood. Fibrillation can cause complete loss of cardiac function and death within minutes. To restore normal heart contraction and expansion, paramedics and other medical workers
10 use a device, called a defibrillator, to electrically shock a fibrillating heart.

Since the early 1980s, thousands of patients prone to fibrillation episodes have had miniature defibrillators implanted in their bodies, typically in the left breast region above the heart. These implantable defibrillators detect onset of fibrillation and automatically shock the heart, restoring normal heart function
15 without human intervention. A typical implantable defibrillator includes a set of electrical leads, which extend from a sealed housing into the heart of a patient after implantation. Within the housing are a battery for supplying power, heart-monitoring circuitry for detecting fibrillation, and a capacitor for storing and delivering a burst of electric charge through the leads to the heart.

20 The capacitor is typically an aluminum electrolytic capacitor, which usually includes a sandwich-like assembly of two strips of aluminum foil with two strips of paper, known as separators, between them. One of the aluminum foils serves as a cathode (negative) foil, and the other serves as an anode (positive) foil. Sometimes, two foils are stacked one on the other to form a dual
25 anode. Attached to each foil is an aluminum tab which electrically connects the foil to other parts of the capacitor.

The foil-and-paper assembly, known as an active element, is then placed in a case, usually made of aluminum, and the paper is soaked, or impregnated, with a liquid electrolyte ---a very electrically conductive solution containing free
30 positive or negative ions. After the paper is impregnated, the case is sealed shut

with a lid called a header. Extending from the header are two terminals connected respectively to the anode foil and cathode foil via the aluminum tabs.

In recent years, manufacturers of aluminum electrolytic capacitors have improved capacitor performance through the development of aluminum foils with increased surface areas. Increasing surface area of a foil, particularly the anode foil, increases capacitance and thus the charge-storage capacity of a capacitor.

One approach to increasing surface area of a foil is to chemically etch microscopic hills and valleys into both sides of the foil. The etching depth is controlled to leave a solid core layer between the sides of the foil. Thus, foils with this type of etching are called "core etched." Although core-etched foils have more surface area, they don't work as well as expected in capacitors with two stacked anode foils, because the solid core layer of one anode foil shields the other anode foil from electrolyte flow.

Another approach, known as tunnel etching, entails etching both sides of a foil to form millions of tiny holes, or tunnels, completely through the foil, from one side to the other. The tunnels, which typically have an approximately circular cross-section about one-micron in diameter, allows electrolyte to flow through the foil. Thus, tunnel-etched foils overcome the electrolyte-flow problem of core-etched foils.

However, tunnel-etched foils not only have less surface area than core-etched foils but are also quite brittle and tend to break easily, particularly when rolling or winding the foils to form cylindrical capacitors. Accordingly, there remains a need to develop more durable foil structures.

Summary of the Invention

To address these and other needs, the present inventors devised a new foil structure which combines the durability of core-etched foils with the electrolyte-flow advantages of tunnel-etched foils. In addition to devising methods for making the new foil structure, the inventors applied the new foil structure in novel ways to build new capacitor foil assemblies and new capacitors in cylindrical and flat configurations, for example. Ultimately, these advances allow construction of smaller medical devices, such as implantable defibrillators.

Specifically, one embodiment of the new foil structure is a foil having one or more holes or perforations and one or more cavities with a depth less than the foil thickness. In an exemplary embodiment, each perforation and cavity has a cross-sectional area, with the perforations having a larger, for example, 2 to 5 100 times larger, average cross-sectional area than the cavities. One method of making the new foil structure includes perforating a foil and forming cavities into one or both of its surfaces. Other methods form the cavities before perforating the foil.

Brief Description of the Drawings

10 Figure 1 is an enlarged perspective view of an exemplary foil structure 8 that embodies the invention;

Figure 2 is a perspective view of an exemplary cylindrical electrolytic capacitor 10 which incorporates the foil structure of Figure 1;

Figure 3 is a cross-sectional view of an exemplary electrolytic capacitor 15 10 which incorporates the foil structure of Figure 1;

Figure 4 is a cross-sectional view of a layered capacitive assembly 21 which forms an active element 20 of capacitor 10 and which incorporates the Figure 1 foil structure;

Figures 5A-5C are perspective views of other capacitor configurations 20 that incorporate the Figure 1 foil structure;

Figure 6 is a cross-sectional view of a symmetric capacitive assembly 60 which incorporates the Figure 1 foil structure and which is particularly suited for flat capacitor configurations; and

Figure 7 is a block diagram of generic implantable defibrillator 70 25 including a capacitor that incorporates the Figure 1 foil structure.

Detailed Description

The following detailed description, which references and incorporates Figures 1-7, describes and illustrates one or more exemplary embodiments of the invention, specifically a new foil structure and method of manufacture, several 30 new foil assemblies, new capacitors incorporating the foil structure and foil assemblies, and an implantable defibrillator incorporating one or more of the new capacitors. These embodiments, offered not to limit but only to exemplify and teach, are shown and described in sufficient detail to enable those skilled in

the art to implement or practice the invention. Thus, where appropriate to avoid obscuring the invention, the description may omit certain information known to those of skill in the art.

Exemplary Foil Structure and Methods of Manufacture

5 Figure 1 shows an enlarged perspective view of a foil structure 8 which the inventors call a “perforated-core-etched” foil. Foil structure 8 can be made of aluminum, tantalum, hafnium, niobium, titanium, zirconium, and combinations of these metals. However, the invention is not limited to any particular foil composition or class of foil compositions.

10 Foil structure 8 includes opposing surfaces 8a and 8b which define an average foil thickness $8t$ and a set of perforations 8p which extend through foil structure 8 from surface 8a to surface 8b. Surfaces 8a and 8b include respective sets of surface cavities (or depressions) 9a and 9b, which have generally cylindrical, conical, or hemispherical shapes. However, the invention is not
15 limited to any particular cavity form, class of cavity forms, or combination of cavity forms. Surface cavities 9a have an average maximum depth D_a which is less than thickness $8t$, and surface cavities 9b having an average maximum depth D_b which is also less than thickness $8t$. As Figure 1 shows, depths D_a and D_b are measured along dimensions generally perpendicular to respective surfaces 8a
20 and 8b. Cavities 9a and 9b also have respective average maximum cross-sectional areas S_a and S_b (which are not shown in the figure.) Cross-sectional area is measured in a plane substantially parallel to one of surfaces 8a and 8b.

In the exemplary embodiment, average maximum depths D_a and depths D_b are approximately equal to one third or one quarter of thickness $8t$, and cross-
25 sectional areas S_a and S_b are substantially equal and range inclusively between about 0.16 and 0.36 square-microns. However, other embodiments use different equal and unequal depths D_a and D_b and different and unequal cross-sectional areas S_a and S_b .

More generally, the exemplary embodiment adheres to the constraint that
30 the sum of average maximum depths D_a and D_b is less than thickness $8t$. Adherence to this constraint ensures that a significant number of cavities 9a are separated from a significant number of cavities 9b by a solid region of foil material. These regions of solid material not only provide foil structure 8 with

greater structural integrity but also greater surface area than conventional tunnel-etched foils. However, in some embodiments of the invention, one or more of cavities 9a intersect one or more of cavities 9b, thereby forming openings through the foil. The number of these intersections and resultant openings can
5 be regulated through selection of appropriate cavity formation techniques and cavity depths.

In addition to surface cavities 9a and 9b, Figure 1 shows that foil structure 8 includes a set of one or more perforations (or holes) 8p. Perforations 8p have an average maximum cross-sectional area S_p measured in a plane
10 substantially parallel to one of surfaces 8a and 8b. Although perforations 8p have a generally circular cross-section in the exemplary embodiment, other embodiments use perforations with elliptical, triangular, square, or rectangular cross-sections. Thus, the invention is not limited to any particular shape or class of shapes. The layout or arrangement of perforations 8p takes any number of
15 forms, including for example, a random distribution and a specific pattern with each perforation having a predetermined position relative to other perforations. The number of perforations per unit area is chosen to optimize relevant criteria, such as capacitor electrical performance or foil structural properties.

In the exemplary embodiment, average maximum cross-sectional area S_p
20 of perforations 8p is larger than average maximum cross-sectional areas S_a and S_b of cavities 9a and 9b. More precisely, area S_p in the exemplary embodiment ranges between about 500 square-microns and 32 square-millimeters. In other embodiments, area S_p ranges between 2-50, 10-75, 25-100, or 2-100 times larger than surface areas S_a and S_b . Additionally, the exemplary embodiment provides
25 a total perforation area (number of perforations times average maximum cross-sectional area S_p) which is no more than about 20 percent of the foil surface area.

The inventors have devised a number of ways of making foil structure 8. For example, one method initially core-etches a foil using conventional etching
30 techniques to form cavities 9a and 9b and then perforates the core-etched foil. Another method entails initially perforating a foil to form perforations 8p and then etching the perforated foil to form cavities 9a and 9b. (For more details on a conventional etching technology, see, for example, U.S. Patent 4,395,305 to

Whitman, which is entitled Chemical Etching of Aluminum Capacitor Foil and incorporated herein by reference.) Perforations 8p can be formed using lasers, chemical etchants, or mechanical dies, for example. Conceptually, cavities 9a and 9b could also be formed using lasers. Thus, the invention is not limited to any particular technique or combination of techniques for forming perforations 8p and cavities 9a and 9b.

In one embodiment of the invention, further processing of the foils, particularly those intended for electrolytic capacitors, entails applying an insulative, or dielectric, coating to one or both sides of the foils. Examples of suitable coatings include metallic oxides such as aluminum or tantalum oxide.

Exemplary Foil Assemblies Incorporating the New Foil Structure

Foil structure 8 can be combined with other foils structures to form various electrically and/or mechanically advantageous foil assemblies. Many of these assemblies are particularly useful as multiple anodes structures in flat, semi-cylindrical, and cylindrical capacitors.

In particular, the inventors devised several foil assemblies that combine foil structure 8 with core-etched and tunnel-etched foils. For example, one foil assembly stacks two or three foils incorporating foil structure 8 to form a dual- or triple-foil assembly which can serve as a dual or triple anode. Another foil assembly stacks a core-etched foil between two foils incorporating foil structure 8. Table 1 describes these and several other foil assemblies.

Table 1

	<u>Foil Assembly No.</u>	<u>Structure</u>
	1	PP
25	2	PPP
	3	PCP
	4	PPCPP
	5	PTP
	6	PTPT
30	7	TPT
	8	PTCTP

In the table, P denotes a perforated foil similar to foil structure 8; C denotes a core-etched foil; and T denotes a tunnel-etched foil. Thus, for example, foil assembly 7 comprises a foil similar to foil structure 8 between two tunnel-etched foils. Other novel assemblies result from combining two or more of these assemblies. For instance, combining two assembly 1s yields a PPPP

structure, and combining assemblies 2 and 3 yields a PPPPCP structure. Additionally, still other novel assemblies result from inserting insulators and electrolyte-impregnated substrates, such as paper, between adjacent foils of an assembly.

5 Exemplary Capacitor Incorporating the New Foil Structure

Figure 2 shows a perspective view of an exemplary electrolytic capacitor 10 which incorporates one or more foils incorporating foil structure 8 or one or more of the foil assemblies described above. In addition to incorporating these novel foils and foil assemblies, capacitor 10 embodies many novel space-saving 10 features. These features and their advantages are addressed in a co-pending U.S. Patent application (attorney docket number 279.086US1) which is entitled Smaller Electrolytic Capacitors for Implantable Defibrillator, and which was filed on the same day as the present application. This application is incorporated herein by reference.

15 More specifically, Figure 2 shows that capacitor 10 has a diameter 10d of about 14.5 millimeters and a total height 10h of about 30 millimeters, thereby occupying a total volume of about five cubic-centimeters. Capacitor 10 also includes a cylindrical aluminum case 12, a header (or lid) 14, and two aluminum terminals 16 and 18. Two rivets 15 and 17 fasten terminals 16 and 18 to header 20 14. Case 12, which houses an active element 20 (not visible in this view), includes a circumferential seating groove 12a and a rolled lip 12b, both of which secure header 14 to case 12.

Figure 3, a cross-sectional view taken along line 3-3 in Figure 2, shows that case 12 has a thickness 12t and groove 12a is spaced a distance 12d from lip 25 12b. Thickness 12t is about 0.010 inches, and distance 12d is about 0.145 inches. Additionally, groove 12a has a radius of about 0.035 inches, and lip 12b, which is formed by rolling over the top edge of case 12, has a radius of about 0.015 inches. (Some embodiments compress or flatten groove 12a to reduce capacitor height and volume.) Header 14, which comprises a rubber layer 30 14a and a phenolic-resin layer 14b, has a total thickness 14t of about two millimeters.

Figure 3 also shows that capacitor 10 includes an active element 20 wound around mandrel region 28 and two pairs of insulative inserts 30a-30b and

32a-32b respectively positioned adjacent the top and bottom of active element 20. Mandrel region 28 has an exemplary width or diameter 28w of about 2.5 millimeters. And, insulative inserts 30a-30b and 32a-32b comprise respective pairs of paper disks, with each disk having a thickness of one one-thousandth of an inch and a diameter of about 14 millimeters. The insulative inserts ensure electrical isolation of conductive portions of active element 20 from anode tab 25 and rivets 15 and 17 and from the bottom interior surface of case 12. (As an alternative to insulative inserts, other embodiments enclose substantially all of active element 20 within an insulative bag.) For clarity, Figure 3 omits a 1.125-
5
10 inch-wide plastic insulative sheath that surrounds the vertical surfaces of active element 20.

Active element 20 comprises about 19 turns of a layered capacitive assembly 21. As the cross-section in Figure 4 shows, capacitive assembly 21 includes a cathode 22, an anode structure 24, and four electrolyte-impregnated
15 separators 26a, 26b, 26c, and 26d. Cathode 22 and anode 24 each have a width (or height) 22w. In this exemplary embodiment, cathode 22 and the one or more constituents of anode structure 24 are about 24 millimeters wide and 100 microns thick. Cathode 22 is about 422 millimeters long, and anode structure 24 is about 410 millimeters long.

20 Anode structure 24 can assume a variety of novel forms, the simplest being a single foil member incorporating foil structure 8 of Figure 1. Some embodiments provide anode structure 24 with one or more of the novel foil assemblies described using Table 1.

Although not shown in Figure 4, the exemplary embodiment connects
25 anode structure 24 to one anode tab regardless of the number of foils constituting the anode structure. (Figure 3 shows an exemplary aluminum anode tab 25.) Other embodiments, however, provide individual anode tabs for each anode members, with the tabs connected together to form a joint or composite anode tab. For more details on these or other types of tabs incorporated in other
30 embodiments of the invention, see co-pending U.S. patent applications 09/063692 and 09/076023 (attorney docket numbers 279.094US1 and 279.101US1) which are respectively entitled Electrolytic Capacitor and Multi-

Anodic Attachment and Wound Multi-Anode Electrolytic Capacitor with Offset Anodes and which are incorporated herein by reference.

Anode tab 25, shown in Figure 3, is ultrasonically welded to rivet 15 and thus electrically connected to terminal 16. The exemplary embodiment folds anode tab 25 over itself; however, other embodiments omit this fold to reduce the space between header 14 and the top of active element 20. Though not visible in Figure 3 or 4, cathode 22 includes a cathode tab which is similarly connected via rivet 17 to terminal 18.

In addition to cathode 22 and anode 24, Figure 4 shows that capacitive assembly 21 includes thin electrolyte-impregnated separators 26, specifically 26a, 26b, 26c, and 26d. In the exemplary embodiment, separators 26a-26d each consists of kraft paper impregnated with an electrolyte, such as an ethylene-glycol base combined with polyphosphates or ammonium pentaborate, and each has a thickness less than 0.001 inches. More specifically, the exemplary embodiment uses one or more papers of the following thicknesses: 0.000787, 0.0005 inches, and 0.00025 inches, with thicker papers preferably placed nearer the center of the active element to withstand the greater tensile stress that interior separators experience during winding.

Additionally, each of separators 26a-26d has a width 26w which is less than four millimeters wider than cathode 22 and anode 24 to provide end margins 27a and 27b. In the exemplary embodiment, width 26w is about 27 millimeters, or three millimeters wider than cathode 22 and anode 24, to provide end margins 27a and 27b of about 1.5 millimeters. Other embodiments of the invention provide at least one end margins of about 1.75, 1.25, 1, 0.75, 0.5, 0.25, and even 0.0 millimeters.

Although the exemplary capacitor 10 has a wound or cylindrical configuration, the invention is not limited to any particular type or category of configurations. For example, Figures 5A, 5B, and 5C show other capacitor configurations encompassed by the invention. More specifically, Figure 5A shows a semi-cylindrical (or "D") capacitor; Figure 5B shows an asymmetric semi-cylindrical capacitor; and Figure 5C shows a flat (or more precisely a rectangular parallelepiped) capacitor. Figure 6 show a cross-sectional view of a

capacitive assembly 60 particularly useful for flat capacitors such as the one shown in Figure 5C.

In particular, capacitive assembly 60 includes an anode structure 62 between two cathode foils 64a and 64b. Electrolyte-impregnated separators 63a and 63b lie respectively between anode structure 62 and cathode foils 64a and 64b. In the exemplary embodiment separators 63a and 63b each comprise two or more layers of kraft paper of thicknesses similar to separators 26 of Figure 4. Anode structure 62 comprises one or more of the foil assemblies identified in Table 1.

10

Exemplary Embodiment of Implantable Defibrillator

Figure 7 shows one of the many applications for exemplary capacitor 10: a generic implantable defibrillator 70. More specifically, defibrillator 70 includes a lead system 72, which after implantation electrically contacts strategic portions of a patient's heart, a monitoring circuit 74 for monitoring heart activity through one or more of the leads of lead system 72, and a therapy circuit 76 which delivers electrical energy through lead system 72 to the patient's heart. Therapy circuit 76 includes an energy storage component 76a which incorporates at least one capacitor having one or more of the novel features of capacitor 10. Defibrillator 70 operates according to well known and understood principles.

20

In addition to implantable defibrillators, the innovations of capacitor 10 can be incorporated into other cardiac rhythm management systems, such as heart pacers, combination pacer-defibrillators, and drug-delivery devices for diagnosing or treating cardiac arrhythmias. They can be incorporated also into non-medical applications, for example, photographic flash equipment. Indeed, the innovations of capacitor 10 are pertinent to any application where small, high energy, low equivalent-series-resistance (ERS) capacitors are desirable.

25

Conclusion

In furtherance of the art, the inventors devised a new foil structure which combines the durability of core-etched foils with the electrolyte flow advantages of tunnel-etched foils. In addition to devising methods for making the new foil structure, the inventors applied the new foil structure to build new capacitors and implantable defibrillators.

30

The embodiments described above are intended only to illustrate and teach one or more ways of practicing or implementing the present invention, not to restrict its breadth or scope. The actual scope of the invention, which embraces all ways of practicing or implementing the concepts and principles of the invention, is defined only by the following claims and their equivalents.

CLAIMS

1. A foil having a foil thickness and comprising:
one or more perforations and one or more cavities having a depth less than the foil thickness.
2. The foil of claim 1 wherein the foil has first and second opposing sides, with one or more of the cavities on the first side and one or more of the cavities on the second side and wherein the average depth of the cavities is less than one-half the foil thickness.
3. The foil of claim 2 wherein the average depth of the cavities is about one-third or one-fourth of the foil thickness.
4. The foil of claim 1 wherein the perforations have an average cross-sectional area larger than an average cross-sectional area of the cavities.
5. The foil of claim 4 wherein the average cross-sectional area of the perforations is about 2 to 100 times larger than the average cross-sectional area of the cavities.
6. The foil of claim 1 wherein each perforations has a generally circular cross-section.
7. The foil of claim 1 wherein the foil comprises at least one of aluminum, tantalum, hafnium, niobium, titanium, and zirconium.
8. The foil of claim 1 wherein one or more of the cavities define a perimeter which circumscribes one or more of the perforations and wherein the foil is at least partly rolled.
9. A foil for a capacitor, comprising:
first and second opposing surfaces which define a foil thickness, with the first opposing surface having one or more cavities each having a

maximum depth less than the foil thickness and the second opposing surface having one or more cavities each having a maximum depth less than the foil thickness: and one or more perforations through the foil.

10. The foil of claim 9 wherein the cavities of the first surface have a first average maximum depth and the cavities of the second surface have a second average maximum depth, with the first and second average maximum depths being less than one-half the foil thickness.
11. The foil of claim 9 wherein the perforations have an average cross-sectional area at least twice an average cross-sectional area of the cavities.
12. An aluminum foil for a capacitor, comprising:
first and second opposing surfaces which define a foil thickness, with the first opposing surface having one or more cavities and the second opposing surface having one or more cavities, the cavities of the first and second surfaces having an average depth less than one half the foil thickness and having an average cross-sectional area;
and
one or more perforations through the foil, with the perforations having an average cross-sectional area at least twice the average cross-sectional area of the cavities.
13. The aluminum foil of claim 12:
wherein the average depth of the cavities is about one-third or one-fourth of the foil thickness; or
wherein the perforations have an average cross-sectional area about 2 to 100 times larger than the average cross-sectional area of the cavities.

14. A foil assembly comprising:
two or more foils stacked according to one or more of the following foil sequences: PP, PPP, PCP, PPCPP, PTP, PTPT, TPT, PTCTP, wherein C denotes a core-etched foil; T denotes a tunnel-etched foil; and P denotes a foil having a foil thickness and comprising one or more perforations and one or more cavities having a depth less than the foil thickness.

15. The foil assembly of claim 14:
wherein each P foil has first and second opposing sides, with one or more of the cavities on the first side and one or more of the cavities on the second side and wherein the average depth of the cavities is less than one-half the foil thickness; or
wherein the perforations have an average cross-sectional area larger than an average cross-sectional area of the cavities; or
wherein the average cross-sectional area of the perforations is about 2 to 100 times larger than an average maximum cross-sectional area of the cavities; or
wherein one or more the foils comprises at least one of aluminum, tantalum, hafnium, niobium, titanium, and zirconium.

16. A capacitor comprising:
a foil having a foil thickness;
one or more perforations;
and one or more cavities having a depth less than the foil thickness.

17. The capacitor of claim 16 wherein the foil has first and second opposing sides, with one or more of the cavities on the first side and one or more of the cavities on the second side and wherein the average depth of the cavities is less than one-half the foil thickness.

18. The capacitor of claim 17 wherein the average depth of the cavities is about one-third or one-fourth of the foil thickness.

19. The capacitor of claim 16:
wherein the perforations have an average cross-sectional area larger than
an average cross-sectional area of the cavities; or
wherein the perforations have generally circular cross-sections; or
wherein the foil comprises at least one of aluminum, tantalum, hafnium,
niobium, titanium, and zirconium.
20. The capacitor of claim 16 wherein at least a portion of the foil is rolled.
21. The capacitor of claim 16 wherein the foil is part of an anode structure.
22. A capacitor comprising:
a foil having first and second opposing surfaces which define a foil
thickness, with the first opposing surface having one or more
cavities each having a maximum depth less than the foil thickness
and the second opposing surface having one or more cavities each
having a maximum depth less than the foil thickness; and
one or more perforations through the foil.
23. The capacitor of claim 22:
wherein the cavities of the first surface have a first average depth and the
cavities of the second surface have a second average depth, with
the first and second average depths being less than one-half the
foil thickness; or
wherein the perforations have an average cross-sectional area at least
twice an average maximum cross-sectional area of the cavities; or
wherein at least a portion of the foil is rolled.
24. An aluminum electrolytic capacitor comprising:
at least one aluminum anode foil having first and second opposing
surfaces which define a foil thickness, with the first opposing
surface having one or more cavities and the second opposing
surface having one or more cavities, the cavities of the first and

second surfaces having an average maximum depth less than one half the foil thickness and having an average maximum cross-sectional area; and

one or more perforations through the aluminum anode foil, with the perforations having an average maximum cross-sectional area at least twice the average maximum cross-sectional area of the cavities.

25. The aluminum electrolytic capacitor of claim 24:
wherein the average depth of the cavities is about one-third or one-fourth the foil thickness; or
wherein the perforations have an average maximum cross-sectional area about 2 to 100 times larger than the average maximum cross-sectional area of the cavities.
26. A capacitor comprising:
at least one perforated-core-etched foil; or
at least one perforated-core-etched foil adjacent at least one core-etched foil; or
at least one perforated-core-etched foil, at least one core-etched foil; and
at least one tunnel-etched foil.
27. The capacitor of claim 26 wherein each perforated core-etched foil comprises:
first and second opposing surfaces which define a foil thickness, with the first opposing surface having one or more cavities each having a maximum depth less than the foil thickness and the second opposing surface having one or more cavities each having a maximum depth less than the foil thickness; and
one or more perforations through the foil.
28. The capacitor of claim 27 wherein the cavities of the first surface have a first average depth and the cavities of the second surface have a second average

depth, with the first and second average depths being less than one-half the foil thickness.

29. A capacitor comprising one or more tunnel-etched foils between two or more perforated-core-etched foils.

30. A medical device comprising:
one or more leads for sensing electrical signals of a patient or for applying electrical energy to the patient;
a monitoring circuit for monitoring heart activity of the patient through one or more of the leads; and
a therapy circuit for delivering electrical energy through one or more of the leads to a heart of the patient, wherein the therapy circuit includes one or more capacitors which include a foil that comprises:
first and second opposing surfaces which define a foil thickness, with the first opposing surface having one or more cavities each having a maximum depth less than the foil thickness and the second opposing surface having one or more cavities each having a maximum depth less than the foil thickness; and
one or more perforations through the foil.

31. The medical device of claim 30 wherein the cavities of the first surface have a first average maximum depth and the cavities of the second surface have a second average maximum depth, with the first and second average maximum depths being less than one-half the foil thickness.

32. A method of processing a foil, the method comprising:
perforating a foil having a foil thickness; and
forming one or more surface cavities in the foil, the surface cavities having an average depth less than the foil thickness.

33. The method of claim 32, wherein perforating the foil occurs after forming the one or more surface cavities.

34. The method of claim 32 wherein the foil has first and second opposing sides and forming one or more surface cavities in the foil comprises forming one or more of the cavities on the first side and one or more of the cavities on the second side, with the cavities having an average depth less than one-half the foil thickness.

35. The method of claim 32 wherein the average depth of the cavities is about one-third or one-fourth of the foil thickness.

36. The method of claim 32 wherein forming the perforations or forming the cavities comprising using electromagnetic, chemical, or mechanical energy.

37. The method of claim 32 wherein the foil comprises at least one of aluminum, tantalum, hafnium, niobium, titanium, and zirconium.

38. A method of making a perforated-core-etched foil for a capacitor, the method comprising:

forming one or more holes in a core-etched foil; or

forming one or more surface cavities in a perforated foil having a foil thickness, with the surface cavities having an average depth less than the foil thickness.

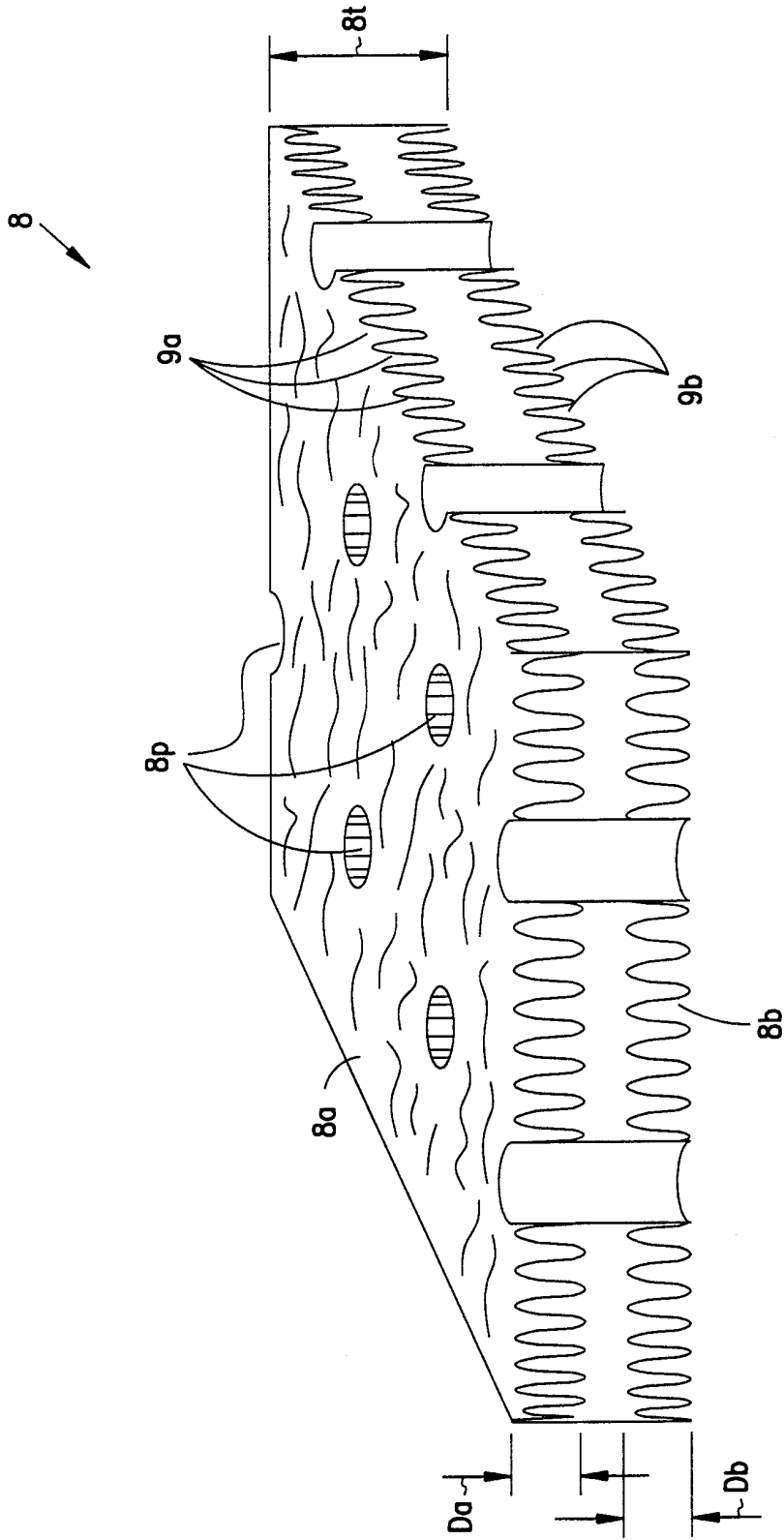

FIG. 1

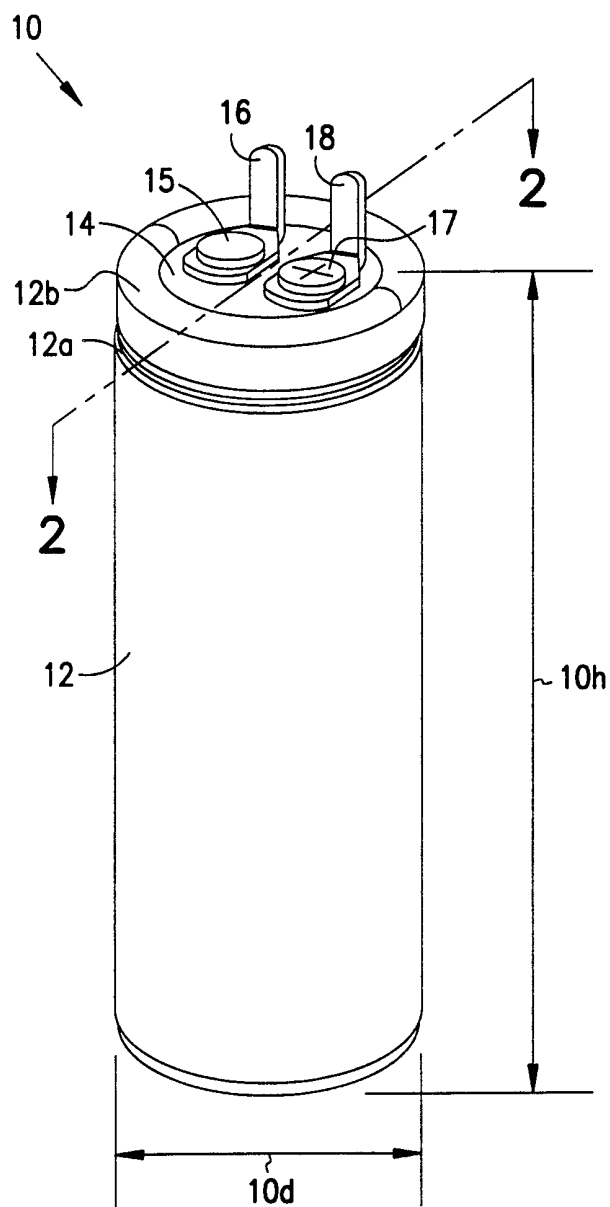

FIG. 2

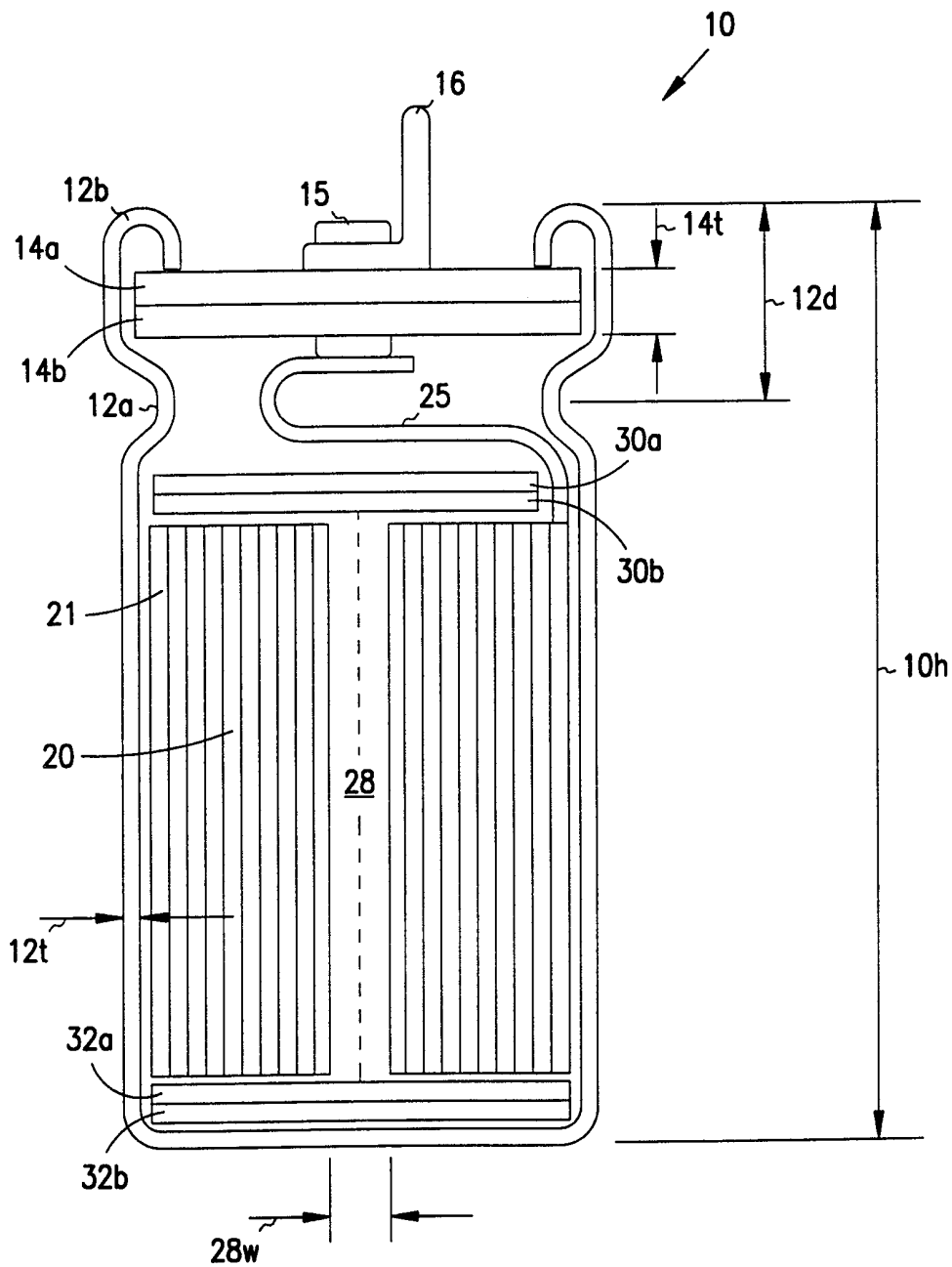

FIG. 3

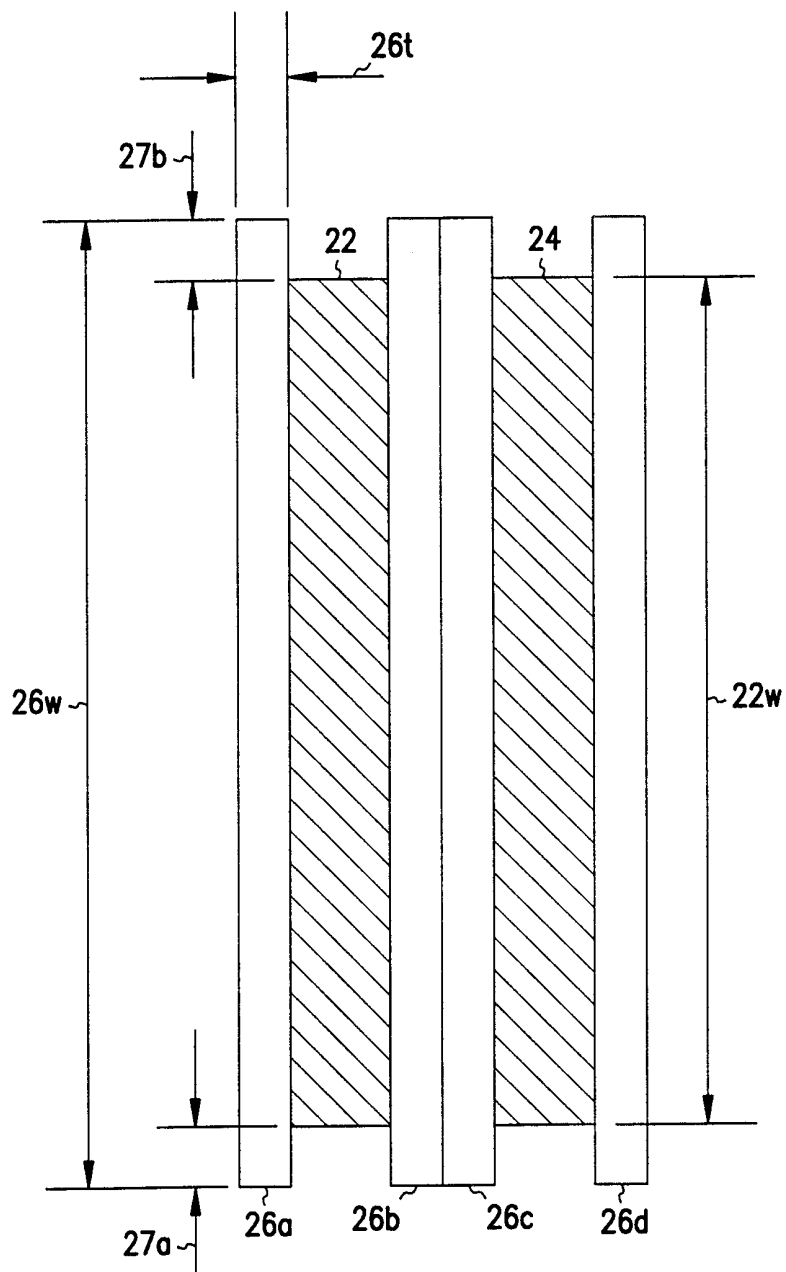

FIG. 4

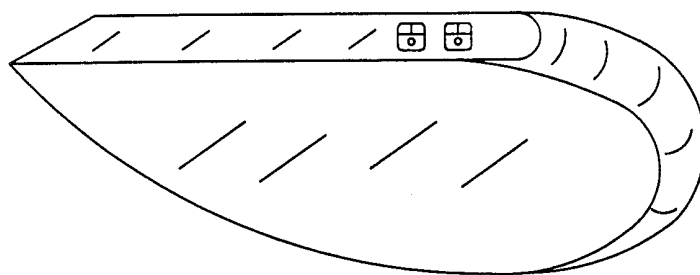

FIG. 5A

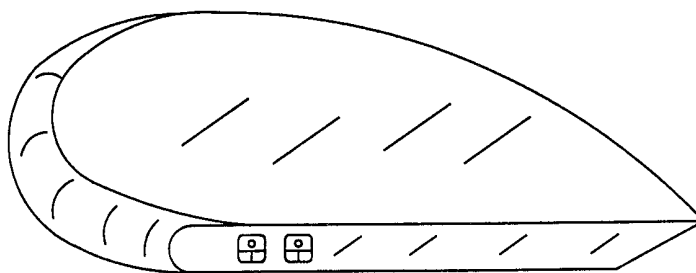

FIG. 5B

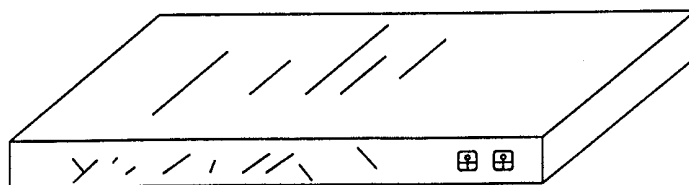

FIG. 5C

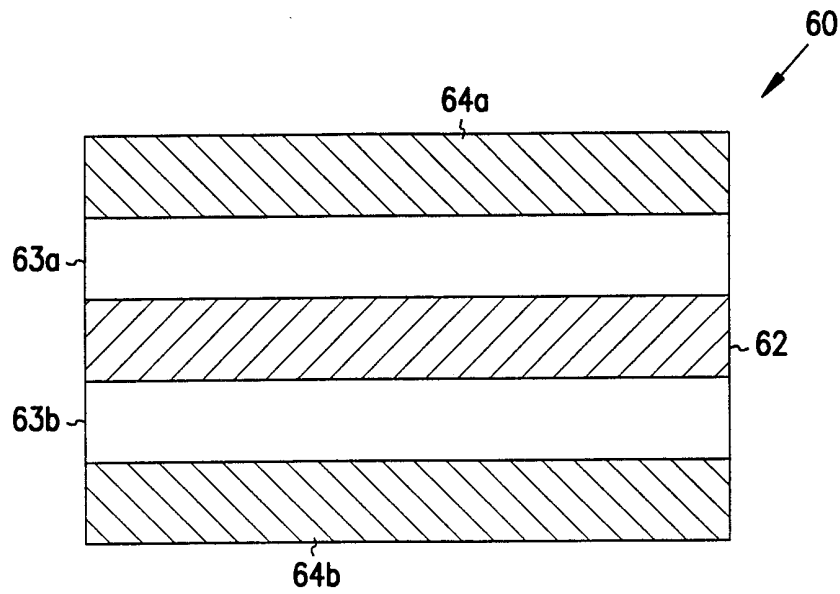

FIG. 6

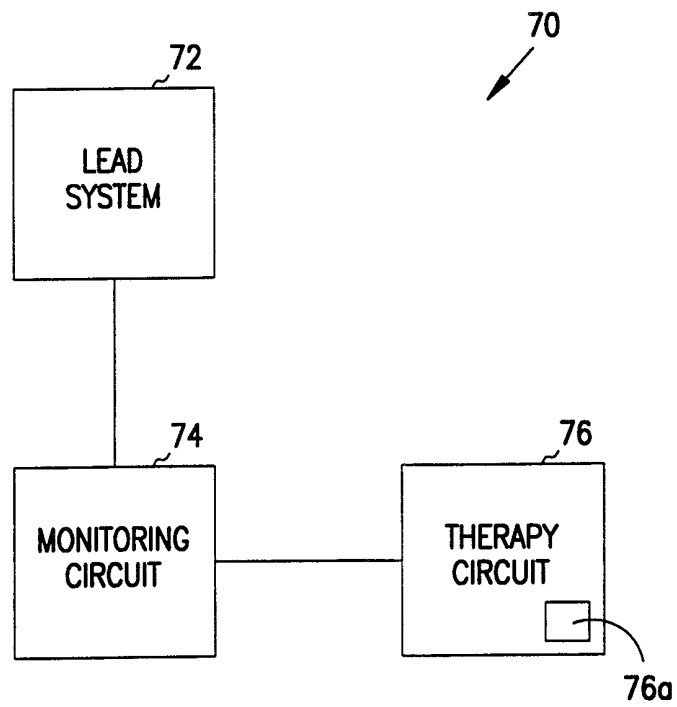

FIG. 7

INTERNATIONAL SEARCH REPORT

International Application No
PCT/US 99/22552

C.(Continuation) DOCUMENTS CONSIDERED TO BE RELEVANT

Category	Citation of document, with indication, where appropriate, of the relevant passages	Relevant to claim No.
A	US 5 697 953 A (KROLL MARK W ET AL) 16 December 1997 (1997-12-16) the whole document -----	30

INTERNATIONAL SEARCH REPORT

Information on patent family members

Int. Patent Application No

PCT/US 99/22552

Patent document cited in search report	Publication date	Patent family member(s)	Publication date
EP 0753868 A	15-01-1997	DE 19525143 A	16-01-1997
		US 5822177 A	13-10-1998
EP 0851446 A	01-07-1998	JP 10189398 A	21-07-1998
		SG 65713 A	22-06-1999
US 5697953 A	16-12-1997	US 5827326 A	27-10-1998
		US 5405363 A	11-04-1995
		US 5957956 A	28-09-1998
		CA 2117772 A	06-01-1994
		DE 69320474 D	24-09-1998
		DE 69320474 T	11-03-1999
		EP 0642369 A	15-03-1995
		JP 8509385 T	08-10-1996
		WO 9400193 A	06-01-1994
		US 5439482 A	08-08-1995