



(51) International Patent Classification:

A47C 7/00 (2006.01) A47C 27/06 (2006.01)  
A47C 7/34 (2006.01) A47C 27/07 (2006.01)  
A47C 27/00 (2006.01) B68G 9/00 (2006.01)

(21) International Application Number:

PCT/US2020/013781

(22) International Filing Date:

16 January 2020 (16.01.2020)

(25) Filing Language:

English

(26) Publication Language:

English

(30) Priority Data:

16/351,621 13 March 2019 (13.03.2019) US

(71) Applicant: **L&P PROPERTY MANAGEMENT COMPANY** [US/US]; 4095 Firestone Boulevard, South Gate, CA 90280 (US).

(72) Inventors: **JEWETT, Jason**; 7777 County Road 110, Carthage, MO 64836 (US). **RICHMOND, Darrell, A.**; 8151 County Road 164, Carthage, MO 64836 (US).

**ROBERTSON, Shaw, F.**; 25435 Tabor Main Road, Joplin, MO 64801 (US).

(74) Agent: **POFFENBERGER, J., Dwight** et al.; Wood Heron & Evans LLP, 441 Vine Street, Suite 2700, Cincinnati, OH 45202-2917 (US).

(81) Designated States (unless otherwise indicated, for every kind of national protection available): AE, AG, AL, AM, AO, AT, AU, AZ, BA, BB, BG, BH, BN, BR, BW, BY, BZ, CA, CH, CL, CN, CO, CR, CU, CZ, DE, DJ, DK, DM, DO, DZ, EC, EE, EG, ES, FI, GB, GD, GE, GH, GM, GT, HN, HR, HU, ID, IL, IN, IR, IS, JO, JP, KE, KG, KH, KN, KP, KR, KW, KZ, LA, LC, LK, LR, LS, LU, LY, MA, MD, ME, MG, MK, MN, MW, MX, MY, MZ, NA, NG, NI, NO, NZ, OM, PA, PE, PG, PH, PL, PT, QA, RO, RS, RU, RW, SA, SC, SD, SE, SG, SK, SL, ST, SV, SY, TH, TJ, TM, TN, TR, TT, TZ, UA, UG, US, UZ, VC, VN, WS, ZA, ZM, ZW.

(84) Designated States (unless otherwise indicated, for every kind of regional protection available): ARIPO (BW, GH, GM, KE, LR, LS, MW, MZ, NA, RW, SD, SL, ST, SZ, TZ, UG, ZM, ZW), Eurasian (AM, AZ, BY, KG, KZ, RU, TJ, TM), European (AL, AT, BE, BG, CH, CY, CZ, DE, DK, EE, ES, FI, FR, GB, GR, HR, HU, IE, IS, IT, LT, LU, LV,

(54) Title: COMFORT LAYER HAVING POCKETED SPRINGS OF DIFFERENT HEIGHTS

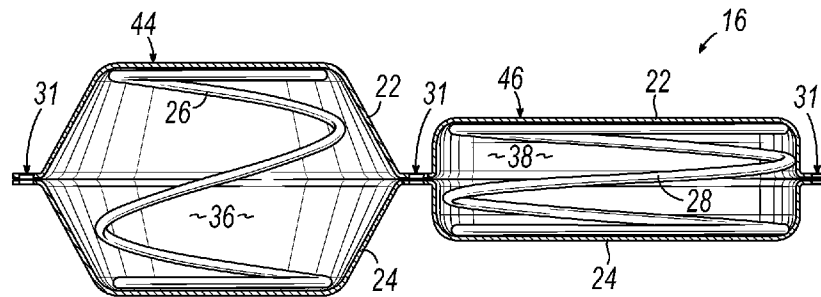

**FIG. 4A**

(57) Abstract: A posturized comfort layer (16, 16a, 16b, 16c, 16d, 16e, 16f, 16g, 16h, 16i, 16j, 16k, 16l, 16m) for a bedding or seating product (10, 10a) has different sections (40, 42, 40a, 42a, 70, 72, 40c, 42c, 40d, 42d, 94, 96, 40f, 42f, 98, 100, 102, 104, 106, 108, 40h, 42h) of different firmness due to different mini coil springs (26, 28, 52, 54, 60, 64, 80) within the sections. The springs (26, 28, 52, 54, 60, 64, 80) may be individually pocketed between two sheets of non-woven polypropylene fabric (22, 24) joined with circular or rectangular weld seams (30, 31, 74, 82, 88). Regardless of the shape of the weld seams (30, 31, 74, 82, 88), the different firmness of the different sections of the comfort layer may be due to different mini coil springs (26, 28, 52, 54, 60, 64, 80) contained in the pockets (36, 38). All pockets may have the same spring, the springs may be contained in different size weld seams to create pockets of different heights.



WO 2020/185302 A1

MC, MK, MT, NL, NO, PL, PT, RO, RS, SE, SI, SK, SM,  
TR), OAPI (BF, BJ, CF, CG, CI, CM, GA, GN, GQ, GW,  
KM, ML, MR, NE, SN, TD, TG).

**Published:**

— *with international search report (Art. 21(3))*

**COMFORT LAYER HAVING POCKETED SPRINGS OF DIFFERENT HEIGHTS****Technical Field of the Invention**

[0001] This invention relates to a comfort layer for bedding and seating products. More particularly, this invention relates to a pocketed spring comfort layer for use in seating or bedding products.

**Background of the Invention**

[0002] Comfort layers are commonly used in seating or bedding products above/below a core, which may or may not include a spring assembly. Such comfort layers may include foam, fiber and gel products. U.S. Patent No. 8,087,114 discloses a comfort layer made of pocketed springs. Such spring assemblies may be made of strings of individually pocketed coil springs joined together or multiple coil springs joined together by helical lacing wires.

[0003] Comfort layers comprising mini pocketed coil springs have heretofore been a uniform firmness throughout. The mini pocketed coil springs have all been the same.

[0004] One desirable feature of known pocketed spring assemblies used as the core of bedding products is posturized support, i.e., one or more sections of the pocketed spring assembly being firmer than another section or other sections of the pocketed spring assembly. Due to the configuration of the human body laying on a bedding or seating product, additional support in a middle or lumbar section of the product may be desirable. Comfort layers are commonly used in seating or bedding products above/below a central core. The central core may or may not include a spring assembly. The central core is most commonly a pocketed or un-pocketed spring core. However, the central core of a bedding or seating product may be made partially or entirely of foam.

[0005] U.S. Patent Nos. 9,968,202 and 9,943,173 each disclose a comfort layer made of pocketed mini coil springs configured to overlay a spring core of a bedding or seating product. Such comfort layers commonly have at least one layer of fabric above and at least one layer of fabric below individually pocketed mini coil springs.

[0006] One drawback to such pocketed spring comfort layers is that a mattress manufacturer may desire to place one or more foam or fiber layers above such a pocketed spring comfort layer so that a user does not detect or feel the pocketed spring comfort layer. In the case of a double-sided bedding or seating product, a mattress manufacturer may place one or more foam or fiber layers above one pocketed spring

comfort layer and below another pocketed spring comfort layer on the opposite surface of the central core of the product.

**[0007]** It is therefore an objective of this invention to provide a pocketed spring comfort layer adapted to overlay a central core of a seating or bedding product which may eliminate or reduce the need for a mattress manufacturer to place one or more foam or fiber layers above the pocketed spring comfort layer and yet obtain a posturized effect.

**[0008]** It is another objective of this invention to provide a pocketed spring comfort layer adapted to overlay a central core of a seating or bedding product which may reduce the number or thickness of foam or fiber layers a mattress manufacturer may elect to place above such a pocketed spring comfort layer, thereby reducing the cost of the finished mattress by the cost of such layers and the associated cost of applying them while still obtaining different firmness in different regions.

**[0009]** It is another objective of this invention to provide a pocketed spring comfort layer for a seating or bedding product which has different regions or sections of different firmness.

### **Summary of the Invention**

**[0010]** The invention, which accomplishes these objectives, comprises a comfort layer configured to overlay a central core of a seating or bedding product. The comfort layer comprises an assembly or matrix of individually pocketed mini coil springs, each mini coil spring being contained within a fabric pocket. The fabric pocketing material within which the mini coil springs are contained may be any known fabric, including a non-woven polypropylene fabric commonly used in the bedding industry.

**[0011]** Any of the embodiments of comfort layer shown or described herein may be incorporated into a bedding product, such as a mattress, foundation or pillow. Further, any of the embodiments of comfort layer shown or described herein may be incorporated into a seating product, such as a vehicle seat and/or office or residential furniture, such as a recliner. Alternatively, any of the embodiments of comfort layer shown or described herein may be sold independently as a retail or wholesale item. In such an application, the comfort layer may be added to and/or removed from a bedding or seating product by a customer. Most embodiments of comfort layer are configured to overlay a core of a bedding or seating product such as a pocketed spring core, for example.

**[0012]** According to one aspect of the invention, the comfort layer, whether incorporated inside a bedding or seating product or manufactured and sold as a

separate product, comprises a matrix of interconnected pocketed mini coil springs. Each mini coil spring is contained within a fabric pocket, the fabric pocket having a weld seam at least partially around the pocket joining first and second pieces of fabric to create a pocketed mini coil spring. Each weld seam may be a solid seam or comprise multiple weld segments.

**[0013]** In one embodiment, the comfort layer has at least one tall section and at least one short section. The mini coil springs within the pockets of each tall section may or may not be identical. The mini coil springs within the pockets of each short section may or may not be identical and different than those of the tall section(s). The pocketed mini coil springs of each tall section have a smaller diameter than the pocketed mini coil springs of each short section. The mini coil springs within the pockets of each tall section have an identical first pocketed height, and the pocketed mini coil springs of each short section have an identical second pocketed height less than the first pocketed height of the pocketed mini coil springs of each tall section within standard manufacturing tolerances. Therefore, the sections of the comfort layer having pocketed mini coil springs of greater pocketed height have mini coil springs of a smaller diameter than the diameter of the mini coil springs within the shorter pocketed mini coil springs. The two features, in combination, may result in the taller sections being firmer than the shorter sections of the comfort layer.

**[0014]** In some embodiments, the weld seams are circular, and the weld segments are curved. In other embodiments, the weld seams are rectangular and the weld segments straight. In some embodiments, the weld seams comprise weld segments with gaps therebetween, the weld segments being the same size. However, the weld segments may be different sizes, regardless of the shape of the weld seams.

**[0015]** The comfort layer, whether incorporated inside a bedding or seating product or manufactured and sold as a separate product, comprises a matrix of mini coil springs, a first piece of fabric on one side of the matrix of mini coil springs and a second piece of fabric on another side of the matrix of mini coil springs. The first and second pieces of fabric are joined with weld seams at least partially around each of the mini coil springs, thereby forming individual pockets which contain the mini coil springs. The weld seams may comprise weld segments with gaps therebetween. The weld segments join the first and second pieces of fabric. The comfort layer has different sections of different firmness due, at least in part, to the mini coil springs within at least one of the sections having a larger diameter than the mini coil springs within at least one other section of the comfort layer.

[0016] The comfort layer, whether incorporated inside a bedding or seating product or manufactured and sold as a separate product, comprises mini coil springs, a first piece of fabric on one side of the mini coil springs and a second piece of fabric on another side of the mini coil springs. The first and second pieces of fabric are joined with weld seams at least partially around each of the mini coil springs, thereby creating individual pockets which contain the mini coil springs. The weld seams may comprise weld segments with gaps between the weld segments. The weld segments may be the same size or different sizes. Therefore, the gaps may be the same size or different sizes. The comfort layer has different sections of different firmness due, at least in part, to the different sections having pocketed mini coil springs of different heights. These different pocketed heights may be due, at least in part, to mini coil springs within the pockets having different diameters.

[0017] By changing the gauge of wire, out-of-pocket diameter or out-of-pocket height or any combination thereof of the mini coil springs of different sections of the comfort layer, a posturized comfort layer may be constructed.

[0018] Alternatively, by changing the size of the weld seams containing the mini coil springs within different sections of the comfort layer, a posturized comfort layer may be constructed using the same mini coil springs.

[0019] These and other objects and advantages of this invention will be more readily apparent from the following drawings, in which:

#### **Brief Description of the Drawings**

[0020] Fig. 1 is a perspective view, partially broken away, of a bedding product incorporating one of the comfort layers of this invention;

[0021] Fig. 1A is a perspective view, partially broken away, of another bedding product incorporating the comfort layer of Fig. 1;

[0022] Fig. 2 is a perspective view of the comfort layer used in the bedding product of Fig. 1;

[0023] Fig. 3 is an enlarged top view of the area 3 of Fig. 2;

[0024] Fig. 3A is an enlarged top view like Fig. 3 with different weld seams;

[0025] Fig. 4 is a cross-sectional view taken along the line 4-4 of Fig. 3;

[0026] Fig. 4A is a cross-sectional view taken along the line 4A-4A of Fig. 3A;

[0027] Fig. 5A is a side elevational view of one of the mini coil springs used in the end sections of the comfort layer of Fig. 2;

[0028] Fig. 5B is a top view of the mini coil spring of Fig. 5A;

[0029] Fig. 5C is a cross-sectional view taken along the line 5C-5C of Fig. 3;

- [0030] Fig. 6A is a side elevational view of one of the mini coil springs used in the middle section of the comfort layer of Fig. 2;
- [0031] Fig. 6B is a top view of the mini coil spring of Fig. 6A;
- [0032] Fig. 6C is a cross-sectional view taken along the line 6C-6C of Fig. 3;
- [0033] Fig. 7A is a side elevational view of a mini coil spring which may be used in any tall pocket of any comfort layer shown or described herein;
- [0034] Fig. 7B is a top view of the mini coil spring of Fig. 7A;
- [0035] Fig. 7C is a cross-sectional view of the mini coil spring of Figs. 7A and 7B shown partially compressed in a tall pocket;
- [0036] Fig. 8A is a side elevational view of a mini coil spring which may be used in any short pocket of any comfort layer shown or described herein;
- [0037] Fig. 8B is a top view of the mini coil spring of Fig. 8A;
- [0038] Fig. 8C is a cross-sectional view of the mini coil spring of Figs. 8A and 8B shown partially compressed in a short pocket;
- [0039] Fig. 9A is a side elevational view of a mini coil spring which may be used in any tall pocket of any comfort layer shown or described herein;
- [0040] Fig. 9B is a top view of the mini coil spring of Fig. 9A;
- [0041] Fig. 9C is a cross-sectional view of the mini coil spring of Figs. 9A and 9B shown partially compressed in a tall pocket;
- [0042] Fig. 10A is a side elevational view of a mini coil spring which may be used in any short pocket of any comfort layer shown or described herein;
- [0043] Fig. 10B is a top view of the mini coil spring of Fig. 10A;
- [0044] Fig. 10C is a cross-sectional view of the mini coil spring of Figs. 10A and 10B shown partially compressed in a short pocket;
- [0045] Fig. 11A is a perspective view of another comfort layer, the middle section being a tall section and the end sections being short sections;
- [0046] Fig. 11B is a perspective view of another comfort layer having one tall section and one short section;
- [0047] Fig. 12 is a perspective view of another comfort layer made in accordance with the invention;
- [0048] Fig. 13 is a top view of the area 13 of Fig. 12;
- [0049] Fig. 13A is a cross-sectional view taken along the line 13A-13A of Fig. 13;
- [0050] Fig. 14 is a perspective view of another comfort layer made in accordance with the invention which may be used in any bedding or seating product;
- [0051] Fig. 15 is a top view of the area 15 of Fig. 14;

- [0052] Fig. 16A is a side elevational view of a mini coil spring which may be used in any pocket of any comfort layer shown or described herein;
- [0053] Fig. 16B is a top view of the mini coil spring of Fig. 16A;
- [0054] Fig. 16C is a cross-sectional view taken along the line 16C-16C of Fig. 15;
- [0055] Fig. 17A is a side elevational view of the mini coil spring of Fig. 16A;
- [0056] Fig. 17B is a top view of the mini coil spring of Fig. 17A;
- [0057] Fig. 17C is a cross-sectional view taken along the line 17C-17C of Fig. 15;
- [0058] Fig. 18A is a perspective view of another comfort layer made in accordance with the invention which may be used in any bedding or seating product;
- [0059] Fig. 18B is a perspective view of another comfort layer made in accordance with the invention which may be used in any bedding or seating product;
- [0060] Fig. 18C is a perspective view of another comfort layer made in accordance with the invention which may be used in any bedding or seating product;
- [0061] Fig. 18D is a perspective view of another comfort layer made in accordance with the invention which may be used in any bedding or seating product;
- [0062] Fig. 19 is a perspective view of another comfort layer made in accordance with the invention which may be used in any bedding or seating product;
- [0063] Fig. 19A is an enlarged top view of the area 19A of Fig. 19;
- [0064] Fig. 19B is a cross-sectional view taken along the line 19B-19B of Fig. 19A;
- [0065] Fig. 20 is a perspective view of another comfort layer made in accordance with the invention which may be used in any bedding or seating product;
- [0066] Fig. 20A is an enlarged top view of the area 20A of Fig. 20;
- [0067] Fig. 20B is a cross-sectional view taken along the line 20B-20B of Fig. 20A;
- [0068] Fig. 21 is a perspective view of another comfort layer made in accordance with the invention which may be used in any bedding or seating product;
- [0069] Fig. 21A is an enlarged top view of the area 21A of Fig. 21;
- [0070] Fig. 21B is a cross-sectional view taken along the line 21B-21B of Fig. 21A;
- [0071] Fig. 22 is a perspective view of another comfort layer made in accordance with the invention which may be used in any bedding or seating product;
- [0072] Fig. 22A is an enlarged top view of the area 22A of Fig. 22; and
- [0073] Fig. 22B is a cross-sectional view taken along the line 22B-22B of Fig. 22A.

[0074] Fig. 23 is a perspective view of another comfort layer made in accordance with the invention which may be used in any bedding or seating product;

[0075] Fig. 23A is an enlarged top view of the area 23A of Fig. 23; and

[0076] Fig. 23B is a cross-sectional view taken along the line 23B-23B of Fig. 23A.

### **Detailed Description of the Drawings**

[0077] With reference to Fig. 1, there is illustrated a single-sided mattress 10 incorporating one embodiment of comfort layer in accordance with this invention. This mattress 10 comprises a spring core 12 over the top of which there is a conventional cushioning pad 14 which may be partially or entirely made of foam or fiber or gel, etc. The cushioning pad 14 may be covered by a posturized comfort layer 16 constructed in accordance with one embodiment of the invention. A second conventional cushioning pad 14 may be located above the posturized comfort layer 16. In some applications, one or both cushioning pads 14 may be omitted. This complete assembly may be mounted upon a base 18 and is completely enclosed within an upholstered cover 20.

[0078] As shown in Fig. 1, mattress 10 has a longitudinal dimension or length L, a transverse dimension or width W and a height H. Although the length L is shown as being greater than the width W, they may be identical. The length, width and height may be any desired distance and are not intended to be limited by the drawings.

[0079] While several embodiments of comfort layer are illustrated and described as being embodied in a single-sided mattress, any of the comfort layers shown or described herein may be used in a single-sided mattress, double-sided mattress or seating cushion. In the event any such comfort layer is utilized in connection with a double-sided product, then the bottom side of the product's core may have a comfort layer applied over the bottom side of the core, and either comfort layer may be covered by one or more cushioning pads made of any conventional material. Either the cushioning pad or pads, on top and/or bottom of the core, may be omitted. The novel features of the invention reside in the comfort layer.

[0080] Fig. 1A illustrates another mattress 10a having the same components as mattress 10 except a pocketed spring core 12a rather than a conventional spring core 12 shown in Fig. 1. Although spring core 12 is illustrated being made of unpocketed coil springs held together with helical lacing wires, the core of any of the products, such as mattresses shown or described herein, may be made wholly or partially of pocketed coil springs (see Fig. 1A), one or more foam pieces (not shown) or any combination thereof. Any of the comfort layers described or shown herein may be used in any single

or double-sided bedding or seating product having any conventional core. This document is not intended to limit in any way the core. The core may be any conventional core including, but not limited to, pocketed or conventional spring cores.

**[0081]** Figs. 3 and 4 illustrate the components of one embodiment of posturized comfort layer 16 incorporated into the mattress 10 shown in Fig. 1. As best shown in Fig. 4, the posturized comfort layer 16 comprises a first or upper piece of fabric 22 and a second or lower piece of fabric 24 with a plurality of mini coil springs 26, 28 therebetween. The fabric pieces 22, 24 are made of non-woven polypropylene in one embodiment, but one or both may be made of any known material. The fabric pieces 22, 24 are preferably made of the same material, but may be made of different materials. The fabric pieces 22, 24 are joined together with rectangular weld seams 30, each rectangular seam 30 surrounding one of the mini coil springs 26 or 28.

**[0082]** Each rectangular seam 30 comprises multiple straight or linear weld segments 32 with gaps 34 therebetween. The first and second pieces of fabric 22, 24 are joined together along each straight or linear weld segment 32 of each rectangular seam 30. The first and second pieces of fabric 22, 24 are not joined together along each gap 34 between adjacent weld segments 32 of each rectangular seam 30. The straight or linear weld segments 32 are strategically placed around a mini coil spring 26, 28 and create the rectangular seam 30. The two pieces of fabric 22, 24, in combination with one of the rectangular weld seams 30, define a pocket 36, 38 inside of which is at least one mini coil spring 26, 28, respectively. For purposes of this document, the two pieces of fabric 22, 24, in combination with one of the rectangular weld seams 30 and at least one mini coil spring 26, 28 define a pocketed mini coil spring 44, 46, respectively.

**[0083]** Figs. 3A and 4A illustrate the components of posturized comfort layer 16 shown in Figs. 3 and 4, but with solid rectangular weld seams 31 in place of segmented weld seams 30. In any of the embodiments described herein or shown, solid or partially solid weld seams may replace segmented weld seams of any shape, including circular weld seams. Figs. 3A and 4A are merely one example.

**[0084]** As best shown in Figs. 2 and 3, the pocketed mini coil springs 44, 46 are arranged in a matrix of aligned transversely extending rows 48 extending from side-to-side and longitudinally extending columns 50 extending from head-to-foot. See Figs. 3 and 4.

**[0085]** During the welding process, the mini coil springs 26, 28 may be at least partially compressed before pocket 36, 38 is closed and thereafter. If desired, resilient members other than mini coil springs, such as foam members, may be used in this

embodiment and any embodiment disclosed or shown herein. Alternatively, resilient members made of resilient material, other than foam which returns to its original configuration after a load is removed from the material, may be used inside the pockets in any embodiment disclosed or shown herein.

**[0086]** The size of the straight or linear weld segments 32 of rectangular seams 30 are not intended to be limited by the illustrations; they may be any desired size. Similarly, the size of the illustrated rectangular seams 30, is not intended to be limiting. The placement of the rectangular seams 30 shown in the drawings is not intended to be limiting either. Any desired arrangement of rectangular seams may be incorporated into any embodiment shown or described herein.

**[0087]** The weld segments 32 may assume shapes other than the straight or linear weld segments illustrated. For example, the weld seams 32 may be other shapes, such as triangles or circles or ovals of the desired size and pattern. This holds true for any of the weld seams described herein regardless of whether circular or rectangular and regardless of the comfort layer described herein or shown in this document.

**[0088]** Fig. 2 illustrates the posturized comfort layer 16 having a center section 40 and two end sections 42 on opposite sides of the center section 40. Each of the three sections 40, 42 is illustrated being generally rectangular shaped and approximately the same size. However, any one of the sections may be a different size than any other section. For example, the end sections 42 may be a different size than the middle or center section 40. The drawings are not intended to be limiting.

**[0089]** Each of the end sections 42 has identical pocketed mini coil springs 44. For purposes of this document, each of the end sections 42 will be referred to as a “tall” section, and each of the pocketed mini coil springs 44 will be referred to as a “tall” pocketed mini coil spring. Each tall pocketed mini coil spring 44, shown in detail in Figs. 4 and 5C, comprises a partially compressed mini coil spring 26 and first and second pieces 22, 24 of fabric joined together with a rectangular weld seam 30. As shown in Fig. 5A, each mini coil spring 26 has an out-of-pocket height H1 in its relaxed or non-compressed condition. As shown in Fig. 5B, each mini coil spring 26 has a diameter of D1 in its relaxed or non-compressed condition. As shown in Figs. 4 and 5C, each mini coil spring 26, when pocketed, creates a tall pocketed mini coil spring 44 having a pocketed height H3, less than the out-of-pocket height H1 of mini coil spring 26.

**[0090]** The center section 40 has identical pocketed mini coil springs 46. For purposes of this document, the center section 40 will be referred to as a “short” section,

and each of the pocketed mini coil springs 46 will be referred to as a “short” pocketed mini coil spring. Each short pocketed mini coil spring 46, shown in detail in Figs. 4 and 6C, comprises a mini coil spring 28 and first and second pieces 22, 24 of fabric joined together with a rectangular weld seam 30. As shown in Fig. 6A, each mini coil spring 28 has an out-of-pocket height H2 in its relaxed or non-compressed condition, greater than the out-of-pocket height H1 of mini coil spring 26 shown in Fig. 5A. As shown in Fig. 6B, each mini coil spring 28 has diameter D2 in its relaxed or non-compressed condition greater than the diameter D1 of mini coil spring 26 shown in Fig. 5B. As shown in Figs. 4 and 6C, each mini coil spring 28, when pocketed, creates a short pocketed mini coil spring 46 having a height H4, less than the height H3 of tall pocketed mini coil spring 44 shown in Fig. 5C and less than the out-of-pocket height H2 of mini coil spring 28.

**[0091]** Each of the pocketed mini coil springs of the center section 40 is illustrated being a short pocketed mini coil spring 46, as described herein and shown in Figs. 4 and 6C. Each of the pocketed mini coil springs of each of the end sections 42 is illustrated being a tall pocketed mini coil spring 44, as described herein and shown in Figs. 4 and 5C. As shown in Fig. 2, each row 48 of tall pocketed mini coil springs 44 in the end sections 42 is identical. Similarly, each row 48 of short pocketed mini coil springs 46 in the center section 40 is identical. The center section 40 is shorter than the end sections 42 because the rows 48 of short pocketed mini coil springs 46 are shorter than the rows 48 of tall pocketed mini coil springs 44 in the end sections 42. As best seen in Fig. 2, each longitudinally extending column 50 of pocketed mini coil springs 44, 46 is identical along the length of the posturized comfort layer 16.

**[0092]** Any dimensions shown or described herein may be any desired dimensions and are not intended to be limited by this document. For example, dimensions H1-H5, D1 and D2 may be any desired dimensions. However, in one preferred embodiment, the out-of-pocket height H1 of mini coil spring 26 shown in Fig. 5A and the out-of-pocket height H1 of mini coil spring 54 shown in Fig. 8A may be approximately 1.25 inches. In the same preferred embodiment, the out-of-pocket height H2 of mini coil spring 28 shown in Fig. 5B, the out-of-pocket height H2 of mini coil spring 52 shown in Fig. 7A and the out-of-pocket height H5 of mini coil springs 60, 64 shown in Figs. 9A and 10A, respectively, may be approximately 2.0 inches. In the same preferred embodiment, the diameter D1 of the uncompressed mini coil spring 26 shown in Fig. 5B and the mini coil spring 52 shown in Fig. 7B may be approximately 1.25 inches. In the same preferred embodiment, the diameter D2 of the uncompressed mini coil spring 28 shown in Fig. 6B and the mini coil spring 54 shown in Fig. 8B may be

approximately 1.75 inches. In most embodiments, the height of the pocketed mini coil springs is less than three inches.

**[0093]** According to one aspect of the invention, the mini coil springs within a comfort layer, such as mini coil springs 26, 28, may be made of the same wire. In one embodiment, these mini coil springs 26, 28 may be both made of seventeen-gauge wire. However, any of the mini coil springs described herein or shown may be made of any gauge wire.

**[0094]** Figs. 7A and 7B show an alternative mini coil spring 52 in an out-of-pocket condition which may be at least partially compressed and pocketed to create a tall pocketed mini coil spring 56 shown in Fig. 7C. Tall pocketed mini coil spring 56 may be incorporated into any of the comfort layers shown or described herein, including posturized comfort layer 16. In place of tall pocketed mini coil springs 44, tall pocketed mini coil springs 56, shown in Fig. 7C, may be used in any of the comfort layers shown or described herein, including in each of the end sections 42 of posturized comfort layer 16. Each tall pocketed mini coil spring 56, shown in detail in Fig. 7C, comprises a mini coil spring 52, shown in a relaxed or non-compressed condition in Fig. 7A, and first and second pieces 22, 24 of fabric joined together with a rectangular weld seam 30. As shown in Fig. 7A, each mini coil spring 52 has an out-of-pocket height  $H_2$  in its relaxed or non-compressed condition. As shown in Fig. 7B, each mini coil spring 52 has diameter of  $D_1$  in its relaxed or non-compressed condition. As shown in Fig. 7C, each mini coil spring 52, when pocketed, creates a tall pocketed mini coil spring 56 having a pocketed height  $H_3$ .

**[0095]** Figs. 8A and 8B show an alternative mini coil spring 54 in an out-of-pocket condition, which may be at least partially compressed and pocketed to create a short pocketed mini coil spring 58 shown in Fig. 8C. Short pocketed mini coil springs 58 may be incorporated into any of the comfort layers shown or described herein, including posturized comfort layer 16. In place of short pocketed mini coil springs 46 shown in Fig. 6C, short pocketed mini coil springs 58 shown in Fig. 8C may be used in any of the short sections of any of the posturized comfort layers shown or described herein, including the center section 40 of posturized comfort layer 16. Each short pocketed mini coil spring 58, shown in detail in Fig. 8C, comprises a mini coil spring 54 partially compressed between first and second pieces 22, 24 of fabric joined together with a rectangular weld seam 30. As shown in Fig. 8A, each mini coil spring 54 has an out-of-pocket height  $H_1$  in its relaxed or non-compressed condition, less than the out-of-pocket height  $H_2$  of mini coil spring 52 shown in Fig. 7A. As shown in Fig. 8B, each mini coil

spring 54 has diameter  $D_2$  in its relaxed or non-compressed condition greater than the diameter  $D_1$  of the mini coil spring 52 shown in Fig. 7A. As shown in Fig. 8C, each mini coil spring 54, when at least partially compressed and pocketed, creates a short pocketed mini coil spring 58 having a height  $H_4$ , less than the height  $H_3$  of tall pocketed mini coil spring 56 shown in Fig. 7C.

**[0096]** According to one aspect of the invention, the mini coil springs within a comfort layer, such as mini coil springs 52, 54, may be made of the same wire. In one embodiment, mini coil springs 52, 54 may be both made of seventeen-gauge wire. However, mini coil springs 52, 54 may be made of any gauge wire, including different gauge wires.

**[0097]** In any of the comfort layers shown or described herein, including posturized comfort layer 16, tall pocketed mini coil springs 44, like the one shown in Fig. 5C and short pocketed mini coil springs 46 like the one shown in Fig. 6C, may be used together in the same comfort layer. Similarly, the tall pocketed mini coil springs 56, like the one shown in Fig. 7C and short pocketed mini coil springs 58 like the one shown in Fig. 8C, may be used together in the same comfort layer.

**[0098]** Figs. 9C and 10C illustrate another set of tall and short pocketed mini coil springs, which may be used together in any of the comfort layers shown or described herein. Figs. 9A and 9B show an alternative mini coil spring 60 in an out-of-pocket condition, which may be partially compressed and pocketed to create a tall pocketed mini coil spring 62, shown in Fig. 9C. Tall pocketed mini coil springs 62 may be incorporated into any of the comfort layers shown or described herein, including in any of the tall sections of any of the posturized comfort layers shown or described herein, including the end sections 42 of posturized comfort layer 16. Each tall pocketed mini coil spring 62, shown in detail in Fig. 9C, comprises a mini coil spring 60 and first and second pieces 22, 24 of fabric joined together with a rectangular weld seam 30. As shown in Fig. 9A, each mini coil spring 60 has an out-of-pocket height  $H_5$  in its relaxed or non-compressed condition. As shown in Fig. 9B, each mini coil spring 60 has diameter of  $D_1$  in its relaxed or non-compressed condition. As shown in Fig. 9C, each mini coil spring 60, when pocketed, creates a tall pocketed mini coil spring 62 having a pocketed height  $H_3$ .

**[0099]** Figs. 10A and 10B show a mini coil spring 64 in an out-of-pocket condition, which may be partially compressed and pocketed to create a short pocketed mini coil spring 66, shown in Fig. 10C. Short pocketed mini coil springs 66 may be incorporated into any of the comfort layers shown or described herein, including in any

of the short sections of any of the posturized comfort layers shown or described herein, such as the center section 40 of posturized comfort layer 16. Each short pocketed mini coil spring 66, shown in detail in Fig. 10C, comprises a mini coil spring 64 partially compressed between first and second pieces 22, 24 of fabric joined together with a rectangular weld seam 30. As shown in Fig. 10A, each mini coil spring 64 has an out-of-pocket height H5 in its relaxed or non-compressed condition, the same out-of-pocket height as the out-of-pocket height H5 of mini coil spring 60 shown in Fig. 9A. As shown in Fig. 10B, each mini coil spring 64 has diameter D2 in its relaxed or non-compressed condition, greater than the diameter D1 of the mini coil spring 60 shown in Fig. 9B. As shown in Fig. 10C, each mini coil spring 64, when partially compressed and pocketed, creates a short pocketed mini coil spring 66 having a height H4, less than the height H3 of tall pocketed mini coil spring 62 shown in Fig. 9C.

**[00100]** According to one aspect of the invention, within a comfort layer, such as mini coil springs 60, 62, may be made of the same wire. In one embodiment, mini coil springs 60, 62 may be both made of seventeen-gauge wire. However, mini coil springs 60, 62 may be made of any gauge wire, including different gauge wires.

**[00101]** In posturized comfort layer 16, the end sections 42 are firmer than the center section 40 because the pocketed mini coil springs of the end sections 42 are tall pocketed mini coil springs 44 and the pocketed mini coil springs of the center section 40 are short pocketed mini coil springs 46. Any of the other combinations of short and tall pocketed mini coil springs, such as those shown in Figs. 7C and 8C or Figs. 9C and 10C, may be incorporated into posturized comfort layer 16, as well as any other comfort layer shown or described herein.

**[00102]** Fig. 11A illustrates another posturized comfort layer 16a in which the orientation of the pocketed mini coil springs is different than the orientation of the pocketed mini coil springs in posturized comfort layer 16. Fig. 11A illustrates the posturized comfort layer 16a having a center section 40a and two end sections 42a on opposite sides of the center section 40a. Each of the three sections 40a, 42a is generally rectangular shaped and approximately the same size. However, any one of the sections may be a different size than any other section. For example, the end sections 42a may be a different size than the middle or center section 40a. The drawings are not intended to be limiting.

**[00103]** The center section 40a is firmer than the end sections 42a because the pocketed mini coil springs of the center section 40a are tall pocketed mini coil springs 44 and the pocketed mini coil springs of the end sections 42 are short pocketed mini

coil springs 46. Any of the other combinations of short and tall pocketed mini coil springs, such as those shown in Figs. 7C and 8C or Figs. 9C and 10C, may be incorporated into posturized comfort layer 16a, as well as any other posturized comfort layer shown or described herein.

**[00104]** As best shown in Fig. 11A, the pocketed mini coil springs 44, 46 are arranged in a matrix of aligned transversely extending rows 48a extending from side-to-side and longitudinally extending columns 50a extending from head-to-foot. Each of the pocketed mini coil springs of the center section 40a is illustrated being a tall mini coil spring 46, as described herein and shown in Figs. 4 and 5C. Each of the pocketed mini coil springs of the end sections 42a is illustrated being a short pocketed mini coil spring 46, as described below and shown in Figs. 4 and 6C. As shown in Fig. 11A, each row 48a of short pocketed mini coil springs 46 in the end sections 42a is identical. Similarly, each row 48a of tall pocketed mini coil springs 44 in the center section 40a is identical. The center section 40a is taller than the end sections 42a because the rows 48a of pocketed mini coil springs 44 in the center section 40a are taller than the rows 48a of pocketed mini coil springs 46 in the end sections 42a. Each longitudinally extending column 50a of pocketed mini coil springs 44, 46 is identical along the length of the posturized comfort layer 16a.

**[00105]** Fig. 11B illustrates another posturized comfort layer 16b. Fig. 11B illustrates the posturized comfort layer 16b having a firm section 70 and a soft section 72 side-by-side. Each of the firm and soft sections 70, 72 is generally rectangular and approximately the same size. However, one of the sections 70, 72 may be a different size than the other section. The drawings are not intended to be limiting.

**[00106]** In posturized comfort layer 16b, the firm section 70 is firmer than the soft section 72 because the pocketed mini coil springs of the firm section 70 are tall pocketed mini coil springs 44 and the pocketed mini coil springs of the soft section 72 are short pocketed mini coil springs 46. Any of the other combinations of short and tall pocketed mini coil springs, such as those shown in Figs. 7C and 8C or Figs. 9C and 10C, may be incorporated into posturized comfort layer 16b, as well as any other comfort layer shown or described herein.

**[00107]** As best shown in Fig. 11B, the pocketed mini coil springs 44, 46 are arranged in a matrix of aligned transversely extending rows 48b extending from side-to-side and longitudinally extending columns 50b extending from head-to-foot. Each of the pocketed mini coil springs of the firm section 70 is illustrated being a tall mini coil spring 44, as described herein and shown in Figs. 4 and 5C. Each of the pocketed mini coil

springs of the soft section 72 is illustrated being a short pocketed mini coil spring 46, as described below and shown in Figs. 4 and 6C. As shown in Fig. 11B, each column 50b of short pocketed mini coil springs 46 in the soft section 72 is identical. Similarly, each column 50b of tall pocketed mini coil springs 44 in the firm section 70 is identical, taller than the columns 50 of pocketed mini coil springs 44 in the soft section 72. Each transversely extending row 48b of pocketed mini coil springs 44, 46 is identical in the posturized comfort layer 16b.

**[00108]** Figs. 12, 13 and 13A illustrate another posturized comfort layer 16c having pocketed mini coil springs 44c, 46c having circular welds, rather than rectangular welds, joining the first and second pieces of fabric 22, 24. Fig. 12 illustrates the posturized comfort layer 16c having a center section 40c and two end sections 42c on opposite sides of the center section 40c. Each of the three sections 40c, 42c is generally rectangular and approximately the same size. However, any one of the sections may be a different size than any other section. For example, the end sections 42c may be a different size than the middle or center section 40c. The drawings are not intended to be limiting.

**[00109]** In posturized comfort layer 16c, the end sections 42c are firmer than the center section 40c because the pocketed mini coil springs of the end sections 42c are tall pocketed mini coil springs 44c and the pocketed mini coil springs of the center section 40c are short pocketed mini coil springs 46c. Any of the other combinations of short and tall pocketed mini coil springs, such as those shown in Figs. 7C and 8C or Figs. 9C and 10C, may be incorporated into posturized comfort layer 16c, as well as any other comfort layer shown or described herein.

**[00110]** As best shown in Fig. 12, the pocketed mini coil springs 44c, 46c are arranged in a matrix of aligned transversely extending rows 48c extending from side-to-side and aligned longitudinally extending columns 50c extending from head-to-foot. Each of the pocketed mini coil springs of the center section 40c is illustrated being a short mini coil spring 46c, as described herein and shown in Figs. 12, 13 and 13A. Each of the pocketed mini coil springs of the end sections 42c is illustrated being a tall pocketed mini coil spring 44c, as described below and shown in Figs. 12, 13 and 13A. As shown in Fig. 12, each row 48c of tall pocketed mini coil springs 44c in each of the end sections 42c is identical. Similarly, each row 48c of short pocketed mini coil springs 46c in the center section 40c is identical, but is shorter than the rows 48 of pocketed mini coil springs 44c in the end sections 42c. Each longitudinally extending column 50c

of pocketed mini coil springs is identical, having both pocketed mini coil springs 44c, 46c.

**[00111]** Fig. 13A illustrates the components of one embodiment of comfort layer 16c shown in Figs. 12 and 13. The comfort layer 16c comprises a first or upper piece of fabric 22 and a second or lower piece of fabric 24 with a plurality of mini coil springs 26, 28 therebetween. The fabric pieces 22, 24 are joined together with circular weld seams 74, each circular seam 74 surrounding a mini coil spring 26, 28. Each circular seam 74 comprises multiple arced or curved weld segments 76 with gaps 78 therebetween. The first and second pieces of fabric 22, 24 are joined together along each arced or curved weld segment 76 of each circular seam 74. The first and second pieces of fabric 22, 24 are not joined together along each gap 78 between adjacent weld segments 76 of each circular seam 74. The curved weld segments 76 are strategically placed around a mini coil spring 26, 28 and create the circular seam 74. The two pieces of fabric 22, 24, in combination with one of the circular weld seams 74, define a cylindrical-shaped pocket 36c, 38c inside of which is at least one mini coil spring 26, 28. See Figs. 13 and 13A.

**[00112]** During the welding process, the mini coil springs 26, 28 may be at least partially compressed before pocket 36c, 38c is closed and thereafter. If desired, resilient members other than mini coil springs, such as foam members, may be used and any embodiment disclosed or shown herein. Alternatively, resilient members made of resilient material, other than foam which returns to its original configuration after a load is removed from the material, may be used inside the pockets in any embodiment disclosed or shown herein.

**[00113]** The embodiment of posturized comfort layer 16c shown in Figs. 12, 13 and 13A illustrates all the circular weld seams 74 being the same diameter D3. The difference in the height of the pocketed mini coil springs 44c, 46c is due to the different mini coil springs being inside the pockets.

**[00114]** Although the drawings show a certain size of the curved weld segments 76 of circular weld seams 74, the size of the curved weld segments 76 of circular weld seams 74 are not intended to be limited by the illustrations; they may be any desired size. Similarly, although the drawings show the circular weld seams 74 having a certain diameter D3, the diameter of the illustrated circular weld seams 74 is not intended to be limiting.

**[00115]** Figs. 14, 15, 16A-16C and 17A-17C illustrate another posturized comfort layer 16d having identical mini coil springs 80 throughout, but circular welds of different diameters D3 and D4 joining the first and second pieces of fabric 22, 24. Fig. 14

illustrates the posturized comfort layer 16d having a center section 40d and two end sections 42d on opposite sides of the center section 40d. Each of the three sections 40d, 42d is generally rectangular shaped and approximately the same size. However, any one of the sections may be a different size than any other section. For example, the end sections 42d may be a different size than the middle or center section 40d. The drawings are not intended to be limiting.

**[00116]** In posturized comfort layer 16d, the end sections 42d are firmer than the center section 40d because the pocketed mini coil springs of the end sections 42d are tall pocketed mini coil springs 44d and the pocketed mini coil springs of the center section 40d are short pocketed mini coil springs 46d.

**[00117]** As best shown in Fig. 14, the tall pocketed mini coil springs 44d of each end section 42d are arranged in a matrix of aligned transversely extending rows 48d extending from side-to-side and aligned longitudinally extending columns 50d extending from head-to-foot. Likewise, the short pocketed mini coil springs 46d of the center section 40d are arranged in a matrix of aligned transversely extending rows 49 extending from side-to-side. As best shown in Fig. 14, each aligned longitudinally extending column 50d extending from head-to-foot is identical and has a group or set of short pocketed mini coil springs 46d between groups or sets of tall pocketed mini coil springs 44d.

**[00118]** As shown in Fig. 14, each row 48d of tall pocketed mini coil springs 44d in each of the end sections 42d is identical. Similarly, each row 49 of short pocketed mini coil springs 46d in the center section 40d is identical, having a different height (is shorter) than the rows 48d of pocketed mini coil springs 44d in the end sections 42d.

**[00119]** Each of the pocketed mini coil springs of the center section 40d is illustrated being a short pocketed mini coil spring 46d, as described herein and shown in Figs. 16A, 16B and 16C. Each of the pocketed mini coil springs 44d of the end sections 42d is illustrated being a tall pocketed mini coil spring 44d, as described below and shown in Figs. 17A, 17B and 17C.

**[00120]** Fig. 16C illustrates the components of one of the short pocketed mini coil springs 46d. The short pocketed mini coil spring 46d comprises a first or upper piece of fabric 22 and a second or lower piece of fabric 24 with a partially compressed mini coil spring 80 therebetween. The fabric pieces 22, 24 are joined together with circular weld seams 82. As best shown in Fig. 15, each circular seam 82 has a diameter D3 and surrounds a partially compressed mini coil spring 80. As shown in Fig. 16A, each mini coil spring 80 has an out-of-pocket height H6 in its relaxed or non-compressed

condition. As shown in Fig. 16B, each mini coil spring 80 has diameter of D5 in its relaxed or non-compressed condition.

**[00121]** As best seen in Fig. 15, each small circular seam 82 comprises multiple arced or curved weld segments 84 with gaps 86 therebetween. The first and second pieces of fabric 22, 24 are joined together along each arced or curved weld segment 84 of each small circular seam 82. The first and second pieces of fabric 22, 24 are not joined together along each gap 86 between adjacent weld segments 84 of each small circular seam 82. The curved weld segments 84 are strategically placed around a mini coil spring 80 and create the small circular seam 82. The two pieces of fabric 22, 24, in combination with one of the small circular weld seams 82, define a cylindrical-shaped pocket 38d inside of which is at least one partially compressed mini coil spring 80. See Figs. 16C.

**[00122]** Fig. 17C illustrates the components of one of the tall pocketed mini coil springs 44d. The tall pocketed mini coil spring 44d comprises a first or upper piece of fabric 22 and a second or lower piece of fabric 24 with a partially compressed mini coil spring 80 therebetween. The fabric pieces 22, 24 are joined together with large circular weld seams 88. As best shown in Fig. 15, each large circular seam 88 has a diameter D4, greater than the diameter D3 of the small circular weld seams 82 of the short pocketed mini coil springs 46d. Each large circular seam 88 surrounds a partially compressed mini coil spring 80. As shown in Fig. 17A, each mini coil spring 80 has an out-of-pocket height H6 in its relaxed or non-compressed condition. As shown in Fig. 17B, each mini coil spring 80 has diameter of D5 in its relaxed or non-compressed condition.

**[00123]** As best seen in Fig. 15, each circular seam 88 comprises multiple arced or curved weld segments 90 with gaps 92 therebetween. The first and second pieces of fabric 22, 24 are joined together along each arced or curved weld segment 90 of each circular seam 88. The first and second pieces of fabric 22, 24 are not joined together along each gap 92 between adjacent weld segments 90 of each circular seam 88. The curved weld segments 90 are strategically placed around a mini coil spring 80 and create the circular seam 88. The two pieces of fabric 22, 24, in combination with one of the circular weld seams 88, define a cylindrical-shaped pocket 36d inside of which is at least one partially compressed mini coil spring 80. See Figs. 17C.

**[00124]** During the welding process, the mini coil springs 80 may be at least partially compressed before pocket 36d, 38d is closed and thereafter. If desired, resilient members other than mini coil springs, such as foam members, may be used.

Alternatively, resilient members made of resilient material, other than foam which returns to its original configuration after a load is removed from the material, may be used inside the pockets.

**[00125]** The embodiment of posturized comfort layer 16d shown in Figs. 14, 15, 16A-16C and 17A-17C illustrates small and large circular weld seams 82, 88, respectively, of different diameters. The difference in the height of the pocketed mini coil springs 44d, 46d in the different sections is due to the different diameters of the circular weld seams, the mini coil springs inside the pockets being identical.

**[00126]** Although the drawings show a certain size of the curved weld segments 84, 90 of circular weld seams 82, 88, respectively, the size of the curved weld segments 84, 90 of circular weld seams 82, 88, respectively, are not intended to be limited by the illustrations; they may be any desired size. Similarly, although the drawings show the circular weld seams 82, 88 having a certain diameters D3, D4, respectively, the diameter of the illustrated circular weld seams 82, 88 is not intended to be limiting.

**[00127]** Although the posturized comfort layer 16d shows a center section 40d having a softer feel than the feel of the end sections 42d because the circular weld seams 82 of the short pocketed mini coil springs 46d have a smaller diameter than the circular weld seams 88 of the tall pocketed mini coil springs 46d, it is within the scope of the invention that any comfort layer shown or described herein may incorporate different diameter weld seams with the same mini coil springs to create pocketed mini coil springs of different heights and different firmness. For example, a posturized comfort layer like the posturized comfort layer 16a shown in Fig. 11A or a posturized comfort layer like the posturized comfort layer 16b shown in Fig. 11B may be created using circular weld seams of different diameters with the same mini coil springs.

**[00128]** Fig. 18A illustrates another posturized comfort layer 16e having four tall sections 94 and three short sections 96, each of the sections 94, 96 extending the full length of the posturized comfort layer 16e. Adjacent tall sections 94 are separated by a longitudinally extending short section 96 of short pocketed mini coil springs 46. The pocketed mini coil springs of each of the tall sections 94 are tall pocketed mini coil springs 44, thus resulting in firmer sections than the short sections 96 of the posturized comfort layer 16e. Each of the tall sections 94 is generally rectangular shaped, comprises multiple columns and is approximately the same size. However, any one of the sections may be a different size than any other section. For example, any of the tall sections 94 may be a different size than any other tall section.

**[00129]** Although Fig. 18A shows each short section 96 comprising only one longitudinally extending column of short pocketed mini coil springs 46 between adjacent tall sections 94, one or more short sections 96 may comprise two or more longitudinally extending columns of short pocketed mini coil springs 46 between adjacent tall sections 94. Similarly, although Fig. 18A shows each tall section 94 comprising four columns of tall pocketed mini coil springs 44, each tall section may comprise any desired number of columns of tall pocketed mini coil springs. Although Fig. 18A shows four tall sections 94 and three short sections 96, such a posturized comfort layer may have any number of tall sections and short sections. The sections may extend from side-to-side rather than from head-to-foot as shown in Fig. 18A, in which case each section would comprise multiple rows of pocketed mini coil springs of a desired height. The drawings are not intended to be limiting.

**[00130]** As best shown in Fig. 18A, each longitudinally extending column of short pocketed mini coil springs 46 between adjacent tall sections 94 is known in the art as a “spacer” column. One purpose/benefit of the spacer column(s) is the manufacturer of the comfort layer uses the same amount of fabric material along the entire width and length of the comfort layer 16e which results in a rectangular comfort layer, within normal manufacturing tolerances. For manufacturing purposes, a comfort layer which is rectangular, within normal manufacturing tolerances, is more desirable than a product which is not so evenly dimensioned. This benefit of the spacer column(s) or row(s) applies to any of the embodiments shown or described herein, including the comfort layers shown in Figs. 18A-18D, even if the comfort layer only has one spacer row or column of spacer pocketed springs. This benefit applies regardless of the height and direction and length of the spacer column(s) or row(s).

**[00131]** As best shown in Fig. 18A, the pocketed mini coil springs 44, 46 are arranged in a matrix of aligned transversely extending rows 48e extending from side-to-side and longitudinally extending columns 50e extending from head-to-foot. In this embodiment, each of the pocketed mini coil springs along each of the columns is identical. However, the pocketed mini coil springs within the columns of the tall sections are different than the pocketed mini coil springs within the columns of the short sections. Each of the pocketed mini coil springs of each of the tall sections 94 is illustrated being a tall pocketed mini coil spring 44, as described herein and shown in Fig. 5C. Each of the pocketed mini coil springs of each short section 96 is illustrated being a short pocketed mini coil spring 46, as described herein and shown in Fig. 6C. In place of tall pocketed mini coil springs 44, tall pocketed mini coil springs, like tall

pocketed mini coil springs 56 shown in Fig. 7C or tall pocketed mini coil springs 62 shown in Fig. 9C, may be used in any of the tall sections 94 of posturized comfort layer 16e. Similarly, in place of short pocketed mini coil springs 46, short pocketed mini coil springs, like short pocketed mini coil springs 58 shown in Fig. 8C or short pocketed mini coil springs 66 shown in Fig. 10C, may be used in any of the short sections 96 of posturized comfort layer 16e.

**[00132]** Although Fig. 18A illustrates the pocketed mini coil springs having rectangular weld seams, circular weld seams may be incorporated into the pocketed mini coil springs in this or any embodiment shown or described herein.

**[00133]** Although Fig. 18A illustrates the sections extending the full length of the comfort layer longitudinally or from head-to-foot, the sections may extend the full width of the comfort layer transversely or from side-to-side. In such an embodiment, each of the pocketed mini coil springs of each of the rows would be identical. The pocketed mini coil springs within the rows of the tall sections would be different than the pocketed mini coil springs within the rows of the short sections.

**[00134]** Fig. 18B illustrates another posturized comfort layer 16f having a center section 40f and two end sections 42f on opposite sides of the center section 40f. Each of the three sections 40f, 42f is generally rectangular shaped and approximately the same size. However, any one of the sections may be a different size than any other section. For example, the end sections 42f may be a different size than the center section 40f. The drawings are not intended to be limiting.

**[00135]** Each of the end sections 42f is illustrated having four tall sections 98, adjacent tall sections 98 being separated by a longitudinally extending short section 100 of short pocketed mini coil springs 46. The pocketed mini coil springs of each of the tall sections 98 are tall pocketed mini coil springs 44, thus resulting in firmer sections than the short sections 100 of each of the end sections 100 of posturized comfort layer 16f. Each of the tall sections 98 of each end section 42f is generally rectangular shaped and approximately the same size. However, any section may be a different size than any other section. For example, any one of the tall sections 98 may be a different size than any other tall section in one or both end sections 42f.

**[00136]** Although Fig. 18B shows each short section 100 of each end section 42f comprising only one longitudinally extending partial column of short pocketed mini coil springs 46 between adjacent tall sections 98, one or more short sections 100 may comprise two or more longitudinally extending partial columns of short pocketed mini coil springs 46 between adjacent tall sections 98 in one or both end sections 42f. As

shown in Fig. 18B, each longitudinally extending partial column(s) 100 of short pocketed mini coil springs 46 between adjacent tall sections 98 is known in the art as a spacer partial column(s) with the benefits described above. Although Fig. 18B shows each tall section 98 comprising four partial columns of tall pocketed mini coil springs 44, each tall section 98 may comprise any desired number of partial columns of tall pocketed mini coil springs. The drawings are not intended to be limiting.

**[00137]** As best shown in Fig. 18B, the pocketed mini coil springs 44, 46 are arranged in a matrix of aligned transversely extending rows 48f extending from side-to-side and longitudinally extending columns 50f extending from head-to-foot. Each of the pocketed mini coil springs of each of the end sections 42f is illustrated being a tall mini coil spring 44, as described herein and shown in Fig. 5C, except for the pocketed mini coil springs 46 of the short sections 100 within each end section 42f. Each of the pocketed mini coil springs of each short section 100 and is illustrated being a column of short pocketed mini coil springs 46, as described herein and shown in Fig. 6C. In place of tall pocketed mini coil springs 44, tall pocketed mini coil springs, like tall pocketed mini coil springs 56 shown in Fig. 7C or tall pocketed mini coil springs 62 shown in Fig. 9C, may be used in any of the tall sections 94 of posturized comfort layer 16e. Similarly, in place of short pocketed mini coil springs 46, short pocketed mini coil springs, like short pocketed mini coil springs 58 shown in Fig. 8C or short pocketed mini coil springs 66 shown in Fig. 10C, may be used in any of the short sections 100 or 40f of posturized comfort layer 16f. As best shown in Fig. 18B, each transversely extending row 48f of each end section 42f of pocketed mini coil springs is identical and comprises short and tall pocketed mini coil springs 44, 46. Each transversely extending row 48f of center section 40f of pocketed mini coil springs is identical and comprises solely short pocketed mini coil springs 46.

**[00138]** Although Fig. 18B illustrates the pocketed mini coil springs having rectangular weld seams, circular weld seams may be incorporated into the pocketed mini coil springs in this or any embodiment shown or described herein. Although Fig. 18B illustrates only end sections 42f having spacer partial columns, it is within the scope of the invention that only center section 40f have spacer partial columns and end sections 42f lack spacer partial columns.

**[00139]** Fig. 18C illustrates another posturized comfort layer 16g having four short sections 102 and three tall sections 104, each of the sections 102, 104 extending the full length of the posturized comfort layer 16g. Adjacent short sections 102 are separated by a longitudinally extending tall section 104 of tall pocketed mini coil springs

44. The pocketed mini coil springs of each of the short sections 102 are short pocketed mini coil springs 46, thus resulting in softer sections than the tall sections of the posturized comfort layer 16g. Each of the short sections 102 is generally rectangular shaped, comprises multiple columns and is approximately the same size. However, any one of the sections may be a different size than any of the other sections. For example, any one of the short sections 102 may be a different size than any other short section.

**[00140]** Although Fig. 18C shows each tall section 104 comprising only one longitudinally extending column of tall pocketed mini coil springs 44 between adjacent short sections 102, one or more tall sections 104 may comprise two or more longitudinally extending columns of tall pocketed mini coil springs 44 between adjacent short sections 102. As shown in Fig. 18C, each longitudinally extending column(s) of tall pocketed mini coil springs 44 between adjacent short sections 102 is known in the art as a spacer column(s) with the benefits described herein. Similarly, although Fig. 18C shows each short section 102 comprising four columns of short pocketed mini coil springs 46, each short section may comprise any desired number of columns of short pocketed mini coil springs. Although Fig. 18C shows four short sections 102 and three tall sections 104, such a posturized comfort layer may have any number of tall sections and short sections. The sections may extend from side-to-side rather than from head-to-foot as shown in Fig. 18C, in which case each section would comprise multiple rows of pocketed mini coil springs of a desired height. The drawings are not intended to be limiting.

**[00141]** As best shown in Fig. 18C, the pocketed mini coil springs 44, 46 are arranged in a matrix of aligned transversely extending rows 48g extending from side-to-side and longitudinally extending columns 50g extending from head-to-foot. In this embodiment, each of the pocketed mini coil springs along each of the columns is identical. However, the pocketed mini coil springs within the columns of the tall sections are different than the pocketed mini coil springs within the columns of the short sections. Each of the pocketed mini coil springs of each of the short sections 102 is illustrated being a short mini coil spring 46, as described herein and shown in Fig. 6C. Each of the pocketed mini coil springs of each tall section 104 is illustrated being a column of tall pocketed mini coil springs 44, as described herein and shown in Fig. 5C. In place of tall pocketed mini coil springs 44, tall pocketed mini coil springs, like tall pocketed mini coil springs 56 shown in Fig. 7C or tall pocketed mini coil springs 62 shown in Fig. 9C, may be used in any of the tall sections 104 of posturized comfort layer 16g. Similarly, in place of short pocketed mini coil springs 46, short pocketed mini

coil springs, like short pocketed mini coil springs 58 shown in Fig. 8C or short pocketed mini coil springs 66 shown in Fig. 10C, may be used in any of the short sections 102 of posturized comfort layer 16g.

**[00142]** Although Fig. 18C illustrates the pocketed mini coil springs having rectangular weld seams, circular weld seams may be incorporated into the pocketed mini coil springs in this or any embodiment shown or described herein.

**[00143]** Although Fig. 18C illustrates the sections extending the full length of the comfort layer longitudinally or from head-to-foot, the sections may extend the full width of the comfort layer transversely or from side-to-side. In such an embodiment, each of the pocketed mini coil springs of each of the rows would be identical. The pocketed mini coil springs within the rows of the tall sections would be different than the pocketed mini coil springs within the rows of the short sections.

**[00144]** Fig. 18D illustrates another posturized comfort layer 16h having a center section 40h and two end sections 42h on opposite sides of the center section 40h. Each of the three sections 40h, 42h is generally rectangular shaped and approximately the same size. However, any one of the sections may be a different size than any of the other sections. For example, the end sections 42h may be a different size than the center section 40h. The drawings are not intended to be limiting.

**[00145]** Each of the end sections 42h is illustrated having four short sections 106, adjacent short sections 106 being separated by a longitudinally extending tall section 108 of tall pocketed mini coil springs 44. The pocketed mini coil springs of each of the tall sections 108 are tall pocketed mini coil springs 44 thus resulting in firmer sections than the short sections 106 of the end sections 42h of posturized comfort layer 16h. Each of the short sections 106 of each end section 42h is generally rectangular shaped and approximately the same size. However, any one of the short sections 106 may be a different size than any other short section in one or both end sections 42h.

**[00146]** Although Fig. 18D shows each tall section 108 of each end section 42h comprising only one longitudinally extending partial column of tall pocketed mini coil springs 44 between adjacent short sections 106, one or more tall sections 108 may comprise two or more longitudinally extending partial columns of tall pocketed mini coil springs 44 between adjacent short sections 106 in one or both end sections 42h. As shown in Fig. 18D, each longitudinally extending partial column(s) of tall pocketed mini coil springs 44 between adjacent short sections 106 is known in the art as a spacer partial column(s) with the benefits described above. Similarly, although Fig. 18D shows each short section 106 comprising four partial columns of short pocketed mini coil

springs 46, each short section may comprise any desired number of partial columns of short pocketed mini coil springs. The drawings are not intended to be limiting.

**[00147]** As best shown in Fig. 18D, the pocketed mini coil springs 44, 46 are arranged in a matrix of aligned transversely extending rows 48h extending from side-to-side and longitudinally extending columns 50h extending from head-to-foot. Each of the pocketed mini coil springs of the center section 40h is illustrated being a tall mini coil spring 44, as described herein and shown in Fig. 5C. Each of the pocketed mini coil springs of each of the end sections 42h is illustrated being short mini coil springs 46, except for the tall pocketed mini coil springs 44 of the tall sections 108 within each end section 42h. In place of tall pocketed mini coil springs 44, tall pocketed mini coil springs 56 shown in Fig. 7C or tall pocketed mini coil springs 62 shown in Fig. 9C may be used in any of the tall sections 40h, 108 of posturized comfort layer 16h. Similarly, in place of short pocketed mini coil springs 46, short pocketed mini coil springs 58 shown in Fig. 8C or short pocketed mini coil springs 66 shown in Fig. 10C may be used in any of the short sections 106 of posturized comfort layer 16h. As best shown in Fig. 18D, each transversely extending row 48h of each end section 42f of pocketed mini coil springs is identical and comprises short and tall pocketed mini coil springs 44, 46. Each transversely extending row 48h of center section 40h of pocketed mini coil springs is identical and comprises solely tall pocketed mini coil springs 44.

**[00148]** Although Fig. 18D illustrates the pocketed mini coil springs having rectangular weld seams, circular weld seams may be incorporated into the pocketed mini coil springs in this or any embodiment shown or described herein. Although Fig. 18D illustrates only end sections 42h having spacer partial columns, it is within the scope of the invention that only center section 40h have spacer partial columns and end sections 42f lack spacer partial columns.

**[00149]** Figs. 19, 19A and 19B illustrate another comfort layer 16i. Comfort layer 16i comprises pocketed mini coil springs 44, 46 arranged in a matrix of aligned transversely extending rows 48i extending from side-to-side and longitudinally extending columns 50i extending from head-to-foot. Tall and short pocketed mini coil springs 44, 46, respectively, alternate along each row 48i and along each column 50i. In other words, every other pocketed mini coil spring is a tall pocketed mini coil spring 44 along each row 48i and along each column 50i. Similarly, every other pocketed mini coil spring is a short pocketed mini coil spring 46 along each row 48i and along each column 50i. One result of such an arrangement is a comfort layer having a uniform

firmness or feel across the full width and full length of the comfort layer. In the industry, this configuration is known as a “checkerboard” pattern.

**[00150]** Each of the tall pocketed mini coil springs 44 is as described herein and shown in Fig. 5C. Each of the short pocketed mini coil springs 46 is as described herein and shown in Fig. 6C. In place of tall pocketed mini coil springs 44, tall pocketed mini coil springs 56 shown in Fig. 7C or tall pocketed mini coil springs 62 shown in Fig. 9C may be used in comfort layer 16i. Similarly, in place of short pocketed mini coil springs 46, short pocketed mini coil springs 58 shown in Fig. 8C or short pocketed mini coil springs 66 shown in Fig. 10C may be used in comfort layer 16i. Regardless of which tall and short pocketed mini coil springs are used, the diameter of the mini coil springs of the tall pocketed mini coil springs is less than the diameter of the mini coil springs of the short pocketed mini coil springs. Similarly, regardless of which tall and short pocketed mini coil springs are used, the pocketed height of the tall pocketed mini coil springs is greater than the pocketed height of the short pocketed mini coil springs.

**[00151]** Fig. 19B illustrates the components of comfort layer 16i shown in Figs. 19 and 19A. The comfort layer 16i comprises a first or upper piece of fabric 22 and a second or lower piece of fabric 24 with a plurality of mini coil springs 26, 28 therebetween. The fabric pieces 22, 24 are joined together with rectangular weld seams 30, each rectangular weld seam 30 surrounding one of the mini coil springs 26 or 28. Each rectangular weld seam 30 comprises multiple straight or linear weld segments 32 with gaps 34 therebetween. The first and second pieces of fabric 22, 24 are joined together along each straight or linear weld segment 32 of each rectangular seam 30. The first and second pieces of fabric 22, 24 are not joined together along each gap 34 between adjacent weld segments 32 of each rectangular seam 30. The straight or linear weld segments 32 are strategically placed around a mini coil spring 26, 28 and create the rectangular seam 30. The two pieces of fabric 22, 24, in combination with one of the rectangular weld seams 30, define a pocket 36, 38 inside of which is at least one mini coil spring 26, 28, respectively. See Figs. 19A and 19B.

**[00152]** Figs. 20, 20A and 20B illustrate another comfort layer 16j having pocketed mini coil springs 44c, 46c with circular welds, rather than rectangular welds, joining the first and second pieces of fabric 22, 24. Comfort layer 16j comprises pocketed mini coil springs 44c, 46c arranged in a matrix of aligned transversely extending rows 48j extending from side-to-side and longitudinally extending columns 50j extending from head-to-foot. Tall and short pocketed mini coil springs 44c, 46c, respectively, alternate along each row 48i and along each column 50i. In other words, every other pocketed

mini coil spring is a tall pocketed mini coil spring 44 along each row 48j and along each column 50j. Similarly, every other pocketed mini coil spring is a short pocketed mini coil spring 46 along each row 48j and along each column 50j. One result of such an arrangement is a comfort layer having a uniform firmness or feel across the full width and full length of the comfort layer. In the industry, this configuration is known as a “checkerboard” pattern.

**[00153]** Each of the tall pocketed mini coil springs 44c is as described herein and shown in Fig. 13A. Each of the short pocketed mini coil springs 46c is as described herein and shown in Fig. 13A. In place of tall pocketed mini coil springs 44c, tall pocketed mini coil springs 56 shown in Fig. 7C or tall pocketed mini coil springs 62 shown in Fig. 9C may be used in comfort layer 16j. Similarly, in place of short pocketed mini coil springs 46c, short pocketed mini coil springs, like short pocketed mini coil springs 58 shown in Fig. 8C or short pocketed mini coil springs 66 shown in Fig. 10C, may be used in comfort layer 16i. Regardless of which tall and short pocketed mini coil springs are used, the diameter of the mini coil springs of the tall pocketed mini coil springs is less than the diameter of the mini coil springs of the short pocketed mini coil springs. Similarly, regardless of which tall and short pocketed mini coil springs are used, the pocketed height of the tall pocketed mini coil springs is greater than the pocketed height of the short pocketed mini coil springs.

**[00154]** Fig. 20B illustrates the components of comfort layer 16j shown in Figs. 20, 20A and 20B. The comfort layer 16j comprises a first or upper piece of fabric 22 and a second or lower piece of fabric 24 with a plurality of mini coil springs 26, 28 therebetween. The fabric pieces 22, 24 are joined together with large circular weld seams 74, each circular weld seam 74 surrounding a mini coil spring 26, 28. Each circular weld seam 74 comprises multiple arced or curved weld segments 76 with gaps 78 therebetween. The first and second pieces of fabric 22, 24 are joined together along each arced or curved weld segment 76 of each circular weld seam 74. The first and second pieces of fabric 22, 24 are not joined together along each gap 78 between adjacent weld segments 76 of each circular seam 74. The curved weld segments 76 are strategically placed around a mini coil spring 26, 28 and create the circular seam 74. The two pieces of fabric 22, 24, in combination with one of the circular weld seams 74, define a cylindrical-shaped pocket 36, 38 inside of which is at least one mini coil spring 26, 28, respectively. See Figs. 20A and 20B.

**[00155]** The embodiment of comfort layer 16j shown in Figs. 20, 20A and 20B illustrates all the circular weld seams 74 being the same diameter. The difference in the

height of the pocketed mini coil springs 44, 46 is due to the different mini coil springs 26, 28 being inside the pockets 36, 38, respectively. As stated herein, within the scope of the invention, the mini coil springs within a comfort layer having a checkerboard arrangement may be identical, but the diameter of the circular weld seams different to create pockets of different heights.

**[00156]** Although the drawings show a certain size of the curved weld segments 76 of circular weld seams 74, the size of the curved weld segments 76 of circular weld seams 74 are not intended to be limited by the illustrations; they may be any desired size. Similarly, although the drawings show the circular weld seams 74 having a certain diameter, the diameter of the illustrated circular weld seams 74 is not intended to be limiting.

**[00157]** Figs. 21, 21A and 21B illustrate another comfort layer 16k having the same pocketed mini coil springs 44c, 46c as the comfort layer 16j shown in Figs. 20, 20A and 20B with circular welds joining the first and second pieces of fabric 22, 24. The components of comfort layer 16k are the same as the components of comfort layer 16j. However, the orientation of the pocketed mini coil springs 44c, 46c in comfort layer 16k is different than the orientation of the pocketed mini coil springs 44c, 46c in comfort layer 16j.

**[00158]** Comfort layer 16k comprises pocketed mini coil springs 44c, 46c arranged in a matrix of aligned transversely extending rows 48k extending from side-to-side and longitudinally extending columns 50k extending from head-to-foot. Tall and short pocketed mini coil springs 44c, 46c, respectively, alternate along each row 48k and along each column 50k. In other words, every other pocketed mini coil spring is a tall pocketed mini coil spring 44 along each row 48k and along each column 50k. Similarly, every other pocketed mini coil spring is a short pocketed mini coil spring 46c along each row 48k and along each column 50k. The result of such an arrangement is a comfort layer having a uniform firmness or feel across the full width and full length of the comfort layer. As best illustrated in Fig. 21A, the pocketed mini coil springs of one column are offset from, rather than aligned with, the pocketed mini coil springs of the adjacent columns, which is a different configuration than the checkerboard configuration shown in comfort layer 16j illustrated in Figs. 20, 20A and 20B. This configuration of pocketed mini coil springs is known in the industry as a nested configuration.

**[00159]** Each of the tall pocketed mini coil springs 44c is as described herein and shown in Fig. 13A. Each of the short pocketed mini coil springs 46c is as described herein and shown in Fig. 13A. In place of tall pocketed mini coil springs 44c, tall

pocketed mini coil springs, like tall pocketed mini coil springs 56 shown in Fig. 7C or tall pocketed mini coil springs 62 shown in Fig. 9C, may be used in comfort layer 16k. Similarly, in place of short pocketed mini coil springs 46c, short pocketed mini coil springs like short pocketed mini coil springs 58 shown in Fig. 8C or short pocketed mini coil springs 66 shown in Fig. 10C may be used in comfort layer 16k. Regardless of which tall and short pocketed mini coil springs are used, the diameter of the mini coil springs of the tall pocketed mini coil springs is less than the diameter of the mini coil springs of the short pocketed mini coil springs. Similarly, regardless of which tall and short pocketed mini coil springs are used, the pocketed height of the tall pocketed mini coil springs is greater than the pocketed height of the short pocketed mini coil springs.

**[00160]** The embodiment of comfort layer 16j shown in Figs. 20, 20A and 20B illustrates all the circular weld seams 74 being the same diameter. The difference in the height of the pocketed mini coil springs 44, 46 is due to the different mini coil springs 26, 28 being inside the pockets 36, 38, respectively. It is within the scope of the invention that the mini coil springs within comfort layer 16j shown in Figs. 21, 21A and 21B be identical, but the diameter of the circular weld seams of pocketed mini coil springs 44c, 46c within comfort layer 16j be different to create pocketed mini coil springs of different heights.

**[00161]** Figs. 22, 22A and 22B illustrate another comfort layer 16l. Comfort layer 16l comprises pocketed mini coil springs 44, 46 arranged in a matrix of aligned transversely extending rows 48l extending from side-to-side and longitudinally extending columns 50l extending from head-to-foot. Tall and short pocketed mini coil springs 44, 46, respectively, extend in a repeating pattern along each row 48l and along each column 50l. In the illustrated embodiment, every third pocketed mini coil spring is a short pocketed mini coil spring 46 along each row 48l and along each column 50l. Similarly, between a pair of adjacent short pocketed mini coil springs 46 are two tall pocketed mini coil springs 44 along each row 48l and along each column 50l. One result of such an arrangement is a comfort layer having a uniform firmness or feel across the full width and full length of the comfort layer. Although one repeating pattern is illustrated, other repeating patterns are within the scope of the invention regardless of whether along one or more columns or one or more rows. For example, a repeating pattern of tall, tall, short, short may extend along each column or row. This example is merely one of many examples.

**[00162]** Each of the tall pocketed mini coil springs 44 is as described herein and shown in Fig. 5C. Each of the short pocketed mini coil springs 46 is as described

herein and shown in Fig. 6C. In place of tall pocketed mini coil springs 44, tall pocketed mini coil springs 56 shown in Fig. 7C or tall pocketed mini coil springs 62 shown in Fig. 9C may be used in comfort layer 16l. Similarly, in place of short pocketed mini coil springs 46, short pocketed mini coil springs 58 shown in Fig. 8C or short pocketed mini coil springs 66 shown in Fig. 10C may be used in comfort layer 16l. Regardless of which tall and short pocketed mini coil springs are used, the diameter of the mini coil springs of the tall pocketed mini coil springs is less than the diameter of the mini coil springs of the short pocketed mini coil springs. Similarly, regardless of which tall and short pocketed mini coil springs are used, the pocketed height of the tall pocketed mini coil springs is greater than the pocketed height of the short pocketed mini coil springs.

**[00163]** Fig. 22B illustrates the components of comfort layer 16l shown in Figs. 22 and 22A. The comfort layer 16l comprises a first or upper piece of fabric 22 and a second or lower piece of fabric 24 with a plurality of mini coil springs 26, 28 therebetween. The fabric pieces 22, 24 are joined together with rectangular weld seams 30, each rectangular weld seam 30 surrounding one of the mini coil springs 26 or 28. Each rectangular weld seam 30 comprises multiple straight or linear weld segments 32 with gaps 34 therebetween. The first and second pieces of fabric 22, 24 are joined together along each straight or linear weld segment 32 of each rectangular seam 30. The first and second pieces of fabric 22, 24 are not joined together along each gap 34 between adjacent weld segments 32 of each rectangular seam 30. The straight or linear weld segments 32 are strategically placed around a mini coil spring 26, 28 and create the rectangular seam 30. The two pieces of fabric 22, 24, in combination with one of the rectangular weld seams 30, define a pocket 36, 38 inside of which is at least one mini coil spring 26, 28, respectively. See Figs. 22A and 22B. Although not shown, comfort layer 16l may be made with circular welds, either continuous or segmented or any combination thereof. This is true for any of the comfort layers shown or described herein.

**[00164]** Figs. 23, 23A and 23B illustrate another comfort layer 16m. Comfort layer 16m comprises pocketed mini coil springs 44, 46 arranged in a matrix of aligned transversely extending rows 48m extending from side-to-side and longitudinally extending columns 50m extending from head-to-foot. Each of the transversely extending rows 48m extending from side-to-side has pocketed mini coil springs of the same height along the row 48m. In the illustrated embodiment, each third row 48m of pocketed mini coil springs comprises short pocketed mini coil springs 46.

**[00165]** As shown in Fig. 23, along each column 50m, tall, medium and short pocketed mini coil springs 44, 45, 46, respectively, extend in a repeating pattern. In the illustrated embodiment, every third pocketed mini coil spring is a short pocketed mini coil spring 46, every third pocketed mini coil spring is a medium pocketed mini coil spring 45 and every third pocketed mini coil spring is a tall pocketed mini coil spring 44 along each column 50l. The medium pocketed mini coil spring 45 has a pocketed height greater than the pocketed height of the short pocketed mini coil spring 46 and less than the pocketed height of the tall pocketed mini coil spring 44. One result of such an arrangement is a comfort layer having a uniform firmness or feel across the full width and full length of the comfort layer. Although one repeating pattern is illustrated, other repeating patterns are within the scope of the invention regardless of whether along one or more columns or one or more rows. For example, a repeating pattern of tall, tall, medium, medium, short, short may extend along each column or row. This example is merely one of many examples.

**[00166]** Each of the tall pocketed mini coil springs 44 is as described herein and shown in Fig. 5C. Each of the short pocketed mini coil springs 46 is as described herein and shown in Fig. 6C. In place of tall pocketed mini coil springs 44, tall pocketed mini coil springs 56 shown in Fig. 7C or tall pocketed mini coil springs 62 shown in Fig. 9C may be used in comfort layer 16m. Similarly, in place of short pocketed mini coil springs 46, short pocketed mini coil springs 58 shown in Fig. 8C or short pocketed mini coil springs 66 shown in Fig. 10C may be used in comfort layer 16m. Regardless of which tall and short pocketed mini coil springs are used, the diameter of the mini coil springs of the tall pocketed mini coil springs is less than the diameter of the mini coil springs of the short pocketed mini coil springs. Similarly, regardless of which tall and short pocketed mini coil springs are used, the pocketed height of the tall pocketed mini coil springs is greater than the pocketed height of the short pocketed mini coil springs.

**[00167]** Fig. 23B illustrates the components of comfort layer 16m shown in Figs. 23 and 23A. The comfort layer 16m comprises a first or upper piece of fabric 22 and a second or lower piece of fabric 24 with a plurality of mini coil springs 26, 28 therebetween. The fabric pieces 22, 24 are joined together with rectangular weld seams 30, each rectangular weld seam 30 surrounding one of the mini coil springs 26 or 28. Each rectangular weld seam 30 comprises multiple straight or linear weld segments 32 with gaps 34 therebetween. The first and second pieces of fabric 22, 24 are joined together along each straight or linear weld segment 32 of each rectangular seam 30. The first and second pieces of fabric 22, 24 are not joined together along

each gap 34 between adjacent weld segments 32 of each rectangular seam 30. The straight or linear weld segments 32 are strategically placed around a mini coil spring 26, 28 and create the rectangular seam 30. The two pieces of fabric 22, 24, in combination with one of the rectangular weld seams 30, define a pocket 36, 38 inside of which is at least one mini coil spring 26, 28, respectively. See Figs. 23A and 23B. Although not shown, comfort layer 16m may be made with circular welds, either continuous or segmented or any combination thereof. This is true for any of the comfort layers shown or described herein.

**[00168]** While we have described several preferred embodiments of this invention, persons skilled in this art will appreciate that other configurations of comfort layers may be utilized in the practice of this invention. Similarly, such persons will appreciate that each pocket may contain any number of coil springs or other type of spring, made of any desired material. Persons skilled in the art may further appreciate that the segments of the weld seams may be stitched, glued or otherwise adhered or bonded. Therefore, we do not intend to be limited except by the scope of the following appended claims.

We claim:

1. A comfort layer configured to overlay a core of a bedding or seating product, said comfort layer comprising:

a matrix of interconnected pocketed mini coil springs, each pocketed mini coil spring comprising a mini coil spring contained within a fabric pocket, said fabric pocket having a weld seam at least partially around the fabric pocket joining first and second pieces of the fabric pocket;

said comfort layer having at least one tall section and at least one short section, the pocketed mini coil springs of each of the tall sections being a first height and the pocketed mini coil springs of each short section being a second height less than the first height.

2. The comfort layer of claim 1 wherein each weld seam has multiple weld segments.

3. The comfort layer of claim 2 wherein the weld seams are circular, and the weld segments of the pocket are curved.

4. The comfort layer of claim 2 wherein the weld seams are rectangular and the weld segments of the pocket are straight.

5. The comfort layer of claim 1 wherein the mini coil springs of each short section are identical.

6. The comfort layer of claim 1 wherein the mini coil springs within the pocketed mini coil springs of each tall section have a smaller diameter than the diameter of the mini coil springs within the pocketed mini coil springs of each short section.

7. A comfort layer configured to overlay a core of a bedding or seating product, said comfort layer comprising:

a matrix of mini coil springs;

a first piece of fabric on one side of the matrix of mini coil springs;

a second piece of fabric on another side of the matrix of mini coil springs, the first and second pieces of fabric being joined with weld seams at least partially around each of the mini coil springs, thereby forming individual pockets which contain the mini coil springs;

said comfort layer having different sections of different firmness due, at least in part, to the mini coil springs within at least one of the sections having a larger diameter than the mini coil springs within at least one other section of the comfort layer.

8. The comfort layer of claim 7 wherein the weld seams comprise comprising weld segments and gaps between the weld segments and between the first and second pieces of fabric.

9. The comfort layer of claim 8 wherein said weld seams are circular and the weld segments are curved.

10. The comfort layer of claim 7 wherein each of the mini coil springs has the same shape.

11. The comfort layer of claim 7 wherein the pockets of at least two different sections have different heights.

12. The comfort layer of claim 11 wherein at least one of the sections is a tall section and at least one of the sections is a short section, the height of each tall section being greater than the height of each short section, the mini coil springs of each tall section having a smaller diameter than the mini coil springs of each short section.

13. The comfort layer of claim 7 wherein said pocketed mini coil springs are approximately less than 3.0 inches tall.

14. The comfort layer of claim 7 wherein the weld seams are the same size.

15. A comfort layer configured to overlay a core of a bedding or seating product, said comfort layer comprising:

mini coil springs;

a first piece of fabric on one side of the mini coil springs;

a second piece of fabric on another side of the mini coil springs, the first and second pieces of fabric being joined with weld seams at least partially around each of the mini coil springs and individual pockets which contain the mini coil springs;

said comfort layer having different sections of different firmness due, at least in part, to the different sections having different heights.

16. The comfort layer of claim 15 wherein the weld seams comprise weld segments with gaps between the weld segments.

17. The comfort layer of claim 16 wherein the weld seams are circular and the weld segments are curved.

18. The comfort layer of claim 16 wherein the weld seams are rectangular and the weld segments are straight.

19. The comfort layer of claim 16 wherein the gaps are different sizes.

20. The comfort layer of claim 15 wherein the comfort layer has at least three sections.

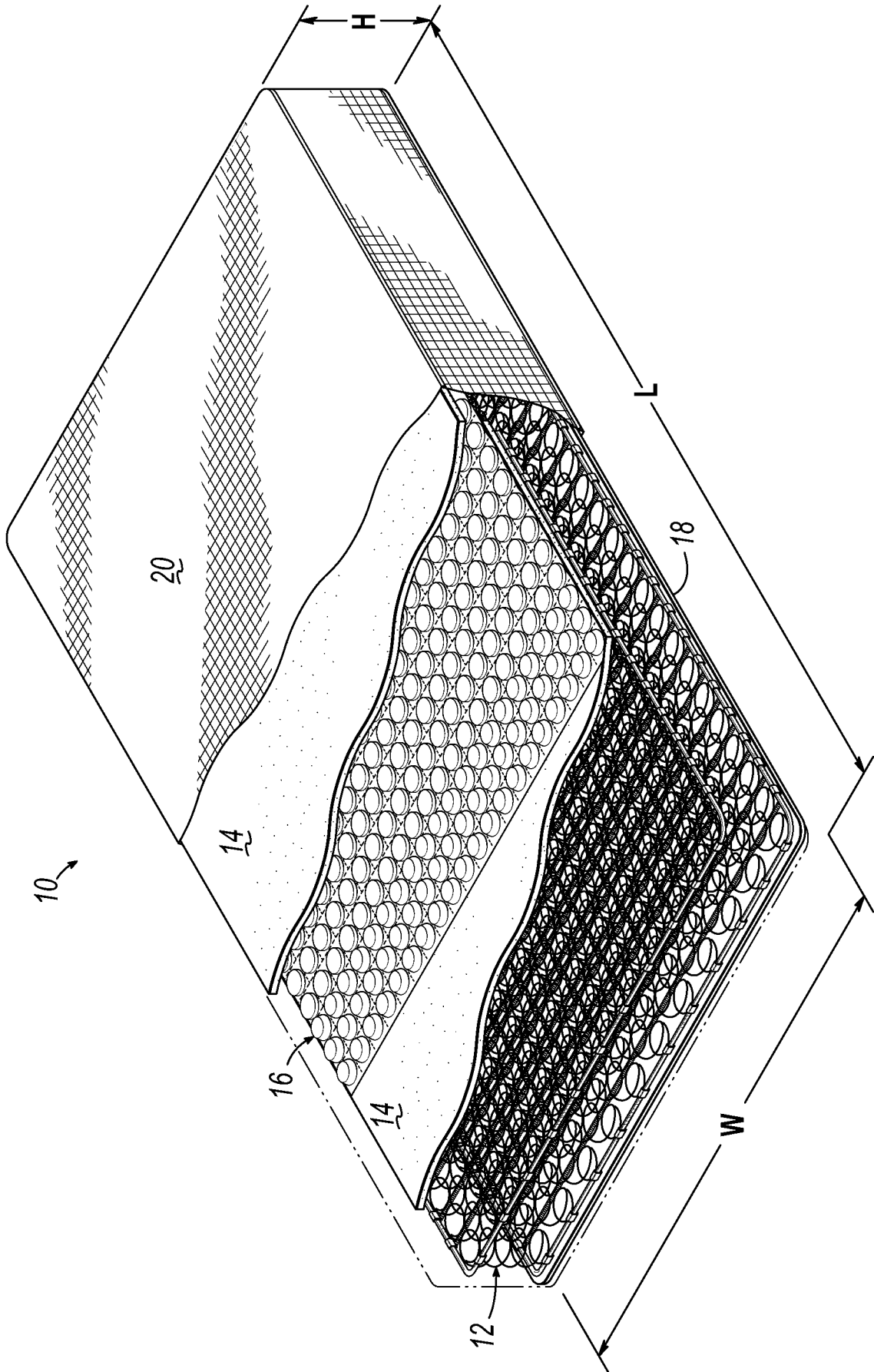

FIG. 1



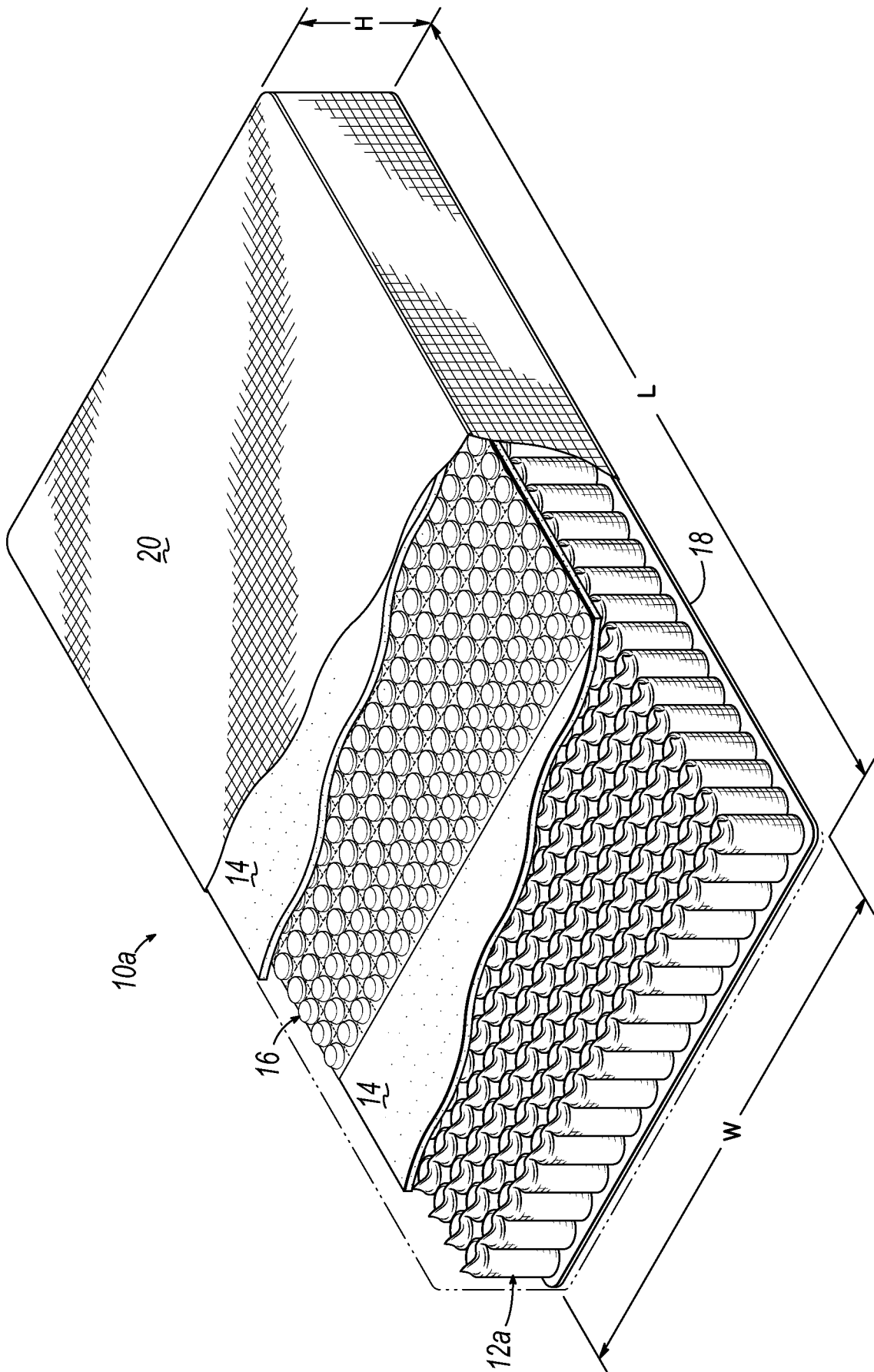

FIG. 1A

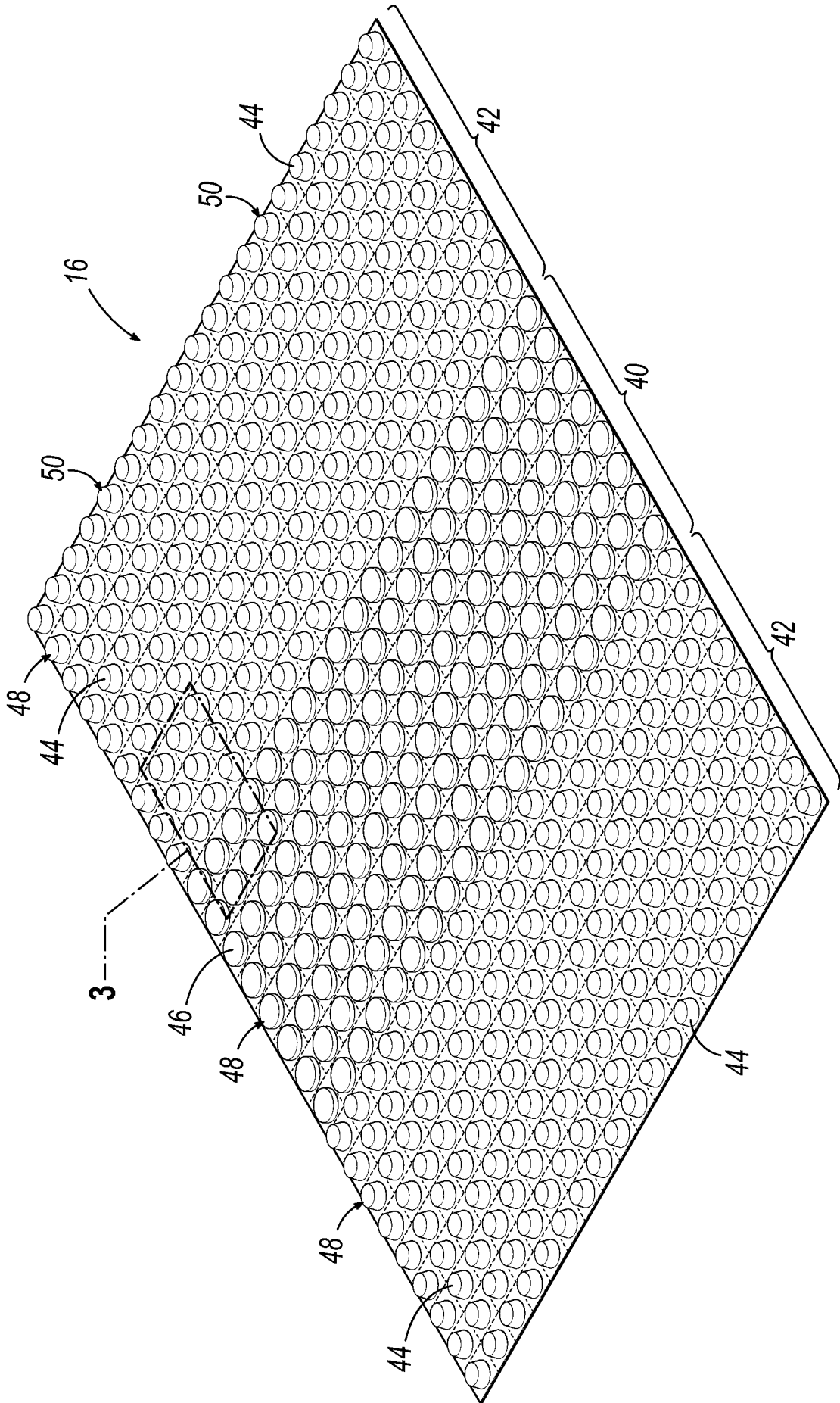

FIG. 2

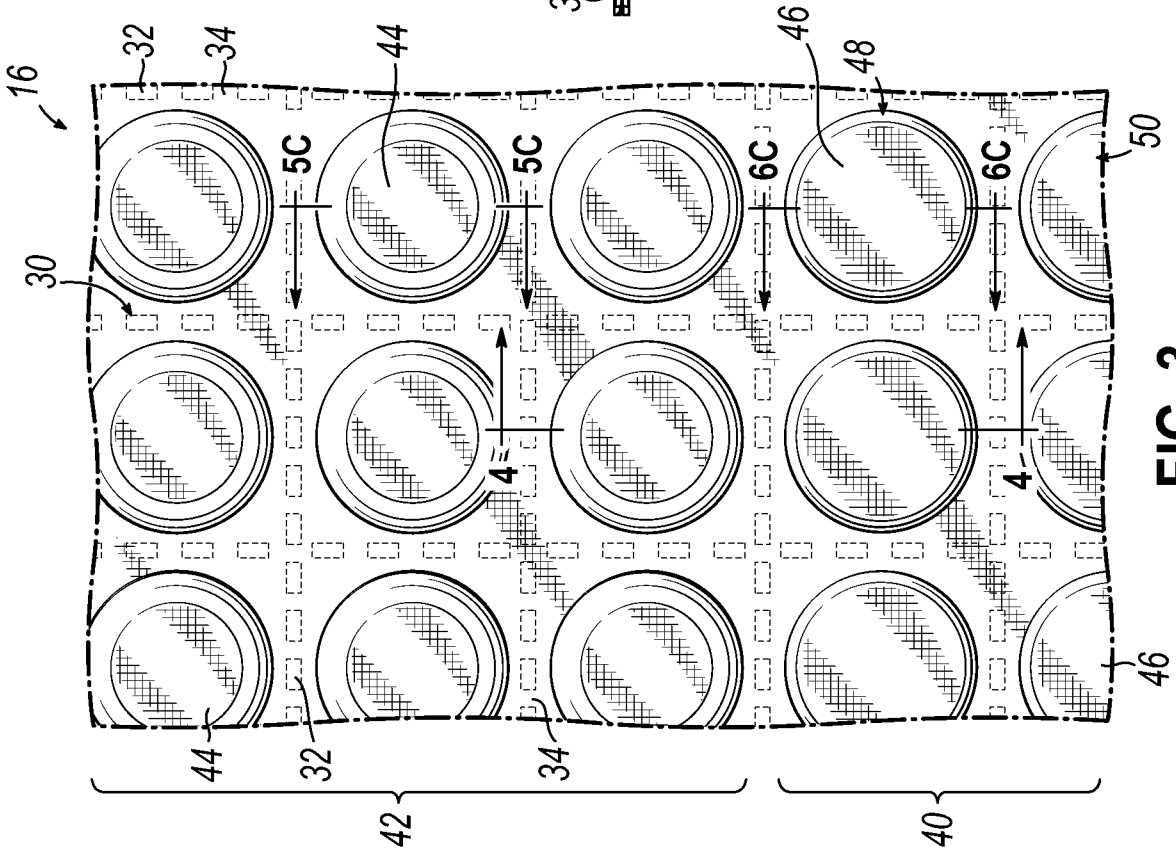

FIG. 3

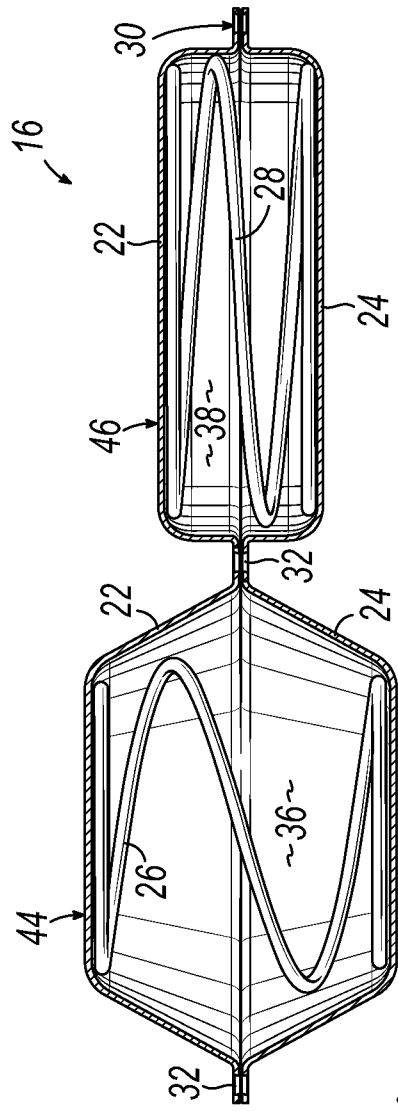

FIG. 4

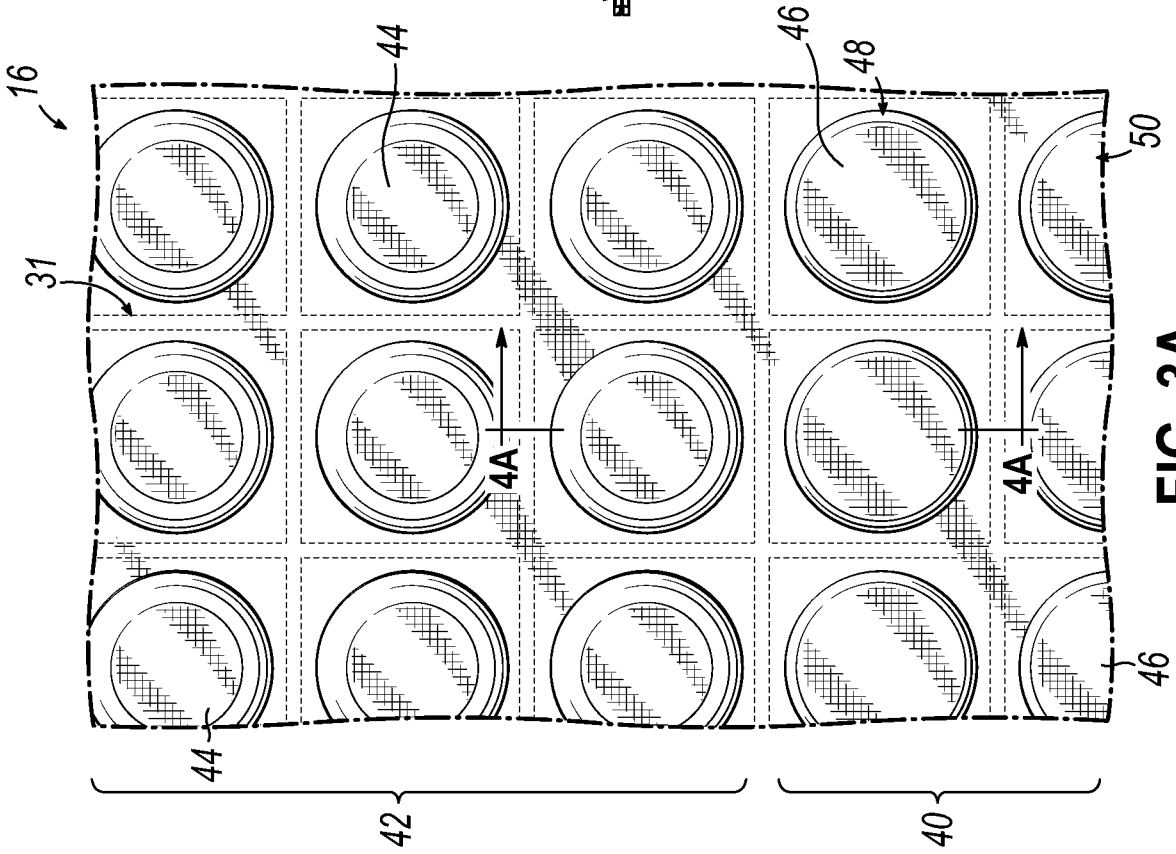

FIG. 3A

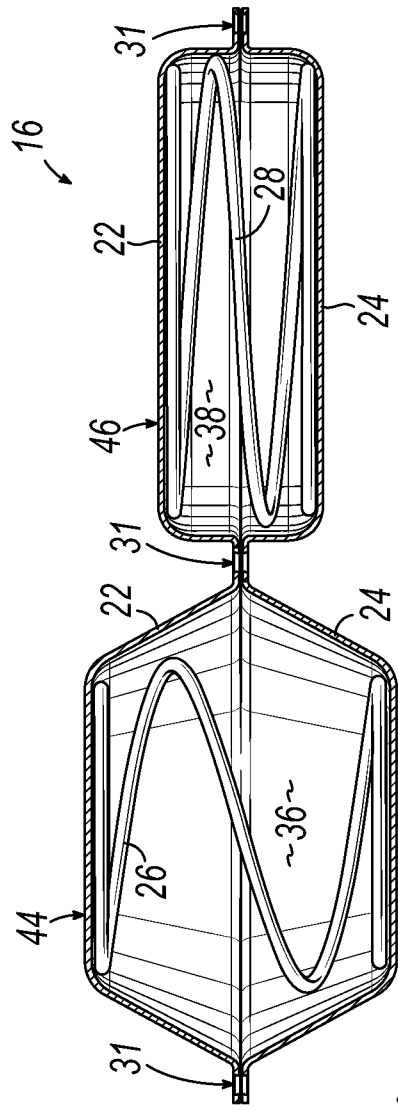

FIG. 4A

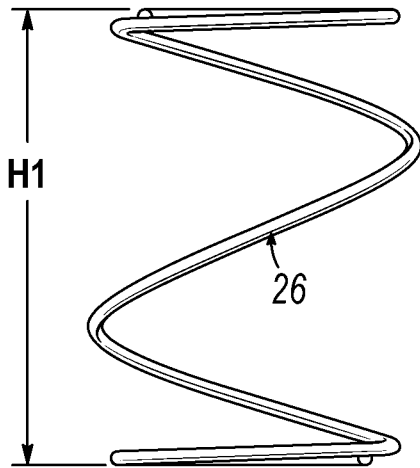

FIG. 5A

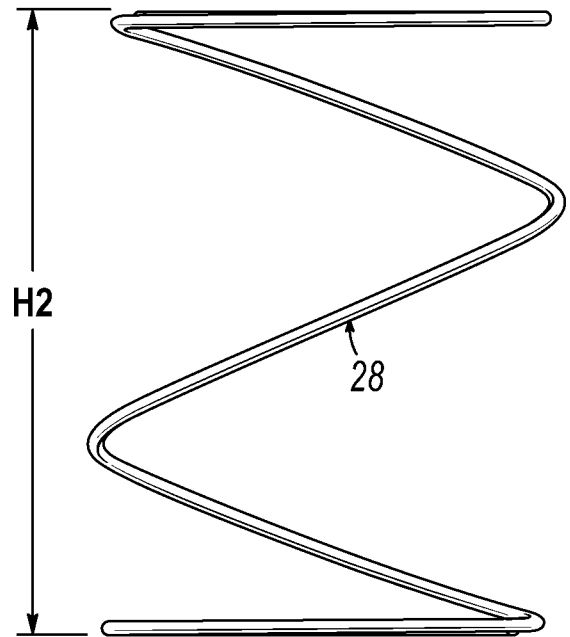

FIG. 6A

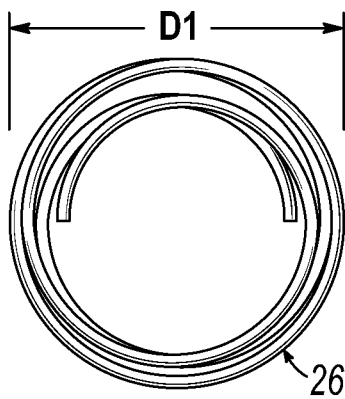

FIG. 5B

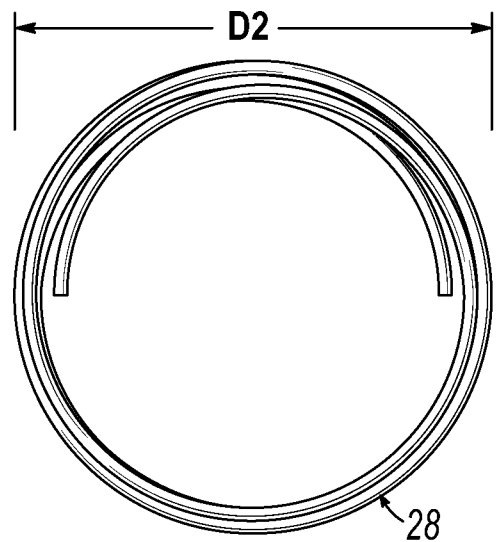

FIG. 6B

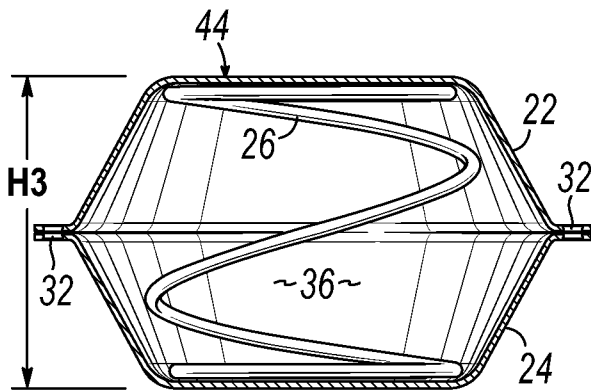

FIG. 5C

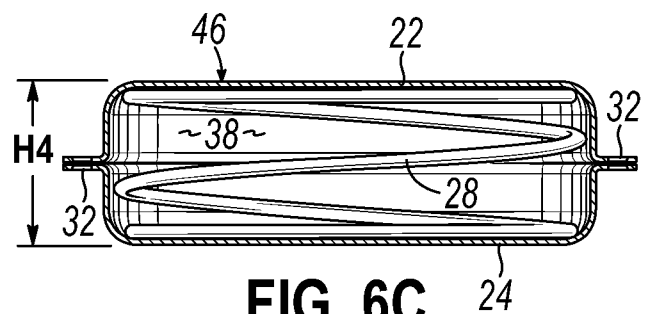

FIG. 6C

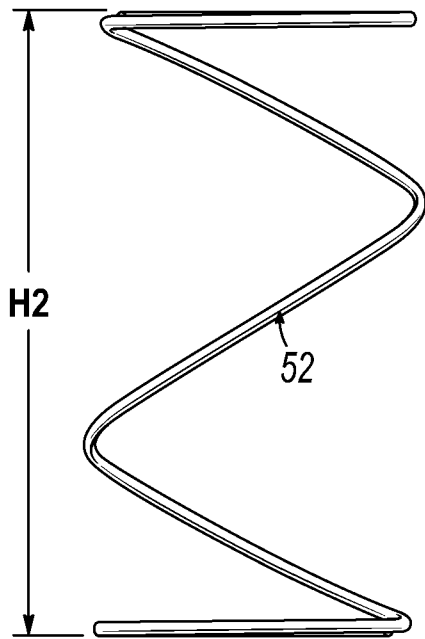

FIG. 7A

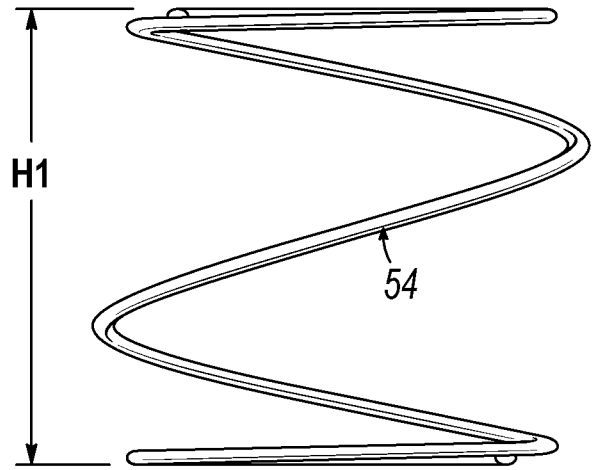

FIG. 8A

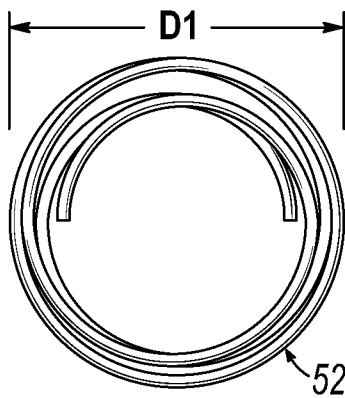

FIG. 7B

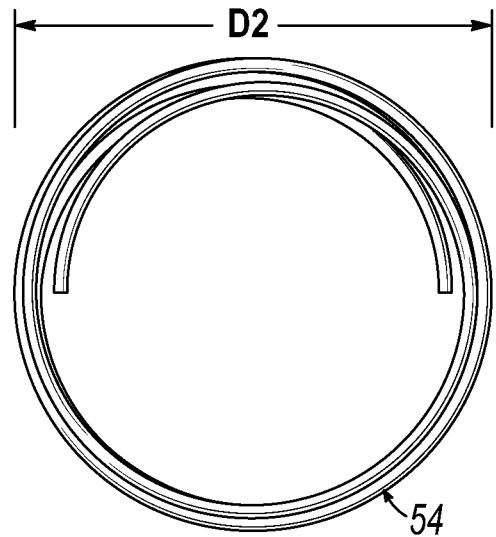

FIG. 8B

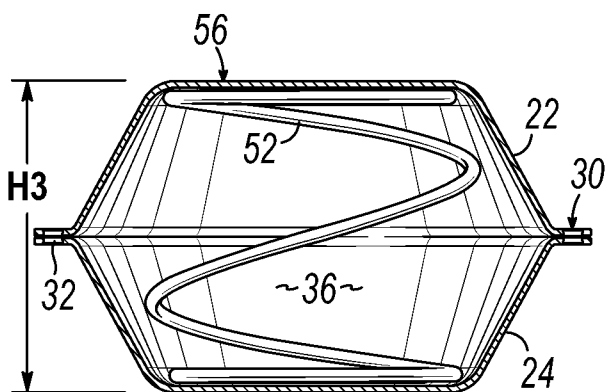

FIG. 7C

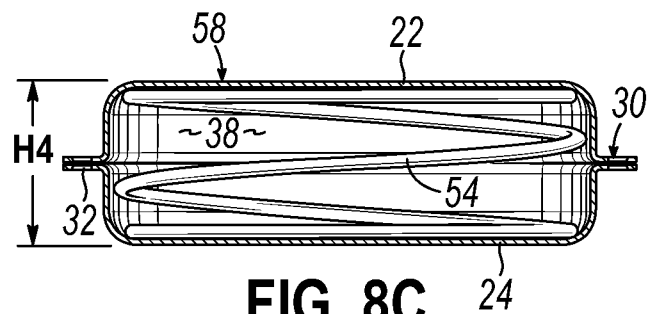

FIG. 8C

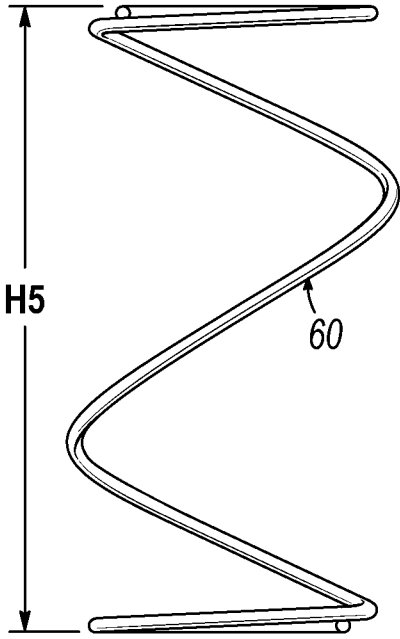

FIG. 9A

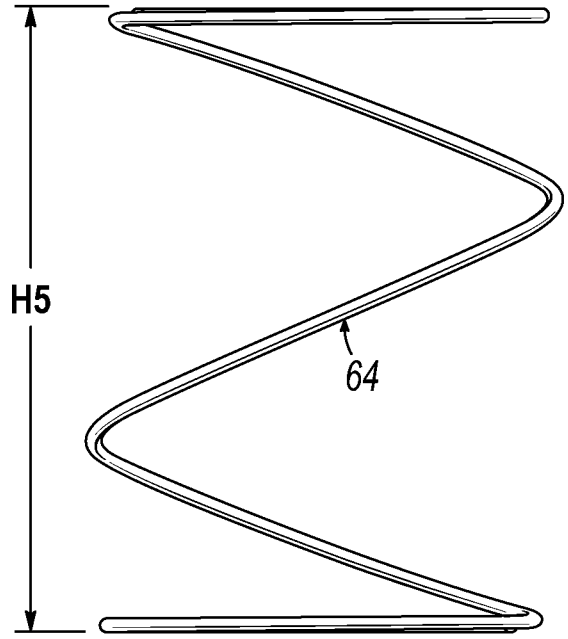

FIG. 10A

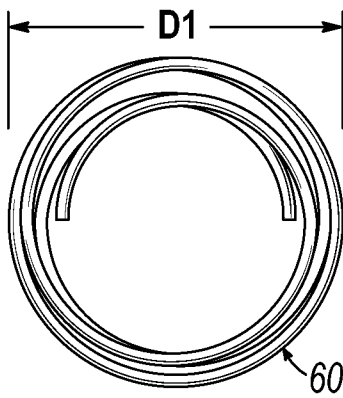

FIG. 9B

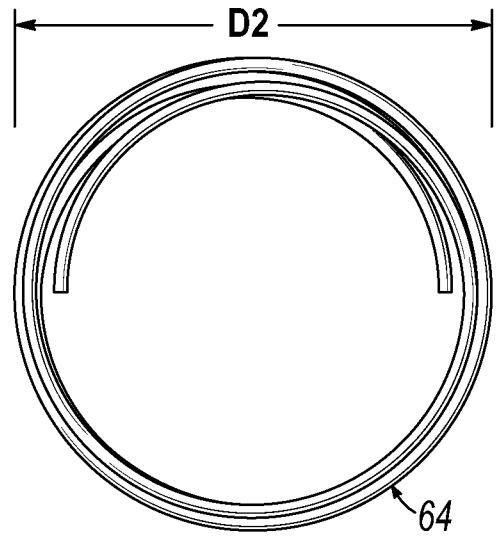

FIG. 10B

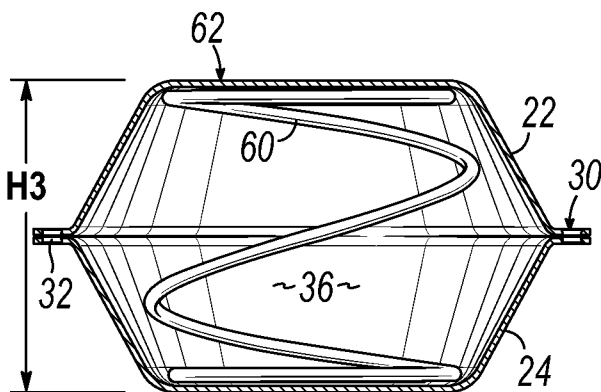

FIG. 9C

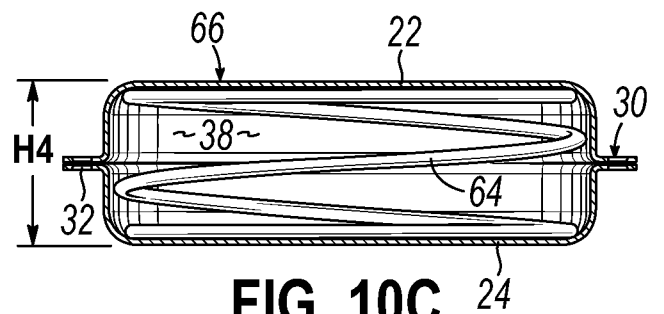

FIG. 10C

9/29

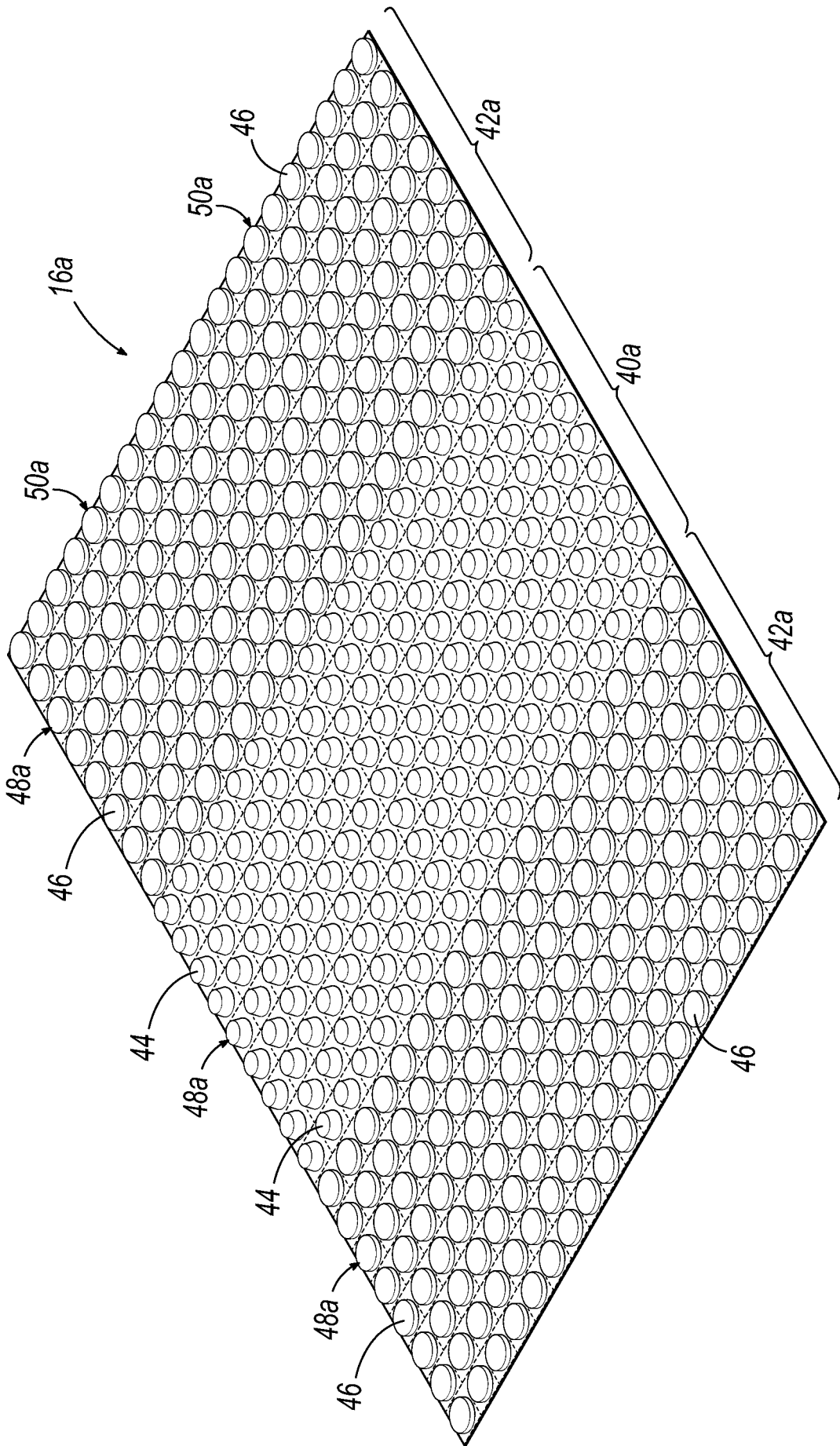

FIG. 11A

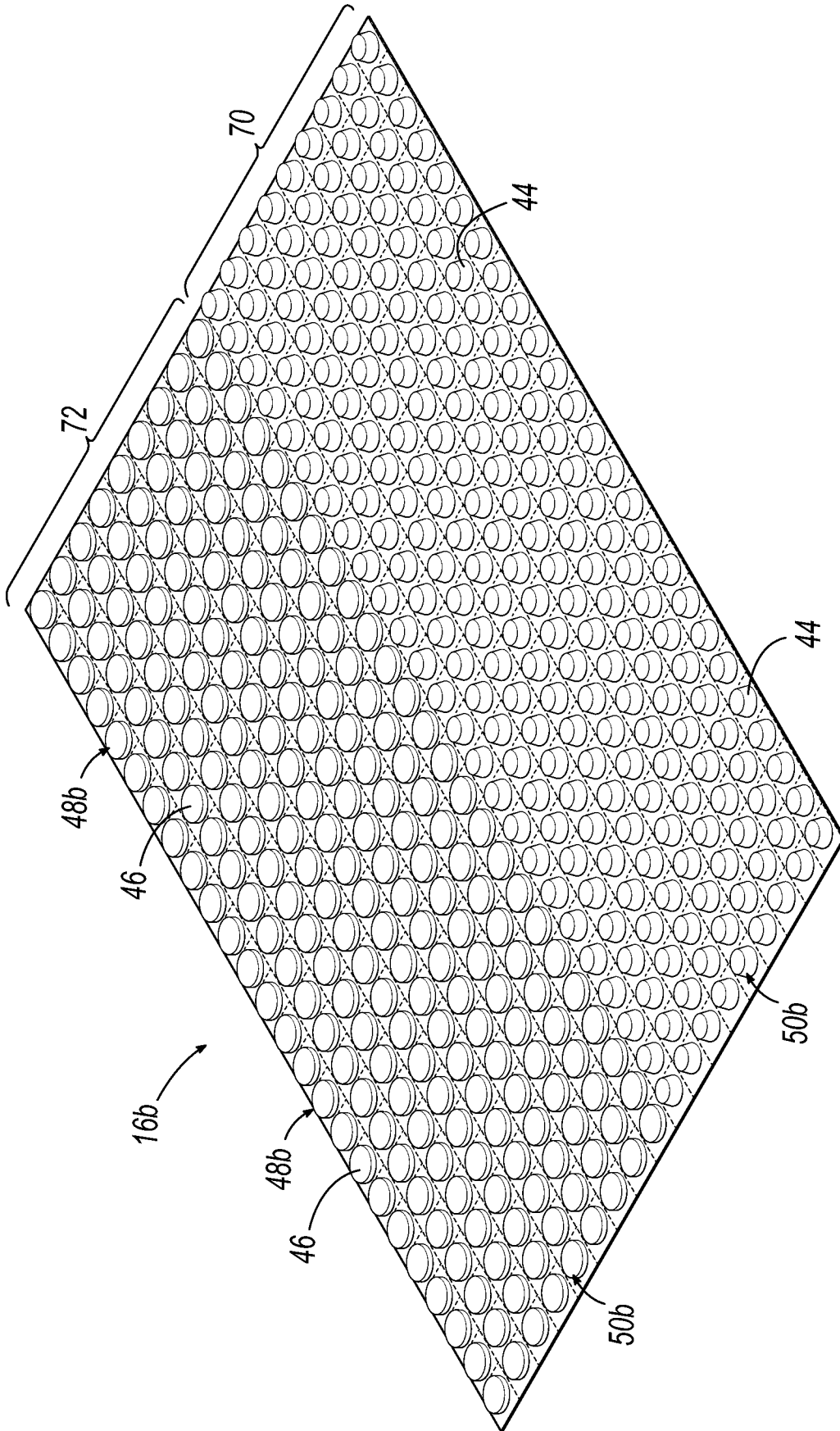

FIG. 11B

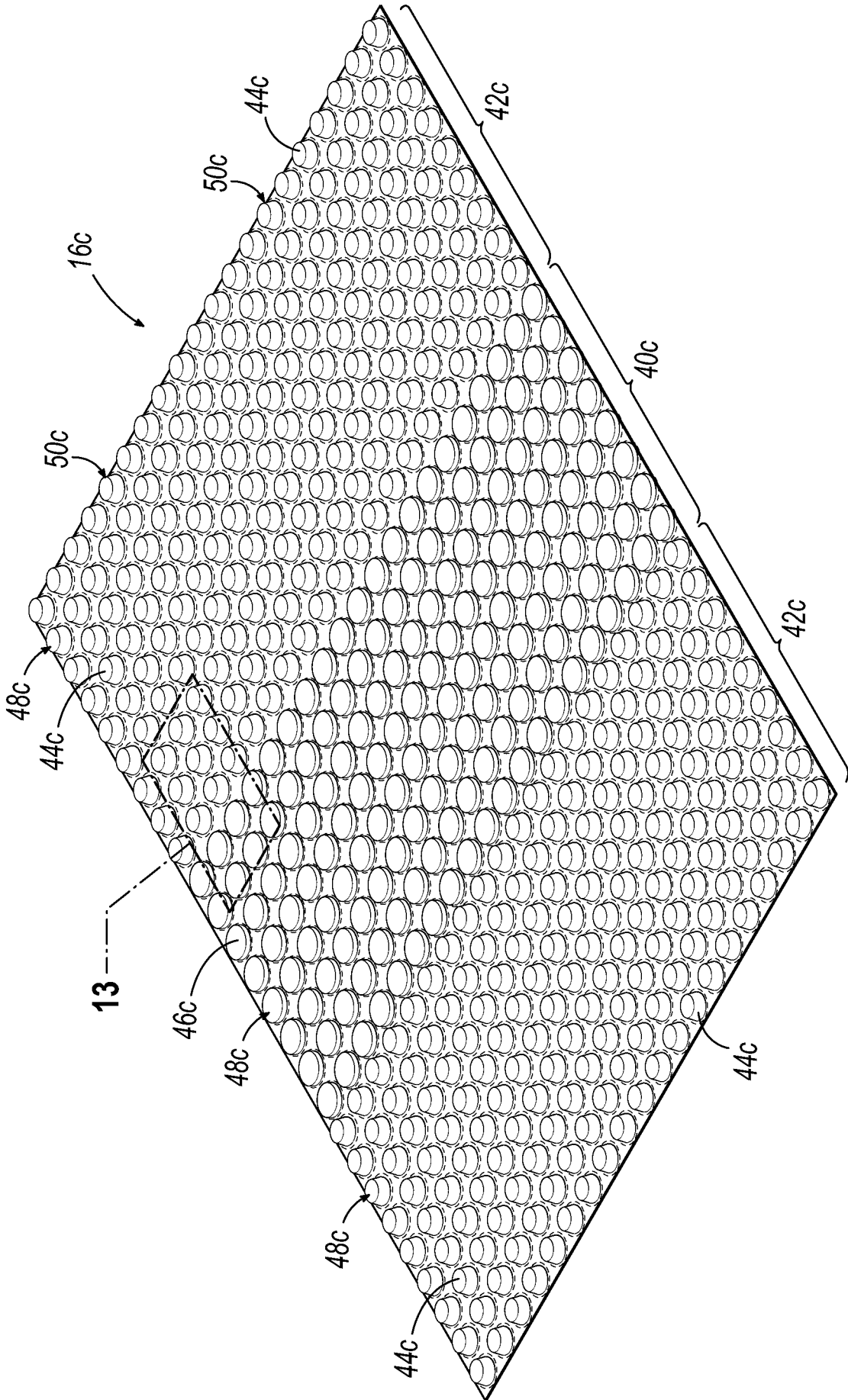

FIG. 12

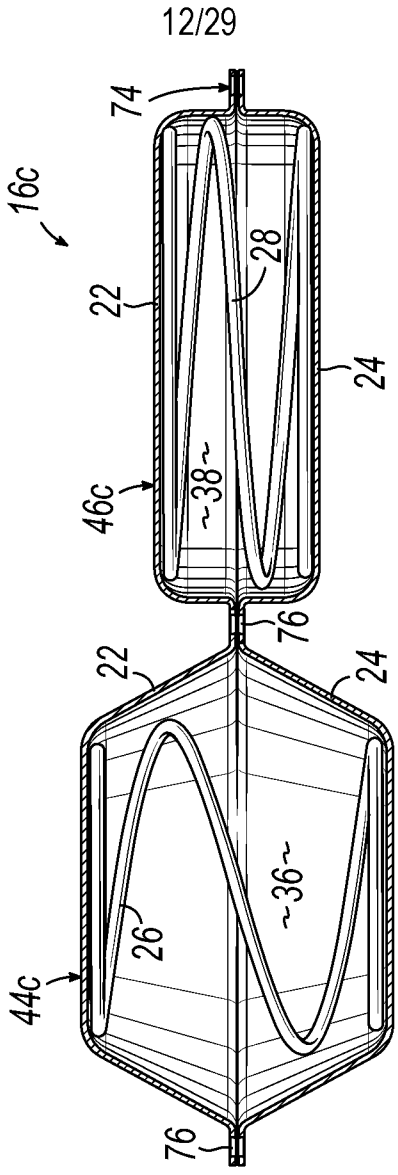
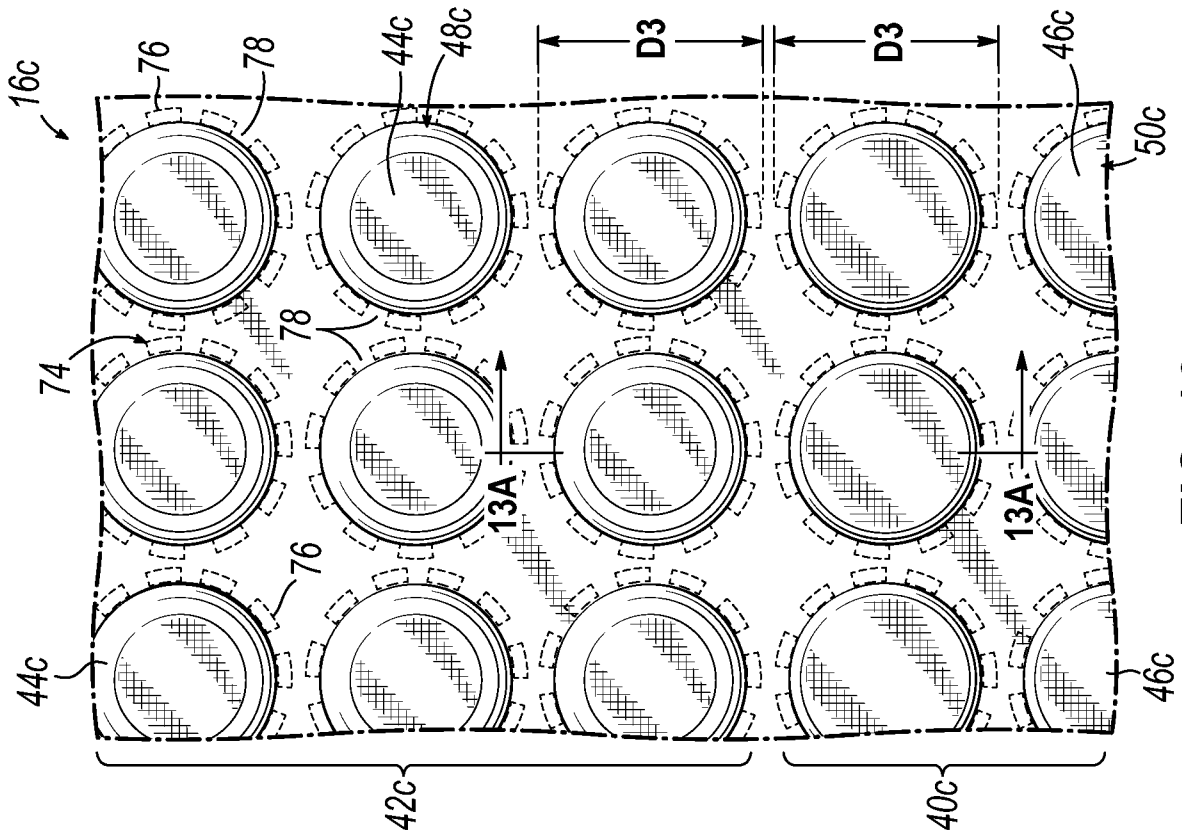

FIG. 13A

FIG. 13

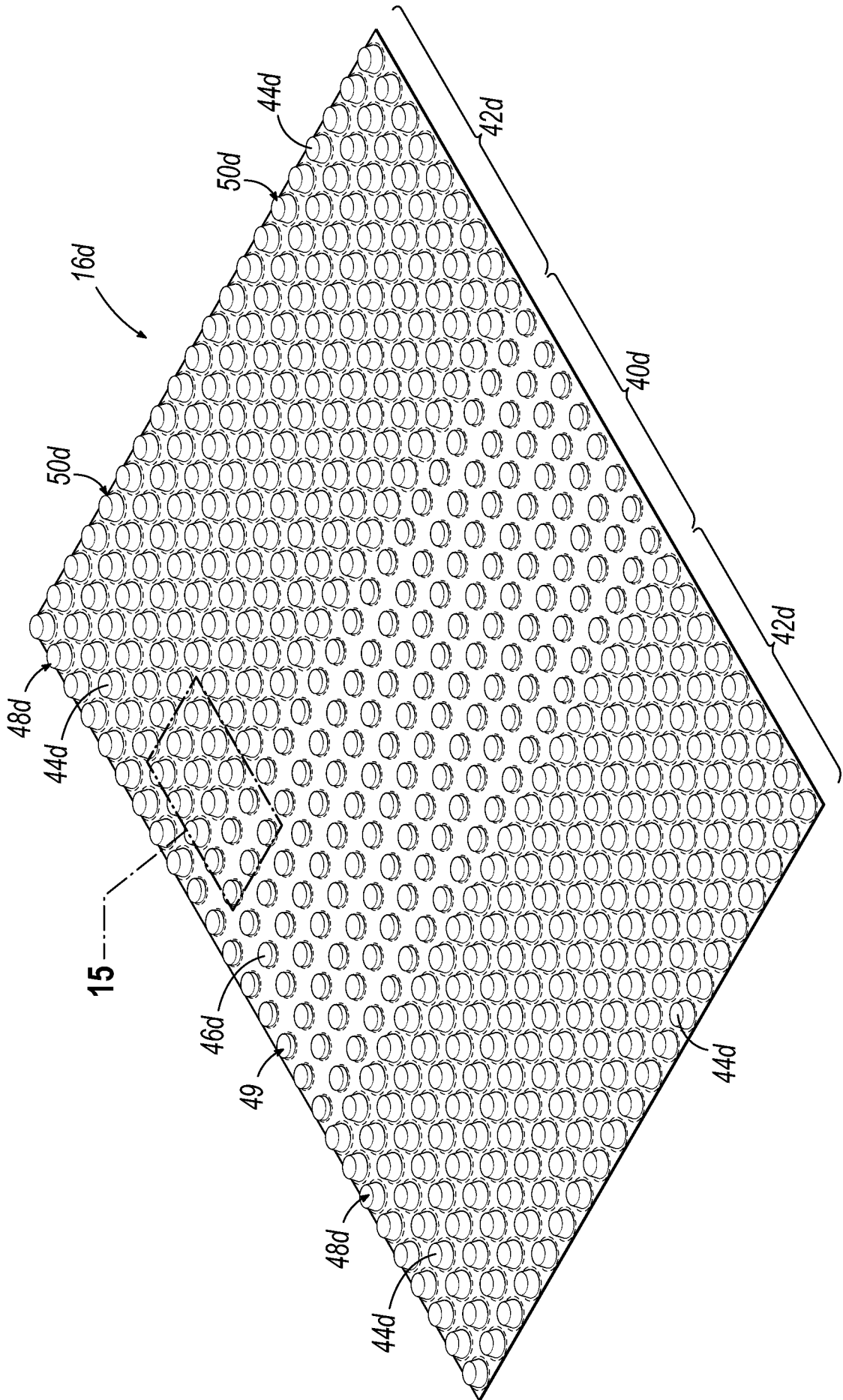

FIG. 14



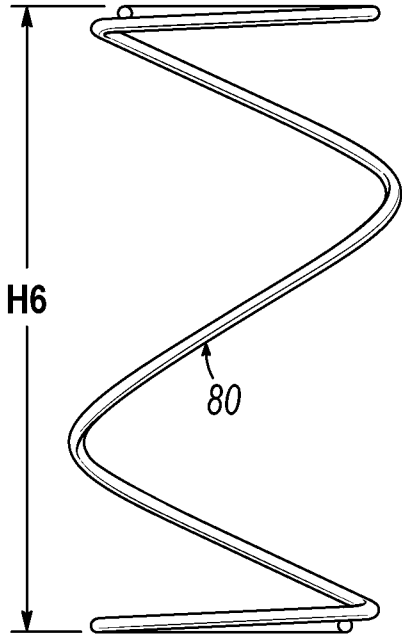

FIG. 16A

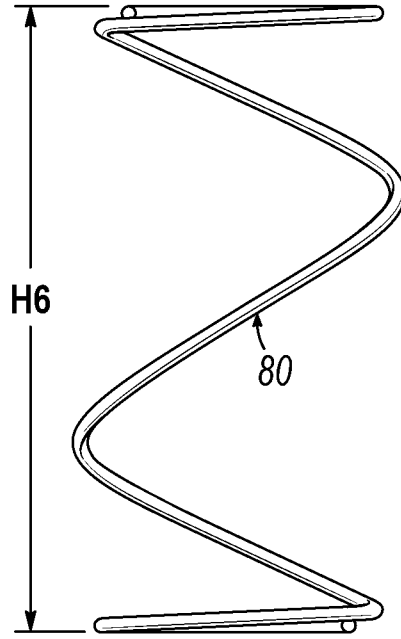

FIG. 17A

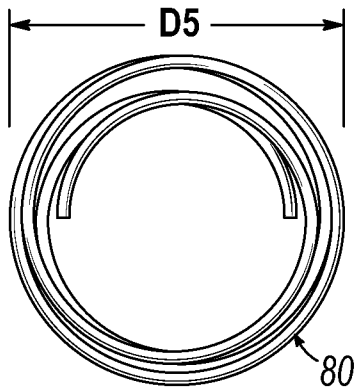

FIG. 16B

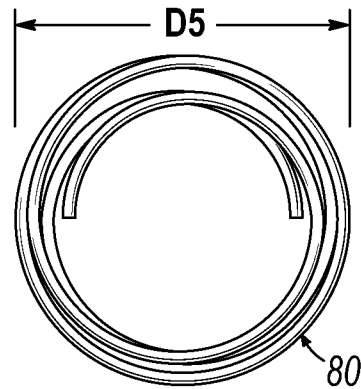

FIG. 17B

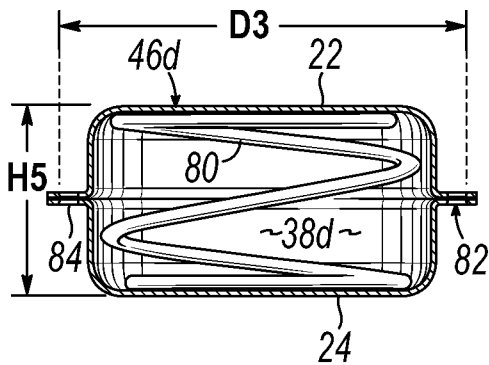

FIG. 16C

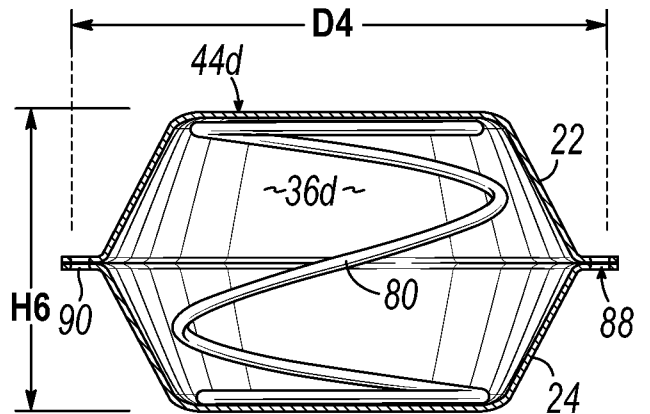

FIG. 17C

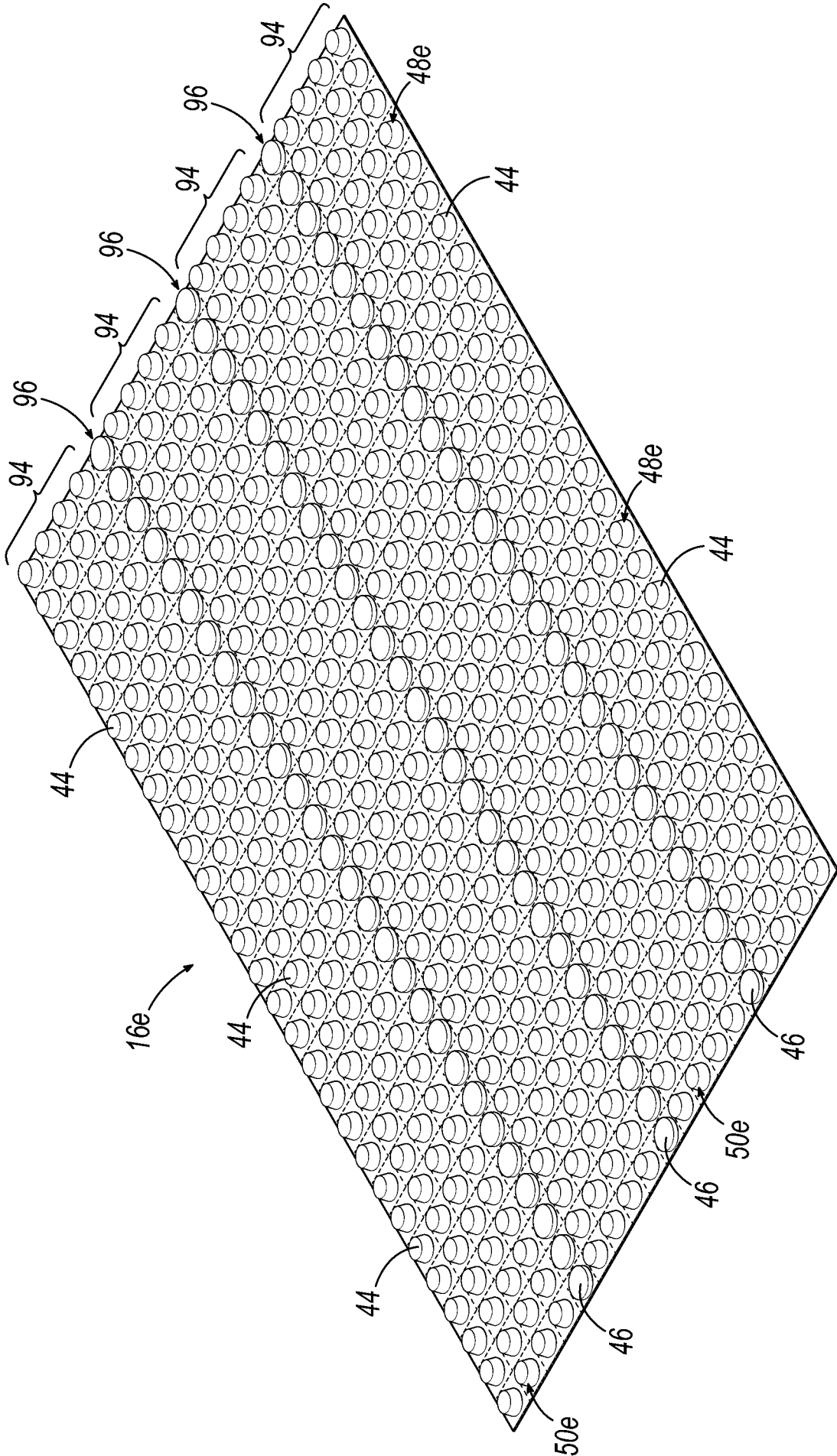

FIG. 18A

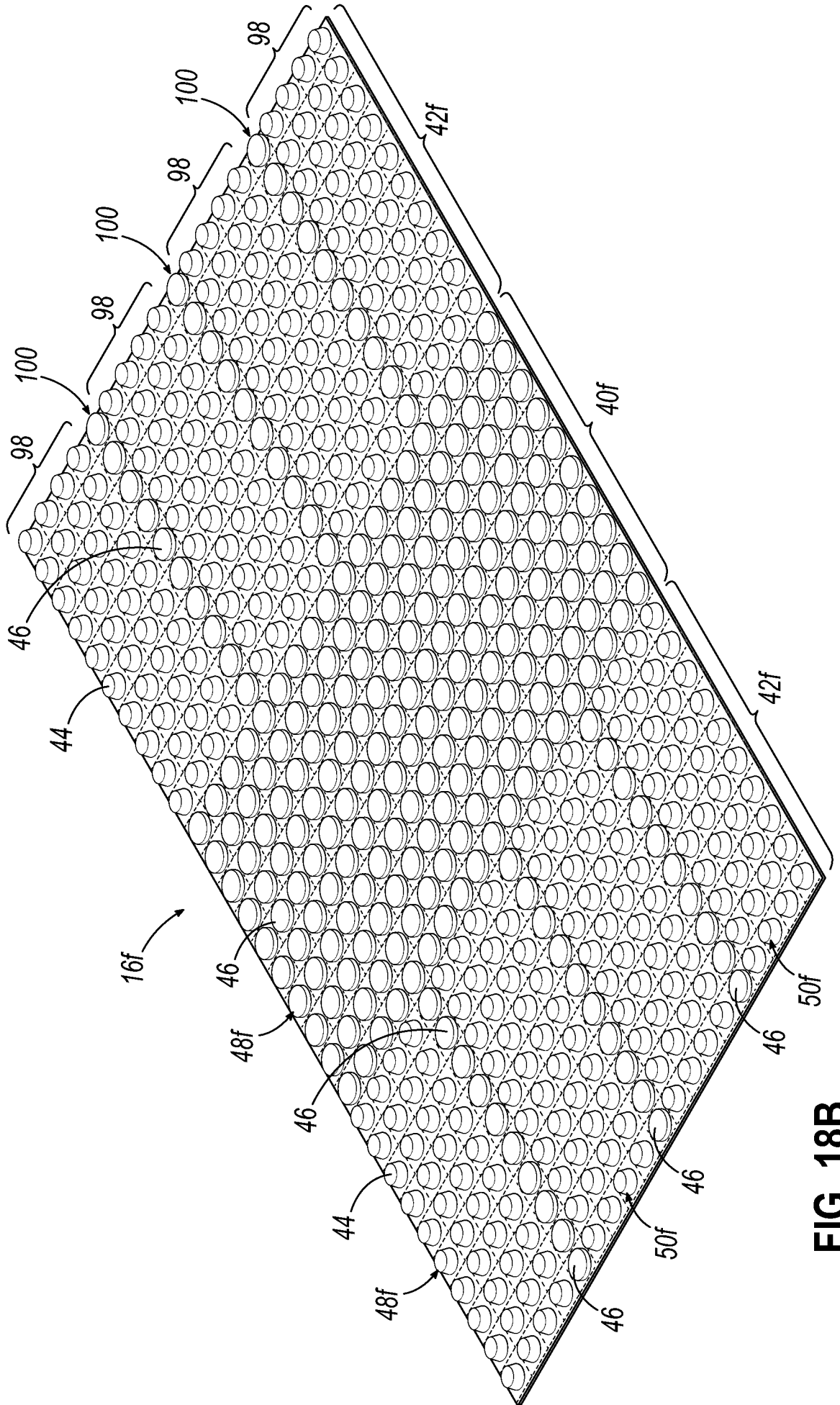

FIG. 18B

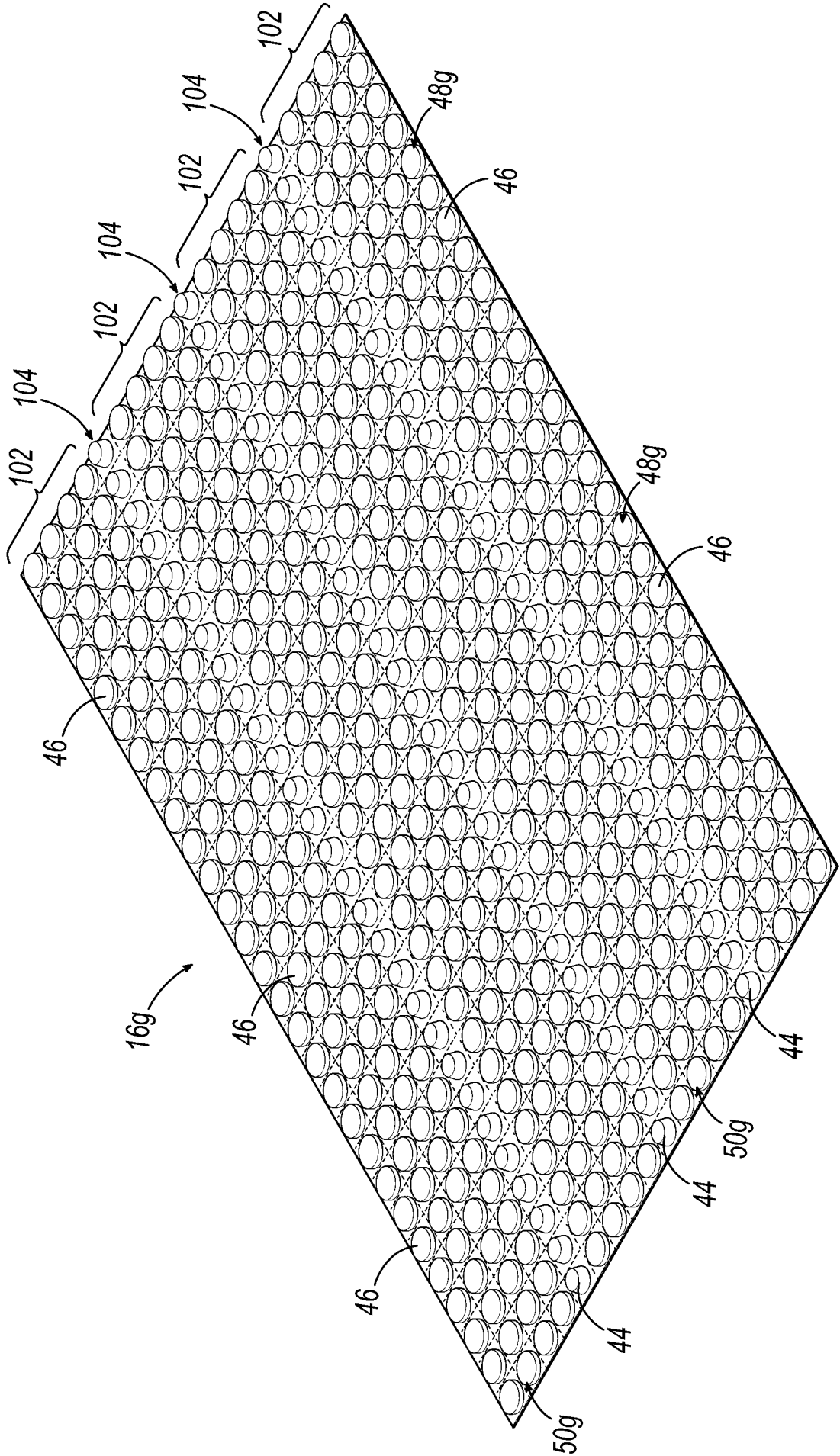

FIG. 18C

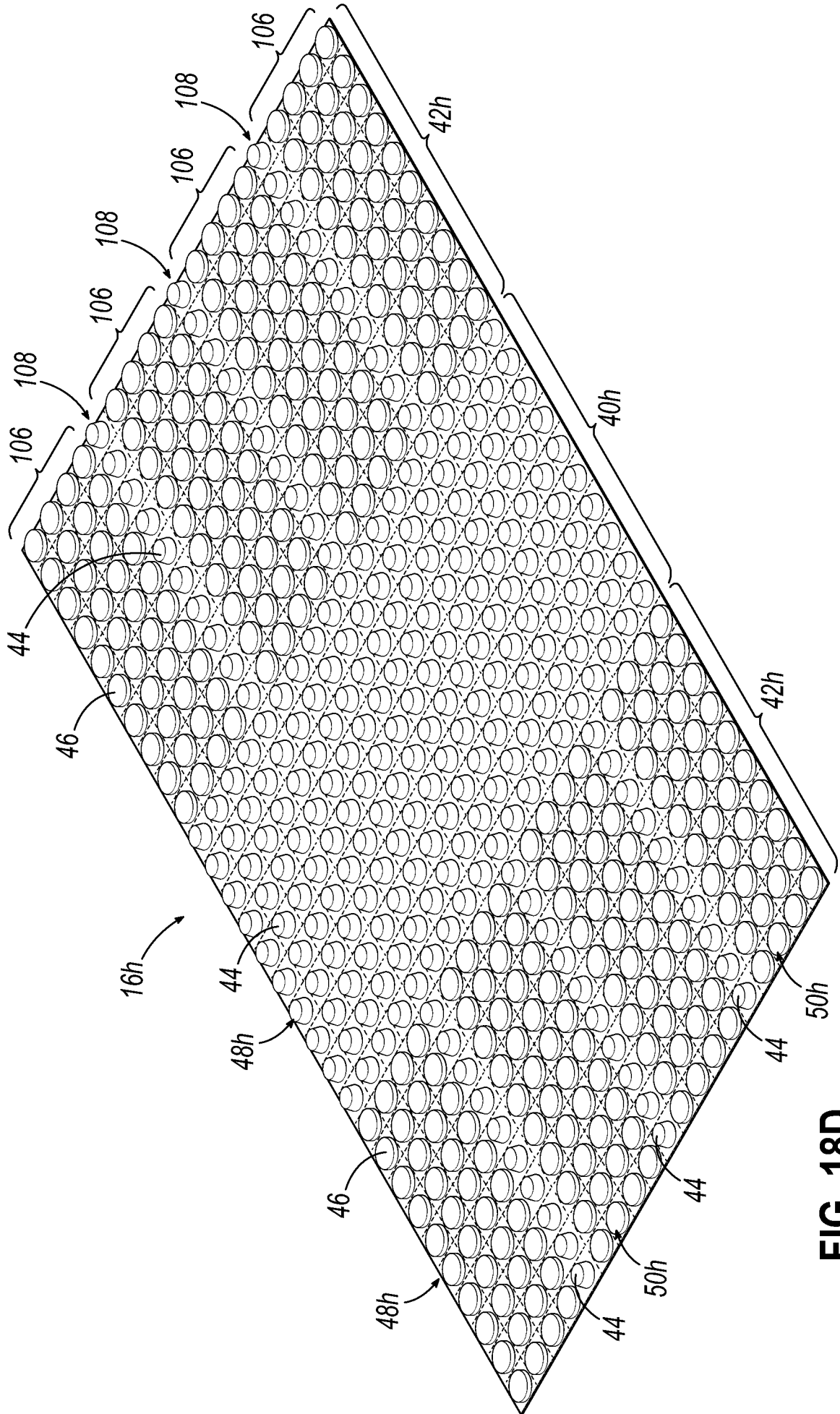

FIG. 18D



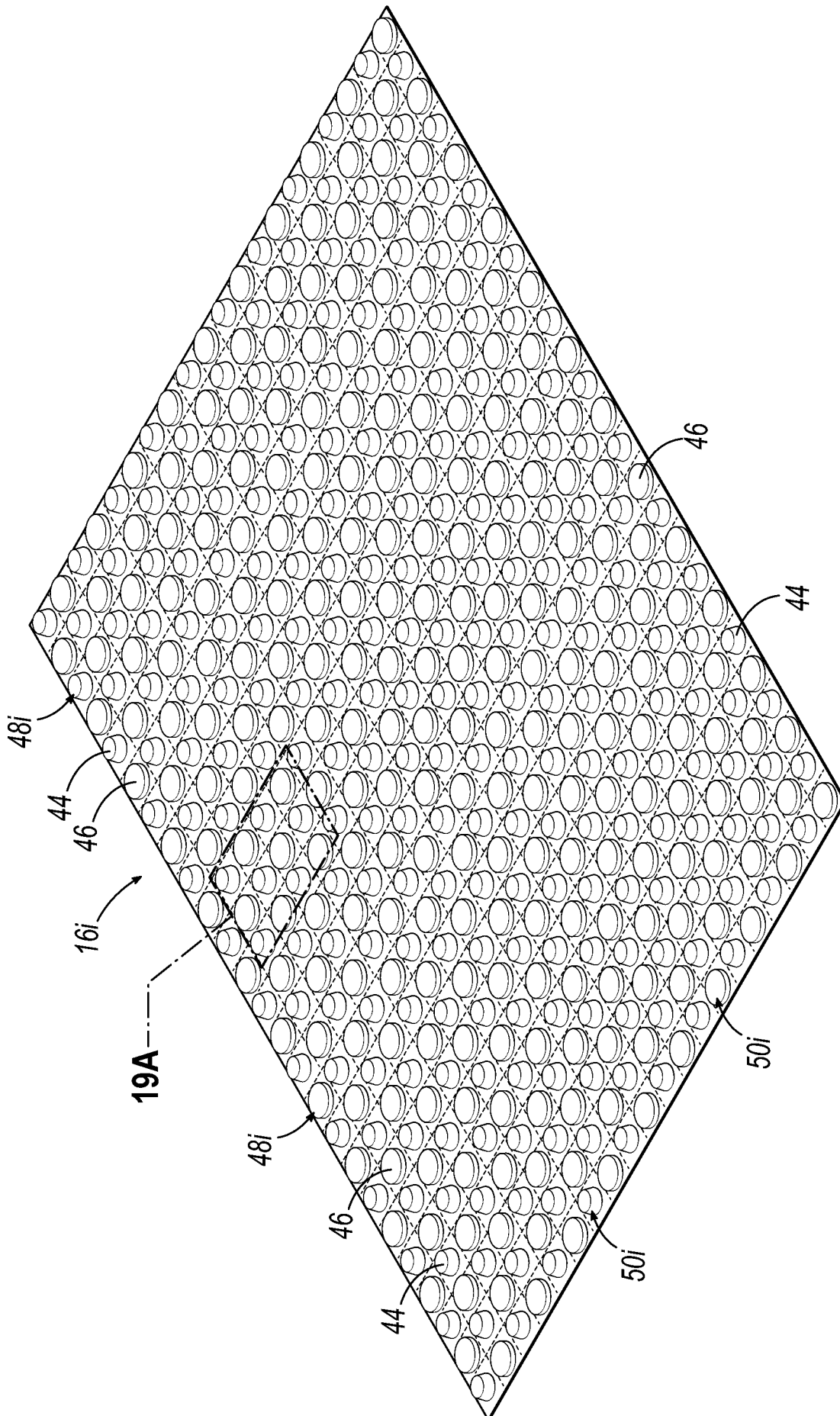

FIG. 19

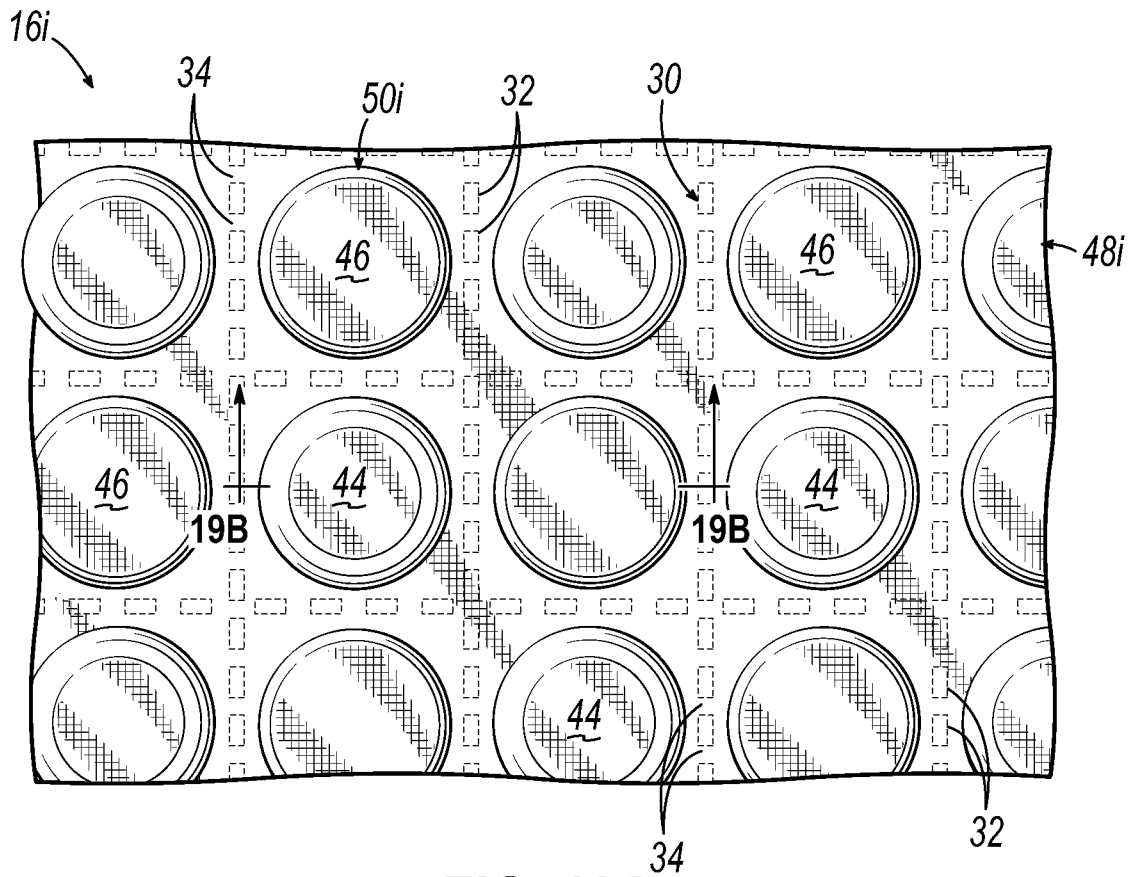

FIG. 19A

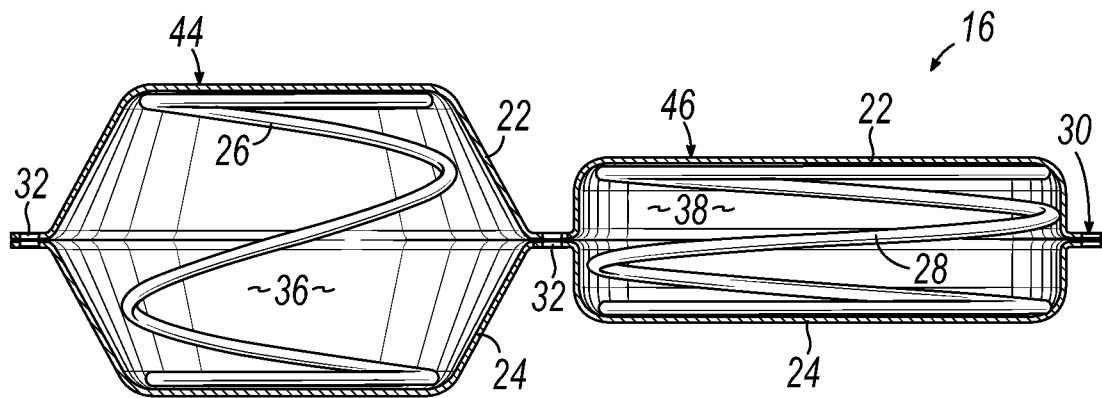

FIG. 19B



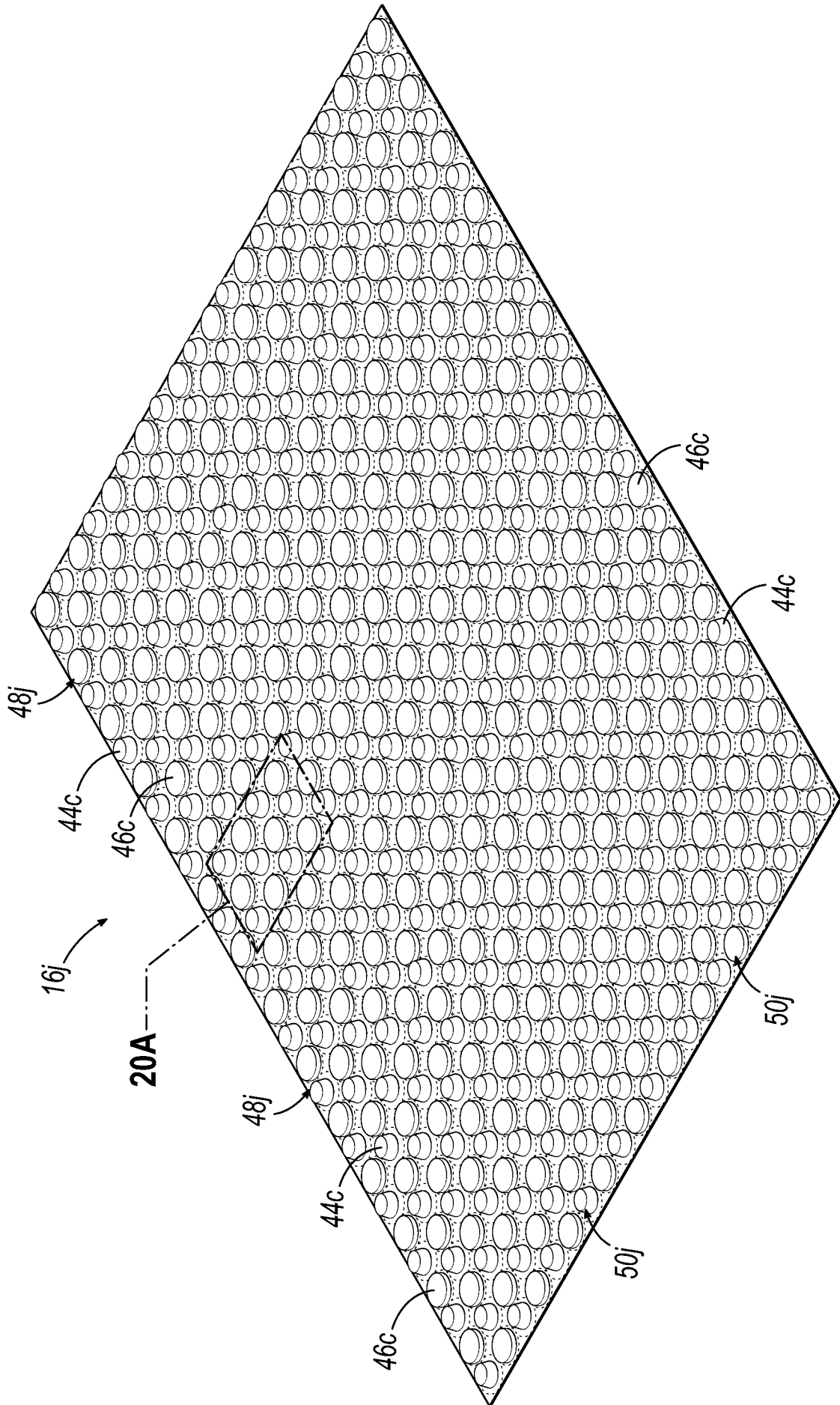

FIG. 20

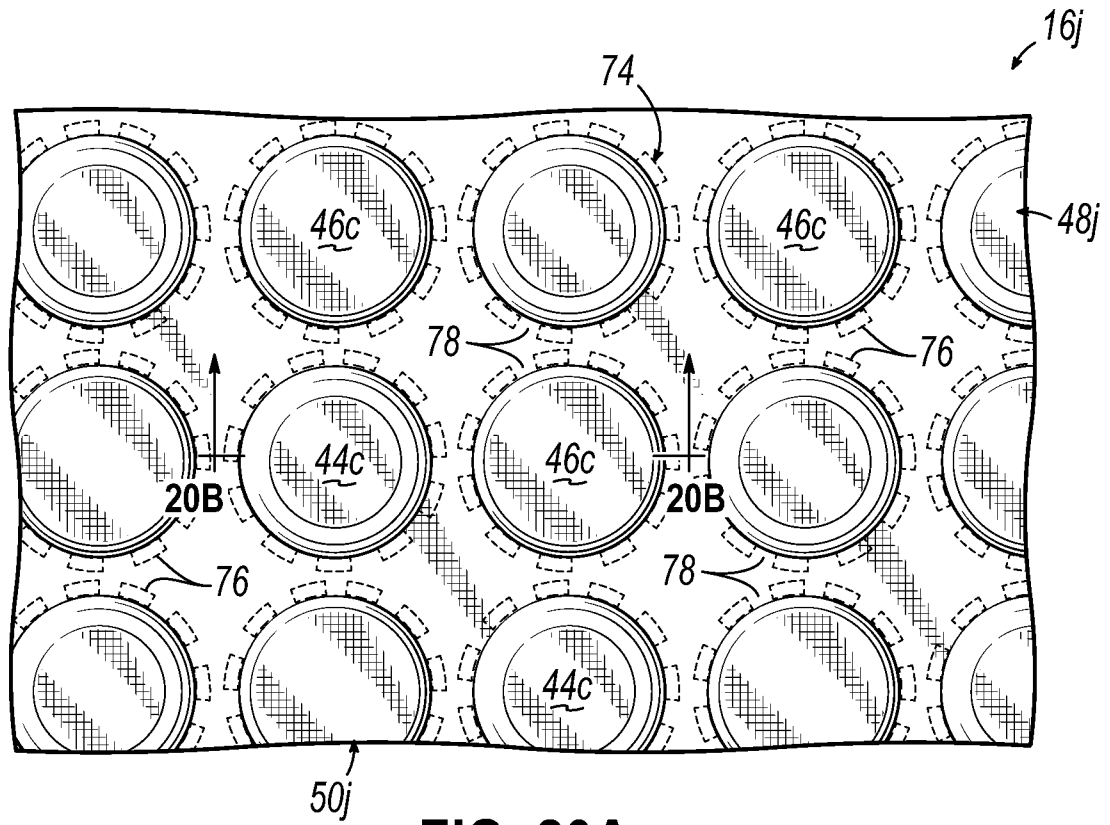

FIG. 20A

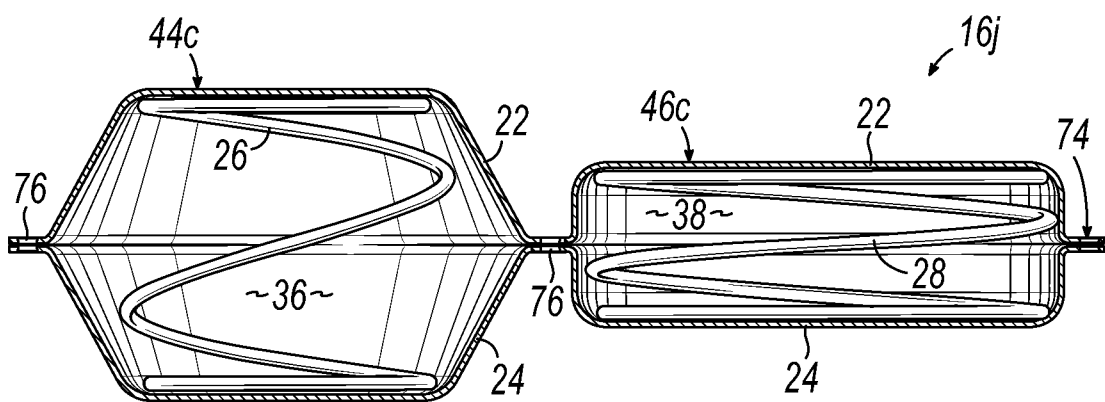

FIG. 20B

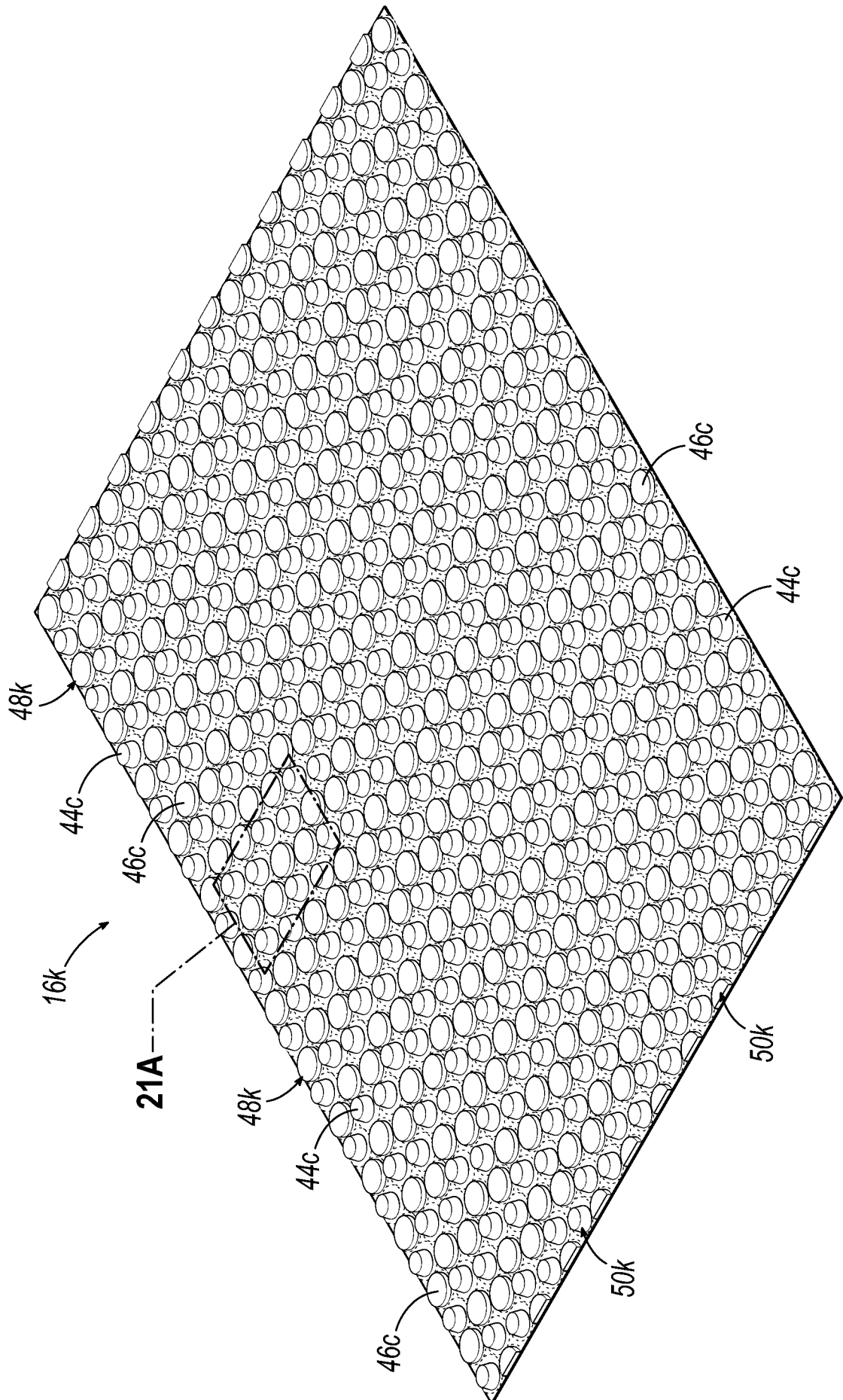

FIG. 21

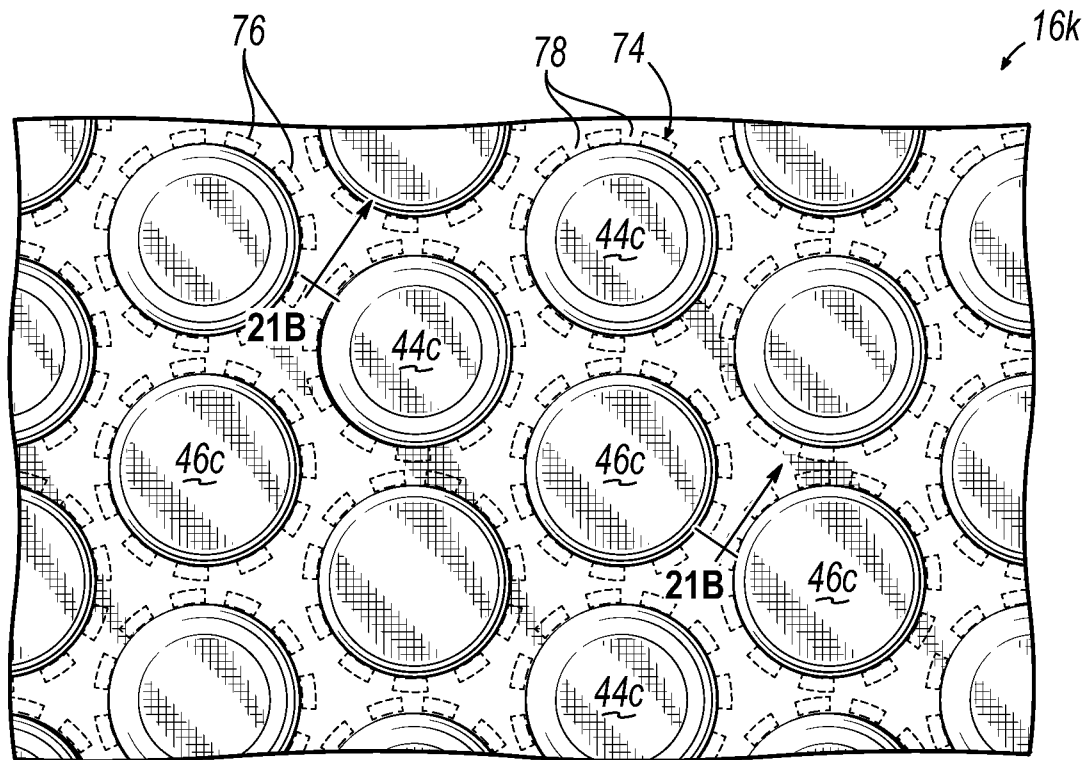

FIG. 21A

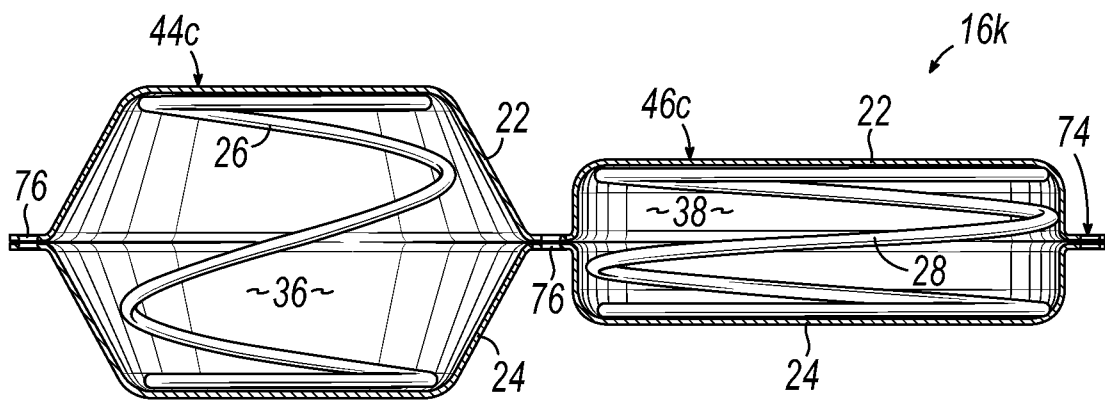

FIG. 21B

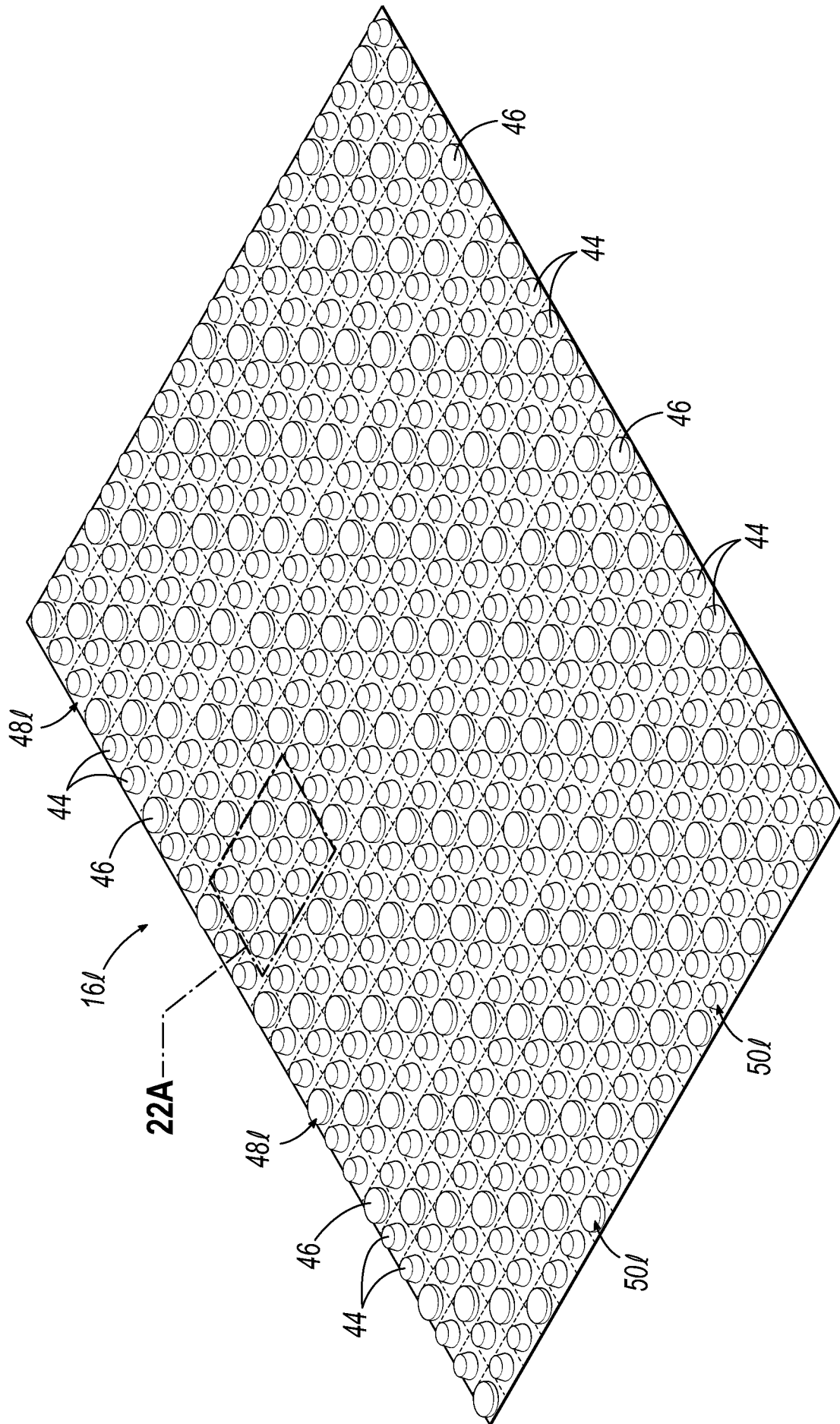

FIG. 22

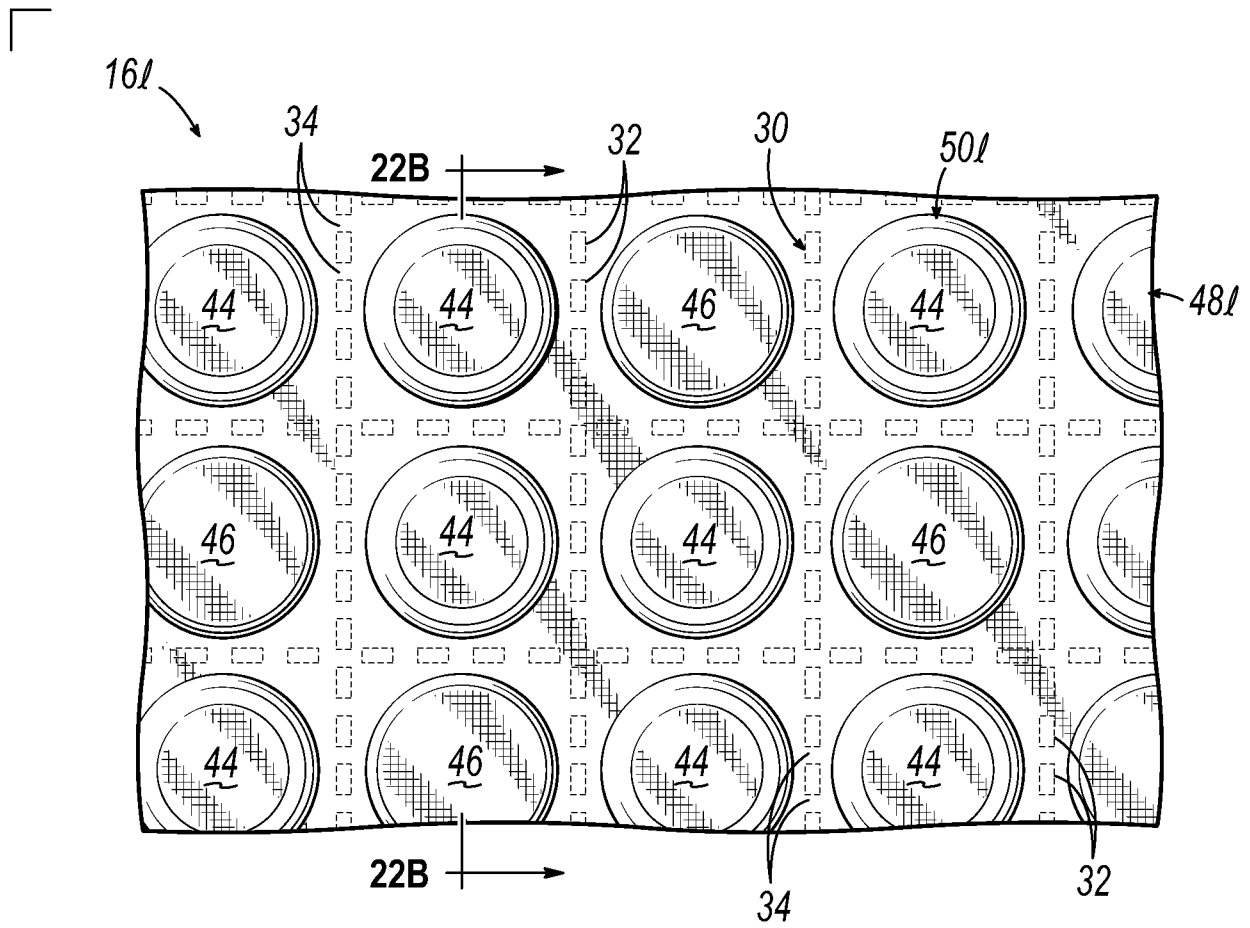

FIG. 22A

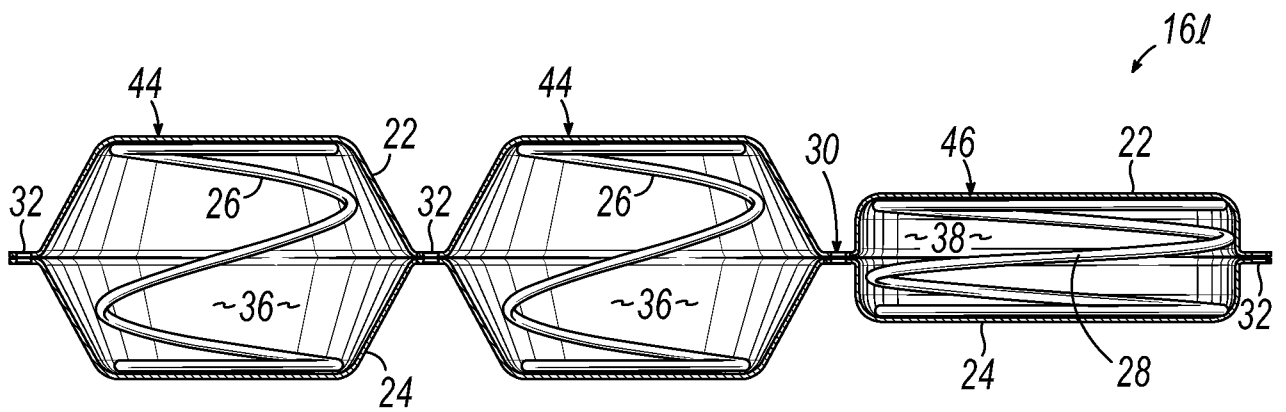

FIG. 22B

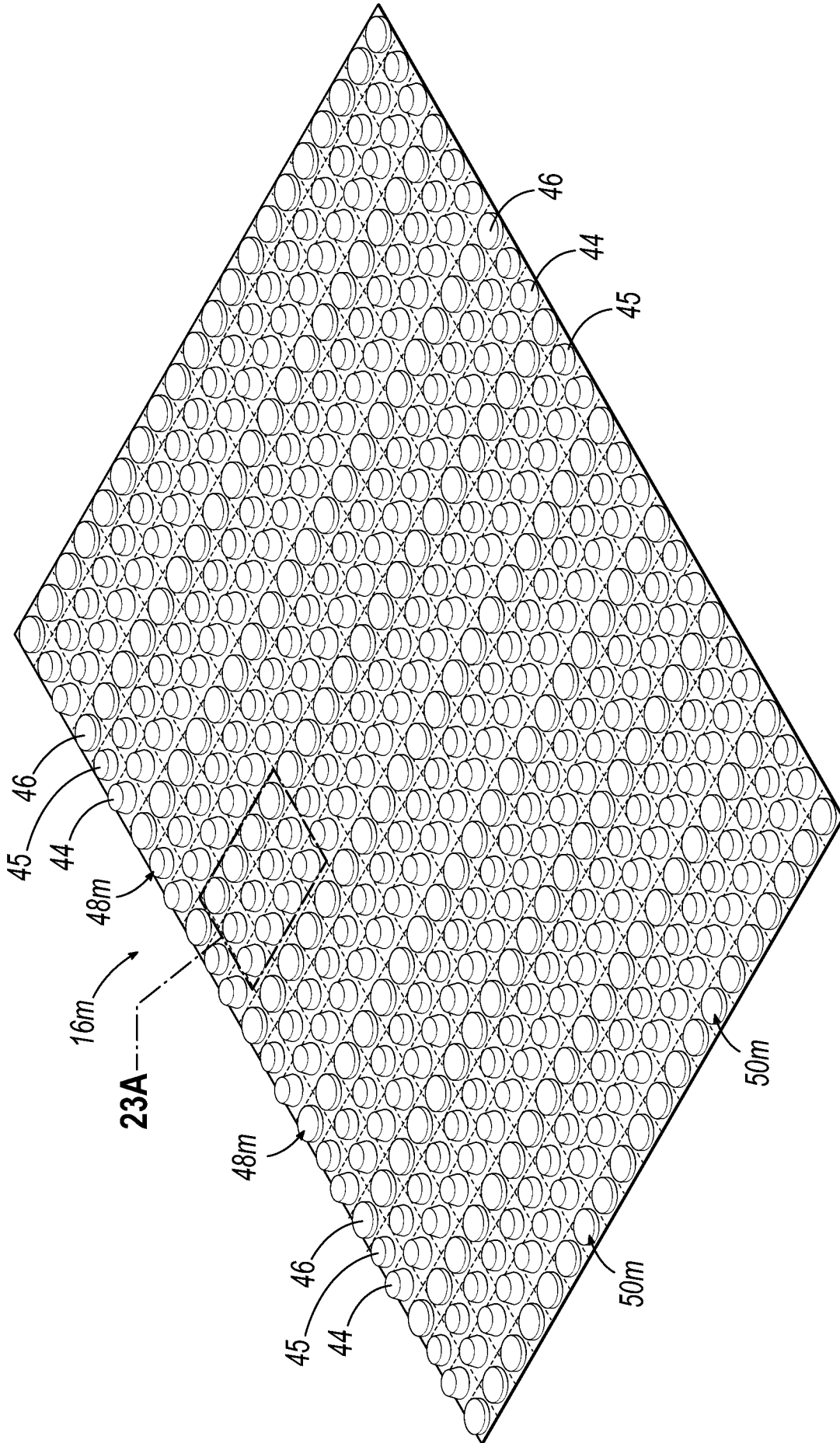

FIG. 23

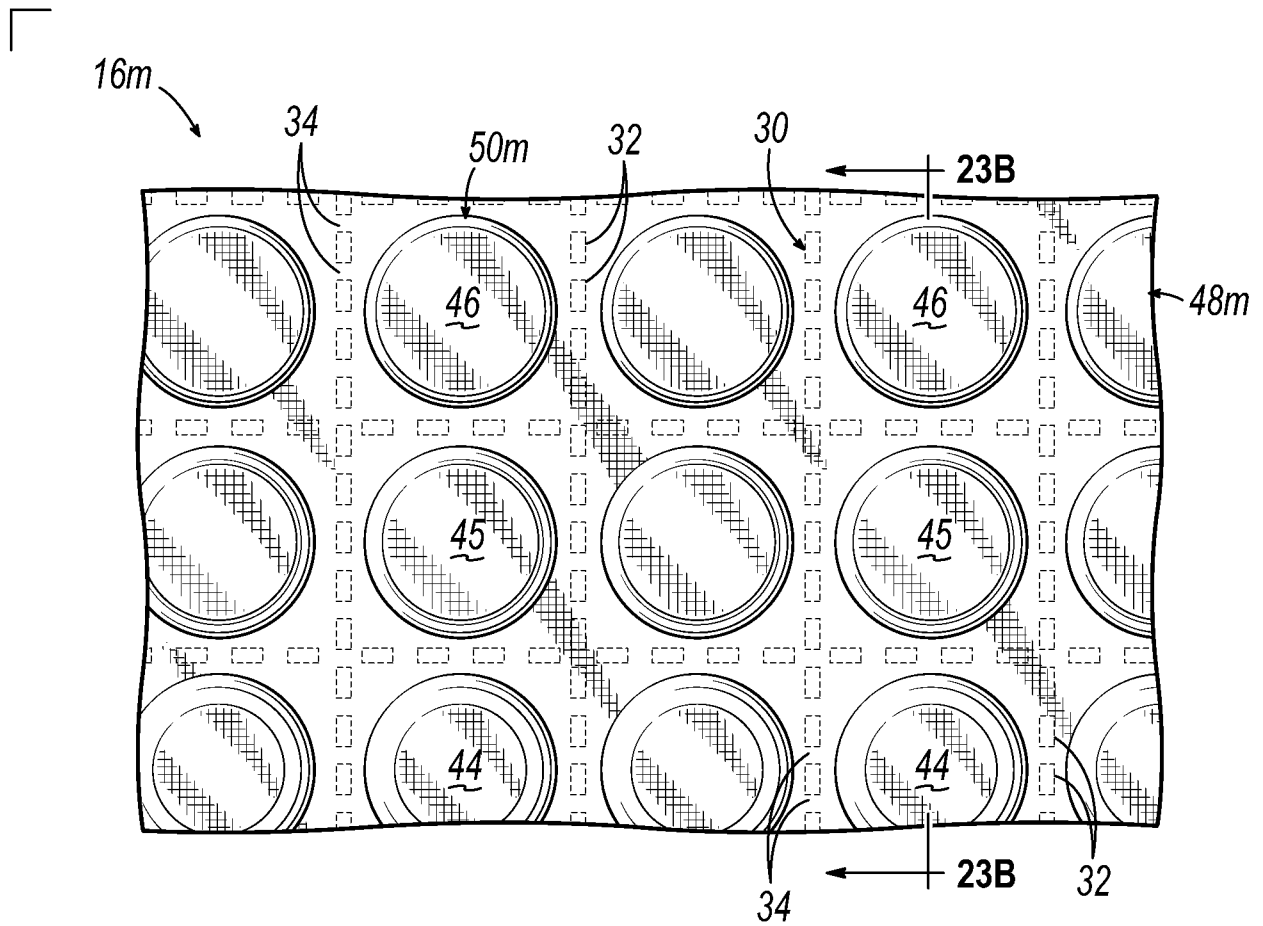

FIG. 23A

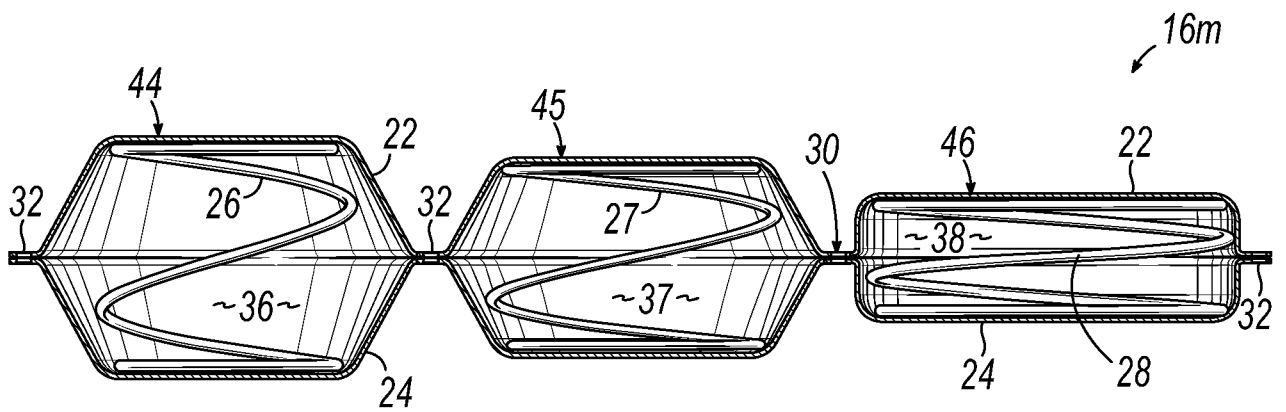

FIG. 23B

## INTERNATIONAL SEARCH REPORT

International application No.

PCT/US20/13781

## A. CLASSIFICATION OF SUBJECT MATTER

IPC - A47C 7/00, 7/34, 27/00, 27/06, 27/07; B68G 9/00 (2020.01)

CPC - A47C 7/00, 7/34, 7/347, 7/35, 27/00, 27/062, 27/064, 27/07; B68G 9/00

According to International Patent Classification (IPC) or to both national classification and IPC

## B. FIELDS SEARCHED

Minimum documentation searched (classification system followed by classification symbols)

See Search History document

Documentation searched other than minimum documentation to the extent that such documents are included in the fields searched

See Search History document

Electronic data base consulted during the international search (name of data base and, where practicable, search terms used)

See Search History document

## C. DOCUMENTS CONSIDERED TO BE RELEVANT

Category*	Citation of document, with indication, where appropriate, of the relevant passages	Relevant to claim No.
Y	US 2016/0235212 A1 (L&P PROPERTY MANAGEMENT) 18 August 2016; Figure 1; Paragraph [0016]	1-5, 7-11, 13-20
Y	US 2005/0257323 A1 (EDLING, K et al.) 24 November 2005; Figure 1; Paragraph [0048]	1-5, 11, 15-20
Y	WO 2003/096847 A1 (SPRINGFORM TECHNOLOGY LIMITED) 27 November 2003; Figure 7	7-11, 13-14
---		---
A		6, 12
A	WO 2018/224139 A1 (SPUHL GMBH) 07 June 2017; Entire Document	6, 12
A	CN 206792145U (ZHEJIANG ANJI DKX HOUSEHOLD CO LTD) 26 December 2017; Entire Document; [MACHINE TRANSLATED]	6, 12
P,A	US 2019/0269251 A1 (L&P Property Management Company) 5 September 2019; Entire Document	1-20

 Further documents are listed in the continuation of Box C. See patent family annex.

\* Special categories of cited documents:

"A" document defining the general state of the art which is not considered to be of particular relevance

"D" document cited by the applicant in the international application

"E" earlier application or patent but published on or after the international filing date

"L" document which may throw doubts on priority claim(s) or which is cited to establish the publication date of another citation or other special reason (as specified)

"O" document referring to an oral disclosure, use, exhibition or other means

"P" document published prior to the international filing date but later than the priority date claimed

"T" later document published after the international filing date or priority date and not in conflict with the application but cited to understand the principle or theory underlying the invention

"X" document of particular relevance; the claimed invention cannot be considered novel or cannot be considered to involve an inventive step when the document is taken alone

"Y" document of particular relevance; the claimed invention cannot be considered to involve an inventive step when the document is combined with one or more other such documents, such combination being obvious to a person skilled in the art

"&amp;" document member of the same patent family

Date of the actual completion of the international search

11 March 2020 (11.03.2020)

Date of mailing of the international search report

21 APR 2020

Name and mailing address of the ISA/US

Mail Stop PCT, Attn: ISA/US, Commissioner for Patents  
P.O. Box 1450, Alexandria, Virginia 22313-1450

Facsimile No. 571-273-8300

Authorized officer

Shane Thomas

Telephone No. PCT Helpdesk: 571-272-4300