

(12) STANDARD PATENT
(19) AUSTRALIAN PATENT OFFICE

(11) Application No. **AU 2016252113 B2**

(54) Title
Lightweight, high flow hose assembly and method of manufacture

(51) International Patent Classification(s)
F16L 11/20 (2006.01)

(21) Application No: **2016252113** (22) Date of Filing: **2016.04.18**

(87) WIPO No: **WO16/172019**

(30) Priority Data

(31) Number	(32) Date	(33) Country
14/695,912	2015.04.24	US
15/085,031	2016.03.30	US
15/084,961	2016.03.30	US
14/850,225	2015.09.10	US
14/730,852	2015.06.04	US

(43) Publication Date: **2016.10.27**

(44) Accepted Journal Date: **2018.11.08**

(71) Applicant(s)
Teknor Apex Company

(72) Inventor(s)
Blanchette, Gil; Melo, Michael; Correa, Steve; Chapman, Timothy L.; Van Beek, Marlon; Parker, John W.; Burke, Paul; Eilertson, Ron

(74) Agent / Attorney
Spruson & Ferguson, GPO Box 3898, Sydney, NSW, 2001, AU

(56) Related Art
US 8757213 B2
US 7887662 B2
US 20100212768 A1



(51) International Patent Classification:
F16L 11/20 (2006.01)

(21) International Application Number:
PCT/US2016/028037

(22) International Filing Date:
18 April 2016 (18.04.2016)

(25) Filing Language: English

(26) Publication Language: English

(30) Priority Data:
14/695,912 24 April 2015 (24.04.2015) US
14/730,852 4 June 2015 (04.06.2015) US
14/850,225 10 September 2015 (10.09.2015) US
15/084,961 30 March 2016 (30.03.2016) US
15/085,031 30 March 2016 (30.03.2016) US

(71) Applicant: **TEKNOR APEX COMPANY** [US/US]; 505 Central Avenue, Pawtucket, Rhode Island 02861-1900 (US).

(72) Inventors: **BLANCHETTE, Gil**; 137 Lakedell Drive, E. Greenwich, Rhode Island 02818 (US). **MELO, Michael**; 1299 Sturgis Drive, North Dartmouth, Massachusetts 02747 (US). **CORREA, Steve**; 1140 Chestnut Grove Rd., Brownsville, Tennessee 38012 (US). **CHAPMAN, Timothy L.**; 211 Carney Road, Stanton, Tennessee 38069 (US). **VAN BEEK, Marlon**; 917 Brentwood Way, Simpsonville, South Carolina 29680 (US). **PARKER, John W.**; 4885 Briarcliff Avenue, Memphis, Tennessee 38117 (US). **BURKE, Paul**; 9 Pomfret Lane, Essex, Ver-

mont 05452 (US). **EILERTSON, Ron**; 31 Riverwood Drive, Mansfield, Massachusetts 02062 (US).

(74) Agents: **HUDAK, Daniel J., Jr.** et al.; Hudak, Shunk & Farine Co. LPA, 2020 Front St., Suite 307, Cuyahoga Falls, Ohio 44221 (US).

(81) Designated States (unless otherwise indicated, for every kind of national protection available): AE, AG, AL, AM, AO, AT, AU, AZ, BA, BB, BG, BH, BN, BR, BW, BY, BZ, CA, CH, CL, CN, CO, CR, CU, CZ, DE, DK, DM, DO, DZ, EC, EE, EG, ES, FI, GB, GD, GE, GH, GM, GT, HN, HR, HU, ID, IL, IN, IR, IS, JP, KE, KG, KN, KP, KR, KZ, LA, LC, LK, LR, LS, LU, LY, MA, MD, ME, MG, MK, MN, MW, MX, MY, MZ, NA, NG, NI, NO, NZ, OM, PA, PE, PG, PH, PL, PT, QA, RO, RS, RU, RW, SA, SC, SD, SE, SG, SK, SL, SM, ST, SV, SY, TH, TJ, TM, TN, TR, TT, TZ, UA, UG, US, UZ, VC, VN, ZA, ZM, ZW.

(84) Designated States (unless otherwise indicated, for every kind of regional protection available): ARIPO (BW, GH, GM, KE, LR, LS, MW, MZ, NA, RW, SD, SL, ST, SZ, TZ, UG, ZM, ZW), Eurasian (AM, AZ, BY, KG, KZ, RU, TJ, TM), European (AL, AT, BE, BG, CH, CY, CZ, DE, DK, EE, ES, FI, FR, GB, GR, HR, HU, IE, IS, IT, LT, LU, LV, MC, MK, MT, NL, NO, PL, PT, RO, RS, SE, SI, SK, SM, TR), OAPI (BF, BJ, CF, CG, CI, CM, GA, GN, GQ, GW, KM, ML, MR, NE, SN, TD, TG).

Published:

— with international search report (Art. 21(3))

(54) Title: LIGHTWEIGHT, HIGH FLOW HOSE ASSEMBLY AND METHOD OF MANUFACTURE

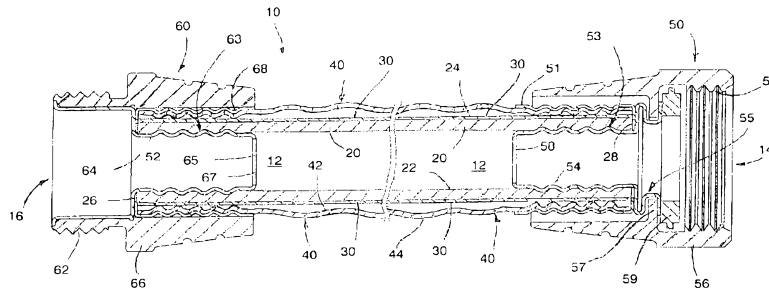

FIG. 1

(57) Abstract: A hose assembly, preferably a garden hose assembly, including a jacketed tube that is lightweight, durable and versatile. The tube is able to expand longitudinally along the length-wise axis of the hose between hose ends, as well as radially or circumferentially, to an expanded state in response to application of at least a minimum fluid pressure to an inner tube of the hose. Once the fluid pressure falls below the minimum fluid pressure, the hose assembly will contract. The two layer construction of the hose assembly allows for storage in relatively compact spaces, similar flow rates, approximately one-half the weight, and improved maneuverability when compared to conventional hose constructions. In one embodiment the jacket is formed around the tube in a continuous process that welds a material, preferably using hot air, into the jacket.

WO 2016/172019 A1

LIGHTWEIGHT, HIGH FLOW HOSE ASSEMBLY AND METHOD OF MANUFACTURE

FIELD OF THE INVENTION

[0001] The present invention relates to a hose assembly, preferably a garden hose assembly, including a fabric and/or non-fabric jacketed tube, that is lightweight, durable and versatile. The tube is able to expand longitudinally along the length-wise axis of the hose between hose ends, and/or radially or circumferentially, to an expanded state in response to application of at least a minimum fluid pressure to an inner tube of the hose. Once the fluid pressure falls below the minimum fluid pressure, the hose assembly will contract. The two layer construction of the hose assembly allows for storage in relatively compact spaces, similar flow rates, approximately one-half the weight, and improved maneuverability when compared to conventional hose constructions. In one embodiment, the jacket is formed around the tube in a continuous process that welds a fabric and/or non-fabric, preferably using hot air, into the jacket. The welded joint forms a region of jacket that is preferably about twice the thickness of the rest of the jacket. This thicker region results in a stiffer section of jacket that makes the hose more controllable and consistent in use.

BACKGROUND OF THE INVENTION

[0002] Numerous different types or styles of garden hoses are known in the art and commercially available.

[0003] For example, traditionally conventional hoses are polymeric and can be reinforced, have a substantially fixed longitudinal length, and have relatively low radial expansion upon internal application of fluid pressure. Due to their construction, some conventional hoses can be relatively heavy and cumbersome to use and store.

[0004] More recently, garden hoses longitudinally expandable along their length multiple times as compared to the length of the hose in an unpressurized or contracted state have been introduced. In some embodiments such hoses have a construction that includes a jacket that surrounds an expandable fluid conveying tube. Longitudinally and radially expandable hoses are popular for a variety of reasons

including, but not limited to, lightweight construction and ease of storage when not in use.

[0005] Longitudinally expandable hoses are commercially available from a number of sources. The hoses are also described in various patents and publications, see for example: U.S. Patent Nos. 6,948,527; 7,549,448; 8,371,143; 8,776,836; 8,291,942; 8,479,776; 8,757,213; as well as U.S. Patent Application Publication Nos. 2014/0150889; and 2014/0130930.

[0006] A problem with some of the length expandable hoses is that they can kink, bulge, fail and/or exhibit leakage, at one or more points along their length, for example at a connection point to a coupler or fitting at the end of the hose, after a number of expansion and contraction cycles.

SUMMARY OF THE INVENTION

[0007] The problems described above and others are solved by the hose assemblies of the present invention which are relatively lightweight, as compared to the traditionally conventional hoses, durable, and versatile. In some embodiments, the hose assemblies provide a flow rate similar to a conventional garden hose at approximately one-half the weight. The hose assemblies also provide improved maneuverability due to their light weight, kink resistance in view of the non-bonded, two-layer jacket construction and ease of storage over a conventional hose.

[0008] According to one embodiment or objective of the present invention, a hose assembly is disclosed comprising a lightweight elastomeric or thermoplastic inner tube surrounded by a fabric-like or non-fabric outer tube that serves as a jacket for the inner tube. This jacket also prevents the length of the product from changing at different pressure conditions. The length of the product is fixed by the length of the outer jacket. The inner tube can expand longitudinally along the length-wise axis of the hose between hose ends or couplers, as well as along a radial axis of the tube when pressure at or above a minimum fluid pressure is applied to the inner tube. When the pressure falls below the minimum fluid pressure, the inner tube of the hose assembly will contract both longitudinally and radially. The longitudinal and radial rates of contraction depend on the composition of the inner tube. The outer tube limits the longitudinal and radial expansion of the inner tube in one embodiment.

[0009] Still another embodiment or objective of the present invention is to provide a hose assembly including a fabric outer tube or non-fabric outer tube that is welded around the inner tube and includes a weld seam extending along a longitudinal axis of the hose assembly. The weld seam has a greater thickness, i.e. wall thickness, as compared to a wall thickness of the unwelded fabric or non-fabric outer tube.

[0010] Yet another embodiment or objective of the present invention is to provide a method for producing a hose assembly comprising a hot air welding or seaming process whereby the outer tube is formed via welding, preferably hot air welding, around the inner tube, preferably utilizing a continuous process. It is possible for the circumferential size of the outer tube to be varied in order to produce hose assemblies having different maximum internal diameters of the inner tube.

[0011] An additional embodiment or objective of the present invention is to provide a method for producing a hose assembly comprising the steps of obtaining a polymeric or synthetic fabric or non-fabric material or a combination thereof, heating lateral sides of the material at or above a melting temperature thereof and bonding the lateral sides together around an inner tube in order to form a weld. As the fabric or non-fabric material or a combination thereof is bonded along the length of the inner tube, the outer tube is formed having a weld seam along the longitudinal length of the hose assembly. Advantageously, the process for preparing the hose assembly of the present invention i) allows manufacture of an outer tube having a weld that can be stronger than the original material, ii) has relatively low labor costs and iii) also produces a construction having the inner tube inserted into the outer tube as part of the welding process.

[0012] Still another embodiment or objective of the present invention is to provide the hose assembly with a desirable burst strength such that failure of one or more of the inner tube and outer tube is avoided at working pressures. In various embodiments, the inner tube and outer tube have a burst strength that ranges between 1,379 kPa (about 200 psi) and 8,274 kPa (about 1200 psi) or about 10,342 kPa (about 1500 psi) measured according to the burst strength test described in ASTM D380-94(2012). Desirable burst strength can be obtained for hose assemblies having inner and outer tubes having a total weight between 74.4 g/m (about 2.5 lbs. per 50 feet of tube

length) and 163.68 g/m (about 5.5 lbs. per 50 feet of tube length). An additional embodiment or objective of the present invention is to provide a hose assembly capable of resisting water pressures in the 400 psi range (pounds per square inch) 2758 kPa. Even though the hose is of a robust construction, the assembly is relatively light in weight, for example about 4 lbs per 50 feet (0.12 kg per meter) in one preferred embodiment.

[0013] In one aspect, a hose assembly is disclosed, comprising: an inner tube comprising one or more of an elastomeric material and a thermoplastic material, wherein the inner tube has a first longitudinal length and a first circumference below a minimum expansion pressure, wherein the inner tube is expandable to one or more of a) a longer, second longitudinal length and b) a larger, second circumference upon application of fluid pressure on an inner surface of the inner tube at or above the minimum expansion pressure; and an outer tube covering the inner tube, the outer tube having a longitudinal length and a weld seam along the longitudinal length of the outer tube, the weld seam comprising melted outer tube material.

[0014] In another aspect, a process for producing a hose assembly is disclosed, comprising: obtaining an inner tube comprising one or more of an elastomeric material and a thermoplastic material, wherein the inner tube has a first longitudinal length and a first circumference below a minimum expansion pressure, wherein the inner tube is expandable to one or more of a) a longer, second longitudinal length and b) a larger, second circumference upon application of fluid pressure on an inner surface of the inner tube at or above the minimum expansion pressure; obtaining a material having a first end, a second end, a first side and a second side, the sides located between the ends; wrapping the material around the inner tube and abutting the first side and the second side of the material, and heating the material to melt and bond the first side to the second side along a length of the sides thereby forming an outer tube having a weld seam along a longitudinal length of the hose assembly, wherein during formation of the outer tube a section of the inner tube is located inside the outer tube.

[0015] In a further aspect, a fabric-jacketed hose assembly is disclosed, comprising an inner tube comprising a thermoplastic material, wherein the inner tube has a longitudinal length and a first circumference below a minimum expansion pressure,

wherein the inner tube is expandable to a larger, second circumference upon application of fluid pressure on an inner surface of the inner tube at or above the minimum expansion pressure; and an outer tube covering the inner tube, wherein the outer tube is not bonded, connected or attached to the inner tube between end couplers of the hose assembly, wherein the outer tube comprises a fabric material; and wherein the inner tube and outer tube have a total weight between 74.4 g/m and 163.68 g/m, and a burst strength between 1,379 kPa and 10,342 kPa measured according to ASTM D380-94(2012).

[0016] In a further aspect, a fabric-jacketed hose assembly is disclosed, comprising an inner tube comprising one or more of an elastomeric material and a thermoplastic material, wherein the inner tube has a first longitudinal length and a first circumference below a minimum expansion pressure, wherein the inner tube is expandable to one or more of a) a longer, second longitudinal length and b) a larger, second circumference upon application of fluid pressure on an inner surface of the inner tube at or above the minimum expansion pressure; an outer tube covering the inner tube, wherein the outer tube is not bonded, connected or attached to the inner tube between end couplers of the hose assembly, wherein the outer tube comprises a fabric material; and wherein the inner tube and outer tube have a total weight between 74.4 g/m and 163.68 g/m, and a burst strength between 1,379 kPa and 10,342 kPa measured ASTM D380-94(2012).

[0017] In a further aspect, a hose assembly is disclosed, comprising an inner tube comprising one or more of an elastomeric material and a thermoplastic material, wherein the inner tube has a first longitudinal length and a first circumference below a minimum expansion pressure, wherein the inner tube is expandable to one or more of a) a longer, second longitudinal length and b) a larger, second circumference upon application of fluid pressure on an inner surface of the inner tube at or above the minimum expansion pressure; an outer tube covering the inner tube, wherein the outer tube is not bonded, connected or attached to the inner tube between end couplers of the hose assembly; and wherein the inner tube and outer tube have a total weight between 74.4 g/m and 163.68 g/m, and a burst strength between 1,379 kPa and 10,342 kPa measured ASTM D380-94(2012).

[0018] In a further aspect, a fabric-jacketed hose assembly is disclosed, comprising an inner tube comprising a thermoplastic material, wherein the inner tube has a longitudinal length and a first circumference below a minimum expansion pressure, wherein the inner tube is expandable to a larger, second circumference upon application of fluid pressure on an inner surface of the inner tube at or above the minimum expansion pressure; and an outer tube covering the inner tube, wherein the outer tube is not bonded, connected or attached to the inner tube between end couplers of the hose assembly, wherein the outer tube comprises a fabric material, and wherein the inner tube and outer tube collectively have a burst strength per linear mass density between 18.53 kPa•m/g to 100 kPa•m/g, wherein burst strength is measured according to ASTM D380-94(2012).

[0019] In a further aspect, a fabric-jacketed hose assembly is disclosed, comprising an inner tube comprising one or more of an elastomeric material and a thermoplastic material, wherein the inner tube has a first longitudinal length and a first circumference below a minimum expansion pressure, wherein the inner tube is expandable to one or more of a) a longer, second longitudinal length and b) a larger, second circumference upon application of fluid pressure on an inner surface of the inner tube at or above the minimum expansion pressure; an outer tube covering the inner tube, wherein the outer tube is not bonded, connected or attached to the inner tube between end couplers of the hose assembly, wherein the outer tube comprises a fabric material; and wherein the inner tube and outer tube collectively have a burst strength per linear mass density between 18.53 kPa•m/g to 100 kPa•m/g, wherein burst strength is measured according to ASTM D380-94(2012) , and wherein the inner tube and outer tube have a total weight between 74.4 g/m and 163.68 g/m.

[0020] In a further aspect, a hose assembly is disclosed, comprising an inner tube comprising one or more of an elastomeric material and a thermoplastic material, wherein the inner tube has a first longitudinal length and a first circumference below a minimum expansion pressure, wherein the inner tube is expandable to one or more of a) a longer, second longitudinal length and b) a larger, second circumference upon application of fluid pressure on an inner surface of the inner tube at or above the minimum expansion pressure; an outer tube covering the inner tube, wherein the outer

tube is not bonded, connected or attached to the inner tube between end couplers of the hose assembly; and wherein the inner tube and outer tube collectively have a burst strength per linear mass density between 52 kPa•m/g to 100 kPa•m/g, wherein burst strength is measured according to ASTM D380-94(2012).

BRIEF DESCRIPTION OF THE DRAWINGS

[0021] The invention will be better understood and other features and advantages will become apparent by reading the detailed description of the invention, taken together with the drawings, wherein:

[0022] FIG. 1 is a partial, cross-sectional, longitudinal side view of one embodiment of a hose assembly of the present invention in a longitudinally and circumferentially contracted position;

[0023] FIG. 2 is a partial, cross-sectional, longitudinal side view of one embodiment of a hose assembly of the present invention in an expanded position; and

[0024] FIG. 3 is a partial, longitudinal side view of one embodiment of the hose assembly of the present invention particularly illustrating a weld seam of the outer tube produced by a hot air seaming method that encases an inner tube within the outer tube.

DETAILED DESCRIPTION OF THE INVENTION

[0025] In this specification, all numbers disclosed herein designate a set value, individually, in one embodiment, regardless of whether the word “about” or “approximate” or the like is used in connection therewith. In addition, when the term such as “about” or “approximate” is used in conjunction with a value, the numerical range may also vary, for example by 1%, 2%, 5%, or more in various other, independent, embodiments.

[0026] The hose assembly of the present invention includes a fabric and/or non-fabric jacketed inner tube, with the hose assembly being relatively light in weight, durable and versatile. The inner tube can expand circumferentially or radially to an expanded position or state in response to at least a minimum fluid pressure applied internally to the inner tube. In additional embodiments, the inner tube can expand longitudinally along the length-wise axis of the tube in response to at least minimum fluid pressure

applied internally to the inner tube. The circumference of the jacket controls radial expansion of the inner tube. The length of the jacket controls longitudinal expansion of the inner tube. The inner tube circumferentially or radially and longitudinally contracts when fluid pressure inside the tube falls below the minimum fluid pressure to a contracted or non-expanded position or state. Elastomer-containing inner tubes generally contract at faster rates than inner tubes formed from compositions comprising thermoplastic polymers, such as polyvinyl chloride. In one embodiment, the outer tube jacket is formed around the inner tube in a continuous process that welds a fabric and/or non-fabric material, preferably using hot air, into the jacket.

[0027] Referring now to the drawings wherein like reference numbers refer to like parts throughout the several views, a hose assembly 10 is illustrated in FIGS. 1 and 2, wherein FIG. 1 illustrates the hose assembly in an out-of-service or contracted position and FIG. 2 an expanded position. Hose assembly 10 includes an inlet 14 and an outlet 16, with fluid passage 12 being located therebetween. The hose assembly includes an inner tube 20 that extends between and fitting or couplers, see for example male coupler 60 and female coupler 50. The inner tube 20 is self-expanding and self-contracting. Inner tube 20 has an inner surface 22 and an outer surface 24, see FIGS. 1-2, for example. When a fluid, such as water when the hose assembly is utilized as a garden hose, is introduced into the inner tube 20 and exerts at least a minimum fluid pressure on an inner surface 22, the inner tube 20 expands, generally radially, from a first circumference to a larger, second circumference in an expanded position; and longitudinally between the couplers 50, 60. In some embodiments the inner tube 20 is formed from a material that can expand longitudinally to a length that is generally at least two times, desirably between 2 and 4 times and preferably at least four times the length of the inner tube 20 when in a relaxed or contracted position. Inner tube 20 can be formed such that the second circumference provides the tube inner surface 22 with a desired inner diameter, for example about 0.5 inch (1.27 cm) or about 0.625 inch (1.59 cm). When fluid pressure decreases below the minimum fluid pressure, the inner tube 20 relaxes or contracts radially, preferably back to the first circumference in one embodiment. In other embodiments, the inner tube may not contract to the first circumference.

[0028] The thickness of the inner tube 20 can vary depending upon the materials utilized to construct the same. In various embodiments, the wall thickness of the inner tube ranges generally from about 1.0 to about 2.0 mm, desirably from about 1.2 to about 1.8 mm, preferably from about 1.40 to about 1.65 mm, as measured in a radial direction in a contracted position.

[0029] Hose assembly 10 also includes a jacket sheath or outer tube 40 that is also connected between first and second couplers, see for example male couplers 60 and female couplers 50. In one embodiment, the outer tube 40 is not connected or attached to the inner tube 20 or an outer slip coating layer 30, further described below, between the couplers. Stated in another manner, the outer tube 40 is preferably unattached, unconnected, unbonded, and unsecured to either the inner tube 20 or slip coating layer 30, when present, along the entire length of the inner tube 20 and slip coating layer 30 between the first end and the second end of the outer tube 40, and thus the tube 40 is able to move freely with respect to the inner tube 20 and/or slip coating layer 30 when the hose assembly expands or contracts. In one embodiment, the longitudinal and circumferential or radial expansion of inner tube 20 is limited by the dimensions, i.e. maximum length and/or inner diameter or circumference of outer tube 40. The outer tube 40 is configured to protect the inner tube 20 and slip coating layer 30, when present, such as from cuts, friction, abrasion, puncture, over-expansion (bursting) or UV exposure.

[0030] In various embodiments the outer tube 40 can be braided or woven into a fabric that is subsequently formed into the tube. Non-woven fabrics are utilized in some embodiments. In additional embodiments, the outer tube is formed from a non-fabric material, such as a film, fiber-reinforced film, sheet or similar construction. Suitable materials include, but are not limited to, polyolefins, polyesters, and polyamides such as nylon. Natural materials can be used in some embodiments. Polyester is preferred in some embodiments. Outer tube 40 should be formed from a material that is pliable and strong enough to withstand a desired internal pressure that can be exerted by outer surface 24 of inner tube 20. Thickness of the outer tube 40 is dependent on yarn denier when fabric-like materials are used. This will be dictated by desired internal pressure as mentioned above.

[0031] In some embodiments, the hose assembly 10 is formed such that the outer tube 40 has an outer diameter between about 0.635 cm and 2.175 cm or between 1.27 cm and 2.54 cm when the inner tube 20 is subjected to a pressure of about 413.7 kPa (about 60 psi). This inner tube can be pressurized using any suitable method such as, but not limited to, the burst strength test method described herein modified such that the inner tube is pressurized to the defined pressure. The outer diameter can be measured with a caliper.

[0032] In an important aspect of the present invention, the hose assembly jacket or outer tube 40 is formed around the inner tube 20, preferably in a continuous process. In a preferred embodiment a hot air welding process is utilized. While the process described utilizes the term "fabric", it is to be understood that the process is applicable to each of, and is thus inclusive of, the materials described herein. During the process, a piece of fabric (or other material) having first and second ends and first and second sides located therebetween is formed into a tubular shape. A portion of the first side and the second side is heated to a temperature where the material, in particular polymer, that forms the fabric melts and the sides are bonded together, with the inner tube being present within or surrounded by the outer tube formed by the fabric. A weld 46 is formed in the area where the fabric is heated and the sides are joined. As the fabric is joined along the length of the sides, the welded fabric forms a spine or weld seam 48 extending longitudinally along the length of the fabric, comprising melted fabric. In a preferred embodiment, the weld seam has an overlap or weld width of 0.375 inch (9.5 mm) +/- 0.0625 inch (+/- 1.5 mm), generally measured perpendicular to the longitudinal length of the weld seam. In another embodiment, the variation is +/- 3 mm. In one embodiment, the process that forms the welded seam is a continuous process that heats the fabric with hot air, with temperatures ranging between 550 and 750°C and preferably between 600 and 700°C. The welding process also produces a weld seam having a wall thickness that is generally at least 50% greater, desirably at least 75% greater and preferably about 100% greater, i.e. two times greater, than the average thickness of the non-welded fabric of the outer tube.

[0033] In one embodiment, the inner tube 20 is supplied from a reel or spool. In another embodiment, the inner tube 20 is supplied directly from an upstream extrusion line. The inner tube enters a folding fixture which contains a series of guides and is combined with a flat, woven fabric. The fabric is supplied from a fabric source, such as a bulk container and straightened and tensioned as it enters the folding fixture. The folding fixture forms the fabric around the inner tube, shapes the fabric into a round, tubular shape, and forms the correct or desired overlap for welding. The tubular fabric profile and inner tube exit the folding fixture. At the exit of the folding fixture, a nozzle directs hot air between the overlapped fabric side surfaces. This hot air heats the fabric to or above its melting point just before the fabric and inner tube pass through a set of nip rollers which force the heated fabric surfaces against each other under pressure. A strong bond between the two fabric surfaces is formed at this point. The fabric and tube may be wound onto a reel for future assembly or cut to length and processed into a finished hose immediately. Hot air seaming devices are available from companies such as Miller Weldmaster of Navarre, OH.

[0034] Inner tube 20 can be formed from any suitable elastic or polymeric material. Elastomeric materials are preferably utilized when inner tube 20 is longitudinally expandable. Suitable materials include, but are not limited to, rubbers including natural rubber, synthetic rubber and combinations thereof; thermoplastics; and various thermoplastic elastomers including thermoplastic vulcanizates. Suitable thermoplastic elastomers include but are not limited to styrenic block copolymers, for example SEBS, SEEPS, and SBS; and SIS. In one embodiment the elastomeric inner tube has a hardness that ranges from 20 to 60 Shore A, desirably from 25 to 60 Shore A, and preferably from 30 to 50 Shore A, as measured according to ASTM D-2240. Suitable thermoplastics include but are not limited to polyvinyl chloride (PVC). Non-limiting examples of suitable grades of PVC include standard and high molecular weight. Thermoplastic-containing inner tubes have a hardness that ranges from 50 to 80 Shore A, and preferably from 60 to 70 Shore A, as measured according to ASTM D-2240. In various embodiments, the inner or expandable tubes or any constructions described in one or more of the following patents and publications can be utilized and are herewith incorporated by reference: U.S. Patent Nos. 6,948,527; 7,549,448;

8,371,143; 8,776,836; 8,291,942; 8,479,776; 8,757,213; 8,936,046; 9,022,076; as well as U.S. Patent Application Publication Nos. 2014/0150889; 2014/0345734; 2015/0007902; 2015/0041016; 2015/0129042 and International Publication Nos. WO2014/169057; and WO2015/023592.

[0035] The inner tube compositions of the present invention may include additional additives including, but not limited to antioxidants, foam agent, pigments, heat stabilizers, UV absorber/stabilizer, processing aids, flow enhancing agents, nanoparticles, platelet fillers and non-platelet fillers.

[0036] In some embodiments of the present invention, slip coating layer 30 is provided on outer surface 24 of inner tube 20, see FIGS. 1 and 2. In a preferred embodiment, the slip coating layer 30 can be extruded onto or coextruded with the inner tube 20 layer. Other application methods such as coating would also be acceptable so long as the slip coating performs its intended function. In some embodiments of the present invention, a slip coat may not be necessary depending on the inner tube materials selected and the manufacturing method.

[0037] The slip coating layer 30 can be a continuous or discontinuous layer or layers. In one preferred embodiment the slip coating layer is continuous, at least prior to a first expansion of inner tube 20 after the slip coating layer has been applied. Depending on the thickness of the slip coating layer 30 relatively thin layers, after one or more expansions of the inner tube 20, may exhibit cracking, splitting, crazing, fracturing or the like. Importantly though, such layers have still been found to be effective. That said, the initial thickness of the slip coating layer 30 ranges generally from about 0.025 mm to about 0.51 mm, desirably from about 0.05 to about 0.25 and preferably from about 0.10 to about 0.20 mm, or about 0.15 mm measured in a radial direction.

[0038] As illustrated in FIGS. 1 and 2, the slip coating layer 30 is located between the inner tube 20 and the outer tube covering 40. In a preferred embodiment, the slip coating layer is not directly connected to the outer tube covering 40 between the first coupler and the second coupler, e.g. male coupler 60 and female coupler 50, such that the outer tube covering 40 can slide or otherwise move in relation to the slip coating layer 30 during expansion and contraction of hose assembly 10. In an

expanded position, the outer surface of the slip coating layer 30 is in contact with the inner surface of the outer tube covering 40.

[0039] The slip coating layer comprises a lubricant, optionally incorporated into or blended with a carrier material.

[0040] In one embodiment, the lubricant is a siloxane polymer or copolymer, or a fluorinated polymer or a combination thereof. A siloxane polymer masterbatch is available from Dow-Corning, such as MB50-321™, and from Wacker as Genioplast™. Fluorinated polymer is available from McLube as MAC 1080™. In some embodiments lubricant is present in the slip coating layer in an amount generally from about 1 to about 40 parts, desirably from about 2 to about 30 parts and preferably in an amount from about 3 to about 20 parts based on 100 total parts by weight of the slip coating layer. In other embodiments, the lubricant can be a liquid, semi-solid or solid material that serves to reduce friction between the inner tube and the outer tube. Non-limiting examples of other lubricants include, but are not limited to, oils such as silicone oil, waxes, polymers, including elastomers.

[0041] As described herein, in one embodiment the lubricant is mixed with a carrier material that aids in affixing the lubricant on an outer surface of the inner tube. Suitable materials include, but are not limited to, polyolefins, thermoplastic elastomers or a combination thereof. In one embodiment, the carrier material comprises a polyolefin and one or more of the thermoplastic elastomers utilized in the inner tube layer.

[0042] Along with the lubricant, the slip coating layer may also include additional additives including, but not limited to, antioxidants, foaming agents, pigments, heat stabilizers, UV absorber/stabilizer, processing aids, flow enhancing agents, nanoparticles, platelet fillers and non-platelet fillers. Various other lubricants or slip coating layers known to those of ordinary skill in the art may also be utilized, if desired.

[0043] Hose assembly 10 includes male coupler 60 at a first end and female coupler 50 at a second end. The male coupler 60 includes an external threaded section 62 and an internal connector 63 fixedly connected, such as by a press fit, to main body 66 of male coupler 60. Connector 63 includes a stem 64 initially having a smaller diameter portion 63 that is connected to a larger diameter portion connected to the

inner side of threaded section 62. Fluid passing through male coupler 60 passes through internal connector 63, generally through aperture 67 in stem 64 and out through the end of connector 63 within threaded section 62. In one embodiment, the stem 64 is inserted into the inner tube 20. A portion of the outer tube covering 40 is also located between stem 64, inner tube 20 and the ferrule 68 of male coupler 60. Inner tube 20 and outer tube 40 are operatively connected and secured to male coupler 60 by expansion of the stem 64 outwardly towards ferrule 68. In other embodiments the ferrule can be crimped towards a relatively rigid stem in order to capture the inner tube and outer tube therebetween, securing the tubes to the male coupler 60. Other attachment mechanisms could also be utilized.

[0044] The female coupler 50 includes a main body 56 having an internal threaded section 52 that is operatively and rotatably connected to a second end of hose assembly 10 opposite the end containing male coupler 60. Threaded section 52 is constructed such that it can be operatively connected to a male fitting of a spigot, faucet, or other similar valve control device.

[0045] The internal connector 53 of female coupler 50 is rotatable in relation to main body 56 such that the main body is also rotatable in relation to the inner tube 20 and outer tube 40 which are operatively connected or fixed to stem 54. A ferrule 51 is placed onto the jacket or outer tube 40 and inner tube 20. The ferrule 51, inner tube 20, and fabric jacket outer tube 40 are then fitted onto stem 63. Stem 63 is then expanded to secure the hose to the fitting. As mentioned above with respect to the male coupler, alternative constructions can be utilized to secure the inner tube 20 and outer tube 40 to the female coupler 50. As illustrated in FIG. 1, connector 53 includes a receptacle 55 in the form of a cavity, recess, or the like that accommodates flange 57 of the main body 56. In the embodiment illustrated, the flange 57 is a ring-like feature projecting inwardly from the main body 56 and includes an end that is located within receptacle 55. The flange structure allows the main body 56 to spin or rotate around connector 53. A washer 59 is located at the base of threaded section 52 in order to provide a desired seal between the female coupler and a device that is threadably connectable to threaded section 52.

[0046] Alternatively, other common couplers, fittings or hose end connections can be utilized and include, but are not limited, crimped (external), barbed, or clamped couplings made from plastics, metals, or combinations thereof.

[0047] The hose assembly 10 is illustrated in a contracted position with respect to length and circumference in FIG. 1. In this position, the elastic inner tube 20 is in a contracted or relaxed state with no internal force being applied to the inner surface 22 sufficient to expand or stretch inner tube 20. Depending on the material utilized for outer tube covering 40, space may exist between the same and the slip coating layer 30, if present, and/or inner tube 20 when the hose assembly is in a contracted position.

[0048] The fluid pressure within inner tube 20 can be increased for example by preventing fluid from being expelled through outlet 16, such as with the use of an associated nozzle or the like (not shown) and introducing fluid under pressure into the inlet 14 of hose assembly 10. Once a minimum threshold pressure is met or exceeded, the inner tube 20 undergoes longitudinal and/or circumferential expansion. Expansion of inner tube 20 results in a decrease in wall thickness of the inner tube and an increase in the circumference or diameter of the inner tube and/or the length of the inner tube in some embodiments. Thus, a higher volume of fluid can be present in inner tube 20 in the expanded position as compared to the volume of fluid that can be present in a contracted position, below the minimum fluid pressure.

[0049] Depending upon the construction of the outer tube covering 40, in the expanded position, the covering may exhibit a relatively smooth, cylindrical character along its length, see FIG. 2 for example.

[0050] Standard water pressure for water exiting a spigot from a municipal water system is about 45 to about 75 psi (310.3 to 517.1 kPa) and typically about 60 psi, 413.7 kPa. Such pressure is sufficiently above a minimum fluid pressure required for the hose to expand. The minimum fluid pressure that causes the inner tube 20 of hose assembly 10 to expand will vary depending on the construction or composition thereof. When a nozzle or other flow restricting device is connected to the male coupler 60 of hose assembly 10, with the female coupler 70 being operatively connected to a spigot, the inner tube 20 will expand when the spigot valve is opened

or turned on as water under pressure will flow into the hose. If the nozzle prevents the flow of fluid through the inner tube, the pressure inside the inner tube will achieve substantially the same pressure as that coming from the fluid pressure source, such as 60 psi (289.6 kPa) in the case of a standard municipal water supply. When fluid is released from the outlet 16 of hose assembly 10 through a suitable nozzle, the pressure inside the inner tube 20 is reduced. The hose assembly will remain in an expanded position when the fluid pressure remains above the minimum fluid pressure. In a preferred embodiment, the couplers are full flow fittings. They are not designed to create back pressure within the hose.

[0051] The hose assemblies formed by the present invention are relatively lightweight, when compared to a conventional garden hose. Hose assemblies of the present invention are capable of withstanding water pressures in the 400 psi (2758 kPa) range while still being relatively light. For example, a 50 foot hose assembly of the present invention including couplers or end fittings can weigh about 4 or 5 lbs. with inner and outer tubes that are about 50 feet in length.

[0052] The hose assemblies of the present invention can also be characterized by a given or combined i) weight of both the inner tube and outer tube per length or ii) linear mass density. The constructions described herein provide a hose assembly with an inner tube and outer tube having a total combined weight of generally between 74.4 g/m and 163.68 g/m, or between 89.28 g/m and 148.80 g/m, or between 96.72 g/m and 133.92 g/m.

[0053] Regarding the ability of the hose assemblies of the present invention to withstand water pressure or other fluid pressure within a desired range, the inner tube and outer tube have a certain burst strength. When utilized herein, burst strength is defined as the pressure measured inside the inner tube at the first failure of one of the inner tube and outer tube, measured between 20°C to 24°C. The burst strength depends on the construction of the hose assembly. In some embodiments the outer tube, such as an outer textile or fabric jacket may fail via a rupture or tear prior to failure of the inner tube. Failure of the inner tube is characterized by a rupture causing leakage of the fluid from within the inner tube. The hose assemblies of the present invention in preferred embodiments have an inner tube and outer tube that have a

burst strength between 1,379 kPa and 8,274 kPa or 8,963 kPa or 10,342 kPa, or between 2,758 kPa and 6,895 kPa, or even between 4,137 kPa and 6,205 kPa measured according to the burst strength test of ASTM D380-94(2012).

[0054] The burst strength test is performed using the straight bursting test procedure. A section of a hose assembly containing an inner tube and outer tube to be tested is cut to a length of 61 cm +/- 7.62 cm, (about 2 feet +/- 3 inches). A male coupler is connected to a first end of the hose section including the inner tube and outer tube and a female coupler is connected to a second end of the section. The female coupler is connected to a male fitting of a testing apparatus that includes a reservoir holding a sufficient volume of water to complete the test. The test sample is suspended vertically in the testing apparatus. Air in the hose is allowed to escape before the test is performed. The male coupler is capped. The water temperature is maintained at a temperature of 20°C to 24°C, for example by utilizing a heater element and/or cooling element. The test apparatus includes a positive displacement pump rated at 2.2 gallons per minute and 1,000 psi. The pump is driven by an electric motor. The pump transfers water through a fluid line past a pressure transducer, such as available from Dynisco of Franklin, MA as Model PT130-1M that measures fluid pressure, with the hose section to be tested located in the fluid line downstream from the pressure transducer. The testing apparatus can also include a pressure relief valve that can be set to open at a predetermined pressure, such as 1,000 psi, to prevent pressure from building to levels that would damage the pump or plumbing of the testing apparatus. After the hose section is connected to the testing apparatus, the pump is actuated and water flows from the pump, past the pressure transducer, and into the hose section that is capped at the male end. The pressure increases in the process line between the pump and valve and is displayed on a Dynisco Model 1290 display, with peak hold capability, of the pressure transducer. The pressure at which the first failure of the inner tube or the outer tube is observed is recorded as the burst strength. The burst strength test takes place with the hose section submerged in water in order to absorb some of the energy released when the hose bursts.

[0055] The hose assemblies of the present invention are also characterized, in some embodiments, by a burst strength per linear mass density, e.g. kPa/(g/m) or kPa·m/g.

The constructions described herein provide a hose assembly with an outer tube and inner tube collectively having a burst strength per linear mass density generally between 18.53 kPa•m/g to 100 kPa•m/g, or between 30.89 kPa•m/g and 95 kPa•m/g, or even between 42.77 kPa•m/g and 85 kPa•m/g. The above-listed ranges are particularly applicable when the inner tube comprises a thermoplastic material. Constructions including thermoplastic inner tubes of the present invention can provide light weight and high burst strength. In other embodiments, the constructions provide a hose assembly with an outer tube and an inner tube collectively having a burst strength per linear density between 52 kPa•m/g to 100 kPa•m/g or between 52 kPa•m/g to 95 kPa•m/g or even 55 kPa•m/g to 85 kPa•m/g. For the sake of clarity, the inner tube in such constructions can comprise one or more of an elastomeric material and a thermoplastic material. As described hereinabove, the burst strength is measured according to the burst strength test of ASTM D380-94(2012).

[0056] In view thereof, it is clear that the hose assemblies of the present invention exhibit very desirable burst strengths per linear mass density for the outer tube and inner tube sets and are thus suitable for many different applications and in particular for garden-type hoses. The hose assemblies of the present invention offer many advantages and are able to achieve high burst strengths while being relatively light in weight, as indicated by the desirable burst strengths per linear mass density. Generally speaking about some prior art constructions, lighter and/or thinner hose constructions in some embodiments can have relatively low burst strengths while relatively thick and/or heavy hose constructions can achieve higher burst strengths in some embodiments. The inventors have beneficially achieved increases in burst strength while realizing relatively low weight per length as embodied in the burst strength per linear mass density parameter.

[0057] The hose assemblies are very flexible and can be easily stored in compact spaces that a conventional garden hose would not fit, such as a bucket or similar container. The hot air seaming or welding process according to the present invention allows manufacture of a hose assembly utilizing less labor input, while having the inner tube automatically inserted into the outer tube which is formed therearound as part of the welding process.

[0058] The hose assemblies of the present invention are particularly suitable for cold water applications.

[0059] Due to the flexibility and versatility of the hose assemblies, one can utilize a fastener system such as a hook and loop fastener system, for example VELCRO® to harness the hose assembly when not in use. A fastener strap can be attached to one end of the hose by threading an end of a fastener through a female eyelet thereof such that the fastener can be permanently affixed to the hose assembly.

[0060] The hose assemblies of the present invention can also be formed from FDA listed ingredients for non-food contact applications, such as RV and marine drinking water service.

[0061] Examples

[0062] Elevated Temperature Burst

[0063] Garden hose assemblies as described in the example above were burst tested at 120°F to determine how they would perform in hot conditions. This inventive construction did not lose as much burst strength at high temperatures compared to existing constructions.

[0064] Puncture Resistance

[0065] A pointed penetrator was forced against a pressurized hose assembly as described above. The peak force required to form a leak was recorded. This construction was comparable to heavy duty, conventional constructions.

[0066] Burst Strength Test and Weight per Length Comparison

[0067] The following hose assemblies were compared in Table 1 based on weight per length and the burst strength test. Burst strength was measured according to the burst strength test described herein. The weight per length of hose was calculated from a 61 cm +/- 7.62 cm section of tube. The weight per length measurement excludes the weight of any end couplers or fittings. The weight was measured using a digital laboratory balance reporting the product weight in grams.

[0068] The following hose assemblies were tested:

Example 1	The inner tube included high molecular weight PVC and the outer tube was woven polyester produced from 840 denier thread in the warp and weft directions, with a weld seam present along the length of the outer tube.
Example 2	The inner tube included high molecular weight PVC and the outer tube was woven polyester produced from 840 denier thread in the warp and weft directions, with a weld seam present along the length of the outer tube.
Comparative Example 1	Telebrands Corp of Fairfield, NJ
Comparative Example 2	Flexible™ (2016) Flexible Extreme (Sam's Club) available from Tristar Products, Inc. of Fairfield, NJ
Comparative Example 3	X-hose™ (2016) PRO Extreme available from National Express, Inc. of Norwalk, CT
Comparative Example 4	Teknor Apex light duty (model 8500) from Teknor Apex, Pawtucket, RI
Comparative Example 5	Teknor Apex Medium duty (model 8535)
Comparative Example 6	Teknor Apex Heavy duty Neverkink® (model 8692)

Table 1

Test	Comp Ex. 1	Comp Ex. 2	Comp Ex. 3	Comp Ex. 4	Comp Ex. 5	Comp Ex. 6	Ex. 1	Ex. 2
Weight per Length (g/m)	52.4	56.5	55.4	154.2	165.68	237.9	122.3	104.2
Burst Strength (kPa)	2641	2399	2537	1551***	2068***	2757***	6500*	7374**
Burst strength per linear mass density (kPa*m/g)	50.4	42.5	45.8	10.1	12.5	11.6	53.1	70.8

*Average of 700 tests

**Average of 2 tests. The tested hoses did not fail and the value listed represents the average highest pressure achieved before the pressure relief valve opened.

***Specification

[0069] As shown in Table 1, the examples of the present invention have relatively high burst strength test results while still being relatively light in weight, as compared to conventional single tube garden hoses. Examples 1 and 2 also exhibit desirable burst strength results and burst strength per linear mass density as compared to the comparative examples, especially in relation to Comparative Examples 1 to 3 which comprise elastomeric inner tubes. Comparative Examples 4-6 comprise thermoplastic materials. Examples 1 and 2 achieve better burst strength and burst strength per linear mass density results than such constructions.

[0070] The invention further relates to the following:

[0071] 1. A hose assembly, comprising: an inner tube comprising one or more of an elastomeric material and a thermoplastic material, wherein the inner tube has a first longitudinal length and a first circumference below a minimum expansion pressure, wherein the inner tube is expandable to one or more of a) a longer, second longitudinal length and b) a larger, second circumference upon application of fluid pressure on an inner surface of the inner tube at or above the minimum expansion pressure; and an outer tube covering the inner tube, the outer tube having a longitudinal length and a weld seam along the longitudinal length of the outer tube, the weld seam comprising melted outer tube material.

[0072] 2. The hose assembly according to 1, wherein the outer tube has a first end and a second end and two sides between ends, wherein the two sides are bonded at the weld seam, and wherein the second longitudinal length is at least two times greater than the first longitudinal length.

[0073] 3. The hose assembly according to 1 or 2, wherein the outer tube has an inner surface with a circumference and the second circumference of the inner tube is less than or equal to the outer tube inner surface circumference.

[0074] 4. The hose assembly according to any of 1-3, wherein the hose assembly further includes a male coupler connected to first ends of the inner tube and the outer tube and a female coupler connected to second ends of the inner tube and the outer tube.

[0075]5. The hose assembly according to any of 1-4, wherein the hose assembly further includes a slip coating layer directly contacting the inner tube.

[0076]6. The hose assembly according to any of 1-5, wherein the weld seam has a weld width of 9.5 mm +/- 3.0 mm, and wherein the weld seam has a weld thickness that is at least 50% greater than a thickness of the fabric of the outer tube in a non-weld seam section.

[0077]7. The hose assembly according to 6, wherein the weld seam weld width is 9.5 mm +/- 1.50 mm, and wherein the weld thickness is at least 75% greater than the thickness of the material of the outer tube in the non-weld seam section.

[0078]8. The hose assembly according to 7, wherein the weld seam weld thickness is at least 100% greater than the thickness of the material of the outer tube in the non-weld seam section.

[0079]9. The hose assembly according to any of 1-8, wherein the inner tube comprises the thermoplastic material, wherein the thermoplastic material comprises polyvinylchloride, and wherein the inner tube is expandable to the larger, second circumference.

[0080] 10. The hose assembly according to any of 1-8, wherein the inner tube comprises the elastomeric material, and wherein the inner tube is expandable to both the longer, second longitudinal length and the larger, second circumference.

[0081]11. A process for producing a hose assembly, comprising: obtaining an inner tube comprising one or more of an elastomeric material and a thermoplastic material, wherein the inner tube has a first longitudinal length and a first circumference below a minimum expansion pressure, wherein the inner tube is expandable to one or more of a) a longer, second longitudinal length and b) a larger, second circumference upon application of fluid pressure on an inner surface of the inner tube at or above the minimum expansion pressure; obtaining a material having a first end, a second end, a first side and a second side, the sides located between the ends; wrapping the material around the inner tube and abutting the first side and the second side of the material, and heating the material to melt and bond the first side to the second side along a length of the sides thereby forming an outer tube having a weld seam along a

longitudinal length of the hose assembly, wherein during formation of the outer tube a section of the inner tube is located inside the outer tube.

[0082] 12. The process according to 11, further including the step of overlapping the first side and the second side of the fabric 9.5 mm +/- 3.0 mm.

[0083] 13. The process according to 12, further including the step of overlapping the first side and the second side of the fabric 9.5 mm +/- 1.5 mm.

[0084] 14. The process according to any of 11-13, wherein the heating step comprises heating the material with hot air at a temperature between 550°C and 750°C.

[0085] 15. The process according to any of 11-14, further including the step of partially forming the material around the inner tube with a folding fixture and shaping the material into a round, tubular profile using a die.

[0086] 16. The process according to any of 11-15, further including a step of passing the inner tube and outer tube through a set of rollers which force the heated material surfaces against each other under pressure after the heating step.

[0087] 17. The process according to any of 11-16, wherein the heating step comprises heating the material with hot air at a temperature between 100°C and 700°C.

[0088] 18. The process according to any of 9-17, wherein the second longitudinal length is at least two times greater than the first longitudinal length.

[0089] 19. The process according to any of 11-18, wherein the inner tube comprises the thermoplastic material, wherein the thermoplastic material comprises polyvinylchloride, and wherein the inner tube is expandable to the larger, second circumference.

[0090] 20. The process according to any of 11-18, wherein the inner tube comprises the elastomeric material, and wherein the inner tube is expandable to both the longer, second longitudinal length and the larger, second circumference.

[0091] 21. A hose assembly, comprising: an inner tube comprising one or more of an elastomeric material and a thermoplastic material, wherein the inner tube has a first longitudinal length and a first circumference below a minimum expansion pressure, wherein the inner tube is expandable to one or more of a) a longer, second

longitudinal length and b) a larger, second circumference upon application of fluid pressure on an inner surface of the inner tube at or above the minimum expansion pressure; an outer tube covering the inner tube, wherein the outer tube is not bonded, connected or attached to the inner tube between end couplers of the hose assembly; and wherein the inner tube and outer tube have a total weight between 74.4 g/m and 163.68 g/m, and a burst strength between 1,379 kPa and 10,342 kPa measured according to ASTM D380-94(2012).

[0092] 22. The hose assembly according to 21, wherein the inner tube and the outer tube have a total weight between 89.28 g/m and 148.80 g/m.

[0093] 23. The hose assembly according to any of 21-22, wherein the inner tube and the outer tube have total weight between 96.72 g/m and 133.92 g/m.

[0094] 24. The hose assembly according to any of 21-23, wherein the burst strength is between 2,758 kPa and 8,963 kPa.

[0095] 25. The hose assembly according to any of 21-24, wherein the burst strength is between 4,137 kPa and 8,274 kPa.

[0096] 26. The hose assembly according to any of 21-25, wherein the outer tube comprises a fabric material that is one or more of braided, woven and non-woven.

[0097] 27. The hose assembly according to any of 21-25, wherein the outer tube is formed from a film, fiber-reinforced film or sheet.

[0098] 28. The hose assembly according to any of 21-27, wherein the second longitudinal length is at least two times greater than the first longitudinal length.

[0099] 29. The hose assembly according to any of 21-28, wherein the second longitudinal length is between 2 and 4 times the first longitudinal length.

[0100] 30. The hose assembly according to any of 21-29, wherein the end fittings include a male coupler connected to first ends of the inner tube and the outer tube and a female coupler connected to second ends of the inner tube and the outer tube, and wherein the inner tube and outer tube collectively have a burst strength per linear density between 18.53 kPa•m/g to 63.18 kPa•m/g.

[0101] 31. The hose assembly according to any of 21-27 or 30, wherein the inner tube comprises the thermoplastic material.

[0102]32. The hose assembly according to 31, wherein the thermoplastic material comprises polyvinyl chloride, and wherein the inner tube is expandable to the larger, second circumference.

[0103]33. The hose assembly according to any of 21-30, wherein the inner tube comprises the elastomeric material, and wherein the inner tube is expandable to both the longer, second longitudinal length and the larger, second circumference.

[0104]34. The hose assembly according to any of 21-33, wherein the inner tube includes a slip coating layer directly contacting the inner tube.

[0105]35. The hose assembly according to any of 21-34, wherein the inner tube has a wall thickness from about 1.0 mm to about 2.0 mm measured in a radial direction in a contracted position.

[0106]36. The hose assembly according to any of 21-35, wherein the inner tube has a wall thickness from about 1.40 mm to about 1.65 mm measured in a radial direction in a contracted position.

[0107]37. The hose assembly according to any of 21-36, wherein the outer tube has a longitudinal length and a weld seam along the longitudinal length of the outer tube, the weld seam comprising melted outer tube material.

[0108]38. The hose assembly according to 37, wherein the weld seam has a weld width of 9.5 mm +/- 1.5 mm measured perpendicular to the longitudinal length.

[0109]39. A hose assembly, comprising: an inner tube comprising one or more of an elastomeric material and a thermoplastic material, wherein the inner tube has a first longitudinal length and a first circumference below a minimum expansion pressure, wherein the inner tube is expandable to one or more of a) a longer, second longitudinal length and b) a larger, second circumference upon application of fluid pressure on an inner surface of the inner tube at or above the minimum expansion pressure; an outer tube covering the inner tube, wherein the outer tube is not bonded, connected or attached to the inner tube between end couplers of the hose assembly; and wherein the inner tube and outer tube collectively have a burst strength per linear mass density between 52 kPa•m/g to 100 kPa•m/g, wherein burst strength is measured according to ASTM D380-94(2012), and wherein the inner tube and outer tube have a total weight between 74.4 g/m and 163.68 gm.

[0110]40. The hose assembly according to 39, wherein the inner tube and the outer tube have a total weight between 74.4 g/m and 163.68 g/m, and a burst strength between 1,379 kPa and 10,342 according to ASTM D380-94(2012).

[0111]41. The hose assembly according to any of 39-40, wherein the burst strength per linear mass density is between 52 kPa•m/g and 95 kPa•m/g.

[0112]42. The hose assembly according to any of 39-41, wherein the burst strength per linear mass density is between 52 kPa•m/g and 85 kPa•m/g.

[0113]43. The hose assembly according to any of 39-42, wherein the outer tube comprises a fabric material that is one or more of braided, woven and non-woven.

[0114]44. The hose assembly according to any of 39-43, wherein the second longitudinal length is at least two times greater than the first longitudinal length.

[0115]45. The hose assembly according to any of 39-44, wherein the second longitudinal length is between 2 and 4 times the first longitudinal length.

[0116]46. The hose assembly according to any of 39-45, wherein the end fittings include a male coupler connected to first ends of the inner tube and the outer tube and a female coupler connected to second ends of the inner tube and the outer tube.

[0117]47. The hose assembly according to any of 39-43 or 46, wherein the inner tube comprises the thermoplastic material.

[0118]48. The hose assembly according to any of 39-46, wherein the inner tube comprises the elastomeric material, and wherein the inner tube is expandable to both the longer, second longitudinal length and the larger, second circumference.

[0119]49. The hose assembly according to any of 39-48, wherein the inner tube has a wall thickness from about 1.2 mm to about 1.8 mm measured in a radial direction in a contracted position.

[0120]50. The hose assembly according to any of 39-49, wherein the outer tube has a longitudinal length and a weld seam along the longitudinal length of the outer tube, the weld seam comprising melted outer tube material, and wherein the weld seam has a weld width of 9.5 mm +/- 1.5 mm measured perpendicular to the longitudinal length.

[0121]While in accordance with the patent statutes the best mode and preferred embodiment have been set forth, the scope of the invention is not limited thereto, but rather by the scope of the attached claims.

WHAT IS CLAIMED IS:

1. A hose assembly, comprising:

an inner tube comprising one or more of an elastomeric material and a thermoplastic material, wherein the inner tube has a first longitudinal length and a first circumference below a minimum expansion pressure, wherein the inner tube is expandable to one or more of a) a longer, second longitudinal length and b) a larger, second circumference upon application of fluid pressure on an inner surface of the inner tube at or above the minimum expansion pressure; and

an outer tube covering the inner tube, the outer tube having a longitudinal length and a weld seam along the longitudinal length of the outer tube, the weld seam comprising melted outer tube material, wherein the hose assembly further includes a first coupler connected to first ends of the inner tube and the outer tube and a second coupler connected to second ends of the inner tube and the outer tube, and wherein the outer tube is not connected or attached to the inner tube between the first coupler and the second coupler.

2. The hose assembly according to claim 1, wherein the outer tube has a first end and a second end and two sides between ends, wherein the two sides are bonded at the weld seam, and wherein the outer tube has an inner surface with a circumference and the second circumference of the inner tube is less than or equal to the outer tube inner surface circumference.

3. The hose assembly according to any of claims 1-2, wherein the hose assembly further includes a slip coating layer directly contacting the inner tube.

4. The hose assembly according to any of claims 1-3, wherein the weld seam has a weld width of 9.5 mm +/- 3.0 mm, and wherein the weld seam has a weld thickness that is at least 50% greater than a thickness of the fabric of the outer tube in a non-weld seam section.

5. The hose assembly according to claim 4, wherein the weld seam weld thickness is at least 100% greater than the thickness of the material of the outer tube in the non-weld seam section.

6. The hose assembly according to any of claims 1-5, wherein the inner tube comprises the thermoplastic material, wherein the thermoplastic material comprises polyvinyl chloride, and wherein the inner tube is expandable to the larger, second circumference.

7. The hose assembly according to any of claims 1-6, wherein the inner tube comprises the elastomeric material.

8. The hose assembly according to claim 1, wherein the inner tube and outer tube have a total weight between 74.4 g/m and 163.68 g/m, and a burst strength between 1,379 kPa and 10,342 kPa measured according to ASTM D380-94(2012).

9. The hose assembly according to claim 8, wherein the burst strength is between 4,137 kPa and 8,274 kPa.

10. The hose assembly according to claim 9, wherein the inner tube and the outer tube have total weight between 96.72 g/m and 133.92 g/m, and wherein the inner tube and outer tube collectively have a burst strength per linear mass density between 18.53 kPa•m/g to 63.18 kPa•m/g.

11. A process for producing a hose assembly, comprising:

obtaining an inner tube comprising one or more of an elastomeric material and a thermoplastic material, wherein the inner tube has a first longitudinal length and a first circumference below a minimum expansion pressure, wherein the inner tube is expandable to one or more of a) a longer, second longitudinal length and b) a larger, second circumference upon application of fluid pressure on an inner surface of the inner tube at or above the minimum expansion pressure;

obtaining a material having a first end, a second end, a first side and a second side, the sides located between the ends;

wrapping the material around the inner tube and abutting the first side and the second side of the material, and

heating the material to melt and bond the first side to the second side along a length of the sides thereby forming an outer tube having a weld seam along a longitudinal length of the hose assembly, wherein during formation of the outer tube a section of the inner tube is located inside the outer tube.

12. The process according to claim 11, further including the step of overlapping the first side and the second side of the fabric 9.5 mm +/- 3.0 mm.

13. The process according to any of claims 11-12, wherein the heating step comprises heating the material with hot air at a temperature between 550°C and 750°C, further including the step of partially forming the material around the inner tube with a folding fixture and shaping the material into a round, tubular profile using a die, and further including a step of passing the inner tube and outer tube through a set of rollers which force the heated material surfaces against each other under pressure after the heating step.

14. The process according to any of claims 11-14, wherein the inner tube comprises the thermoplastic material, wherein the thermoplastic material comprises polyvinyl chloride, and wherein the inner tube is expandable to the larger, second circumference.

15. The process according to any of claims 11-14, wherein the inner tube comprises the elastomeric material.

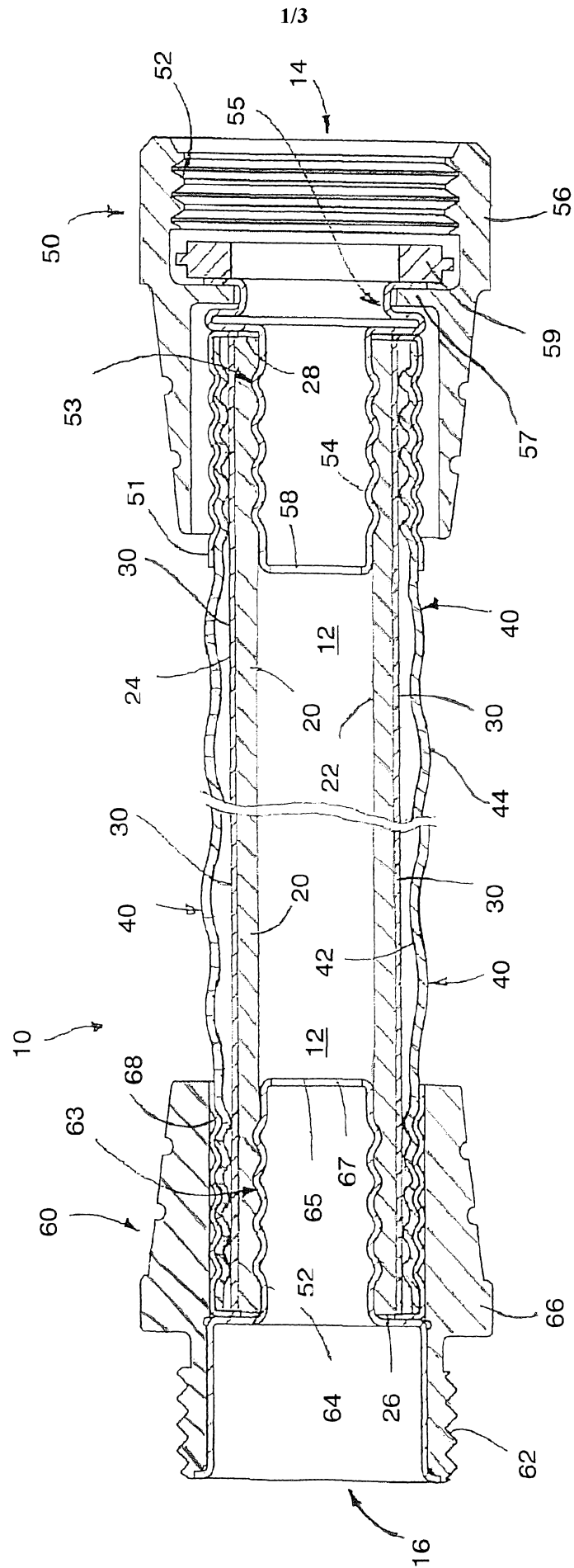

FIG. 1

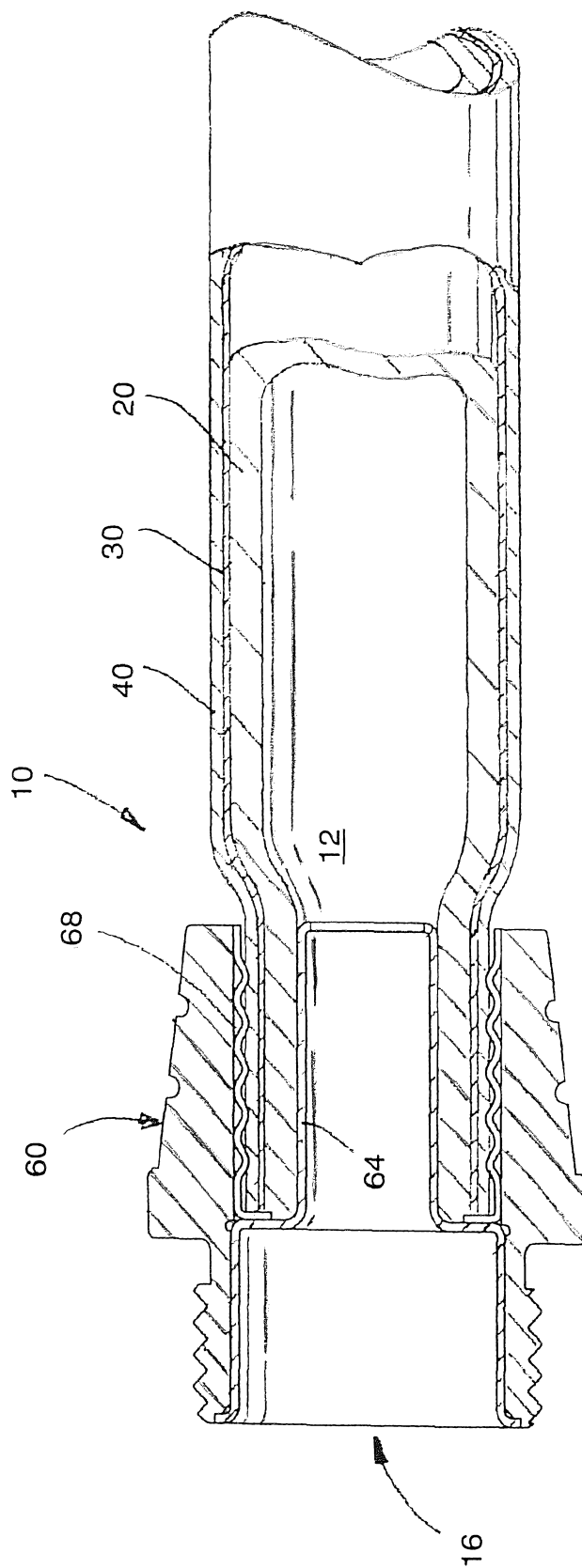

FIG. 2

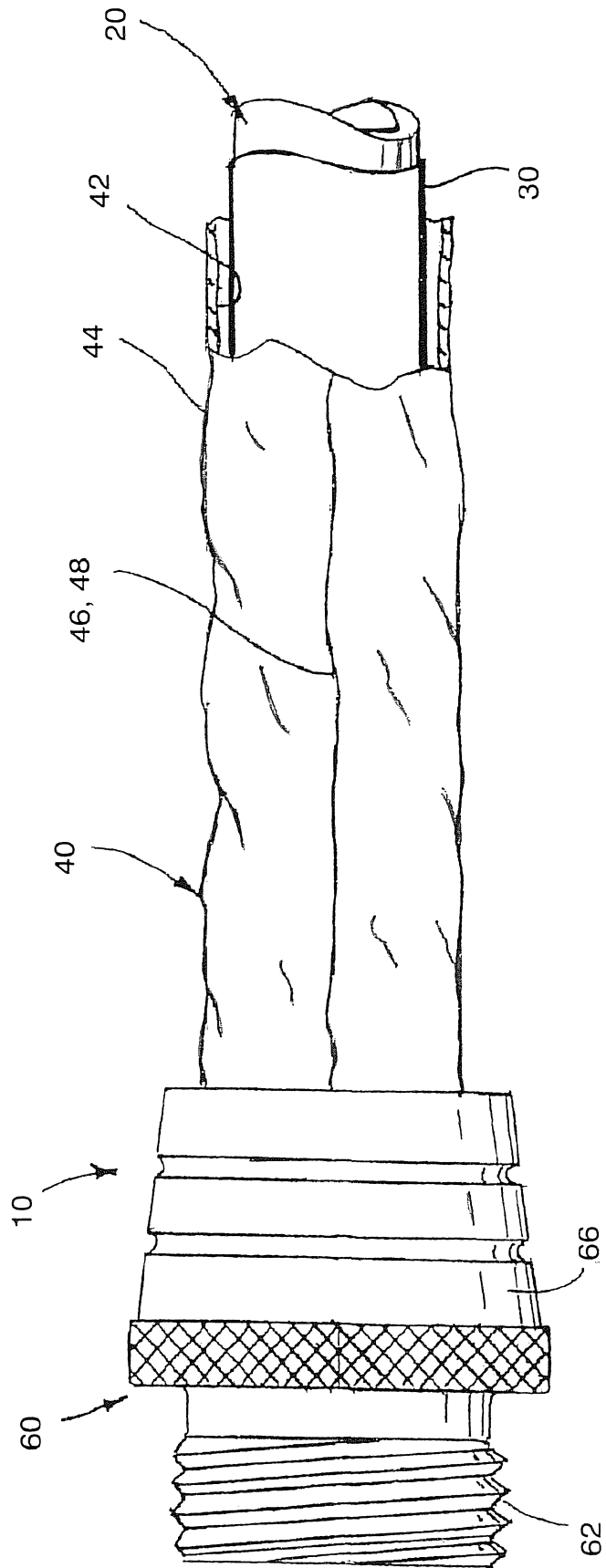

FIG. 3