

(No Model.)

W. T. REASER.

METHOD OF AND APPARATUS FOR HARDENING CAST STEEL.

No. 550,291.

Patented Nov. 26, 1895.

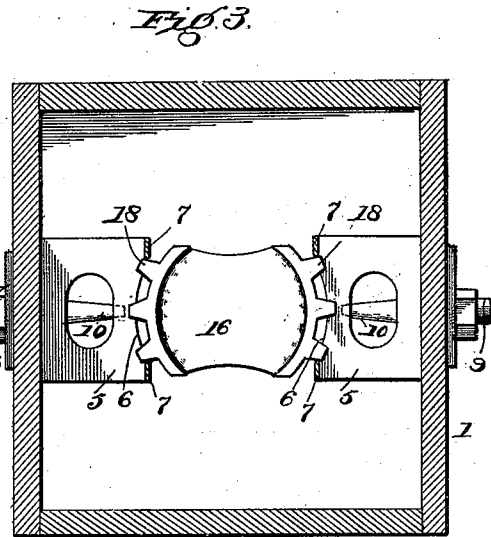
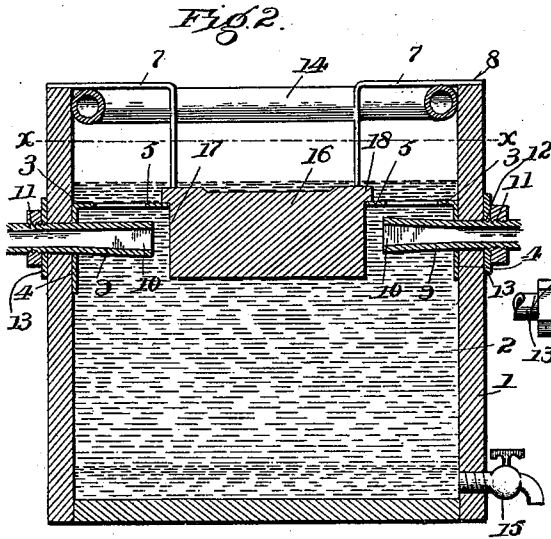
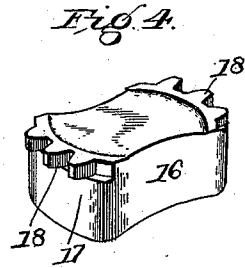
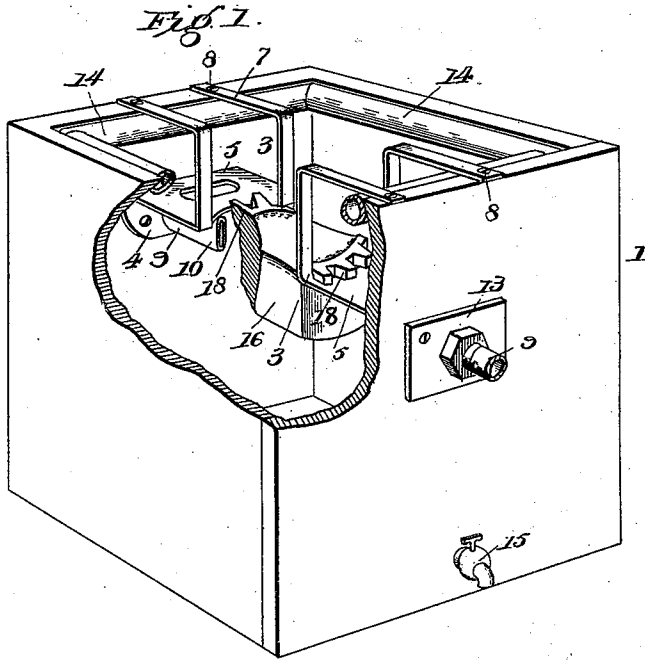

Inventor

Warren T. Reaser

Witnesses

A. M. Johnson
D. P. Hallenbeck

By *W. S.* Attorneys.

C. Snow & Co.

UNITED STATES PATENT OFFICE.

WARREN T. REASER, OF LINCOLN, NEBRASKA.

METHOD OF AND APPARATUS FOR HARDENING CAST-STEEL.

SPECIFICATION forming part of Letters Patent No. 550,291, dated November 26, 1895.

Application filed November 30, 1894. Serial No. 530,450. (No model.)

To all whom it may concern:

Be it known that I, WARREN T. REASER, a citizen of the United States, residing at Lincoln, in the county of Lancaster and State of Nebraska, have invented a new and useful Method of and Apparatus for Hardening Cast-Steel, of which the following is a specification.

This invention relates to an improvement in the method of and apparatus for hardening cast-steel; and it has for its object to provide a new and useful construction of hardening apparatus involving a method that will positively insure the homogeneous hardening of cast-steel, and also for the extra hardening of any particular part or parts of the casting requiring great strength and a hard wearing-surface.

To this end the invention primarily contemplates a simple and efficient method for hardening steel castings of all kinds and an apparatus for carrying out the method, and which is particularly adapted for hardening rolling supports for balanced slide-valves, such as set forth in Reissue Patent No. 10,449, granted to me February 12, 1884.

With these and other objects in view the invention consists of the improved method and apparatus, as herein described, illustrated, and claimed.

In the drawings, Figure 1 is a perspective view, partly in section, of a hardening apparatus constructed in accordance with this invention, showing a rolling slide-valve support arranged in position for being hardened. Fig. 2 is a central vertical sectional view of the same. Fig. 3 is a horizontal sectional view on the line *xx* of Fig. 2. Fig. 4 is a detail in perspective of the form of rolling valve-supports in connection with which the apparatus is especially employed.

Referring to the accompanying drawings, 1 designates a tank or tub of any suitable size or capacity and adapted to contain therein a bath of oil, (indicated by the reference-numeral 2,) and sufficient oil is designed to be placed in the tank or tub 1 to cover the opposite supporting-plates 3, that are located at diametrically-opposite inner sides of the tank or tub, near the top thereof. The opposite supporting-plates 3 are preferably L-shaped and have the vertical flanges 4 thereof resting against and secured to the inner sides of the tank 1,

and the horizontal portions 5 of said plates project inwardly from the sides of the tank or tub and are provided with segmentally-curved inner edges 6. The horizontal portions 5 of the supporting-plates 3 have extended integrally from the inner corners thereof the upwardly-disposed L-shaped securing-arms 7, that are suitably fastened at their upper ends, as at 8, to the upper edge of the tank or tub 1 to provide for firmly securing the supporting-plates properly in position within the tank or tub at opposite inner sides thereof.

The opposite inner supporting-plates 3 have arranged directly under the horizontal portions thereof the opposite inwardly-disposed jet-nipples 9. The opposite inwardly-disposed jet-nipples 9, that are arranged under each supporting-plate, are provided with inner vertically-disposed contracted discharge-mouths 10, that provide for discharging a narrow stream of water into the tank or tub, and said jet-nipples are provided with outer exteriorly-threaded ends 11, that are preferably threaded into the threaded openings 12 of the screw-plates 13, fastened on the outside of the tank or tub 1 at diametrically-opposite sides thereof, and by screwing the nipples in either direction through the openings of the plates 13 the nipples may be properly adjusted to vary the position of the discharging-mouths thereof as the requirements of the apparatus may demand. The said jet-nipples are also designed to have connected therewith suitable piping to provide for forcing streams of water therethrough while the apparatus is in operation.

In order to maintain the bath of oil in the tank or tub at the proper temperature to prevent the overheating and firing thereof, an annular perforated spray-pipe 14 is arranged within the upper part of the tank or tub above the level of the oil, and in order to provide for draining the water in the bottom of the tank or tub as fast as it is introduced therein by the spray-pipe a suitable drain cock or pipe 15 may be connected with the bottom of the tank or tub, as will be obvious.

In hardening a casting of steel it is simply necessary to first heat such casting to about a cherry-red heat and then place the same between and on the supporting-plates 3 in the

tank, and said supporting-plates are designed to support the casting, so that the same will be entirely submerged in the bath of oil in order to receive a homogeneous oil hardening throughout its entire body. The parts of the casting which project below the horizontal portions of the supporting-plate will be arranged directly opposite or adjacent to the inner discharging ends of the jet-nipples, and these portions of the casting can be additionally hardened by directing streams of water from the jet-nipples thereagainst. Such streams of water necessarily force the oil away from the surface of the casting, so that the water will come in direct contact therewith.

The special form of casting that is especially designed for use in connection with the herein-described apparatus is a rolling slide-valve support 16 of the construction shown in Fig. 4 of the drawings. The rolling slide-valve support 16 is substantially the same construction of valve-support as shown in my reissue patent already referred to and in Patent No. 404,363. The support 16 is provided with opposite segmental bearing ends 17, having a common center, and at one side of each of said bearing ends the said support is further provided with the toothed segments 18, the teeth of which project slightly beyond the surfaces of the segmental bearing ends 17. In a valve-support of this character the curved surfaces of the segmental bearing ends 17 are subjected to great and excessive wear, and therefore such surfaces at the points where they have a contact must necessarily be made as hard as it is possible to make them.

In carrying out the herein-described method the curved surfaces of the segmental bearing ends 17 have first applied thereto prussiate of potash, and the entire casting is then heated to about a cherry-red heat. After the casting has reached the desired degree of heat with prussiate of potash applied to the ends thereof the said casting is plunged into the bath of oil by dropping the same into position between the supporting-plates 3, so that the projecting teeth of the toothed segments will rest on the inner edges of the horizontal portions of said supporting-plates, which inner edges are curved to fit the segmental ends of the casting.

In the position noted the entire casting, including the teeth thereof, will be subjected to an oil-hardening, and by forcing a stream

of cold water from the jet-nipples onto the segmental bearing ends of the casting where the prussiate of potash has been previously burned in the said segmental bearing ends will receive such additional hardening as will render them capable of withstanding the severe wear to which they are subjected, particularly in locomotive and other high-speed engines.

Changes in the form, proportion, and the minor details of construction may be resorted to without departing from the principle or sacrificing any of the advantages of this invention.

Having thus described the invention, what is claimed, and desired to be secured by Letters Patent, is—

1. An improvement in the method of hardening cast steel which consists in applying prussiate of potash to certain parts of the casting to be hardened, heating the entire casting with the prussiate of potash thereon, plunging the entire heated casting into a single bath of oil, and finally forcing a stream of cold water through the oil and against the prussiate of potash coated surfaces of the casting, substantially as set forth.

2. In an apparatus for hardening cast steel, the combination of a tank adapted to contain a bath of oil, supporting plates arranged within the tank at opposite inner sides thereof, and cold water jet nipples adjustably fitted in opposite sides of the tank and projecting inwardly directly under said supporting plates, said nipples being provided with inner contracted discharge mouths, substantially as set forth.

3. In an apparatus for hardening cast steel, the combination of a tank adapted to contain a bath of oil, horizontal supporting plates arranged within the tank at diametrically opposite sides thereof and provided with inner segmentally curved edges, and a pair of upwardly extending L-shaped securing arms adapted to be fastened to the upper edges of the tank, and opposite inwardly disposed jet nipples fitted to opposite sides of the tank and arranged directly under said supporting plates, substantially as set forth.

In testimony that I claim the foregoing as my own I have hereto affixed my signature in the presence of two witnesses.

WARREN T. REASER.

Witnesses:

JOHN H. SIGGERS,
G. C. SHOEMAKER.