

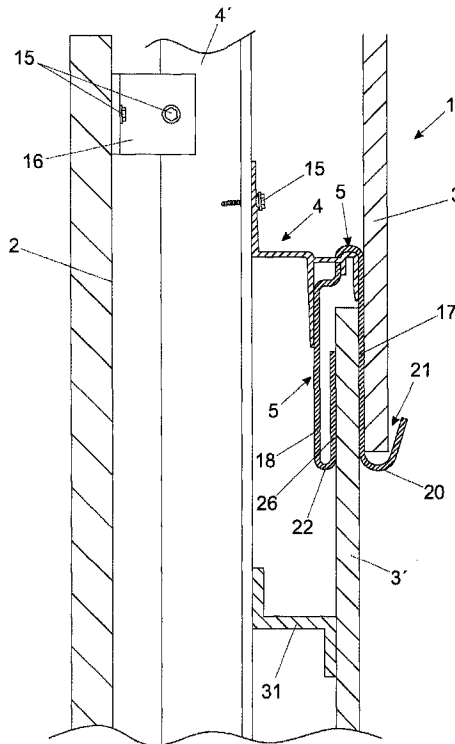

(86) Date de dépôt PCT/PCT Filing Date: 2016/04/08
 (87) Date publication PCT/PCT Publication Date: 2016/10/20
 (45) Date de délivrance/Issue Date: 2022/01/25
 (85) Entrée phase nationale/National Entry: 2017/09/13
 (86) N° demande PCT/PCT Application No.: ES 2016/070240
 (87) N° publication PCT/PCT Publication No.: 2016/166395
 (30) Priorité/Priority: 2015/04/15 (ES P201530505)

(51) Cl.Int./Int.Cl. *E04F 13/21* (2006.01),
E04F 13/08 (2006.01)
 (72) Inventeur/Inventor:
FERNANDEZ FERNANDEZ, JAVIER, ES
 (73) Propriétaire/Owner:
CUPA INNOVACION S.L.U., ES
 (74) Agent: GOWLING WLG (CANADA) LLP

(54) Titre : **FACADE VENTILEE**
 (54) Title: **VENTILATED FACADE**



(57) **Abrégé/Abstract:**

Disclosed is a ventilated façade comprising horizontal rails (4) and covering parts (3, 3') that are mounted on the horizontal rails by means of anchoring elements (5), made of wire or plate, that hang from the rails through openings (13) in a horizontal section (6) of the rails.

ABSTRACT

The invention relates to a ventilated façade comprising horizontal battens (4) and cladding parts (3-3') which are assembled on the horizontal battens by means of
5 anchoring elements (5), made of wire or sheet metal, hanging from the battens through openings (13) which said battens have in a horizontal section (6) thereof.

Figure 1.

VENTILATED FAÇADE

Field of the invention

The present invention relates to a ventilated façade, made up of cladding parts,
5 for example, slate, natural stone, ceramic or metal plates, plastic, composite panels,
cement fiber, etc., that are assembled on horizontal battens fixed on vertical battens
anchored to the wall to be cladded or directly on said wall. The assembly of the
cladding parts on the battens is carried out by means of hook anchoring elements
hanging from said battens.

10 Background of the invention

Ventilated façades are those having an air chamber between the cladding and
the wall of the façade. This air chamber creates the so-called "chimney effect",
providing continuous ventilation due to temperature differences between the outside air
and the chamber air.

15 Among ventilated façades, façades are known in which the cladding is made up
of, for example, slate parts, that are assembled by means of anchoring elements, made
of sheet metal or wire, on horizontal battens, generally made of wood, fixed to the wall
of the façade.

In this sense, patent documents CH 659679 and EP0167032 can be mentioned,
20 in which the assembly of the cladding parts is carried out by means of anchoring parts
comprising a straight section that finishes at its ends in bents heading in opposite
directions, in the form of hooks of different width. Through the hook with a larger width,
which is in an inverted position, the anchoring part hangs from the battens, and the
upper edge of a panel belonging to a lower row of panels is introduced between the
25 batten and the straight section of the anchoring part, while the lower edge of a panel
belonging to an upper row of panels is supported on the hook with a smaller width. In
patent document EP 0167032 the external branch of the hook with a larger width can
be prolonged sideways in a loop which is housed in the batten and which serves as
upward support means of the hook on said batten.

30 With this constitution, in the case of using panels of different thickness in one
and the same row, zones located in different planes appear in the visible surface of the
cladding, due to the fact that the anchoring part does not have the capacity to adjust
thicknesses.

Description of the invention

35 The present invention relates to a ventilated façade made up of a covering

which is formed by cladding parts of any type (slate, granite, plastic, sheet metal, cement fiber, etc.), which are assembled on metallic battens by means of anchoring elements made of wire or sheet metal.

5 The façade covering allows achieving a durable finish with a good visual appearance, in comparison with claddings with wooden or pre-fabricated panels.

Metallic battens offer improved performance and resistance against humidity and possible fires with respect to wooden battens.

10 The anchoring elements, made of wire, metallic rod or sheet metal, are formed such that they have greater capacity to absorb or adjust to possible differences in the thicknesses of the slate parts, which allows achieving a practically flat visible surface.

The ventilated façade of the invention is of the previously indicated type, formed by cladding parts that are assembled on horizontal battens by means of anchoring elements made of wire or sheet metal hanging from the battens through openings which said battens have.

15 According to the present invention, the anchoring elements are U-shaped and hang in an inverted position from the horizontal battens, with a rear side branch introduced through the openings of the battens, and a front side branch running downwards along the front of the batten. The aforementioned front side branch finishes in an upward bent, forming an outer hook on which there will be supported the lower
20 edge of a cladding part, belonging to an upper row of cladding parts. In turn, the rear side branch, introduced through the openings of the battens, has an inner projection establishing with the front branch of the U shape a narrowing having a width smaller than the thickness of the cladding parts. The upper edge of a cladding part belonging to a lower row of cladding parts is introduced through this narrowing.

25 The aforementioned inner projection of the rear branch of the U shape can be obtained by means of transverse formations made on said rear side branch. Furthermore, the inner projection can consist of a spring which is fixed on the inner surface of the rear side branch of the U shape.

30 With regards to the horizontal battens on which the cladding parts with an angular profile are fixed, they are made up of three sections, a central section and two end sections perpendicular to the central section and heading in opposite directions. Along the outer surface of one of the end sections these battens have a flap which is parallel to the central section of the batten. The openings are located on the aforementioned flap, through which openings the rear branch of the U shape forming
35 the anchoring elements is introduced. Furthermore this flap finishes in a longitudinal

support assuring the positioning of the anchoring elements on the batten.

The transverse formations of the rear side branch of the anchoring elements can consist of an end bent heading towards the inside of the U shape and which will define a narrowing in the mouth of said U shape, which will be elastically supported on
5 the upper edge of a cladding part introduced between said bent and the front side branch of the U shape.

Furthermore, the transverse formations of the rear side branch of the U shape can consist of intermediate bents, also heading towards the inside of the U shape, which bents forming inside the U shape an inner step which will be elastically
10 supported against the upper edge of a cladding part introduced between the mentioned intermediate bent and the front side branch of the U shape.

Brief Description of the Drawings

The features and advantages of the invention will be demonstrated based on the non-limiting embodiment shown in the attached drawings, in which:

15 Figure 1 shows a partial vertical section view of a ventilated façade formed according to the invention.

Figure 2 is the perspective view of a section of one of the battens forming part of the façade of Figure 1.

20 Figure 3 is the profile view of one of the anchoring elements of the cladding parts.

Figure 4 shows a perspective view of an anchoring element made of sheet metal.

Figures 5 to 9 show the profile views of possible variants of the anchoring element.

25 Figure 10 shows in a section view an auxiliary profile for assembling cladding parts in hard-to-reach areas.

Figure 11 shows a possible variant of the auxiliary profile of Figure 10.

Detailed Description of a Preferred Embodiment

30 Figure 1 shows in a partial vertical section view a ventilated façade formed by a covering (1), which is assembled on the wall (2) of the façade. The covering (1) is made up of parts (3-3') that are assembled in horizontal alignments on horizontal battens (4) which are fixed to vertical battens (4') anchored to the wall (2) of the façade, or directly on said wall.

The assembly of the cladding parts is carried out by means of anchoring elements (5) which hang from the battens (4). The cladding parts (3-3') can be of any type, for example, of slate, granite, plastic, metal, cement fiber, etc.

5 The battens (4), Figure 2, are of metallic type and have an angular profile made up of three consecutive sections, a central section (6) and two end sections (7 and 8) perpendicular to the central section (6) and heading in opposite directions.

10 From the end section (8), along its length, a flap (10) projects parallel and close to the section (6), the section of which ends in a longitudinal support (11) for the anchoring elements (5), in the shape of an inverted channel with walls of different height. The base (12) of this channel is approximately coplanar with the central section (6) of the batten (4).

The flap (10) has, along its length, openings (13) that will be used for hanging the anchoring elements (5).

15 Ribs (14) for positioning screws (15) for fixing the horizontal battens (4) to the vertical battens (4') run along the inner surface of the end section (7), which vertical battens (4') can be fixed to the wall by means of brackets (16) and also screws (15).

20 The anchoring elements (5'), Figures 3 to 7, have a U shape with considerably parallel branches (17 and 18). These anchoring elements hang in an inverted position from the horizontal battens (4), Figure 1, with the side branch (18), called the rear side branch, being introduced through the openings (13), while the side branch (17), called the front side branch, running along the front of the batten. In turn, the central branch (19) of the U shape has an intermediate bent, establishing sections of different depths which can be coupled on the flap (10) and support (11) of the horizontal batten.

25 The front side branch (17) finishes in an upward outer bent (20), forming a hook (21) on which there is supported the lower edge of a cladding part (3), belonging to an upper row of cladding parts.

30 The rear side branch (18) has formations which can be defined by end bents in the shape of a hook (22), Figures 3 and 4, heading towards the inside of said U shape, or in the shape of an inner tab (23), Figure 6. The mentioned formations can also be defined by intermediate bents (24-25), Figures 5 and 7.

35 In any case, the mentioned formations establish a narrowing in the inside of the U shape which will be elastically supported against the upper portion of a cladding part (3') belonging to a lower row of cladding parts partially introduced in the U shape, as shown in Figure 1. The hook (22), the tab (23) and the bents (24 and 25) establish a narrowing inside the U shape providing a spring effect compressing the cladding part

(3') against the front side branch (17) of the U shape. As a consequence, the cladding parts (3') will be pushed against the parts (3), which allows absorbing possible differences in thicknesses between cladding parts, thereby achieving in each row of cladding parts a virtually flat outer surface.

5 In the embodiment of Figure 3, the end branch (26) of the hook (22) can be provided with a cladding (27) made of an elastically compressible material or with a deformation (27'), Figure 4, to increase the aforementioned spring effect and provide improved support to the cladding parts (3').

10 The anchoring element of Figures 3 and 4 can be sub-divided in two independent parts (28 and 29), Figure 8, both in U shape, which can be hung from different openings (13) of the horizontal battens (4), through their rear side branch (18). The part (29) will be used for supporting the lower edge of cladding parts (3), through its hook (21), while the part (28) will provide, through the hook (22), the spring effect pushing the parts (3') of a lower row against the parts (3) of an upper row.

15 With the described components, for the construction of the façade of the invention, the battens (4) are thus fixed in a horizontal position on vertical battens (4') anchored to the wall (2), or directly on said wall. Next, the anchoring elements (5) are assembled by introducing the branch (18) and the hook (22) through the openings (13) of the batten (4). Once the anchoring elements are assembled, the cladding part (3) of an upper row of parts is supported on the hook (21), through the lower edge of said parts (3). At the same time, the upper edge of the cladding parts (3') belonging to a lower row of parts is introduced in the U-shape, these parts (3') being compressed between the side (26) of the hook (22), or on the cladding (27), which acts like a spring, and the branch (17) of the U shape, all according to the depiction of Figure 1.

25 The anchoring element is supported on the end section (8) of the battens (4) through the branch (18). The central branch (19) of the anchoring part has a shape which allows achieving safe seating on the batten (4).

30 By means of introducing the hook (22) of the anchoring element (5) through the opening (13), said anchoring is blocked against horizontal movements with respect to the batten.

35 The inner narrowing of the U shape, providing the aforementioned spring effect, can also be achieved by means of arranging a spring (30) fixed to the inner surface of the rear branch (18) of the U shape, Figure 8. The upper edge of a cladding part (3') belonging to a lower row of cladding parts is introduced between this spring (30) and the front branch (17) of the U shape.

Vertical chambers are demarcated between the surface of the wall (2) and the cladding elements (3-3'), which via the so-called "chimney effect", maintain continuous ventilation due to the temperature differences between the inside and outside of said chamber.

5 For improving the resistance to impact of the covering, the cladding parts can incorporate a glass fiber mesh, fixed by means of resin, for example. Intermediate support profiles (31), Figure 1, can also be installed between the cladding parts (3-3') and the vertical battens (4').

10 For assembling cladding parts in special areas of the façade, for example meeting points with windows, balconies or corners, where anchoring elements cannot be installed or where the attachment should be reinforced, auxiliary parts (32) with the profile shown in Figure 10, fixed by means of screwing them onto the batten (4), can be used. The cladding parts are introduced between the tabs (33 and 34), forming an inverted clamp (35), and may or may not be fixed with screws through the tab (33),
15 depending on the particular installation conditions of the cladding parts in each case.

Figure 11 shows, for the same purpose, an auxiliary part (36) in an inverted U shape, which is assembled on the horizontal battens in the same way as that described in reference to Figure 1, and between the branches (37 and 38) of which, forming an inverted clamp (35), there is introduced the upper edge of cladding parts (3-3') which
20 can be fixed by means of screws (39).

CLAIMS

1. A ventilated façade, comprising horizontal battens (4), cladding parts (3-3') and anchoring elements (5), the horizontal battens (4) of which have an angular profile
5 made up of three sections, a central section (6) and two end sections (7 and 8) perpendicular to the central section (6) and heading in opposite directions, and the anchoring elements of which are made of wire or sheet metal and through which the cladding parts are mounted on the battens, characterized in that:

- 10 - The horizontal battens have, along an outer surface of one of its end sections (8), a flap (10) parallel to the central section (6) of the batten, the flap of which has openings (13) from which the anchoring elements (5) hang and finishes in a longitudinal support (11) for the anchoring elements;
- 15 - The anchoring elements (5) are U-shaped and hang in an inverted position from the horizontal battens (4), with a rear side branch (18) introduced through the openings (13) of said battens, and a front side branch (17) running downwards along the front of the batten, the front side branch (17) of which finishes in an upward bent (20), forming an outer hook (21) on which there is supported a lower edge of a cladding part (3), belonging to an upper row of cladding parts, and the rear side branch (18) of which has an inner projection establishing with
20 the front branch (17) of the U shape a narrowing having a width smaller than the thickness of a cladding part (3'), through which an upper edge of said cladding part (3') belonging to a lower row of cladding parts is introduced.

2. The façade according to claim 1, characterized in that the longitudinal support (11) is configured in the shape of an inverted channel, a base (12) of which is
25 parallel and approximately coplanar with the central section (6) of the batten and walls of which are parallel to the end sections (7 and 8) of said batten.

3. The façade according to claim 1, characterized in that intermediate longitudinal ribs (14) project from an inner surface of one of the end sections of the horizontal batten (4).

30 4. The façade according to claim 1, characterized in that the inner projection of the rear branch (18) of the U shape is formed by transverse formations of said rear side branch (18).

5. The façade according to claim 4, characterized in that the transverse formations of the rear side branch (18) of the U shape consist of an end bent heading
35 towards the inside of the U shape, which defines a narrowing in the mouth of said U

shape and is elastically supported against the upper edge of a cladding part (3') introduced between said bent and the front side branch (17) of the U shape.

6. The façade according to claim 4, characterized in that the transverse formations of the rear side branch (18) of the U shape consist of intermediate bents
5 (24-25) heading towards the inside of the U shape which are elastically supported against the upper edge of a cladding part (3') introduced between said intermediate bent and the front side branch (17) of the U shape.

7. The façade according to claim 5, characterized in that the end bent of the rear
10 branch (18) of the U shape forms a hook (22) coplanar with the U shape and heading towards the inside of same, which is elastically supported against the upper edge of the cladding part (3') introduced between said hook and the front side branch (17).

8. The façade according to claim 1, characterized in that the inner projection of
15 the rear branch (18) of the U shape consists of a spring (26) which is fixed on the inner surface of said rear side branch (18).

9. The façade according to claim 1, characterized in that the anchoring elements
20 comprise two independent U-shaped parts, hanging in an inverted position from the horizontal battens, a first part (28) forming transverse formations in its rear side branch (18), and a second part (29) the front side branch (17) of which forms the outer hook (21).

10. The façade according to claim 1, characterized in that it further comprises
25 auxiliary anchoring elements (32-36) for attaching cladding parts belonging to one and the same row of parts, the auxiliary anchoring elements of which are assembled on the horizontal battens (4) and form an inverted clamp (35) for receiving the upper edge of a cladding part (3 or 3') belonging to a row of cladding parts.

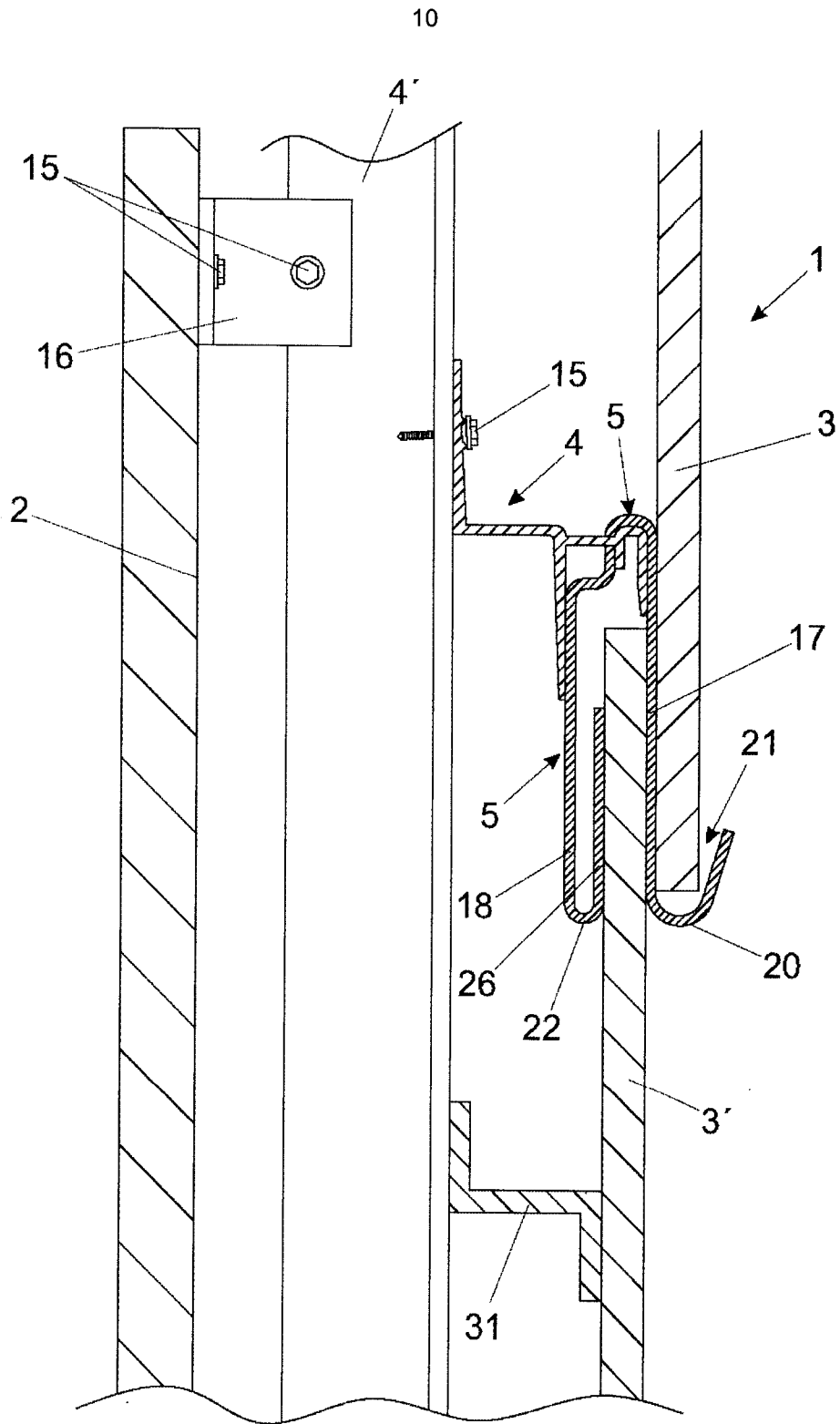

Fig. 1

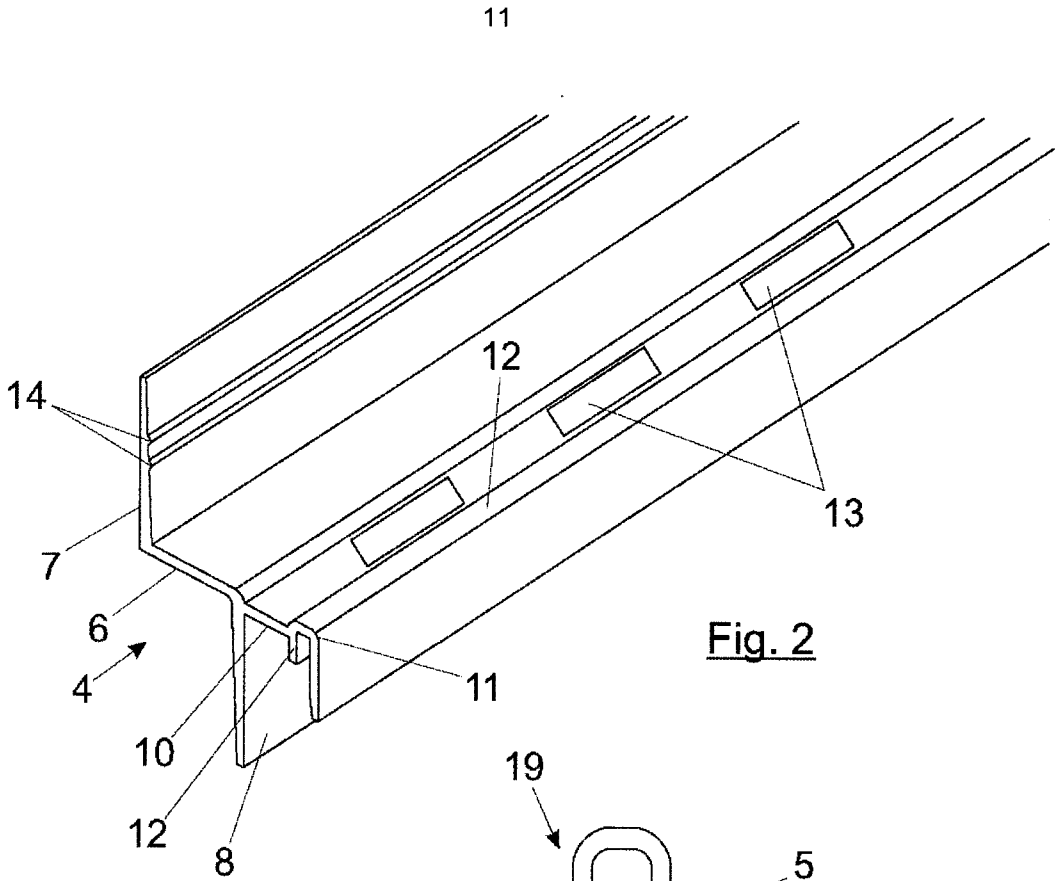

Fig. 2

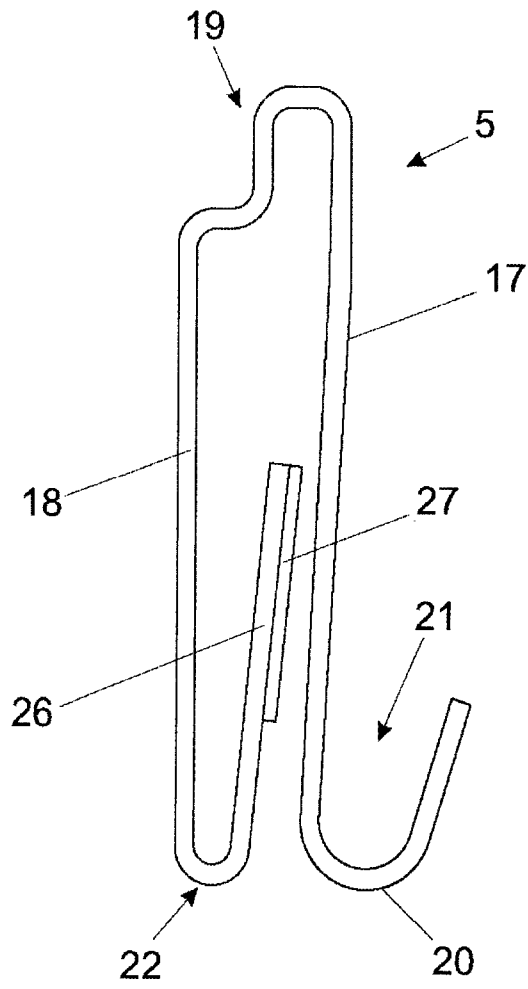
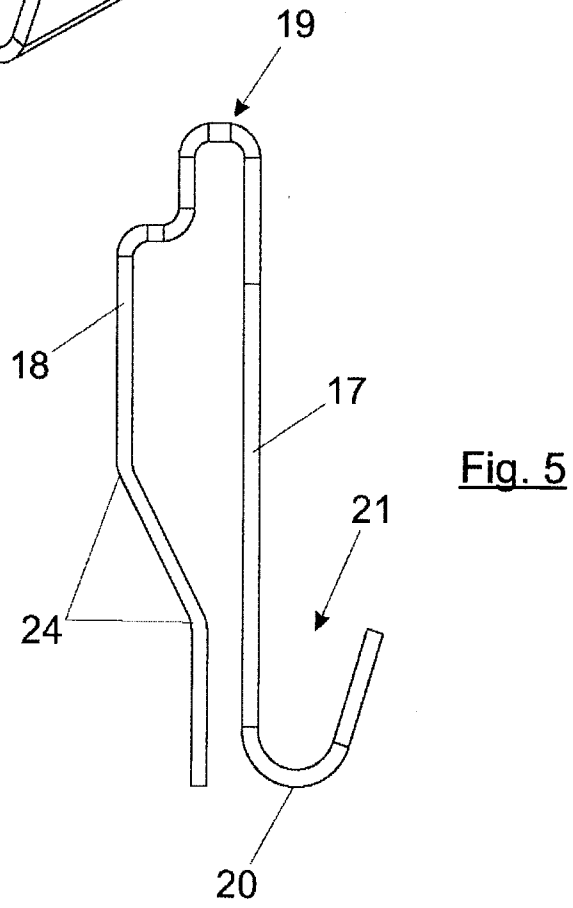
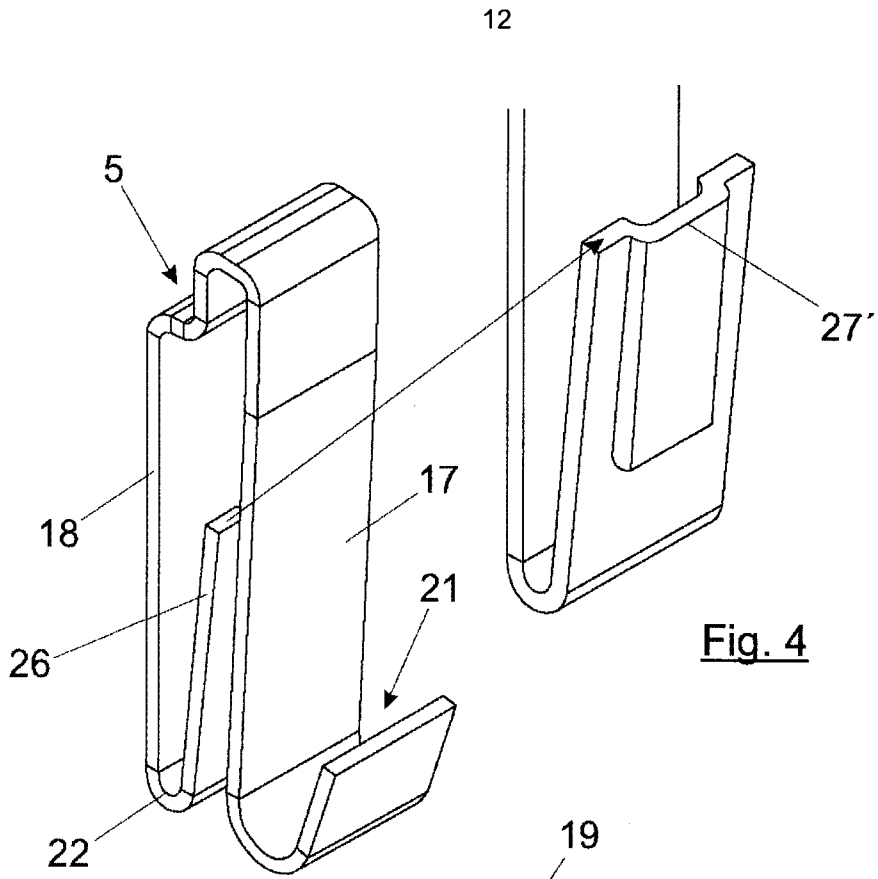
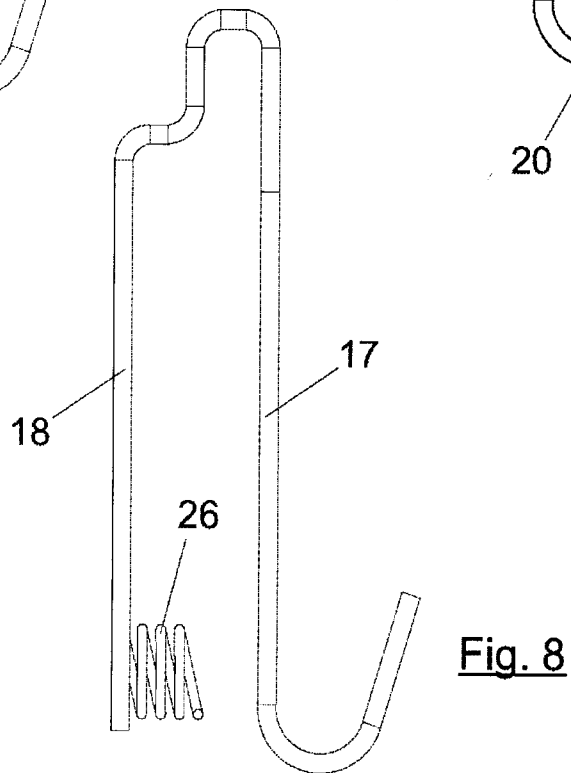
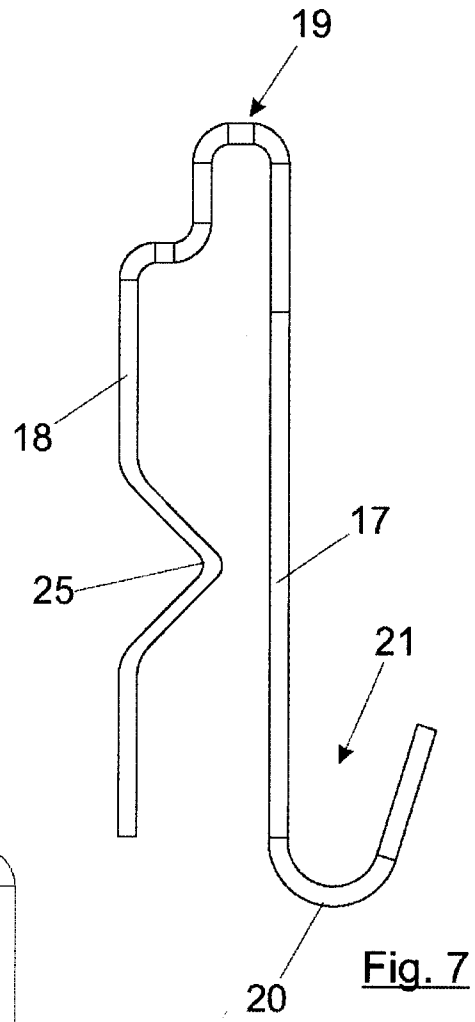
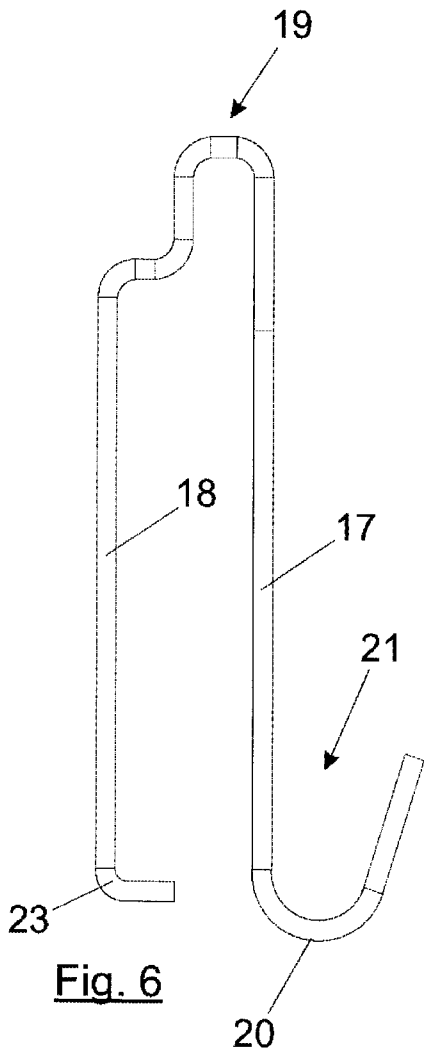

Fig. 3





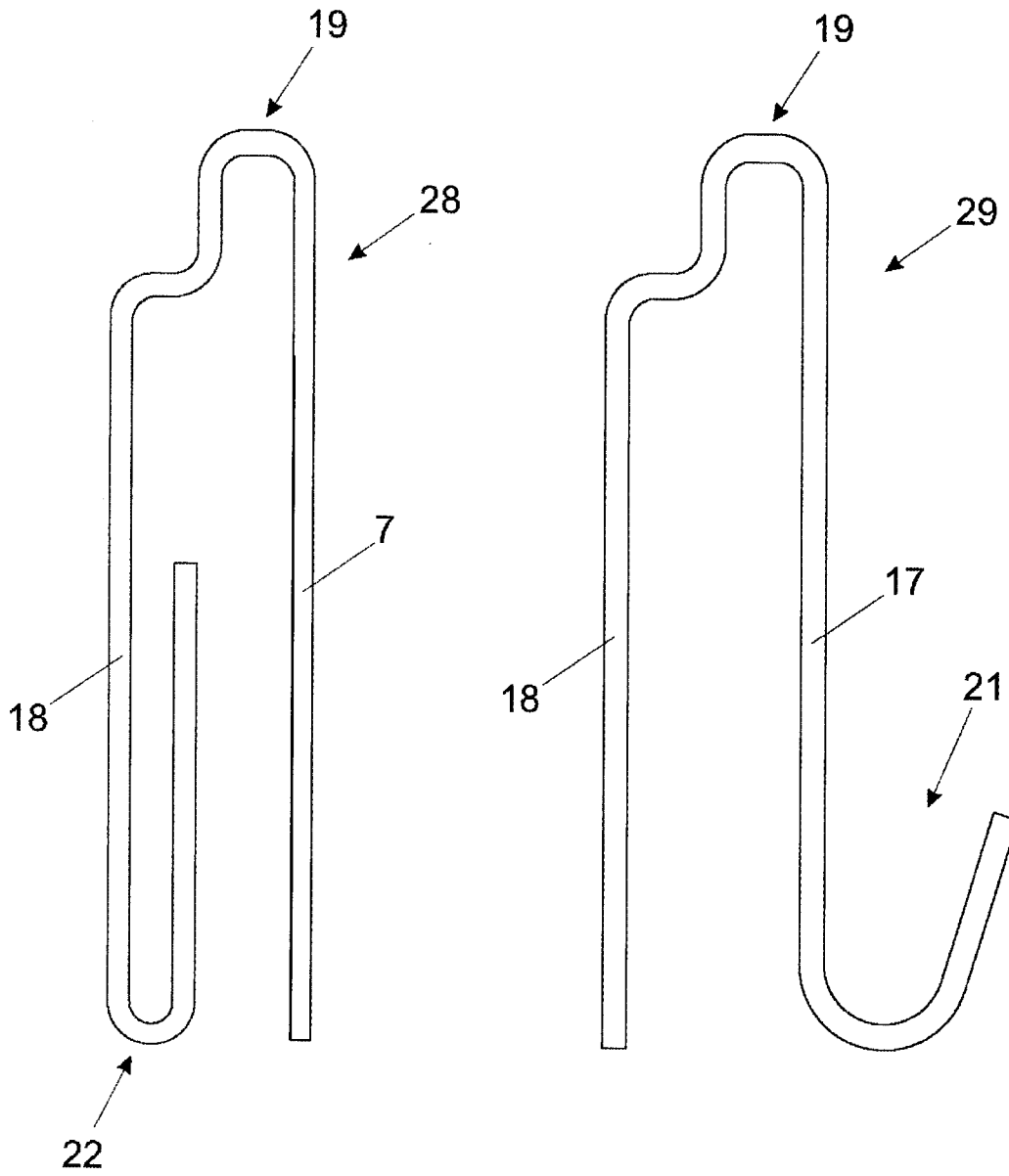

Fig. 9

15

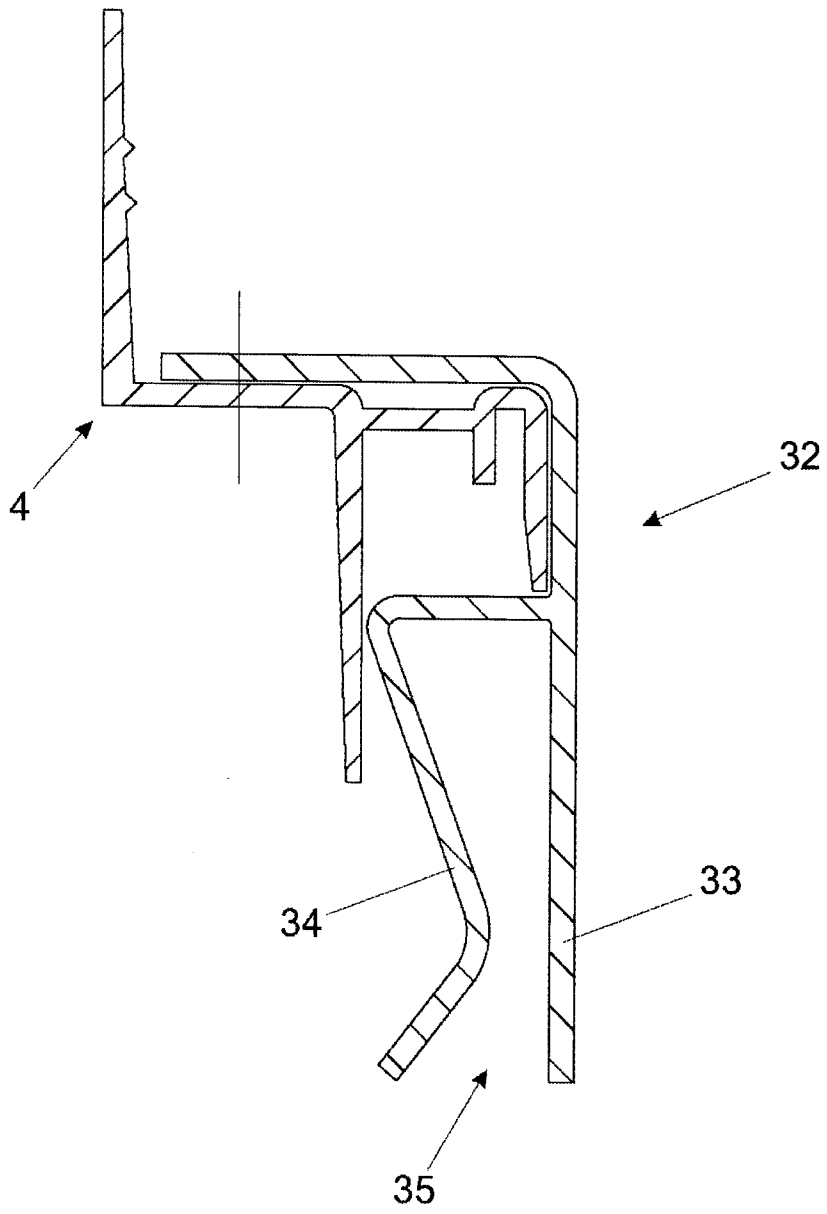

Fig. 10

16

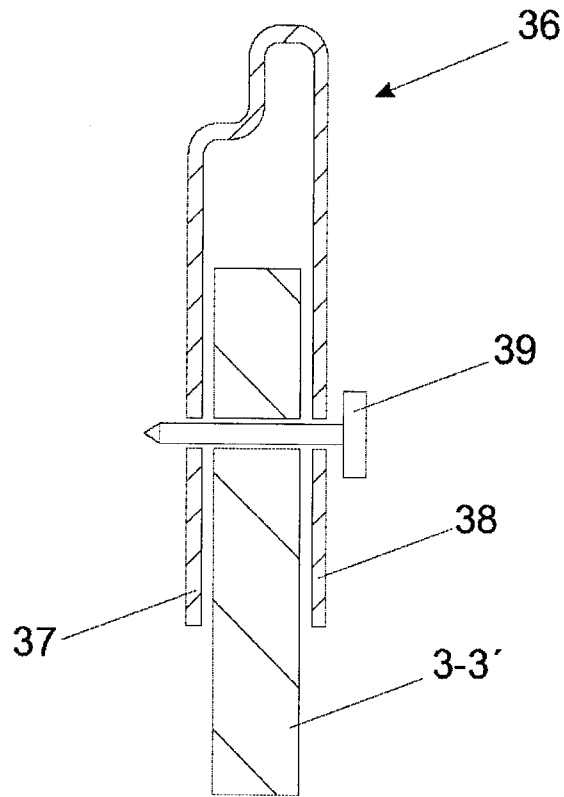

Fig. 11

