

B. CRUVELLIER.
ELECTRIC RAILWAY SYSTEM.

(Application filed May 8, 1901.)

(No Model.)

Fig 2. 3 Sheets—Sheet 1.

Fig. 1.

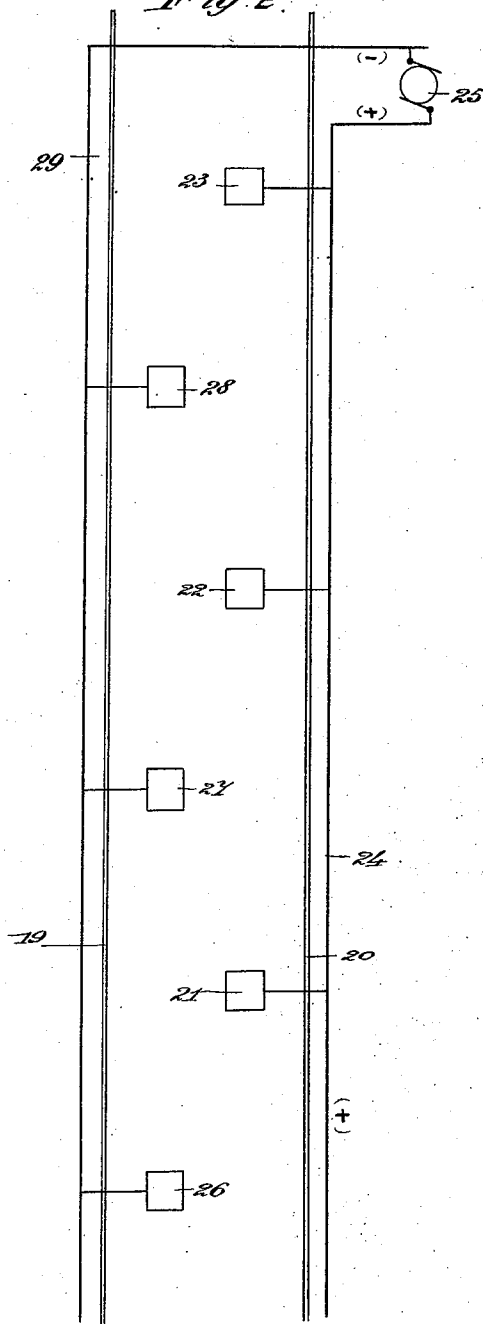
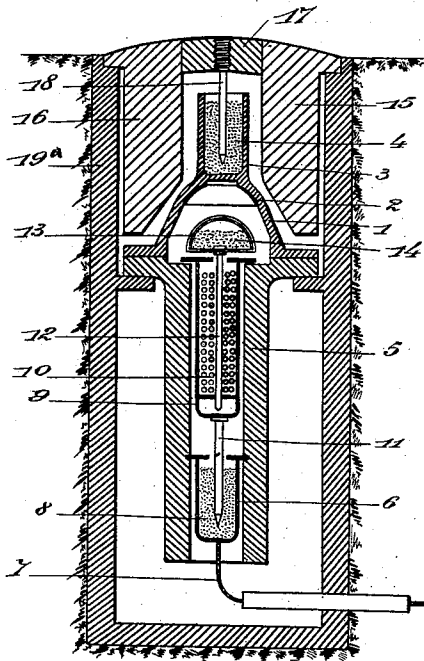

Witnesses:

J. Daney Mc Mahon.
Jacob Keller.

Inventor,
Baptistin Cruvellier.
by P. Singer
Att'y.

No. 689,706.

Patented Dec. 24, 1901.

B. CRUVELLIER.
ELECTRIC RAILWAY SYSTEM.

(Application filed May 8, 1901.)

(No Model.)

3 Sheets—Sheet 2.

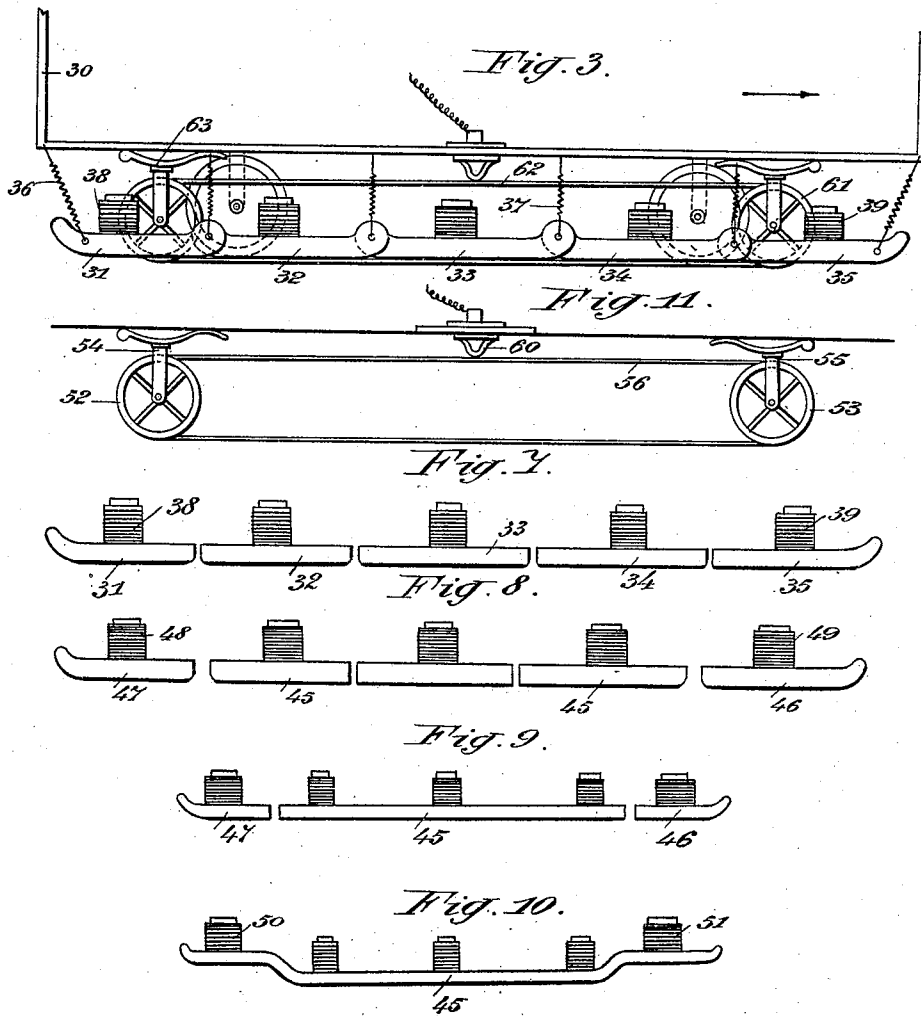

Witnesses:

J. Dancy McMahon.
Jacob Keller.

Inventor,
Baptistin Cruvellier
by P. Singer
Att'y.

No. 689,706.

Patented Dec. 24, 1901.

B. CRUVELLIER.
ELECTRIC RAILWAY SYSTEM.

(Application filed May 3, 1901.)

(No Model.)

3 Sheets—Sheet 3.

Fig. 4.

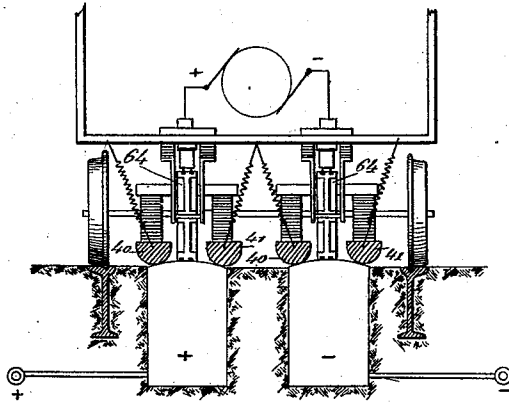

Fig. 6.

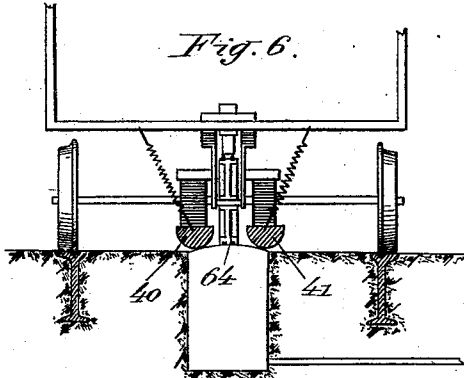

Fig. 5.



Witnesses:

J. Mary McMahon.
Jacob Heller.

Inventor,
Baptistin Cruvellier.
by P. Singer.
Att'y.

UNITED STATES PATENT OFFICE.

BAPTISTIN CRUVELLIER, OF PARIS, FRANCE.

ELECTRIC-RAILWAY SYSTEM.

SPECIFICATION forming part of Letters Patent No. 689,706, dated December 24, 1901.

Application filed May 3, 1901. Serial No. 53,601. (No model.)

To all whom it may concern:

Be it known that I, BAPTISTIN CRUVELLIER, a citizen of the French Republic, and a resident of Paris, France, have invented certain new and useful Improvements in Electric-Railway Systems, of which the following is a specification.

The present invention has for its object to provide an improved surface-contact electric-railway system.

The invention consists of the special arrangement of the contact-studs, combined with a series of magnetized bars forming the magnetic followers and one or more rotary followers serving to pick up the current.

In the accompanying drawings, Figure 1 is a sectional view of my improved contact device. Fig. 2 is a diagrammatic view showing the general arrangement of the contacts. Fig. 3 shows a follower arranged on a car. Fig. 4 shows two parallel magnetic followers. Fig. 5 shows details hereinafter referred to. Fig. 6 shows the arrangement of a single magnetic follower. Fig. 7 shows a modified arrangement of the magnetic bars. Figs. 8, 9, and 10 show further modifications of the arrangement. Fig. 11 shows a rotary follower.

Referring to the drawings, and particularly to Fig. 1, my improved contact device is essentially characterized by the manner of establishing electric communications. This I do by means of a movable rod or commutator in constant contact with and vertically movable through a mass of loose contacts—such as balls, granulated metal, filings, or the like—of conducting material connected with the source of electrical energy and drawn up through said mass by magnetic attraction from the passing car into contact with a fixed conductor exposed at the surface from which the current is then taken by appliances on said car.

1 is a casing which may be made of insulating material or of metal and containing a segmental contact 2, made integral with a metallic cup 3 of any suitable form and filled with metal filings 4 which are non-magnetic—for instance, of ferromanganese or ferronickel. The casing 1 is connected by means of an airtight joint to a receptacle 5, made of insulat-

ing material and containing in its lower part a metallic receptacle 6, directly connected with the main wire 7 and containing also metal filings 8, such as copper. The receptacle 5 contains in its upper part another metallic receptacle 9, containing balls, granulated metals, and the like 10. The lower part of said receptacle is made integral with a rod 11, dipping into the filings 8 in the receptacle 6. Passing through the balls or equivalent 10 is a rod 12, projecting at opposite ends and provided at its upper part with a hollow head 13, containing filings or the like 14. Said head is made of iron or steel and preferably provided with a cover made of non-magnetic material, such as aluminium.

15 and 16 are two magnetic iron bodies serving to conduct the magnetic flux to the point where the commutator-head 13 is arranged. Said bodies 15 and 16, which rise to the surface of the ground to form contacts, are separated by means of a non-magnetic metal piece 17, to which is secured a metallic rod 18, dipping into the filings 4, contained in the receptacle 3, and rising to the surface. The entire construction is surrounded by a receptacle 19^a, of any suitable material, such as non-magnetic cast-iron or insulating material, and tightly closed by the bodies 15 and 16 and the part 17. The lower part of the receptacle 19^a may be filled with tar or other insulating material. When a system of magnetized bars passes over the surface of said device, the flux passing through the bodies 15 and 16 will act on the commutator 13, which is raised and applied against the contact 2 by reason of the movable arrangement of the rod 12 within the balls or granulated metal 10. The main wire 7 is therefore directly connected with the surface 17 of the device through the medium of the filings 8, the rod 11, the balls 10, the rod 12, the commutator 13, the contact 2, the filings 4, and the rod 18. Therefore the current may be taken up by the follower arranged on the car. When the magnetized bars or followers are moved away from the device, the magnetic influence will be removed. The vibrations produced by the car will displace the magnetic filings 14, which instantaneously lose their magnetism and drop into the lower

part of the head 13. This will be sufficient to open the contact, while the commutator is brought back to its initial position by gravity.

My improved contact devices are essentially arranged in two series, one of which serves to conduct the positive current, while the other serves to conduct the negative current.

19 and 20, Fig. 2, are the track-rails.

21 22 23 are the positive contact devices, connected to the positive wire 24 of the dynamo 25 of the electric station.

26 27 28 are the negative contact devices, connected to the negative wire or return-wire 29 to the dynamo 25. The positive contacts are not arranged in line with the negative contacts, but reversely and eccentrically with respect to the axis of the track. The distance between the two lines of contacts is determined by the distance between followers hereinafter described.

The third main feature of my system is constituted by the magnetic follower. In order to enable the commutator 13 to remain in its raised position while the car is above the contact device, it will be necessary for the conditions between the contact device and the magnetic bars or followers to remain constant, which result is perfectly attained in my improved construction. The improved follower is essentially formed of a series of magnetic metal parts arranged in line and suspended from the car by means of a certain number of springs maintaining same at a certain distance from the ground. When the car passes over raised parts on the ground, the engaging portion of the follower will be raised thereby.

The preferred form of follower is shown in Fig. 3. 30 is a car of any preferred construction. 31 32 33 34 35 represent a series of alined bars connected by means of any suitable pivotal connection. Said bars are suspended from the car by means of springs 36 37 and support electromagnets 38 39, arranged between pivotal connections or about midway of the length of the corresponding bar. It will be understood that when the number of sections 31 to 35 is increased any desired flexibility may be obtained without affecting the transmission of electric flux. Heretofore rigid bars of rectangular cross-section have been employed for this purpose, while in my improved construction I employ bars made of rounded cross-section.

Fig. 4 shows a sectional view of a car with bar-sections 40 and 41, which may, however, be modified without departing from the scope of the invention, as indicated at 42, Fig. 5. 43 44 show other cross-sections of said bars.

When the contact devices are arranged in two lines of different sign, as shown in Fig. 2, it will be necessary to provide two parallel sets of magnetic followers, as shown in Fig. 4. This view shows also the manner in which the current passes from the positive to the negative conductor and through the motor of

the car. However, said magnetic follower may be applied to a single line of contact devices when the track-rails are employed as return-conductor to the negative pole. In this case I employ the arrangement shown in Fig. 6.

Fig. 3 of the accompanying drawings shows a system of pivotally-connected bars. Each series of bars may, however, be completely separated from the other, as shown in Fig. 7.

In the arrangements so far described the magnetic follower does not serve to take up the current, as a special rotary follower is employed for this purpose. However, when it is desired to omit the rotary follower magnetic followers may be employed to take up the current; but in this case it will be necessary to arrange at both ends thereof a small set of magnetized bars, which I will term "contact opening or closing" bars, as shown in Fig. 8. 45 is the magnetic follower. 46 47 are two sets of magnetized bars provided with strong electromagnets 48 and 49, the windings of which may run in the same or in opposite directions. The bars are insulated from the follower. Said bars serve the purpose of making the contact at the front of the car—that is, to open the passage of the electric current prior to the closing of the electric circuit effected by the take-up follower. When applied to tramway-cars, said bars serve to maintain the contact after the opening of the circuit and to permit of closing the contact only when the circuit is open. In this case the windings run in the same direction as those at the front of the car. When applied to high-speed cars, the windings of the electromagnets are arranged in opposite directions in order to open the contact by pushing same backward. The devices are applied in the construction shown in Fig. 3 by reason of the difference of length between the magnetic and electric followers.

In some cases, when it is preferred to employ followers 45 formed of single bars, Fig. 9, it will be necessary to arrange contact opening and closing bars 46 and 47 at the front and at the rear of same. In certain cases said contact opening and closing bars may constitute the only magnetic part of the follower, the central portion thereof serving to take up the current. When it is impossible to provide the car with contact opening and closing bars, the same result may be attained by suitably raising both ends of the magnetic follower serving to take up the current, as shown in Fig. 10, extending said ends, and providing same with strong electromagnets 50 and 51.

In order to enable the improved system to produce all desirable results, it is to be provided with a take-up follower reducing to nil the friction on the track and the contact devices. Fig. 11 shows a rotary take-up follower preferably formed of two or more light wheels 52 53, secured to the car by means of

any spring-fasteners 54 55. Extending around said wheels are conductors 56, formed of endless flexible wire, ribbon, chains, &c., and engaged by a brush 60, which receives the current taken by said conductors on the surface of the contact devices. The current may also be taken up by the wheels of the system or in any other manner, notwithstanding the speed imparted to the car.

10 In Fig. 3 I have shown the rotary follower 61 62 63 combined with the magnetic follower 32, 33, and 34. Fig. 4 shows the rotary follower 64 combined with the magnetic follower 40 41. When the magnetic follower is combined with the rotary follower, it may almost completely remove the electric sparks at the break of the circuit produced at the rear of each surface-contact-railway car. To this end the electromagnets 38 39, Fig. 3, are arranged so that their combination with the preceding electromagnets forms a secondary magnetic pole located underneath the rotary follower toward the point where the latter leaves the contact device—that is, where the electric spark is produced.

15 Having fully described my invention, what I claim, and desire to secure by Letters Patent, is—

1. In an electric-railway system the combination of a fixed contact exposed at the surface, a commutator or movable contact therebeneath and normally disconnected therefrom, a mass of movable contacts in which the stem of the commutator constantly dips, a connection between said mass and the source of electrical energy, and magnetic appliances upon the passing car acting to lift said commutator into electrical connection with the fixed contact.

2. In an electric-railway system, the combination of a fixed contact exposed at the surface, a metallic cup filled with non-magnetic filings into which the depending shank of said contact dips, a vertically-playing commutator having a hollow head containing filings located beneath said cup and normally out of circuit with a contact on the base thereof, a mass of movable contacts in which the shank of said commutator plays, a connection between said mass and the source of electrical energy, means for conveying magnetic flux from the surface to the commutator to lift it into electrical connection with the overhead cup, and means upon the car for inducing such magnetic flux.

3. In an electric-railway system, the combination of a fixed contact exposed at the surface, a commutator or movable contact therebeneath but normally disconnected therefrom, a mass of movable contacts in which the stem of the commutator constantly dips, a connection between said mass and the source of electrical energy, magnetic appliances upon the car acting to lift the commutator into electrical connection with the fixed contact, and

conducting appliances upon said car acting to pick up the current from the fixed contact while the commutator is so raised.

4. In an electric-railway system, the combination of two parallel series of fixed contacts of opposite sign, exposed upon the surface, a vertically-movable commutator beneath each contact but normally out of connection therewith, the commutators of one series being in constant connection with the positive pole of the dynamo, and those of the other series with the negative pole, magnetic appliances upon the car for lifting the commutators into electrical connection with the fixed contacts, and means upon the car for picking up the current from the fixed contacts and completing the circuit.

5. In an electric-railway system, the combination with a series of fixed contacts exposed at the surface, a series of commutators therebeneath and normally out of connection therewith, a series of masses of loose contacts into which the stems of the commutators constantly dip, and all in circuit with the source of electrical energy, of a series of magnetic-flux conveyers exposed at the surface alongside the fixed contacts and extending into proximity with the commutators, magnetic followers upon the car which contact with said flux-conveyers as the car passes, and thereby lift the commutators into electrical connection with the fixed contacts, and means upon said car for picking up the current from the fixed contacts.

6. In an electric-railway system the combination with a series of fixed contacts exposed at the surface, a series of commutators therebeneath and normally out of contact therewith, a series of masses of loose contacts into which the stems of the commutators dip, and all in circuit with the source of electrical supply, of a series of fixed magnetic-flux conveyers exposed at the surface alongside said fixed contacts and extending into proximity with the commutators, a series of self-adjusting magnetic followers upon the car, arranged to come successively into contact with said flux-conveyers to lift the commutators into electrical connection with said fixed contacts, and a rotary conducting-follower arranged upon the car to pick up the current from the fixed contacts.

7. In an electric-railway system, the combination with a series of fixed contacts exposed upon the surface, and masses of non-magnetic loose metallic contacts into which their stems dip, of underlying commutators normally out of electrical connection with said fixed contacts but in constant circuit with the source of electrical energy, magnetic appliances upon the car for lifting said commutators into electrical connection with the fixed contacts, and means upon the car for picking up the current from said fixed contacts.

8. The combination of the casing 1, contact 130

2 with its metallic cup 3 filled with non-magnetic metal filings, the fixed contact with its stem dipping into said filings, the vertically-moving commutator, the magnetic-flux conveyers, the metallic receptacle 9 filled with loose contacts in which the stem of the commutator constantly dips, and the metallic receptacle 6 connected with the main wire and

filled with metallic filings into which a rod 11 from receptacle 9 dips. 10

In testimony whereof I have hereunto set my hand in presence of two witnesses.

BAPTISTIN CRUVELLIER.

Witnesses:

ADOLPHE STURM,
EDWARD P. MACLEAN.