



(12) **DEMANDE DE BREVET CANADIEN
CANADIAN PATENT APPLICATION**

(13) **A1**

(22) Date de dépôt/Filing Date: 2017/07/06
(41) Mise à la disp. pub./Open to Public Insp.: 2019/01/06

(51) Cl.Int./Int.Cl. *C10G 1/00* (2006.01)
(71) Demandeur/Applicant:
CELLUFUEL INC., CA
(72) Inventeur/Inventor:
MILOSEVIC, VESELIN, CA
(74) Agent: ROBIC

(54) Titre : PRODUCTION DE DIESEL A PARTIR DE BIOMASSE CELLULOSIQUE
(54) Title: PRODUCTION OF DIESEL FROM CELLULOSIC BIOMASS

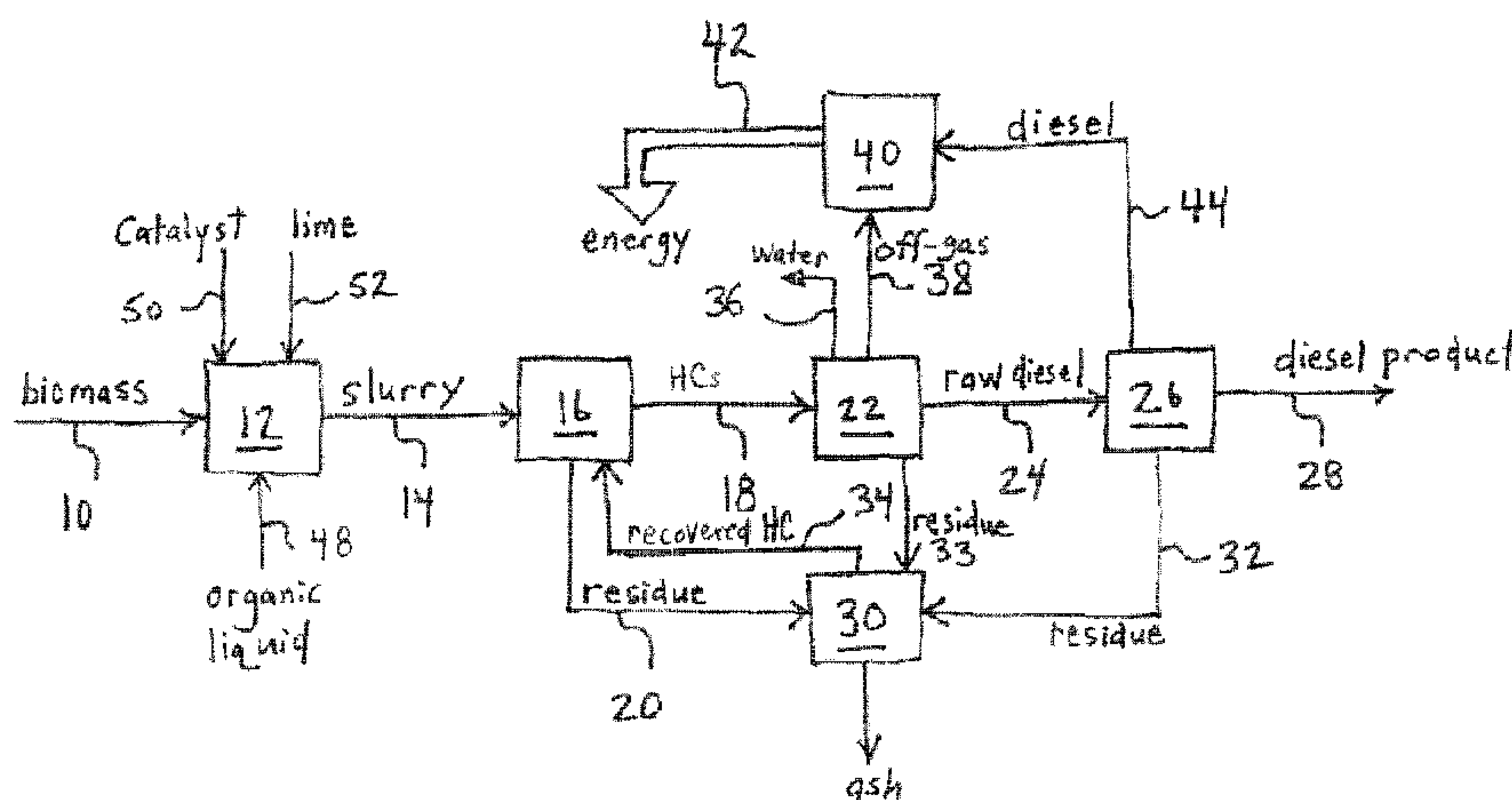

(57) **Abrégé/Abstract:**

Processes for producing diesel from biomass can include supplying cellulosic biomass to a solubilization unit to form an organic slurry, which is transferred to a depolymerization unit to produce a treated hydrocarbon stream that is separated into an upper gaseous hydrocarbon stream and a bottom slurry phase in a phase separator. The gaseous hydrocarbon stream can then be purified via distillation to produce a diesel stream. The bottom slurry phase of the separator can be sent to a residuals treatment unit to recover hydrocarbons which can be recycled back into the solubilization unit. The bottom slurry phase can be withdrawn and recirculated back into the phase separator to inhibit deposition and plugging. The biomass can be fed as a particulate material into the solubilization unit via a feed screw below the liquid. The biomass slurry can also be fed to the depolymerization unit to inhibit back-heating and back flow.

ABSTRACT

Processes for producing diesel from biomass can include supplying cellulosic biomass to a solubilization unit to form an organic slurry, which is transferred to a depolymerization unit to produce a treated hydrocarbon stream that is separated into an upper gaseous hydrocarbon stream and a bottom slurry phase in a phase separator. The gaseous hydrocarbon stream can then be purified via distillation to produce a diesel stream. The bottom slurry phase of the separator can be sent to a residuals treatment unit to recover hydrocarbons which can be recycled back into the solubilization unit. The bottom slurry phase can be withdrawn and recirculated back into the phase separator to inhibit deposition and plugging. The biomass can be fed as a particulate material into the solubilization unit via a feed screw below the liquid. The biomass slurry can also be fed to the depolymerization unit to inhibit back-heating and back flow.

PRODUCTION OF DIESEL FROM CELLULOSIC BIOMASS

TECHNICAL FIELD

The technical field generally relates to the production of hydrocarbon fuel from biomass, and more particularly to the production of a hydrocarbon product, such as diesel, from cellulosic biomass.

BACKGROUND

The conversion of biomass, particularly cellulosic and woody biomass, to various forms of liquid fuel has been achieved via various conventional pathways. Pyrolysis, gasification, catalytic conversion and fermentation are some leading pathway platforms that have been developed. One challenge has been to evolve and encapsulate those pathways into long-term viable businesses. Consequently, the development of the next-generation biofuels industry has been relatively limited.

Another challenge is that the overall economic viability of various known technology platforms is a function of many other business and economic dynamics. The history of biofuel development is littered with examples of technology pathways that were pursued for certain technical merits, but key business dynamics, such as a long-term sustainable source of raw materials at assumed prices, were not properly accounted for.

Indeed, there are a number of challenges with respect to identifying and implementing reliable and efficient technologies for the conversion of biomass into liquid fuel.

SUMMARY

In some implementations, there is provided a process for producing diesel from biomass, comprising: supplying cellulosic biomass to a solubilization unit to form an organic slurry comprising solubilized carbonaceous material, wherein the cellulosic biomass is supplied in particulate form via a plug screw feeder into the solubilization unit; supplying the organic slurry to a depolymerization unit to depolymerize carbonaceous polymers contained in the organic slurry and produce a treated hydrocarbon stream; supplying the treated hydrocarbon stream to a phase separator to produce at least an upper gaseous hydrocarbon stream and a bottom slurry phase; and supplying the gaseous hydrocarbon stream to a purification unit to produce a diesel stream.

In some implementations, the cellulosic biomass comprises sawdust from wood processing. In some implementations, the cellulosic biomass supplied to the solubilization unit has particle sizes of at most 3 mm. The cellulosic biomass supplied to the solubilization unit can have particle sizes between 1 mm and 3 mm. The cellulosic biomass can be subjected to pre-grinding to obtain the particle sizes.

In some implementations, the cellulosic biomass is subjected to pre-drying so as to have a moisture content of about 5 wt% to about 15 wt prior to supply into the solubilization unit.

In some implementations, the cellulosic biomass is supplied into the solubilization unit below a liquid level of the organic slurry therein. In some implementations, the solubilization unit comprises an internal mixer operable to mix the organic slurry and promote solubilization.

In some implementations, the process further comprises recycling a portion of the bottom slurry phase back into the depolymerization unit.

In some implementations, the process further comprises supplying at least a portion of the bottom slurry phase from the phase separator to a residuals treatment unit to produce a recovered hydrocarbon gas and a solids enriched bottom fraction; condensing the recovered hydrocarbon gas to produce a recovered hydrocarbon liquid; recycling at least a portion of the recovered hydrocarbon liquid back into the solubilization unit to form part of the organic slurry.

In some implementations, there is provided a process for producing diesel from biomass, comprising: supplying cellulosic biomass to a solubilization unit to form an organic slurry comprising solubilized carbonaceous material, wherein the cellulosic biomass is supplied in particulate form below a liquid level of the organic slurry in the solubilization unit; supplying the organic slurry to a depolymerization unit to depolymerize carbonaceous polymers contained in the organic slurry and produce a treated hydrocarbon stream; supplying the treated hydrocarbon stream to a phase separator to produce at least an upper gaseous hydrocarbon stream and a bottom slurry phase; recycling a portion of the bottom slurry phase back into the depolymerization unit; and purifying the gaseous hydrocarbon stream to produce a diesel stream.

In some implementations, process for producing diesel from biomass, comprising: supplying cellulosic biomass to a solubilization unit to form an organic slurry comprising solubilized carbonaceous material, wherein the solubilization unit is operated at a solubilization temperature between 160°C and about 200°C, for example; supplying the organic slurry to a depolymerization unit to depolymerize carbonaceous polymers contained in the organic slurry and produce a treated hydrocarbon stream, wherein the depolymerization unit is operated at a depolymerization temperature above that of the solubilization unit, for example between 260°C and about 300°C; operating a fluid transfer system to supply the organic from the solubilization unit to the depolymerization unit such that back-flow and back-heating from the depolymerization unit toward the solubilization unit are inhibited; supplying the treated hydrocarbon stream to a phase separator to produce at least an upper gaseous hydrocarbon stream and a bottom slurry phase; and purifying the gaseous hydrocarbon stream to produce a diesel stream.

In some implementations, the fluid transfer system comprising an outlet line for withdrawing the organic slurry from the solubilization unit, at least one pump coupled to the outlet line for receiving the organic slurry therefrom and pumping the organic slurry downstream, and a downstream line coupled to the pump for receiving the organic slurry therefrom and supplying the organic slurry into the depolymerization unit.

In some implementations, the process includes measuring at least one process variable, and adjusting the pump based on the measured process variable.

In some implementations, a slurry temperature of the organic slurry is measured in the solubilization unit, the outlet line and/or the downstream line, and the pump is controlled to regulate transfer of the organic slurry in order to maintain the slurry temperature below a pre-determined threshold.

In some implementations, the pump is controlled to increase the flow rate of the organic slurry from the solubilization unit to the depolymerization unit in response to a measured back-heating of the organic slurry upstream of the depolymerization unit.

In some implementations, the pump is controlled to increase the flow rate of the organic slurry from the solubilization unit to the depolymerization unit in response to a measured viscosity reduction of the organic slurry upstream of the depolymerization unit.

In some implementations, the process includes recycling a portion of the bottom slurry phase back into the depolymerization unit. In some implementations, the recycled portion of the bottom slurry phase is fed back into the downstream line upstream of the depolymerization unit.

In some implementations, process for producing diesel from biomass, comprising: supplying cellulosic biomass to a solubilization unit to form an organic slurry comprising solubilized carbonaceous material; supplying the organic slurry to a depolymerization unit to depolymerize carbonaceous polymers contained in the organic slurry and produce a treated hydrocarbon stream; supplying the treated hydrocarbon stream to a phase separator to produce at least an upper gaseous hydrocarbon stream and a bottom slurry phase comprising liquid hydrocarbons and solid particulate material; withdrawing an underflow stream comprising the bottom slurry phase from the phase separator; recirculating at least a portion of the underflow stream as a recirculated stream back into the phase separator to provide agitation of the bottom slurry phase within the phase separator to inhibit deposition on the inner walls of the phase separator; and purifying the gaseous hydrocarbon stream to produce a diesel stream.

In some implementations, the recirculating comprises pumping the recirculated stream back into the phase separator below a liquid level therein. In some implementations, the recirculating comprises feeding the recirculated stream back into the phase separator via a single inlet. In some implementations, the recirculating comprises feeding the recirculated stream back into the phase separator via at least two inlets. In some implementations, the at least two inlets are each located at different heights of the phase separator. In some implementations, the at least two inlets are each located at different locations around the periphery of the phase separator.

In some implementations, a first portion of the underflow stream is recirculated as the recirculated stream, and a second portion of the underflow stream is supplied to a downstream unit. In some implementations, the second portion of the underflow stream is supplied to a residuals treatment unit to produce a recovered hydrocarbon gas and a solids enriched bottom fraction.

In some implementations, the recirculating is controlled to vary a recirculation flow rate in response to a measured process variable. The recirculating can be operated

continuously or periodically. In some implementations, the recirculating is performed such that the recirculated stream is fed into the bottom slurry phase at a fixed location and feed direction.

In some implementations, there is provided a process for producing diesel from biomass, comprising: supplying cellulosic biomass to a solubilization unit to form an organic slurry comprising solubilized carbonaceous material; supplying the organic slurry to a depolymerization unit to depolymerize carbonaceous polymers contained in the organic slurry and produce a treated hydrocarbon stream; supplying the treated hydrocarbon stream to a phase separator to produce at least an upper gaseous hydrocarbon stream and a bottom slurry phase comprising liquid hydrocarbons and solid particulate material; supplying the gaseous hydrocarbon stream to a purification unit to produce a diesel stream; supplying at least a portion of the bottom slurry phase to a residuals treatment unit to produce a recovered hydrocarbon stream and a solids enriched bottom fraction; and recycling the recovered hydrocarbon stream back into the solubilization unit to form part of the organic slurry.

In some implementations, the recovered hydrocarbon stream withdrawn from the residuals treatment unit is a recovered hydrocarbon gas, and the process further comprises condensing the recovered hydrocarbon gas to produce a recovered hydrocarbon liquid; and recycling the recovered hydrocarbon liquid back into the solubilization unit to form part of the organic slurry.

In some implementations, the recovered hydrocarbon liquid is fed into the solubilization unit below a liquid level therein. In some implementations, the recovered hydrocarbon liquid is fed into the solubilization unit below a biomass feed inlet thereto. In some implementations, the recovered hydrocarbon liquid is supplied to a feed tank, and then pumped from the feed tank into the solubilization unit.

In some implementations, supply of the recovered hydrocarbon liquid is controlled based on a measured process variable of the solubilization unit. In some implementations, the measured process variable comprises slurry temperature of the organic slurry in the solubilization unit, and the supply of the recovered hydrocarbon liquid is controlled in accordance with the slurry temperature. In some implementations, the measured process variable comprises torque of a mixer deployed in the solubilization unit to mix

the organic slurry, and the supply of the recovered hydrocarbon liquid is controlled in accordance with the mixer torque. In some implementations, supply of the recovered hydrocarbon liquid is increased in response to the measure torque exceeding a pre-determined threshold value. In some implementations, supply of the recovered hydrocarbon liquid is controlled to maintain a generally constant viscosity and/or torque in the solubilization unit.

In some implementations, the residuals treatment unit comprises a kiln or furnace operated at temperatures between 400°C and 450°C.

It should be noted that various features (such as operating parameters, chemical addition, process configuration, and so on) can be used in the above-mentioned implementations of the processes, and some of such features are further described herein. Other carbonaceous feedstocks can be used instead of biomass, and various alternative process configurations can also be used. It should also be noted that intervening unit operations can be conducted in between two unit operations mentioned above (e.g., in between solubilization and depolymerization there can be a heating step, in between phase separation and purification there can be various other cooling and separating steps, and so on). In addition, systems can also be provided to implement the processes described herein, and may include a solubilization unit, a depolymerization unit, a phase separator, a purification unit, a residuals treatment unit, as well as various other components for interconnecting and managing the units and for facilitating the overall operation.

BRIEF DESCRIPTION OF THE DRAWINGS

Fig 1 is a block diagram of a process for the conversion of biomass into diesel fuel.

Fig 2 is another more detailed block diagram for an example process for the conversion of biomass into diesel fuel.

Fig 3 is a side view schematic of a solubilization unit.

DETAILED DESCRIPTION

Referring to Fig 1, which is a high-level diagram of an example process for producing diesel from biomass, there are several unit operations that facilitate the conversion and

handling of various streams. In general, biomass 10 is first supplied to a solubilization unit 12 to produce a solubilized biomass containing stream 14 (also referred to as a hydrocarbon rich slurry or biomass slurry), which is then supplied to a depolymerization unit 16 to produce a diesel containing stream 18 (also referred to as output hydrocarbon stream) and a residue stream 20. The diesel containing stream 18 is supplied to a separator 22 to produce a raw diesel stream 24, which is then sent to a purification unit 26 to produce a more refined diesel product 28.

In addition, the residue stream 20 from the depolymerization unit 16 can be supplied to a residuals treatment unit 30. Also, additional residues 32, such as viscous sludges, which may be generated in the purification unit 26 can also be supplied to the residuals treatment unit 30. Other residues 33 withdrawn from the separator 22 can also be supplied to the treatment unit 30. The residuals treatment unit 30 can be operated to produce a recovered organics stream 34, which can be fed back to the depolymerization unit 16 or sent to other processing units.

Furthermore, the separator 22 produces the raw diesel stream 24 in addition to a water stream 36 and an off-gas stream 38 that can be supplied to a generator unit 40 to generate power 42 that is used in the system. The generator unit 40 can also receive a portion of raw and/or refined diesel as a diesel-based fuel stream 44 for power generation.

As will be explained in further detail below, there are various techniques for conducting the unit operations and handling the streams generated in the process.

Biomass and carbonaceous feedstock materials

The biomass that is converted into diesel can be from various sources. In some implementations, the biomass is cellulosic biomass, and more particularly wood biomass. The wood biomass can be or include a low-value woody biomass material.

Prior to supplying raw biomass to the solubilization unit, the biomass can be subjected to various pre-treatments, such as drying and size-reduction, in order to facilitate subsequent processing. In some implementations, the biomass is prepared to take the form of a fine particulate material (e.g., course wood flour), where the particle sizes can preferably be below about 3 mm, e.g., ranging between about 1 mm and about 3 mm.

Larger particles can be used, although solids and slurry handling issues are reduced and solubilization is enhanced with smaller sized particles. It was found, for example, that particles of about 5 mm were not as advantageous as particles ground to 3 mm or smaller. The raw biomass can be pre-dried and then subjected to grinding to produce the particulate cellulosic material that is supplied into the solubilization unit.

Conversion of low-value woody biomass into high-value sustainable diesel products facilitates efficient use of such raw materials. The wood based material can be obtained from the forestry sector and its value chain participants, which are in need throughout many regions of Canada and elsewhere of a technology as described herein. The processes and systems described herein can facilitate primary forestry activities to be more economic and for secondary activities to have a market for their residuals.

The wood based biomass can include sawdust from wood processing, bark and other woody materials, residual streams from the forestry or pulp-and-paper industries, and so on. In addition, the biomass that is used as the feedstock can include various cellulosic sources, including fuel crops, agriculture residues, some municipal solid waste materials, and so on. It is also noted that various carbonaceous feedstocks and combinations of carbonaceous feedstocks can be used in processes and systems described herein, and while biomass derived sources are preferred it is also possible to use other carbonaceous materials (e.g., materials that include carbon-based polymers and/or sugars) as feedstocks. In addition, the source of carbonaceous material can change over time, such that a first material or combination of materials can be used during start-up and ramp up stages, while a second material or combination of materials can be used during steady state operations, for example.

In terms of the pre-drying, in some implementations the biomass (e.g., wood biomass) is dried to a moisture content of at most about 15 wt%, for example, or between about 5 wt% and about 15 wt%. The pre-drying can be performed in a dryer (D in Fig 2), which can be located on-site with the rest of the processing units, or can be located at a remote location (e.g., saw mill). Preferably, the wood is in the form of wood chips or smaller particulates when subjected to the pre-drying step, to accelerate and enhance the drying step. The wood is preferably pre-dried prior to the size-reduction step to produce the particulate biomass that is fed into the solubilization unit.

In terms of the grinding of the biomass, in some implementations the biomass is pre-ground just before being fed into the solubilization unit in order to avoid substantial moisture reabsorption. For example, the dried biomass can be fed into a grinding unit (G in Fig 2), located proximate to a hopper or other feed unit into which the ground particulate biomass is supplied. From the feed unit, the ground particulate biomass can be fed directly into the solubilization unit. The grinder G can be operable for variable size reduction and/or variable grinding rates to handle different feed rate demands, different biomass types, and other variables. The grinding can be adapted to factors in the solubilization unit, e.g., finer grinding to promote faster or more complete solubilization, if needed at certain operating conditions.

Solubilization

Referring to Fig 2, the solubilization unit 12 receives the biomass feed material 10, which has preferably been pre-treated so as to have a moisture content of about 5 wt% to about 15 wt%, and a size of about 1 mm to about 3 mm. The solubilization unit 12 preferably comprises a solubilization vessel 46 that can be configured as a mixing reactor having a mixing element 47 extending into the reaction chamber. The mixing element 47 can include an impeller-type mixer or another type of reactor mixer.

The solubilization unit 12 also receives an organic liquid into which the biomass dissolves, and chemical agents to enhance the process. The organic liquid can be a medium or high-temperature carrier oil 48. The carrier oil 48 used in the process can be a high-performance mineral oil with a boiling temperature above about 370°C. In some implementations, the carrier oil 48 can be used to help dissolve the biomass and create the hydrocarbon rich slurry. The carrier oil 48 can be used primarily or exclusively at start-up, and it can be re-circulated throughout the system such that, over time, it is gradually displaced by a recycled heavier oil fraction produced by the process, while it is in part broken into diesel and in part ends with the heavy bottom residue in the phase separator. In some implementations, the process does not require constant addition of the carrier oil 48 and can be mainly used during start-up situations. However, carrier oil 48 can be used as a top-up fluid if necessary. The carrier oil 48 can be added via a distinct line into the solubilization vessel 46 or the same line as the recycled heavier oil stream.

Regarding the chemical agents, a catalyst 50 and a pH control agent 52 can be added to provide appropriate conditions for dissolution and depolymerization. The pH control agent 52, such as lime, can be added to support the solubilizing process into the organic liquid. Lime can be used to control the pH of the process mixture to about 8.5 to about 9.5, or about 9, as this pH level favors the depolymerization of biomass to linear and saturated hydrocarbons as well as to precipitate any metals and sulphur found in the process medium. Lime can be added to the system at about 1.5% to about 4% (w/w) based on the biomass input, for example. The pH control agent 52 can also be added into the solubilization vessel 46 and/or at other locations in the process.

The catalyst 50, which can be a sodium-aluminum silicate type catalyst, can be added for lowering the activation energy of depolymerization and allows for the depolymerization of biomass at lower temperatures. Catalyst 50 can be added to the system at 0.25% to 3% (w/w) based on the biomass input, for example. Catalyst can be added at various locations in the process, such as directly into the solubilization vessel 46, in-line in between the solubilization vessel 46 and the depolymerization unit 16 or the separator 22, into the recycle line that feeds into the solubilization vessel 46 or an upstream tank or mixer, and/or directly into the separator 22, for example. Preferably, the catalyst is added into the solubilization vessel 46 to enable it to begin reactions early on in the process and to enhance mixing with the slurry. In addition, both lime 52 and catalyst 50 can contribute to the formation of hydrogen radicals from the biomass, which are suitable for making saturated hydrocarbons through molecular recombination and positively influence the stability of the diesel product.

It should be noted here that the catalyst 50 and the pH control agent 52, as well as other chemical agents, can be added in various ways and at various stages of the overall process. In one implementation, the catalyst 50 and the pH control agent 52 are both added into the solubilization vessel 46 such that the resulting mixture in the solubilization vessel 46 includes the biomass, the organic liquid, the catalyst 50 and the pH control agent 52. Alternatively, in some other implementations, the catalyst 50 may be added into the solubilized biomass containing stream 14 that is withdrawn from the solubilization vessel 46, prior to introduction into the depolymerization unit 16. The chemical agents can also be added in various forms (e.g., solid, dispersed in carrier fluid, and so on).

In some implementations, the solubilization vessel 46 enables mixing of the contents while being kept under temperature and pressure conditions that favour evaporation of water, solubilization of the biomass into the organic liquid, and efficient operation and energy use. The solubilization vessel 46 can be operated at temperatures between, for example, about 160°C and about 200°C, about 170°C and about 190°C, about 175°C and about 185°C, or about 180°C, or another temperature that is provided based on the operating pressures. The pressure in the solubilization vessel 46 can be above, at or below atmospheric pressure. In one example, the solubilization vessel 46 is operated at vacuum pressure conditions. The temperature and pressure conditions can also be provided to facilitate extraction and vaporization of existing moisture out of the biomass and for the creation of the hydrocarbon rich slurry (also referred to as the solubilized biomass containing stream). Water is released from the input biomass quickly, which is facilitated by mixing the contents of the vessel 46, and the water vapour is recovered via a condenser column 54 mounted on top of the solubilization vessel 46. Water can then be collected in a recovery tank 55, preferably after being cooled. In some implementations, the residence time in the solubilization vessel 46 is between about 30 minutes and about 45 minutes. It is also noted that some water remains in the biomass slurry 14 that is withdrawn from the solubilization unit 12, and is involved in subsequent reactions.

Referring to Figs 2 and 3, the solubilization unit 12 includes a biomass feed system 56 that can advantageously include a feed screw 58 for feeding the particulate biomass into the solubilization vessel 46. The feed screw 56 can have various constructions and arrangements. For example, the feed screw 56 can be arranged at an oblique downward angle, and its downstream end can be fluidly coupled to the reaction chamber via the lower part of a side wall of the solubilization vessel 46.

In some implementations, the biomass feed system (e.g., feed screw 56) is arranged to feed the biomass below the liquid level of the organic liquid in the solubilization vessel 46, which can facilitate effective mixing, reduce accumulation of biomass (e.g., at the top of the vessel), and reduce entrainment of biomass as a fine dust via overhead systems or vacuum line when vacuum pressures are implemented, thereby inhibiting solids plugging of column/condenser trays over time. Feeding the particulate biomass into the solubilization vessel 46 underneath the liquid level in the vessel is preferably done by using a plug feed screw, which compresses the particulate biomass in a short path and

pushes it into the vessel where it is dissolved. This biomass feeding arrangement can also enhance safety by compressing air out of the biomass material, which prevents potential issues when the biomass input touches the hot organic liquid in the vessel. This biomass feeding arrangement also reduces or eliminates issues with fine biomass dust going into the overhead column, since the mixing action in the vessel enables the biomass to be quickly dissolved/dispersed into the hot oil and substantially prevents anything except water vapour and light hydrocarbon vapours to travel out of the liquid medium.

Thus, in some implementations, the biomass feeding system is configured and operated to receive an air-containing particular biomass material, and compress air out of the biomass material during feeding so that the compressed biomass fed into the reactor is depleted in air upon contact with the hot organic liquid. Preferably, the biomass feeding system is arranged to feed the preferably compressed biomass into the solubilization vessel 46 below the liquid level. Such feeding features are preferably enabled by using a feed screw, although other configurations and systems are also possible.

Referring to Figs 2 and 3, the hydrocarbon rich slurry 14 is transferred from the solubilization unit 12 to the depolymerization unit 16. This fluid transfer can involve certain challenges. For example, in a continuous system in which the transfer line is in fluid communication between the solubilization unit 12 and the depolymerization unit 16, there can be certain backflow and back-heating issues. In particular, the hydrocarbon rich slurry 14 from the solubilization unit 12 is thicker (higher viscosity) and cooler compared to the mixture in the depolymerization unit 16, which is operated at higher temperatures (e.g., about 260°C to about 300°C). The temperature difference between the two units 12, 16 can be, for example, between about 80°C to about 120°C, which can result in a notable viscosity difference. Under a gravity-based slurry transfer mechanism, backflow and/or back-heating can occur and can result in process upsets and process control difficulties. Thicker and cooler slurry from the solubilization unit 12 transfers into the depolymerization unit 16 as long as the level differential favors the solubilization unit 12, which presents process limitations. For instance, there could be backflow of material from the depolymerization unit 16 into the solubilization unit 12 as the hotter and less viscous slurry can have a greater tendency of flowing back. Such backflow and other heat transfer mechanisms can slowly increase the temperature in the solubilization unit 12. Even though biomass is fed to it at ambient temperatures, which cools the medium in

the vessel 46, there is a risk that the comfortable or optimal process temperature levels in the solubilization unit 12 can be exceeded over time (e.g., exceeding 200°C). In addition, if the level differential between the two units 12, 16 is lost (which can be detected by the level measurement device 57), the gravity flow ceases and this overall operating method can be challenging to maintain. It can also be said that when the temperature differential between the two units 12, 16 is lost, reversible flow would be stopped.

In order to advantageously transfer slurry 14 from the solubilization unit 12 to the depolymerization unit 16, various systems can be implemented. For example, a slurry transfer device 58 can be provided and operated to ensure downstream slurry transport such that backflow and back-heating issues are mitigated or eliminated. In one implementation, the slurry transfer device 58 includes a pump that is configured and operated to displace the process mixture from the solubilization unit 12 to the depolymerization unit 16 by force. This enhances the stability of the system from the process conditions point of view.

Various different transfer system configurations incorporating piping, at least one pump, and other optional units, can be used. For example, referring to Fig 3, the transfer system between the solubilization unit 12 to the depolymerization unit 16 can include an upstream pipe section coupled to a pump which is coupled to a downstream pipe section that, in turn, is in fluid communication with an inlet of the depolymerization unit 16. Various different types of pumps can be used, e.g., rotary pump, Lobe pump, or other pumps particularly those suited for slurry transport.

Furthermore, referring to Fig 3, the transfer system between the solubilization unit 12 to the depolymerization unit 16 can include a control system 60 for controlling the pump 58 in accordance with measured characteristics (e.g., temperature and/or viscosity) of the slurry 14 at one or more locations (e.g., upstream or downstream of the pump, proximate or remote from either unit 12, 16). The control system 60 can also be used to control valves 64 and other features of the process. For instance, a temperature probe can be deployed to measure the temperature of the slurry stream 14, and the pump 58 can be operated accordingly. In addition, there may be a bypass line 62 and valves 64 that can be controlled so that the pump 58 is engaged when needed (e.g., when backflow or back-heating is detected or exceeds a threshold value). The control system 60 can also

be coupled to the solubilization unit 12 and/or the depolymerization unit 16 to control the temperature conditions therein in response to characteristics of the slurry.

Referring to Fig 2, there can be multiple outlet slurry lines (which can be seen as characters 14 and 14', for example) from the solubilization unit 12. At least one of the slurry lines can be coupled to the slurry transfer device 58 (14 in Fig 2) while the other slurry line can be arranged for gravity-based transfer (14' in Fig 2). A control unit can be configured and used so that the slurry is transported via one or both of the lines 14, 14' depending on operating parameters.

Still referring to Fig 2, it is noted that the slurry 14 can be fed directly from the solubilization unit 12 to the depolymerization unit 16 (e.g., via the slurry transport system 58, see line 14 of Fig 2) or the slurry can be fed into the separator 22 and a slurry recycle stream 66 can be withdrawn from the separator 22 and fed into the depolymerization unit 16. It is also noted that both can be implemented (simultaneously or alternately), as illustrated in Fig 2, where the slurry recycle stream 66 is first combined with the slurry stream 14 and then fed into the depolymerization unit 16.

It is also noted that other lines can be provided, such as a dump line 68 that supplies the slurry 14 into a storage tank 70, which may be done during process upset conditions, off-spec slurry conditions, emergency circumstances, and so on. A reintroduction line 72 can be used to reintroduce fluids in the storage tank 70 back into the feed sent to the depolymerization unit 16 (as illustrated) or back into the solubilization unit 12 (not illustrated here).

Turning to Fig 3, the solubilization vessel 46 can be equipped with a cooling system 74 such as a jacket 76 coupled to cooling fluid 78 or other means for cooling and facilitating temperature control. The cooling fluid can flow through a heat exchanger 80. In addition, a temperature control system 82 can be provided to control the temperature in the vessel 46. The temperature control system 82 can be coupled to one or more temperature sensors, and to process control points to regulate the feed of biomass, recycled organic liquid, outlet slurry, and cooling fluid. The cooling system 74 can be part of an integrated heat exchange loop for controlling temperatures in various units of the overall process.

Depolymerization

Referring to Fig 2, the hydrocarbon rich slurry 14 is supplied into the depolymerization unit 16 to enable advancement of depolymerization reactions.

The depolymerization unit 16 can have various designs and features. The depolymerization unit 16 can be provided to perform what is generally known in the industry as “catalytic pressureless depolymerization” (CPD) although other catalytic depolymerization methods can also be used.

In some cases, the depolymerization unit 16 can include a friction turbine, which can provide the primary heat source for the depolymerization reactions. It is nevertheless noted that upstream heat exchangers and/or in situ heating with heating devices can be provided. In friction turbine cases, the rotation speed, controlled by a frequency drive, creates vacuum conditions where the depolymerization reactions are occurring. In other reactor designs, the temperature and pressure conditions can be provided by other means. The temperature of the rich hydrocarbon slurry 14 can be increased to approximately 260-300°C by re-circulation through the friction turbine, at which point the long polymers of cellulose, hemicellulose and lignin, as the main constituents of the biomass, are broken down into alkanes, saturated and short-chain hydrocarbons. The exact mechanisms of depolymerization depend on the specific feedstock composition and process conditions, and can be determined by operating experience. In terms of the biomass constituents, hemicellulose is first converted into diesel range alkanes, followed by the conversion of cellulose and lignin. The residence time in the friction turbine reactor (e.g., 16 in Fig 2) can be between one to a few seconds. For other reactor designs, the residence time can be longer. The mixture of newly generated diesel, in gaseous form, along with carbon dioxide and other liquids leave the turbine 16 and enter a top section of the phase separator 22. Driving oxygen out from the biomass compounds during the molecular recombination in the process generates some carbon dioxide. By driving oxygen out via the carbon dioxide stream, the diesel range compounds are left without oxygen (or highly depleted in oxygen), which facilitates high product stability. It is again noted that various other reactor designs can be used instead of a friction turbine to effect depolymerization.

Referring still to Fig 2, in this optional process configuration, the feed to the depolymerization unit 16 includes the slurry 14 as well as a recycle stream 66 from the slurry phase at the bottom of the separator 22. The output hydrocarbon stream 18 from

the depolymerization unit 16 is thus a complex mixture of hydrocarbons and other compounds that will be separated upon entry into the separator 22. The separator 22 is operated so that the desired hydrocarbon products (e.g., diesel) are gaseous at the process conditions of the separator 22, and are thus recuperated via the overhead system 86 as a raw hydrocarbon product stream 88. Meanwhile, the components of the output hydrocarbon stream 18 from the depolymerization unit 16 that are liquid at the process conditions of the separator 22 separate with the bottom fraction and can be recirculated back into the depolymerization unit 16 for further depolymerization reactions. It is noted that this depolymerization-separation dual unit configuration with recirculation of slurry from the separator is one preferred configuration, and that various other process configurations can be used with or without recirculation depending on the conditions and the equipment that is used.

Regarding the depolymerization unit 16, while a friction turbine or vacuum pump can be optional equipment that can be used, various other CPD reactors or other types of depolymerization reactors can be used in the process. Preferably, the depolymerization unit 16 is configured to employ high-intensity conditions at relatively short residence times, and can be included in a loop with the phase separator 22, which will be described in further details below. The operating conditions in the depolymerization unit 16 are preferably provided so that the output stream is a mixture of gas-phase hydrocarbons, light liquid-phase hydrocarbons, heavy liquid-phase hydrocarbons, small amounts of water, and some particulate solids (organic and inorganic), so that this mixture can then be separated into gas and liquid/slurry phases in the separator 22 and the liquid/slurry phase can then be reintroduced into the depolymerization unit 16. This loop-type configuration is a preferred method of depolymerization and separation of the desired product components. However, it should be noted that, in some implementations, other configurations can be used to produce desired hydrocarbon components.

Phase separation

As mentioned above, the main output stream 18 produced by the depolymerization unit 16 is a mixture of gases and light and heavy liquids. Preferably, the depolymerization unit 16 has a single output stream 18, although it is possible that the depolymerization unit could have multiple outlet. The hydrocarbon stream 18 is fed into the phase

separator 22. The gaseous compounds (e.g., diesel and carbon dioxide) leave the phase separator 22 through a distillation column 90 mounted on top of the phase separator vessel 22, then immediately after being condensed and discharged out of the process. In particular, the gaseous overhead stream 88 is fed to a quencher 92, to produce a quenched stream 94 that is supplied to an oil-water separator 96. The water 98 is separated, cooled in a water cooler 100, and then sent to a holding tank 102. The liquid hydrocarbon stream 104 is separated, fed through a hydrocarbon cooler 106 and then into a hydrocarbon holding tank 108, after which it is sent via a hydrocarbon pump 110 to the purification unit 26.

In some implementations, the purification unit 26 includes a distillation vessel that produces at least a purified upper hydrocarbon fraction 112 and a bottom fraction 114. The distillation vessel can be operated in batch mode, such that a proportion of hydrocarbons are fed from the holding tank 108 into the distillation vessel which is then operated until the top and bottom fractions are produced. In some implementations, the distillation vessel can produce two, three or more cuts and/or can be operated in continuous mode. As shown in Fig 2, the upper hydrocarbon fraction 112 can be supplied to a product cooler 116 and then to a product tank 118, from which the hydrocarbon can be transported for final storage, pipelining, and the like, as the final diesel product 28. More regarding the purification unit 26 will be discussed further below.

In terms of process operating conditions in the separator 22, the process temperatures in the phase separator can be approximately 280°C, and can be controlled by a cooling loop to maintain optimal diesel yield. Residence time in the phase separator 22 can be set at between 30 and 60 minutes. It is noted in this regard that the separator 22 operating conditions can be paired and coordinated with the desired phase separation (i.e., depending on the desired gaseous hydrocarbon components that are to be removed) and with the operation of the depolymerization unit 16 when recycling of the liquid phase back to depolymerization is envisioned as part of the process. In some advantageous setups, there are no heat exchangers between the separator 22 and the depolymerization unit 16, and the units are operated at generally similar temperatures. Alternatively, in some cases, it may be desirable to have heat exchangers (e.g., heater and cooler) in between the two vessels, for example when higher temperatures are desirable for depolymerization and lower temperatures are desirable for the target phase separation, or vice versa.

In the phase separator 22, the heavier liquid fraction moves towards the bottom of the phase separator where it is redirected into the depolymerization unit 16 again for more diesel production until eventually a heavy residue mixed with ash and catalyst settles to the bottom of the separator 22. To avoid accumulation of heavy oil and ash/catalyst particulates, the separator residue 33 can be frequently discharged into the residuals treatment unit 30 (which can also be called an ash treatment unit) for catalyst and oil recovery, which will be discussed further below.

Referring to Fig 2, a separator underflow stream 120 can be withdrawn from the bottom of the separator 22 and can then be used in various ways. In some implementations, as illustrated, at least a portion of the separator underflow stream 120 can be returned as a recirculation stream 122 back into the vessel. Since the bottom fraction in the separator 22 is a slurry that includes small particulate material of various compositions suspended in an organic phase, solids can tend to deposit on the inner wall surfaces of the separator 22. Such deposition can be exacerbated due to the relatively high viscosity and solids rich medium in the lower part of the separator 22, which can cause stagnation which can, in turn, promote deposition or agglomeration and, in some cases, plugging of lines. Thus, mixing in the bottom fraction of the separator 22 can keep the particulate solids in suspension, promote the solids flow with the organic phase back into the depolymerization unit 16 as the slurry recycle stream 66, and reduce deposition and plugging.

In some implementations, the recirculation stream 122 can be used to induce mixing sufficient to inhibit deposition and plugging. Thus, the solids rich slurry at the bottom of the separator 22 is withdrawn and recirculated back into the slurry phase in the separator 22. A recirculation pump 124 can be used to recirculate the slurry, and there may be one or multiple recirculation inlet lines 126a, 126b back into the separator 22. In addition, by withdrawing and recirculating the bottoms of the separator, the heavier organic compounds can also be reintroduced into the bulk of the bottom fraction of the separator, so that they can be recycled back into the depolymerization unit 16. Thus, the recirculation enables mixing, inhibits deposition and pugging, and facilitates further processing of the heavy bottom components to depolymerize and extract remaining oil.

Fig 2 also shows that the recirculation system can send back a recirculated portion (e.g. stream 122) of the separator underflow stream 120, while a remaining portion can be

supplied to another unit, which may be downstream, such as the residue treatment unit 30. It should be noted that various proportions of streams 122 and 33 can be envisioned.

In addition, the recirculation can be done in various ways and can include one or multiple recirculation lines configured to return material back into the separator 22. In Fig 2, two recirculation inlet lines 126a, 126b are illustrated one above the other on the same side of the separator 22, although various other arrangements are possible. For instance, two recirculation inlet lines can be provided at different heights and/or at different locations around the separator 22. The recirculation inlet lines can be positioned and operated so that mixing occurs at desired locations of the bottom liquid fraction of the separator 22. For example, the recirculation inlet lines can be provided in sufficient number and orientation so that substantially all of the inner wall surfaces of the separator 22 that are susceptible to fouling can be proximate to agitated fluid. The recirculation inlet lines can also be in fixed positions or can be displaceable to provide variations in terms of the direction of the inlet flow. In addition, the recirculation inlet lines can be controlled to have the same or different flow rates entering the separator 22, as well as at different times. Valves and controls can be provided on the recirculation inlet lines to vary the flow rates, for example. The recirculation inlet lines (e.g., flow rate, direction, etc.) can be controlled actively in response to measured variables, or they can be run in a relatively constant manner (automatically or manually). It is also noted that the recirculation inlet lines can be operated to continuously supply material into the separator 22, or periodically supply such material (e.g., operated in on/off modes, where the on-mode can be a fixed or variable flow rate).

The recirculation system provided for the separator 22 facilitates preventing fouling of the vessel while allowing for both discharge of the heavy solids stream from the bottom of the separator and frequent transfer to the residue treatment unit 30.

It is also noted that the pump 124 can be operated periodically so that when not operating the solids and heavy liquids drop down to the bottom of the separator, and when turned on the heavy solids rich bottom phase is evacuated from the separator 22 and can be sent to the ash plant 30, the recirculation system, or a combination thereof.

Purification

In some implementations, the purification unit 26 includes a distillation vessel that produces at least a purified upper hydrocarbon fraction 112 and a bottom fraction 114. The distillation vessel can be operated in batch mode, such that a proportion of hydrocarbons are fed from the holding tank 108 into the distillation vessel which is then operated until the top and bottom fractions are produced. In some implementations, the distillation vessel can produce multiple cuts and/or can be operated in continuous mode.

Referring to Fig 2, the bottom fraction 114 can be fed to a tank, which can be the same storage tank 70 that is used periodically for holding slurry, as discussed above. The tank 70 can have a discharge 71 from which undesirable material is drained, e.g., for disposal, rather than being recycled back into the process. As illustrated, various bottom/underflow streams can be supplied to the storage tank 70, which can be done during upset conditions or at other times.

The upper hydrocarbon fraction 112 is supplied to a product cooler 116 and then to a product tank 118, from which the hydrocarbon can be transported for final storage, pipelining, and the like, as the final hydrocarbon (e.g., diesel) product 28. In some implementations, this hydrocarbon stream 28 is a final product, such as diesel fuel, that can be sold to market. However, it should also be noted that the hydrocarbon stream could be an intermediate that can be subjected to further upgrading, separation, conversion or reaction to produce other final products. Depending on the purification unit 26 that is used, the resulting upper hydrocarbon fraction 112 or other fractions (e.g., a middle fraction) that may be withdrawn from the purification unit 26 may have different compositions and properties and may, in some cases, benefit from further processing. Nevertheless, it is preferable that the purification unit 26 consist of a single separation vessel, such as a distillation tower, that produces the upper hydrocarbon fraction 112 that can simply be cooled and transported for final storage, pipelining or sale as a product.

It is also noted that the overall purification stage can include not only distillation but also various polishing or filtering steps, for instance to ensure no fine char particulates end up in the product storage. Other purification and/or separation steps can be implemented prior to the distillation step. In addition, prior to distillation, there may be a pre-heating step (not illustrated) that can be implemented in various ways depending on the setup and operation of the distillation tower.

Thus, in some implementations, when raw diesel is made from the depolymerization-separation loop, its quality can be improved by secondary distillation 26. Raw diesel (e.g., stream 88) can have some traces of water and other impurities and traditionally benefits from thermal treatment to improve quality parameters. This purification step can be operated as independent from the rest of the process setup, functioning on a batch basis where a volume of raw diesel is transferred into the purification unit 26 and purified by first taking out petroleum light ends (e.g., at around 175°C), then distilling the remaining volume (e.g., at around 300-320°C). The secondary distillation output can be referred to as finished diesel.

Residuals and ash processing

The residuals treatment unit 30 (which can also be referred to as an ash plant) facilitates recovery of heavier phase organics for supply back into the process, thereby enhancing overall recovery of hydrocarbons as valuable products and also reducing waste generation. The ash plant can also facilitate recovery of catalyst for reuse in the process. The ash plant further enables drying of inorganic materials (e.g., ash from wood) for reuse or disposal in dry form.

The ash plant is, however, an optional unit in the overall process. For example, in some scenarios, the bottom fraction from the separator (e.g., stream 33) could be sold as an industrial fuel material in which case no ash plant would be used in the overall process. The phase separator can produce bottom residue that is a high energy value stream, similar to Bunker C, and as such can be utilized in boilers and furnaces/kilns burning heavy oils for heat.

Preferably, the process includes recovery of the organics in stream 33 by putting them back into the process for additional diesel production. The ash plant can be a kiln-like device that operates in a range of 400-450°C, where a heavy oil-containing steam is exposed to the high temperature, allowing organics to evaporate from the ash/catalyst mixture and solids to be dried before discharge and final disposal. Thus, at least a portion of the separator bottoms stream 33 is sent to the ash plant 30, which generates a gaseous hydrocarbon stream (which also can be called a recovered hydrocarbons stream 34) and a solids enriched stream 128. The gaseous hydrocarbon stream 34 can then be condensed in a condenser 130 to produce a recovered hydrocarbon liquid 132

which can be fed to a holding tank 134. The recovered hydrocarbon liquid 132 can then be recycled back into the process.

In some implementations, the recovered hydrocarbon liquid 132 can be held in a feed tank 136 and fed back into the solubilization vessel 46. As noted above, the recovered hydrocarbon liquid 132 gradually takes the place of the organic carrier fluid used at the beginning of the process. The recovered hydrocarbon liquid 132 can be provided for dilution of the biomass and can be dosed based on one or more measured variables in the solubilization unit 12. For example, the torque of the mixer 47 can be measured and the amount of recovered hydrocarbon liquid 132 fed into the solubilization vessel 46 can be based on the torque, such that higher torque indicates too much biomass and thus more recovered hydrocarbon liquid 132 is supplied into the vessel 46. Various valves 138 and a feed pump 140 can be provided to supply the recovered hydrocarbon liquid 132 from the feed tank 136 into the solubilization vessel 46. The flow rate of the recovered hydrocarbon liquid 132 into the solubilization vessel 46 can also be based on other factors, such as the flow rate of the biomass feedstock, operation of the feed screw (e.g., rotation speed), temperature or viscosity measurements of the slurry in the vessel 46, dissolution rate of the biomass, and so on. If the biomass dissolution rate is lower than desired, additional recovered hydrocarbon liquid can be added to dilute the mixture and thus promote solubilization. In some implementations, the recovered hydrocarbon liquid 132 is recycled for use as a top-up organic liquid in the solubilization unit 12 in combination with another organic liquid (e.g., carrier liquid).

It should be noted that the recovered hydrocarbon liquid 132 can be supplied to other units of the process as well, depending on the setup of the process. For example, in some implementations, a portion of the recovered hydrocarbon liquid 132 can be supplied into the depolymerization unit 16, the phase separator 22, and/or the feed lines thereto.

Hydrocarbon products

In the preferred implementation, at least a diesel product is produced as the final output of the process. As explained above, depending on the operation of the various units, other hydrocarbon cuts, intermediates and/or products can be produced for sale.

On the downstream side of the technology, production of the hydrocarbon product (e.g., diesel) can help meet growing market demand for cellulosic feedstock based sources of renewable or clean fuels. Both legislation and evolving end-user sentiment about climate change and the environmental footprint of their activities are contributing to this demand. To date, many varying pathways have been developed or are being developed to try to address the same opportunity. However, challenges with economics and quality have led to limited success. Processes described herein facilitate distinct advantages over existing processes, such as lower capital cost, low supply chain cost and drop-in or high-blend wall product quality.

It should also be noted that by-products can also be produced by various units in the process, e.g., bottom streams that have high energy content and can be sold as fuels or intermediates for upgrading, various distillation cuts, and so on.

Additional comments on technology implementations

The conversion of biomass to liquid fuels can be achieved via many pathways. Pyrolysis, gasification, catalytic conversion and fermentation are some leading pathway platforms that are being developed today. It is challenging to compare the competitiveness of technology platforms in and of themselves, as the overall economic viability is also a function of many other business dynamics. As an example, pyrolysis or fast pyrolysis has proven a viable technical platform for the conversion of biomass to a liquid fuel. Its performance has a comparable yield, capital cost footprint and conversion cost per unit to the preferred catalytic depolymerization techniques described herein. A disadvantage of the pyrolysis methods is their lower product quality. Pyrolysis products, often referred to as bio-crude, require further upgrading to be integrated into end-use applications. This is disadvantageous because large-scale refining platforms may not wish to integrate small volumes of bio-crude with differing properties to their crude sources. Gasification followed by a Fischer-Tropsch (or similar proprietary) back-end has also been demonstrated to convert biomass to liquid fuels. In this case the yield and product quality are comparable to the preferred catalytic depolymerization techniques described herein; however, they have higher cost per unit of output. As a result, these projects pursue large scales to improve this dynamic, which has resulted in challenges to run scaled-up gasification equipment consistently with a variable feedstock, such as biomass. The preferred catalytic depolymerization techniques described herein, which include a

solubilization step followed by depolymerization below pyrolysis conditions and then phase separation and purification steps, facilitates superior product quality, economic feasibility on a distributed production footprint and access to sustainably priced biomass.

Thus, in some preferred implementations, the various innovative aspects described herein can be used with a catalytic depolymerization technology platform, where the biomass is solubilized and then subjected to catalytic depolymerization below pyrolysis conditions, followed by phase separation and then purification of the separated diesel-range hydrocarbon stream. Nevertheless, various innovative aspects described herein can also be used in connection with other technology platforms that include unit operations such as biomass solubilization, organic slurry transport between a lower temperature unit and a higher temperature unit, separation vessels or reactors in which the bottom fraction includes solid and heavy liquid components that may tend to deposit and plug equipment if not kept in suspension or agitated, and so on. In addition, while preferred implementations have been described in detail herein with respect to producing a diesel product, various innovative aspects can also be used in connection with processes for producing other hydrocarbon products from biomass.

CLAIMS

1. A process for producing diesel from biomass, comprising:
 - supplying cellulosic biomass to a solubilization unit to form an organic slurry comprising solubilized carbonaceous material, wherein the cellulosic biomass is supplied in particulate form via a plug screw feeder into the solubilization unit;
 - supplying the organic slurry to a depolymerization unit to depolymerize carbonaceous polymers contained in the organic slurry and produce a treated hydrocarbon stream;
 - supplying the treated hydrocarbon stream to a phase separator to produce at least an upper gaseous hydrocarbon stream and a bottom slurry phase; and
 - supplying the gaseous hydrocarbon stream to a purification unit to produce a diesel stream.
2. The process of claim 1, wherein the cellulosic biomass comprises sawdust from wood processing.
3. The process of claim 1 or 2, wherein the cellulosic biomass supplied to the solubilization unit has particle sizes of at most 3 mm.
4. The process of claim 1 or 2, wherein the cellulosic biomass supplied to the solubilization unit has particle sizes between 1 mm and 3 mm.
5. The process of any claim 3 or 4, wherein the cellulosic biomass is subjected to pre-grinding to obtain the particle sizes.
6. The process of any one of claims 1 to 4, wherein the cellulosic biomass is subjected to pre-drying so as to have a moisture content of about 5 wt% to about 15 wt prior to supply into the solubilization unit.

7. The process of any one of claims 1 to 6, wherein the cellulosic biomass is supplied into the solubilization unit below a liquid level of the organic slurry therein.
8. The process of any one of claims 1 to 7, wherein the solubilization unit comprises an internal mixer operable to mix the organic slurry and promote solubilization.
9. The process of any one of claims 1 to 8, further comprising recycling a portion of the bottom slurry phase back into the depolymerization unit.
10. The process of any one of claims 1 to 9, further comprising supplying at least a portion of the bottom slurry phase from the phase separator to a residuals treatment unit to produce a recovered hydrocarbon gas and a solids enriched bottom fraction; condensing the recovered hydrocarbon gas to produce a recovered hydrocarbon liquid; recycling at least a portion of the recovered hydrocarbon liquid back into the solubilization unit to form part of the organic slurry.
11. A process for producing diesel from biomass, comprising:
 - supplying cellulosic biomass to a solubilization unit to form an organic slurry comprising solubilized carbonaceous material, wherein the cellulosic biomass is supplied in particulate form below a liquid level of the organic slurry in the solubilization unit;
 - supplying the organic slurry to a depolymerization unit to depolymerize carbonaceous polymers contained in the organic slurry and produce a treated hydrocarbon stream;
 - supplying the treated hydrocarbon stream to a phase separator to produce at least an upper gaseous hydrocarbon stream and a bottom slurry phase;
 - recycling a portion of the bottom slurry phase back into the depolymerization unit;
 - purifying the gaseous hydrocarbon stream to produce a diesel stream.

12. A process for producing diesel from biomass, comprising:

supplying cellulosic biomass to a solubilization unit to form an organic slurry comprising solubilized carbonaceous material, wherein the solubilization unit is operated at a solubilization temperature between 160°C and about 200°C;

supplying the organic slurry to a depolymerization unit to depolymerize carbonaceous polymers contained in the organic slurry and produce a treated hydrocarbon stream, wherein the depolymerization unit is operated at a depolymerization temperature between 260°C and about 300°C;

operating a fluid transfer system to supply the organic from the solubilization unit to the depolymerization unit such that back-flow and back-heating from the depolymerization unit toward the solubilization unit are inhibited;

supplying the treated hydrocarbon stream to a phase separator to produce at least an upper gaseous hydrocarbon stream and a bottom slurry phase; and

purifying the gaseous hydrocarbon stream to produce a diesel stream.

13. The process of claim 12, wherein the fluid transfer system comprising an outlet line for withdrawing the organic slurry from the solubilization unit, at least one pump coupled to the outlet line for receiving the organic slurry therefrom and pumping the organic slurry downstream, and a downstream line coupled to the pump for receiving the organic slurry therefrom and supplying the organic slurry into the depolymerization unit.

14. The process of claim 13, further comprising measuring at least one process variable, and adjusting the pump based on the measured process variable.

15. The process of claim 14, wherein a slurry temperature of the organic slurry is measured in the solubilization unit, the outlet line and/or the downstream line,

and the pump is controlled to regulate transfer of the organic slurry in order to maintain the slurry temperature below a pre-determined threshold.

16. The process of claim 14 or 15, wherein the pump is controlled to increase the flow rate of the organic slurry from the solubilization unit to the depolymerization unit in response to a measured back-heating of the organic slurry upstream of the depolymerization unit.
17. The process of any one of claims 14 to 16, wherein the pump is controlled to increase the flow rate of the organic slurry from the solubilization unit to the depolymerization unit in response to a measured viscosity reduction of the organic slurry upstream of the depolymerization unit.
18. The process of any one of claims 12 to 17, further comprising recycling a portion of the bottom slurry phase back into the depolymerization unit.
19. The process of claim 18, wherein the recycled portion of the bottom slurry phase is fed back into the downstream line upstream of the depolymerization unit.
20. A process for producing diesel from biomass, comprising:
 - supplying cellulosic biomass to a solubilization unit to form an organic slurry comprising solubilized carbonaceous material;
 - supplying the organic slurry to a depolymerization unit to depolymerize carbonaceous polymers contained in the organic slurry and produce a treated hydrocarbon stream;
 - supplying the treated hydrocarbon stream to a phase separator to produce at least an upper gaseous hydrocarbon stream and a bottom slurry phase comprising liquid hydrocarbons and solid particulate material;
 - withdrawing an underflow stream comprising the bottom slurry phase from the phase separator;
 - recirculating at least a portion of the underflow stream as a recirculated stream back into the phase separator to provide agitation of the bottom

slurry phase within the phase separator to inhibit deposition on the inner walls of the phase separator;

purifying the gaseous hydrocarbon stream to produce a diesel stream.

21. The process of claim 20, wherein the recirculating comprises pumping the recirculated stream back into the phase separator below a liquid level therein.
22. The process of claim 20 or 21, wherein the recirculating comprises feeding the recirculated stream back into the phase separator via a single inlet.
23. The process of claim 20 or 21, wherein the recirculating comprises feeding the recirculated stream back into the phase separator via at least two inlets.
24. The process of claim 23, wherein the at least two inlets are each located at different heights of the phase separator.
25. The process of claim 23 or 24, wherein the at least two inlets are each located at different locations around the periphery of the phase separator.
26. The process of any one of claims 20 to 25, wherein a first portion of the underflow stream is recirculated as the recirculated stream, and a second portion of the underflow stream is supplied to a downstream unit.
27. The process of claim 26, wherein the second portion of the underflow stream is supplied to a residuals treatment unit to produce a recovered hydrocarbon gas and a solids enriched bottom fraction.
28. The process of any one of claims 20 to 27, wherein the recirculating is controlled to vary a recirculation flow rate in response to a measured process variable.
29. The process of any one of claims 20 to 28, wherein the recirculating is operated continuously.
30. The process of any one of claims 20 to 28, wherein the recirculating is operated periodically.

31. The process of any one of claims 20 to 30, wherein the recirculating is performed such that the recirculated stream is fed into the bottom slurry phase at a fixed located and feed direction.
32. A process for producing diesel from biomass, comprising:
- supplying cellulosic biomass to a solubilization unit to form an organic slurry comprising solubilized carbonaceous material;
 - supplying the organic slurry to a depolymerization unit to depolymerize carbonaceous polymers contained in the organic slurry and produce a treated hydrocarbon stream;
 - supplying the treated hydrocarbon stream to a phase separator to produce at least an upper gaseous hydrocarbon stream and a bottom slurry phase comprising liquid hydrocarbons and solid particulate material;
 - supplying the gaseous hydrocarbon stream to a purification unit to produce a diesel stream;
 - supplying at least a portion of the bottom slurry phase to a residuals treatment unit to produce a recovered hydrocarbon stream and a solids enriched bottom fraction; and
 - recycling the recovered hydrocarbon stream back into the solubilization unit to form part of the organic slurry.
33. The process of claim 32, wherein the recovered hydrocarbon stream withdrawn from the residuals treatment unit is a recovered hydrocarbon gas, and the process further comprises condensing the recovered hydrocarbon gas to produce a recovered hydrocarbon liquid; and recycling the recovered hydrocarbon liquid back into the solubilization unit to form part of the organic slurry.
34. The process of claim 33, wherein the recovered hydrocarbon liquid is fed into the solubilization unit below a liquid level therein.

35. The process of claim 33 or 34, wherein the recovered hydrocarbon liquid is fed into the solubilization unit below a biomass feed inlet thereto.
36. The process of any one of claims 33 to 35, wherein the recovered hydrocarbon liquid is supplied to a feed tank, and then pumped from the feed tank into to the solubilization unit.
37. The process of any one of claims 33 to 36, wherein supply of the recovered hydrocarbon liquid is controlled based on a measure process variable of the solubilization unit.
38. The process of claim 37, wherein the measured process variable comprises slurry temperature of the organic slurry in the solubilization unit, and the supply of the recovered hydrocarbon liquid is controlled in accordance with the slurry temperature.
39. The process of claim 37, wherein the measured process variable comprises torque of a mixer deployed in the solubilization unit to mix the organic slurry, and the supply of the recovered hydrocarbon liquid is controlled in accordance with the mixer torque.
40. The process of claim 39, wherein supply of the recovered hydrocarbon liquid is increased in response to the measure toque exceeding a pre-determined threshold value.
41. The process of claim 39 or 40, wherein supply of the recovered hydrocarbon liquid is controlled to maintain a generally constant viscosity and/or torque in the solubilization unit.
42. The process of any one of claims 33 to 41, wherein the residuals treatment unit comprises a kiln or furnace operated at temperatures between 400°C and 450°C.

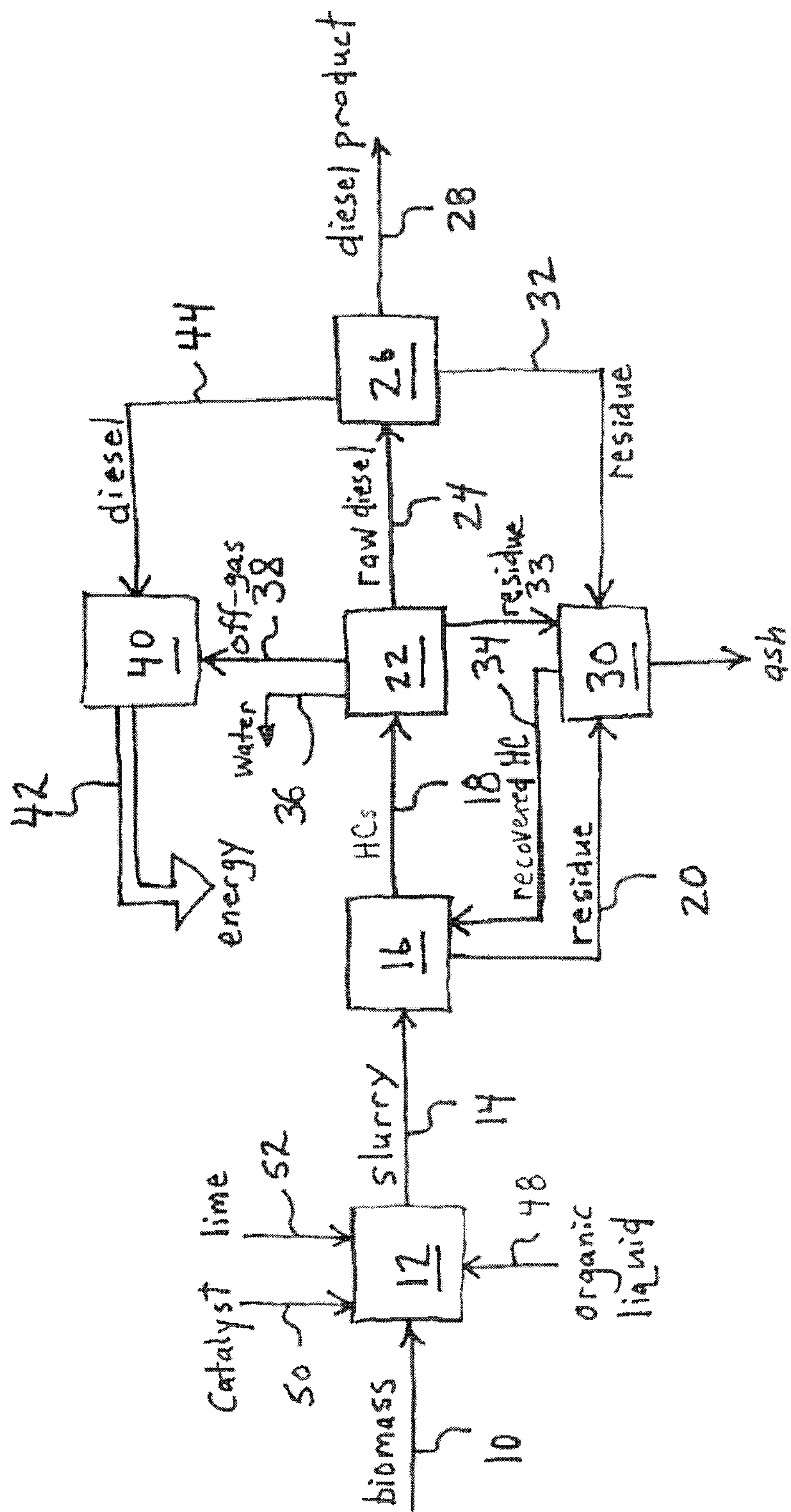

Fig 1

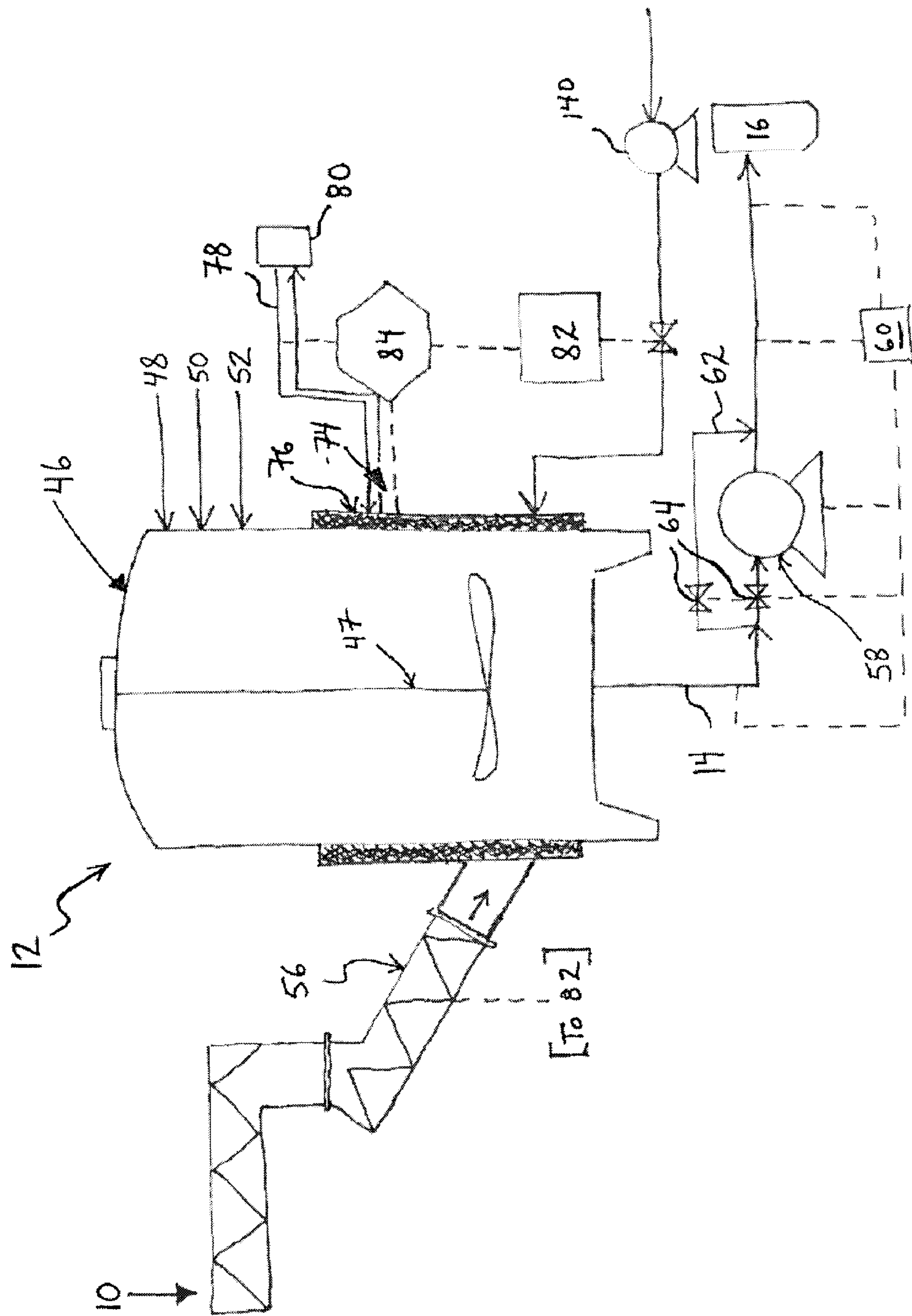

Fig 3

