

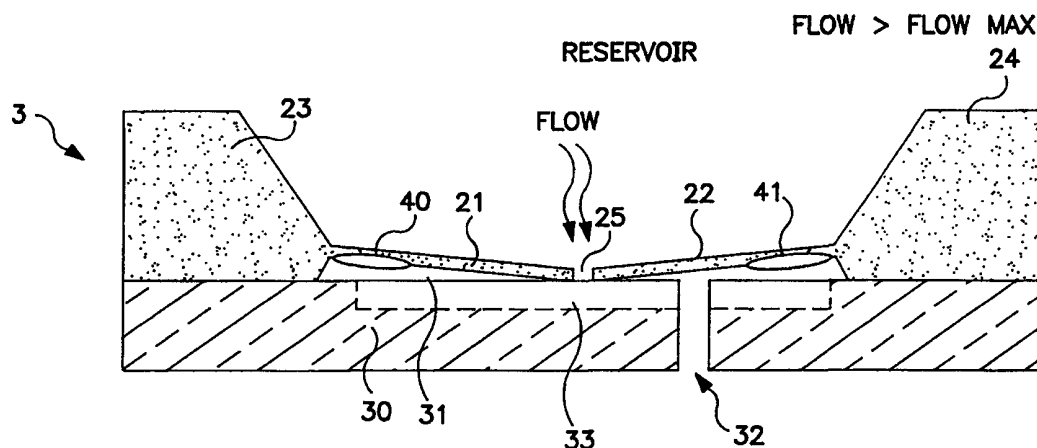

INTERNATIONAL APPLICATION PUBLISHED UNDER THE PATENT COOPERATION TREATY (PCT)

<p>(51) International Patent Classification⁶ : A61M 5/142, 5/168, G05D 7/01</p>	<p>A1</p>	<p>(11) International Publication Number: WO 99/38552</p> <p>(43) International Publication Date: 5 August 1999 (05.08.99)</p>
<p>(21) International Application Number: PCT/US99/02136</p> <p>(22) International Filing Date: 1 February 1999 (01.02.99)</p> <p>(30) Priority Data: 09/017,194 2 February 1998 (02.02.98) US</p> <p>(71) Applicant: MEDTRONIC, INC. [US/US]; 7000 Central Avenue, N.E., Minneapolis, MN 55432 (US).</p> <p>(72) Inventors: HALLER, Markus; Route de Burtigny 24, CH-1268 Begnins (CH). RENAUD, Philippe; Chemin Neuf 11, CH-1028 Preverenges (CH). AMACKER, Christian; Strichen, CH-3943 Eischoll (CH).</p> <p>(74) Agents: JARO, Michael, J. et al.; Medtronic, Inc., 7000 Central Avenue N.E., MS301, Minneapolis, MN 55432 (US).</p>	<p>(81) Designated States: AL, AM, AT, AU, AZ, BA, BB, BG, BR, BY, CA, CH, CN, CU, CZ, DE, DK, EE, ES, FI, GB, GE, GH, GM, HR, HU, ID, IL, IS, JP, KE, KG, KP, KR, KZ, LC, LK, LR, LS, LT, LU, LV, MD, MG, MK, MN, MW, MX, NO, NZ, PL, PT, RO, RU, SD, SE, SG, SI, SK, SL, TJ, TM, TR, TT, UA, UG, UZ, VN, YU, ZW, ARIPO patent (GH, GM, KE, LS, MW, SD, SZ, UG, ZW), Eurasian patent (AM, AZ, BY, KG, KZ, MD, RU, TJ, TM), European patent (AT, BE, CH, CY, DE, DK, ES, FI, FR, GB, GR, IE, IT, LU, MC, NL, PT, SE), OAPI patent (BF, BJ, CF, CG, CI, CM, GA, GN, GW, ML, MR, NE, SN, TD, TG).</p> <p>Published <i>With international search report.</i></p>	

(54) Title: IMPLANTABLE DRUG INFUSION DEVICE HAVING A FLOW REGULATOR



(57) Abstract

An implantable drug infusion device which features an improved flow regulator which permits the flow rate to be independent of reservoir pressure within a given pressure range. The flow regulator features a membrane having a hole, the membrane itself positioned above a bottom layer such that sufficient deflection of the membrane causes the membrane to engage against the bottom layer. As liquid flows through the hole a drag force is applied to the edge of the hole resulting in a deflection of the membrane. Once contact is made between the membrane and the bottom layer, then flow is reduced. In a further embodiment the bottom layer features a variable flow channel such that upon membrane deflection flow may only proceed through the hole and through the flow channel. By tailoring the shape and length of the variable flow channel the flow characteristics of the regulator versus pressure may be adjusted. In a further embodiment the flow regulator also features a flow sensor integrated therewith. This integrated sensor provides a measurement of flow and may be coupled to the flow regulator to provide feedback thereto.

FOR THE PURPOSES OF INFORMATION ONLY

Codes used to identify States party to the PCT on the front pages of pamphlets publishing international applications under the PCT.

AL	Albania	ES	Spain	LS	Lesotho	SI	Slovenia
AM	Armenia	FI	Finland	LT	Lithuania	SK	Slovakia
AT	Austria	FR	France	LU	Luxembourg	SN	Senegal
AU	Australia	GA	Gabon	LV	Latvia	SZ	Swaziland
AZ	Azerbaijan	GB	United Kingdom	MC	Monaco	TD	Chad
BA	Bosnia and Herzegovina	GE	Georgia	MD	Republic of Moldova	TG	Togo
BB	Barbados	GH	Ghana	MG	Madagascar	TJ	Tajikistan
BE	Belgium	GN	Guinea	MK	The former Yugoslav Republic of Macedonia	TM	Turkmenistan
BF	Burkina Faso	GR	Greece	ML	Mali	TR	Turkey
BG	Bulgaria	HU	Hungary	MN	Mongolia	TT	Trinidad and Tobago
BJ	Benin	IE	Ireland	MR	Mauritania	UA	Ukraine
BR	Brazil	IL	Israel	MW	Malawi	UG	Uganda
BY	Belarus	IS	Iceland	MX	Mexico	US	United States of America
CA	Canada	IT	Italy	NE	Niger	UZ	Uzbekistan
CF	Central African Republic	JP	Japan	NL	Netherlands	VN	Viet Nam
CG	Congo	KE	Kenya	NO	Norway	YU	Yugoslavia
CH	Switzerland	KG	Kyrgyzstan	NZ	New Zealand	ZW	Zimbabwe
CI	Côte d'Ivoire	KP	Democratic People's Republic of Korea	PL	Poland		
CM	Cameroon	KR	Republic of Korea	PT	Portugal		
CN	China	KZ	Kazakstan	RO	Romania		
CU	Cuba	LC	Saint Lucia	RU	Russian Federation		
CZ	Czech Republic	LI	Liechtenstein	SD	Sudan		
DE	Germany	LK	Sri Lanka	SE	Sweden		
DK	Denmark	LR	Liberia	SG	Singapore		
EE	Estonia						

**IMPLANTABLE DRUG INFUSION DEVICE
HAVING A FLOW REGULATOR**

RELATED APPLICATIONS

5 This application is related to one or more of the following each of which are filed on this same day, each incorporated herein by reference and each assigned to the assignee of the present application:

- United States patent application entitled "System For Locating Implantable Medical Device" of Markus Haller and Koen Weijand (Our File: P-7521);

10 - United States patent application entitled "Implantable Drug Infusion Device Having A Safety Valve" of Markus Haller and Koen Weijand (Our File: P-7354 (including P-7329); and

15 - United States patent application entitled "Implantable Drug Infusion Device Having An Improved Valve" of Markus Haller, T. S. J. Lammerink and Niels Olij (Our File: P-7356).

FIELD OF THE INVENTION

20 The present invention relates to the field of implantable drug infusion devices and more particularly to an implantable drug infusion device having a flow regulator.

BACKGROUND OF THE INVENTION

 Implantable drug infusion devices are used to provide patients with a constant or programmable long term dosage or infusion of a drug or any other therapeutic agent. Essentially such device may be categorized as either active or passive.

25 Active drug or programmable infusion devices feature a pump or a metering system to deliver the drug into the patient's system. An example of such an active drug infusion device currently available is the Medtronic SynchroMed™ programmable pump. Such pumps typically include a drug reservoir, a peristaltic pump to pump out the drug from the reservoir, and a catheter port to transport the
30 pumped out drug from the reservoir via the pump to a patient's anatomy. Such

5 devices also typically include a battery to power the pump as well as an electronic module to control the flow rate of the pump. The Medtronic SynchroMed™ pump further includes an antenna to permit the remote programming of the pump. Needless to say, in view of these various components, the cost as well as the size of active drug infusion devices is greater than desired.

10 Passive drug infusion devices, in contrast, do not feature a pump, but rather rely upon a pressurized drug reservoir to deliver the drug. Thus such devices tend to be both smaller as well as cheaper as compared to active devices. An example of such a device includes the Medtronic IsoMed™. This device delivers the drug into the patient through the force provided by a pressurized reservoir. In particular, this reservoir is pressurized with a drug to between 20 to 40 psi (1.3 to 2.5 bar) and is used to deliver the drug into the patient's system. Typically the flow path of the drug from the reservoir to the patient includes a flow restrictor, which permits a constant flow rate. The flow rate, however, is only constant, if the pressure difference between reservoir and patient does not change. Factors that could impact this pressure difference include temperature, pressure-volume dependence of reservoir and altitude, among others. The selected pressure for the reservoir is thus typically quite high, so that absolute pressure changes only cause small and acceptable errors in flow rate. This also requires, however, the drug to be injected into the reservoir using still higher pressure. This is often a very difficult to achieve using a hand operated syringe.

20 In addition such devices present challenges to accurately deliver a precise dosage of drug to the patient. As the amount of drug is removed from the reservoir, the pressure in the reservoir drops. This, in turn, affects the flow rate such that only over a limited pressure range will the flow rate be constant. Still further, because the ambient pressure changes in which the patient exists (due to weather or altitude for example) the resistance to drug infusion likewise changes, further affecting the flow rate. Temperature will also have a similar impact.

25 Thus there is a need for a drug infusion system which will permit the drug flow rate to be independent of reservoir pressure within a given pressure range.

SUMMARY OF THE INVENTION

The present invention provides an implantable drug infusion device which features an improved flow regulator which permits the flow rate to be independent of reservoir pressure within a given pressure range. The flow regulator features a membrane having a hole, the membrane itself positioned above a bottom layer such that sufficient deflection of the membrane causes the membrane to engage against the bottom layer. As liquid flows through the hole a force is applied to the membrane, resulting in a deflection of the membrane which, in turn, impedes the flow path. In a further embodiment the bottom layer features a variable flow channel such that upon membrane deflection flow may only proceed through the hole and through the flow channel. By tailoring the shape and length of the variable flow channel the flow characteristics of the regulator versus pressure may be adjusted. In a further embodiment the flow regulator also features a flow sensor integrated therewith. This integrated sensor provides a measurement of flow and may be coupled to the flow regulator to provide feedback thereto.

BRIEF DESCRIPTION OF THE DRAWINGS

FIG. 1 is a block diagram of an implantable drug infusion device according to the present invention.

FIG. 2 is a side view of a flow regulator according to the present invention in which the system pressure is low and the regulator membrane is not deflected.

FIG. 3 is a side view of a flow regulator according to the present invention in which the system pressure is high and the membrane is deflected.

FIG. 4 is a side view of a further embodiment of a flow regulator.

FIG. 5A is a top view of the variable flow restrictor channel used in the embodiment depicted in FIG. 4 of the present invention.

FIG. 5B is a sectional view of the variable flow restrictor shown in FIG. 5A.

FIG. 5C is a sectional view of an alternative variable flow restrictor channel.

FIG. 6 depicts the flow versus pressure for one embodiment of the present invention showing, in particular, the linear flow between the two pressures which may be permitted using this present invention.

FIG. 7 is a block diagram of an implantable drug infusion device which features an integrated self-test mechanism on the flow regulator.

FIG. 8 is a side view of a flow regulator which features an integrated self-test mechanism on the flow regulator.

FIG. 9 depicts the change in resistance of the piezo-resistors used in the flow sensors versus reservoir pressure.

The FIGS. are not necessarily to scale.

DETAILED DESCRIPTION OF THE DRAWINGS

FIG. 1 is a block diagram of an implantable drug infusion device and in particular of a passive system to deliver drugs and other therapeutic agents. As seen, such a system 1 comprises a reservoir 2, flow regulator 3 and outlet catheter 4. The reservoir is a pressurizable reservoir to hold drugs and other therapeutic agents. Reservoir may be of a standard design, such as that used in the above mentioned Medtronic IsoMed™ implantable drug infusion system. Flow regulator 3 is coupled to the reservoir and the outlet catheter. Flow regulator controls the flow of material which may be transmitted from the reservoir to the outlet catheter and in particular permits the flow rate to be independent of reservoir pressure within a given pressure range. System may be refilled through injection port 5 through the use of a needle 6 as is well known. Surrounding all components of the implantable pump other than the outlet catheter is a hermetic closure 13 as is well known in the art.

FIG. 2 is a side view of a flow regulator according to the present invention. In this view the reservoir pressure is low. As seen, flow regulator comprises a membrane 21, 22 cantilevered from shoulders 23 and 24 respectively. In the preferred embodiment membrane is circular, although other shapes may also be used, e.g. rectangular.

Center of the membrane features flow lumen 25. The membrane is further disposed above a substrate 30 such that cavity 31 is defined. Substrate 30, in turn, has an outflow tract 32 coupled to cavity 31. Thus, unless activated by pressure, the membrane remains in the position as shown and fluid flows through flow lumen 25 into cavity 31 and thereafter through outflow tract 32. Outflow tract is coupled, in turn, to outlet catheter (although not shown in this view). Outlet catheter may be of any model desired and suited to the patient's requirements. Depending on the amount of pressure exerted by the fluid, the membrane may be either in the position shown or deflected any amount as permitted by substrate 30. In the preferred embodiment shoulders and membrane are silicon and substrate is Pyrex™ glass, although other materials may also be used such as titanium or tantalum. Moreover, the areas of substrate and membranes in contact with any drug or fluid are further preferably coated with diamond or diamond-like carbon so as to inhibit any interactions between the drug or fluid and the materials. Such coatings may be selected according to the particular drug or fluid to be infused.

FIG. 3 is a side view of a flow regulator according to the present invention in which the system pressure is high. As seen in this embodiment, the pressure of the fluid causes the membrane to be deflected and strike against substrate 30. In such a manner the fluid pathway (flow lumen 25 into cavity 31 and thereafter through outflow tract 32) is blocked by the membrane itself and all fluid flow is thus stopped.

FIG. 4 is an additional embodiment of the present invention and, in particular, the preferred embodiment of flow regulator which features a variable flow restrictor channel 33. As seen in this embodiment, flow regulator features a variable flow restrictor channel which provides a pathway through which flow may continue even though the membrane is disposed against a surface in substrate 30. In particular, flow proceeds through lumen 25 into the variable flow restrictor channel 33 to the outlet 32. Because membrane strikes the top of substrate all flow is forced to go to the "beginning" of the variable flow restrictor channel. As more pressure is applied to the membrane by the fluid, the membrane is deflected to a greater degree, a greater contact area is made between the membrane and the substrate, and the fluid is forced

to flow through a longer pathway through the variable flow restrictor channel. In the preferred embodiment the length of the flow channel is directly proportional to the flow resistance. The increase in contact area due to pressure proportionally lengthens the distance in which the fluid flows exclusively within the flow channel. Thus the flow through the restrictor channel is directly proportional to the pressure applied to the fluid within that channel. This capability thus provides this embodiment with the ability to directly compensate pressure inaccuracies as well as pressure variations within any of the system components (upstream of the flow sensor) such as the reservoir, when such pressure anomalies are with the (upstream of the flow sensor) specified pressure region. Ultimately, this design permits the flow rate to be independent of reservoir pressure within a given pressure range.

FIG. 5A is a top view of a variable flow restrictor channel used in the preferred embodiment. As seen in this embodiment, restrictor channel is essentially spiral shaped according to the following equation:

$$x = \frac{a \cdot \cos t}{t} \quad \text{and} \quad y = \frac{a \cdot \sin t}{t} \quad \text{for } -\infty < t < 0 \text{ and } 0 < t < \infty$$

where "a" is 1 in the preferred embodiment, although any value between approximately 0.1 to 100 may also be chosen

FIG. 5B is a sectional view of the flow restrictor channel of FIG. 5A taken along the line 5B-5B. As seen in this embodiment, the restrictor channel is essentially square in shape and has a depth roughly equal to the width. Of course, other cross sectional shapes of restrictor channel may also be used, such as circular, as seen in FIG. 5C or other shapes, triangular, etc. What is important for the flow characteristics of the regulator, however, is the cross sectional area of the channel. In the preferred embodiment the channel has a width of 15 mm and depth of 10 mm which permits a essentially constant flow rate of 500 ml over a pressure range of between approximately 2 to 8 psi above ambient pressure. Moreover, although the cross sectional area and shape of the restrictor channel is constant in the preferred embodiment, either the shape or area or both may be varied along the various portions in order to provide other flow characteristics besides those of the preferred embodiment.

FIG. 6 is a graph showing the flow rate versus pressure of the preferred embodiment. As seen, due to the usage of the deflected leaflets in conjunction with the variable flow restrictor channel the flow rate may be caused to be constant over a pressure range. In this chart P1 is 2 psi, P2 is 8 psi and F1 is 500 ml.

5 FIG. 7 is a block diagram of an alternative embodiment of the present invention. As seen, such a system 1 comprises a reservoir 2, flow regulator/flow sensor 7, electronic controls 10, battery 11, telemetry assembly 12 and outlet catheter 4. Flow regulator/flow sensor 7 is coupled to the reservoir across safety valve 16 and further coupled to the outlet catheter across pump 17. Flow
10 regulator/flow sensor regulates the flow of material which may be transmitted from the reservoir to the outlet catheter by pump in a manner to the flow regulator already described above, i.e. it regulates flow such that flow rate is independent of reservoir pressure within a given pressure range. Moreover, in this embodiment, the flow regulator also functions as a flow sensor to permit the flow rate to be
15 sensed such that the device can track how much drug is delivered. Further, this component also permits the device to test itself so as to check and monitor the actual flow rate. As already described above, the system may be refilled through injection port 5 through the use of a needle 6 as is well known. Surrounding all
20 components of the implantable pump other than the outlet catheter is a hermetic closure 13 as is well known in the art. Electronic controls 10, battery 11, telemetry assembly 12 and pump 17 are all constructed in any manner well known in the art. Electronic controls are powered by battery 11 and may receive remote operation instructions via telemetry assembly 12, as is well known in the art. Safety valve is preferably of a design as shown in the co-pending application of Haller et al.
25 "Implantable Infusion Device Having Safety Valve" (P-7356) filed this same day and incorporated herein by reference.

FIG. 8 is a side view of a flow regulator/flow sensor used in the system of FIG. 7. As seen, this embodiment is essentially the same as that shown in FIG. 4. That is, flow regulator comprises membrane 21 cantilevered from shoulders 23 and
30 24 respectively disposed above a variable flow restrictor channel within substrate

30. As already discussed above, channel provides a pathway through which flow may continue even though the membrane is disposed against the surface of substrate 30. In the present embodiment, the flow regulator/flow sensor further features one or more piezo-resistive elements 40, 41 integral with the membrane such that deformation or bending of the leaflets is detected by the elements. Such elements are coupled to the electronic controls, which process the signals and extract information as to element deformation and thus flow through the valve. Although piezo-resistive elements are used, other types of elements may also be used, such as capacitive or inductive.

FIG. 9 is a graph showing the change in resistance to flow versus pressure of the preferred embodiment. As seen, due to the usage of the deflected membrane in conjunction with the variable flow restrictor channel the change in resistance to flow increases in proportion to the pressure.

FIG. 10 is a flow chart depicting the steps used of a self-test feature made possible through the one or more piezo-resistive elements 40, 41 integral with the membrane. In particular this feature is used to quantify membrane deflection. This is important because, the membranes may, over time, take a set, that is exhibit a permanent deflection. Thus the self test permits the membrane position to be precisely measured. Such information may be then used to assess device operation, e.g. the actual flow rate of fluid through the regulator. amount of refill reservoir required by the or device malfunction. Typically this self test procedure is performed at device implant or follow-up by the physician.

As seen in FIG. 10 at 10-1 a first amount of energy is apply across one or more piezo-resistive elements 40, 41. Next at 10-2 a parameter indicated through the first amount of energy is sensed. Such parameters may include resistance, impedance or capacitance, for example. Because in the preferred embodiment the elements are piezo-resistive, then the parameter preferably sensed would be the electrical resistance in the elements. The exact type of parameter is not crucial to the self test feature, nor is it whether the elements are piezo resistive or piezo capacitive, etc. Next at 10-3 a second amount of energy is apply across one or

more piezo-resistive elements 40, 41 while a known pressure is generated in the reservoir. Next at 10-4 a second parameter indicated through the second amount of energy is sensed. At 10-5 the sensed second parameter is calibrated against the preceding known pressure and the quantity of membrane deflection is determined. This, in turn, indicates flow. At 10-6 runs a self diagnosis to determine, among other things, whether the sensed flow is within a predetermined range, if not, then the device closes a valve and shuts down. Otherwise the device uses the new data to correct the sensed deflection against the known pressure and create a new baseline for future measurements.

Although a specific embodiment of the invention has been disclosed, this is done for purposes of illustration and is not intended to be limiting with regard to the scope of the invention. It is contemplated various substitutions, alterations and/or modifications may be made to the disclosed embodiment without departing from the spirit and scope of the invention. Such modifications may include substituting elements or components which perform substantially the same function in substantially the same way to achieve substantially the same result for those described herein.

What is claimed is:

1. An implantable drug infusion device comprising:
5 a hermetic enclosure;
a fluid reservoir positioned within the hermetic enclosure, the fluid reservoir having means for maintaining the fluid therein within a first pressure and a second pressure; the fluid reservoir having an fluid outlet port;
means for delivering a fluid into a patient's body; and
10 a flow regulator coupled to the fluid outlet port, the flow regulator coupled to the means for delivering a fluid into a patient's body the flow regulator having a fluid pathway between the fluid outlet port and the means for delivering a fluid into a patient's body, the flow regulator further having means for permitting fluid to flow within the fluid pathway when the fluid in the reservoir is at a pressure which is more
15 than the first pressure and less than the second pressure.
2. An implantable drug infusion device according to claim 1 wherein the flow regulator comprises a membrane, a shoulder and a bottom layer, the membrane having a hole, whereby the fluid pathway is defined from above the membrane, through the
20 hole and along the bottom layer, whereby flow through the hole causes the membrane to deflect and engage the bottom layer thereby impeding the fluid pathway.
3. An implantable drug infusion device according to claim 2 further comprising a
25 membrane deflected by fluid flow within the fluid pathway.
4. An implantable drug infusion device according to claim 3 further comprising the membrane cantilevered from the shoulder over the bottom layer,
5. An implantable drug infusion device according to claim 4 further comprising
30 means for determining any deflection in the membrane.

6. An implantable drug infusion device according to claim 5 wherein the membrane further includes means for sensing the deflection of the membrane.

5 7. An implantable drug infusion device according to claim 6 means for calibrating the sensed deflection of the membrane with the rate of fluid flow through the fluid pathway.

10 8. An implantable drug infusion device according to claim 1 wherein the flow regulator comprises a membrane, a shoulder and a bottom layer, the bottom layer having a channel therein, the membrane cantilevered from the shoulder over the bottom layer, the membrane having a hole, whereby the fluid pathway is defined from above the membrane, through the hole and along the bottom layer, whereby flow through the hole causes the membrane to deflect and engage the bottom layer thereby
15 permitting the fluid pathway to only exist within the channel.

9. An implantable drug infusion device according to claim 1 further comprising means for varying the length of the flow channel.

20 10. An implantable drug infusion device comprising:
a hermetic enclosure;
a fluid reservoir positioned within the hermetic enclosure, the fluid reservoir having an fluid outlet port;
means for delivering a fluid into a patient's body; and
25 a flow regulator coupled to the fluid outlet port, the flow regulator coupled to the means for delivering a fluid into a patient's body the flow regulator having a fluid pathway between the fluid outlet port and the means for delivering a fluid into a patient's body, the flow regulator having a membrane, a shoulder and a bottom layer, the membrane cantilevered from the shoulder over the bottom layer, the membrane
30 having a hole, whereby the fluid pathway is defined from above the membrane,

through the hole and along the bottom layer, whereby flow through the hole causes the membrane to deflect and engage the bottom layer thereby impeding the fluid pathway.

- 5 11. An implantable drug infusion device according to claim 10 wherein the bottom layer having a channel therein, whereby flow through the hole causes the membrane to deflect and engage the bottom layer thereby permitting the fluid pathway to only exist within the channel.
- 10 12. An implantable drug infusion device according to claim 11 wherein the membrane further includes means for sensing the deflection of the membrane.
13. An implantable drug infusion device according to claim 12 means for calibrating the sensed deflection of the membrane with the rate of fluid flow through the fluid pathway.
- 15 14. An implantable drug infusion device according to claim 10 wherein the flow regulator comprises a membrane, a shoulder and a bottom layer, the bottom layer having a channel therein, the membrane having a hole, whereby the fluid pathway is defined from above the membrane, through the hole and along the bottom layer, whereby flow through the hole causes the membrane to deflect and engage the bottom layer thereby permitting the fluid pathway to only exist within the channel.
- 20 15. An implantable drug infusion device according to claim 10 further comprising means for varying the length of the flow channel.
- 25 16. An implantable drug infusion device comprising:
 a hermetic enclosure;

a fluid reservoir positioned within the hermetic enclosure, the fluid reservoir having means for maintaining the fluid therein within a first pressure and a second pressure; the fluid reservoir having an fluid outlet port;

means for delivering a fluid into a patient's body;

5 a flow regulator coupled to the fluid outlet port, the flow regulator coupled to the means for delivering a fluid into a patient's body the flow regulator having a fluid pathway between the fluid outlet port and the means for delivering a fluid into a patient's body, the flow regulator further having means for permitting fluid to flow within the fluid pathway when the fluid in the reservoir is at a pressure which is more than the first pressure and less than the second pressure; and

10

means for sensing the rate of fluid flow through the flow regulator:

17. An implantable drug infusion device according to claim 16 wherein the means for sensing the rate of fluid flow through the flow regulator:

15

comprises a membrane deflected by fluid flow within the fluid pathway.

18. An implantable drug infusion device according to claim 17 further comprising means for determining any deflection in the membrane.

20

19. An implantable drug infusion device according to claim 18 further comprising means for calibrating any deflection in the membrane against a predetermined fluid pressure in the reservoir.

20. An implantable drug infusion device comprising

25

a hermetic enclosure;

a fluid reservoir positioned within the hermetic enclosure, the fluid reservoir having means for maintaining the fluid therein within a first pressure and a second pressure; the fluid reservoir having an fluid outlet port;

means for delivering a fluid into a patient's body;

a flow regulator coupled to the fluid outlet port, the flow regulator coupled to the means for delivering a fluid into a patient's body the flow regulator having a fluid pathway between the fluid outlet port and the means for delivering a fluid into a patient's body, the flow regulator further having means for permitting fluid to flow
5 within the fluid pathway when the fluid in the reservoir is at a pressure which is more than the first pressure and less than the second pressure; and
means for sensing the flow through the flow regulator.

21. An implantable drug infusion device according to claim 20 further comprising
10 means for calibrating the means for sensing the flow through the flow regulator.

22. An implantable drug infusion device according to claim 21 wherein the means for sensing comprise a deflectable membrane, the membrane have one or more elements indicating membrane deflection.

23. An implantable drug infusion device according to claim 22 further comprising
15 means apply a first amount of energy is applied across one or more elements;
means for sensing a parameter indicated through the first amount of energy applied across one or more elements
20 means for generating a known pressure in the reservoir
means for applying a second amount of energy across one or more elements while a know pressure is generated in the reservoir
means for sensing a second parameter indicated through the second amount of energy;
25 means for calibrating sensed second parameter against the preceding known pressure and determine quantity of membrane deflection

24. An implantable drug infusion device according to claim 20 further comprising
30 means for determining any deflection in the membrane caused by a pressure to the fluid in the reservoir and adjusting the determined deflection to compensate for any

changes in the membrane shape to thereby provide a measure of fluid flow through the flow regulator.

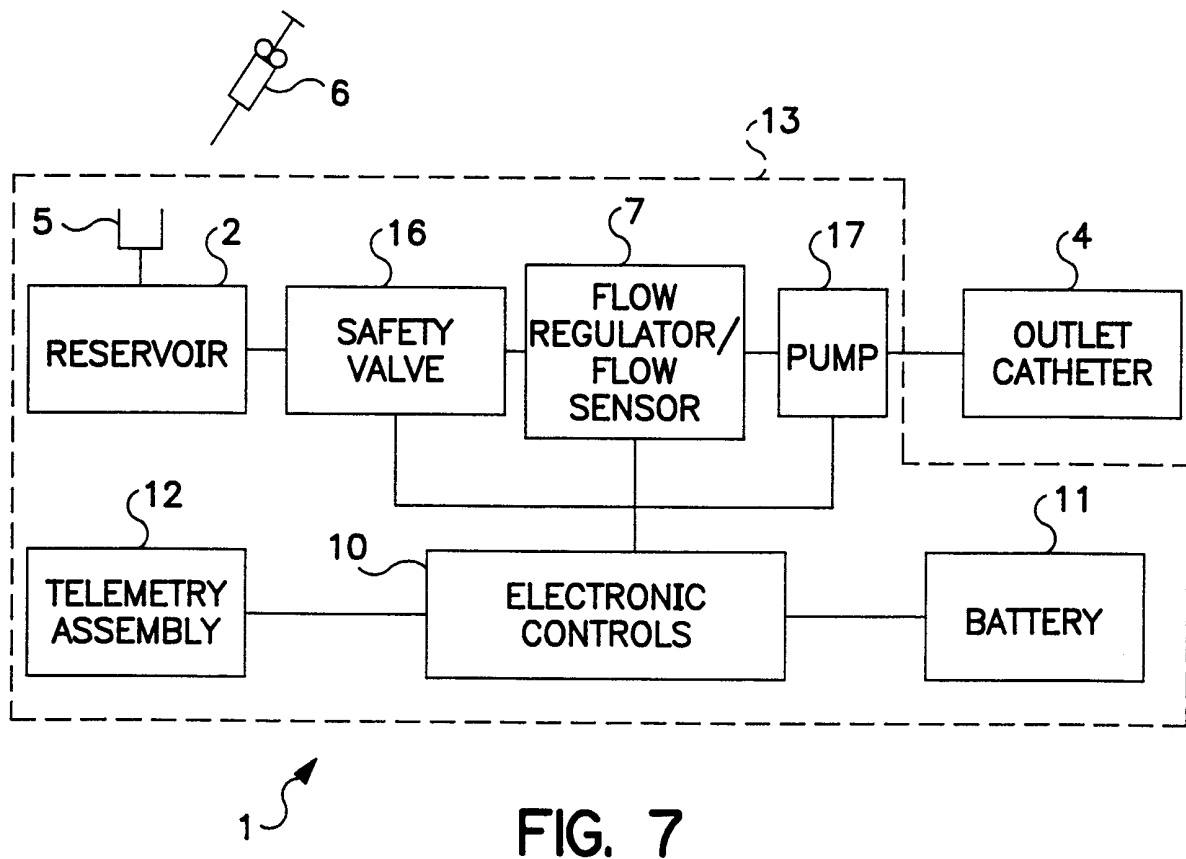
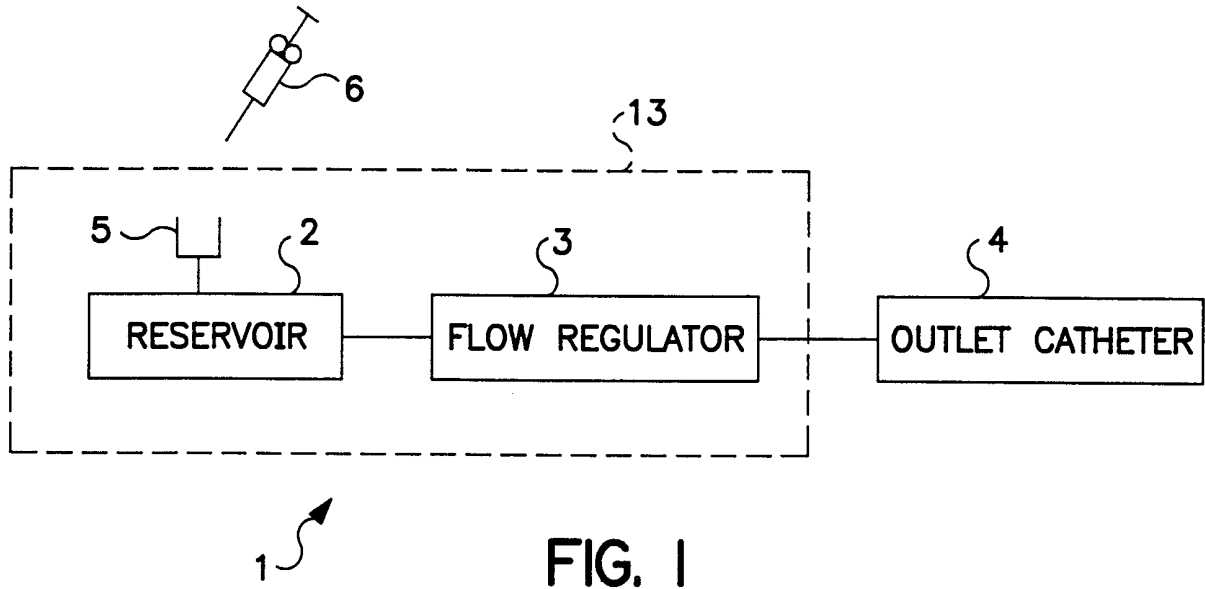

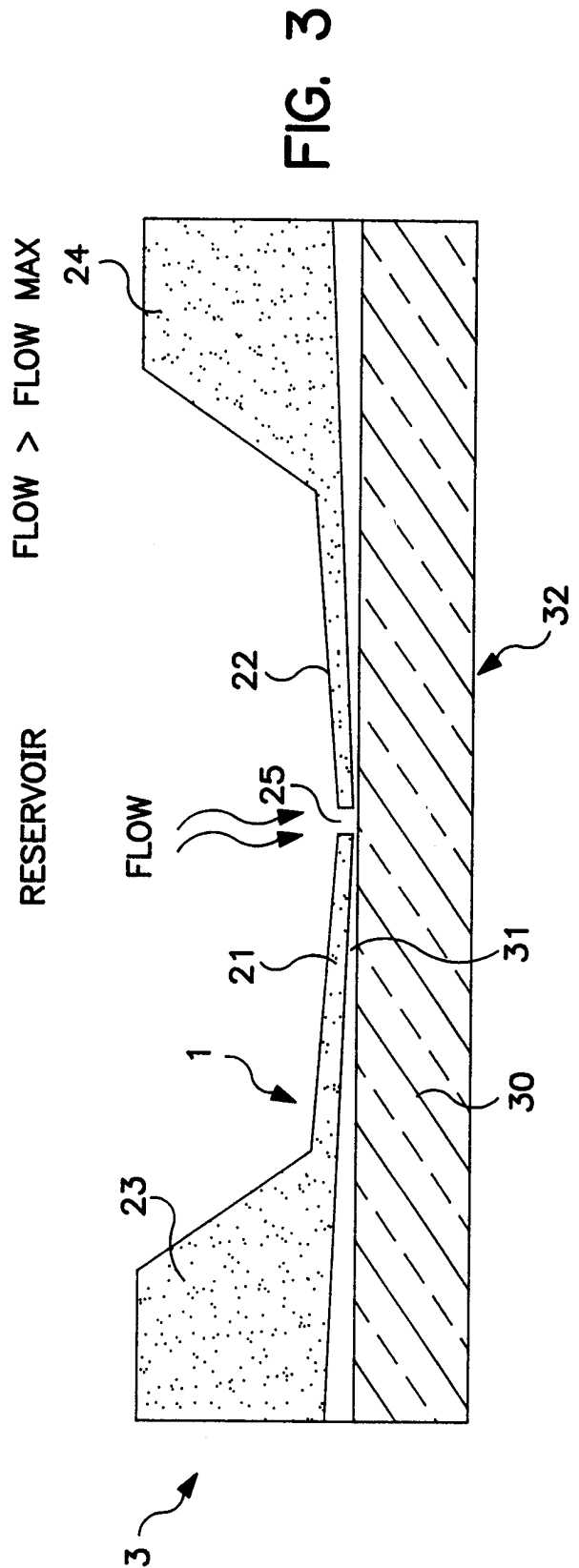
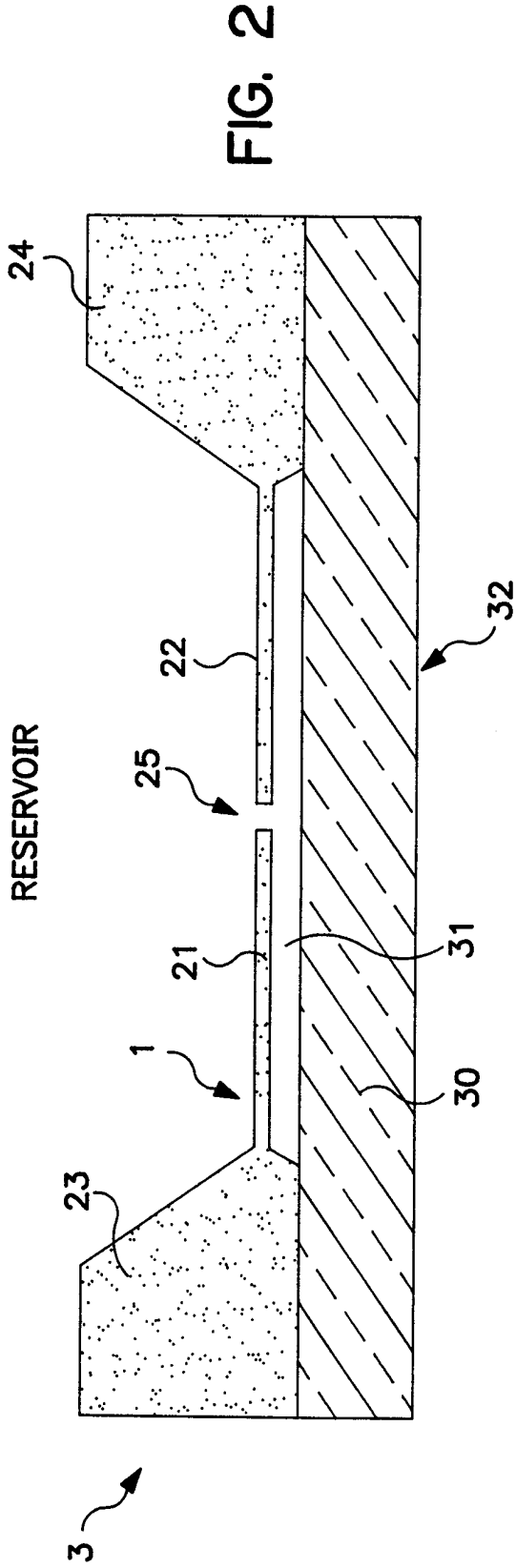

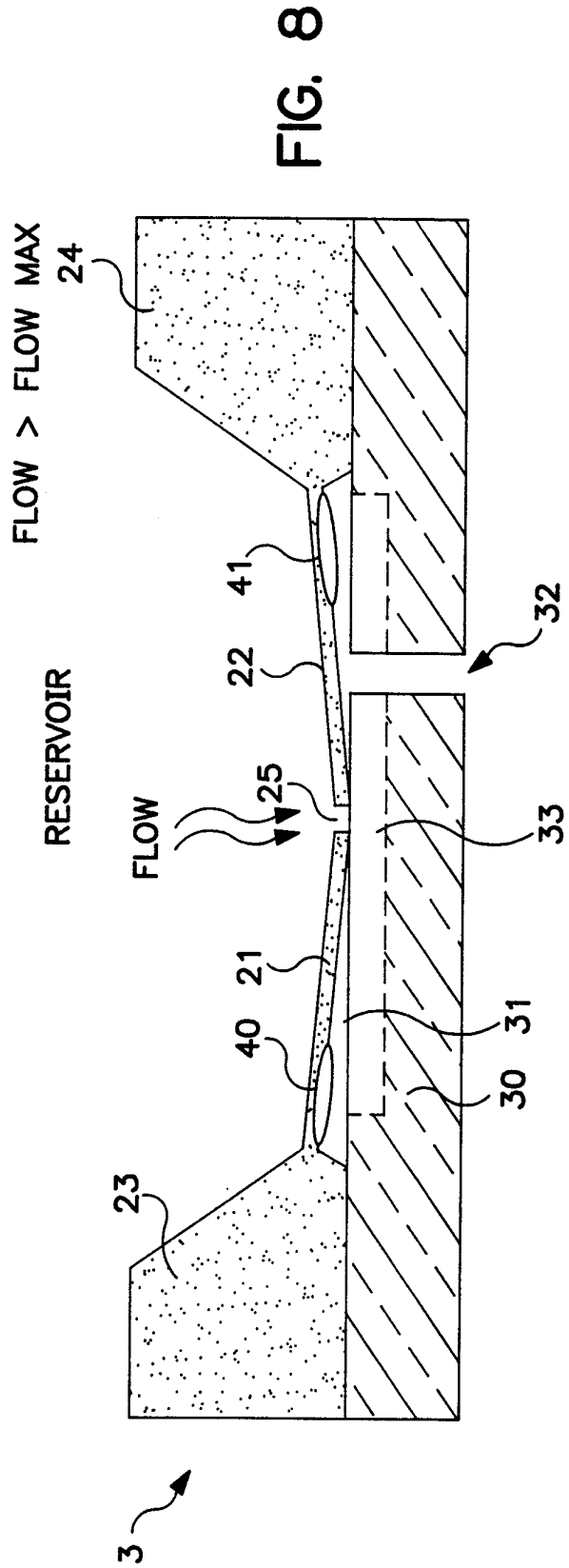
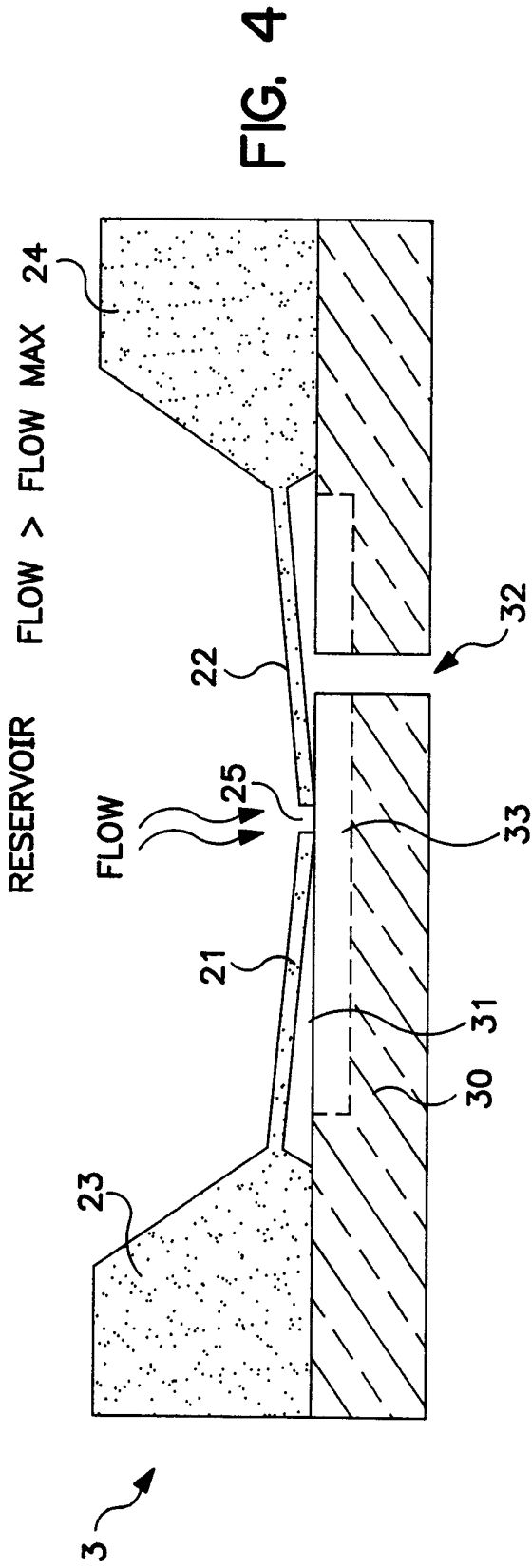

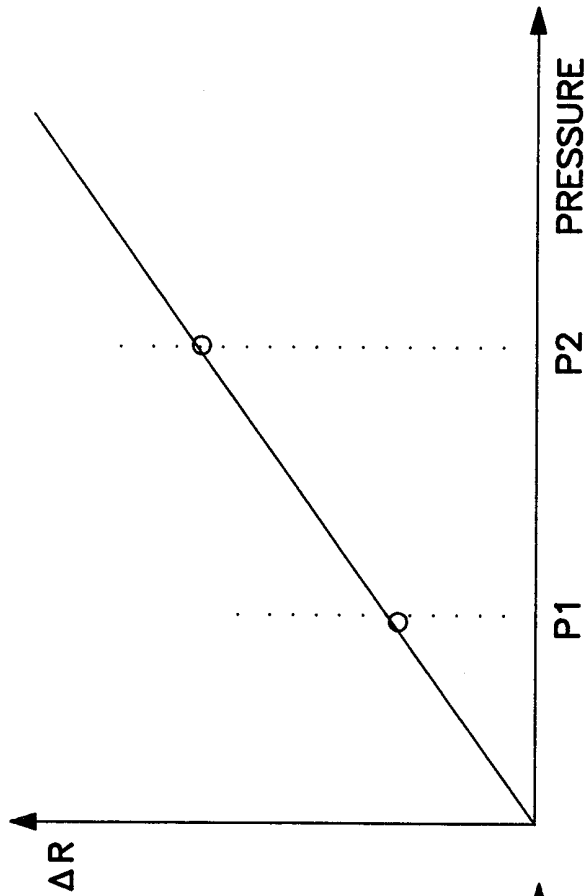

FIG. 9

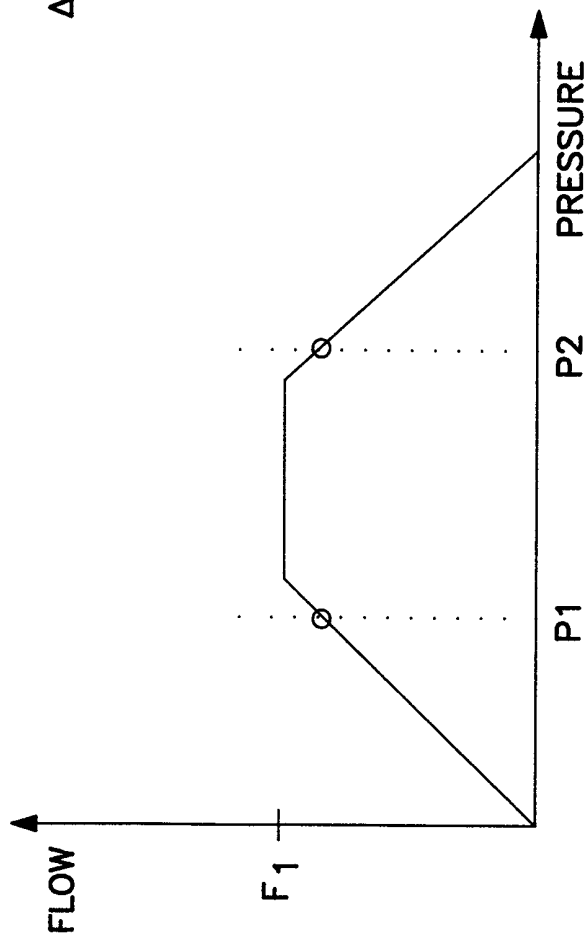

FIG. 6

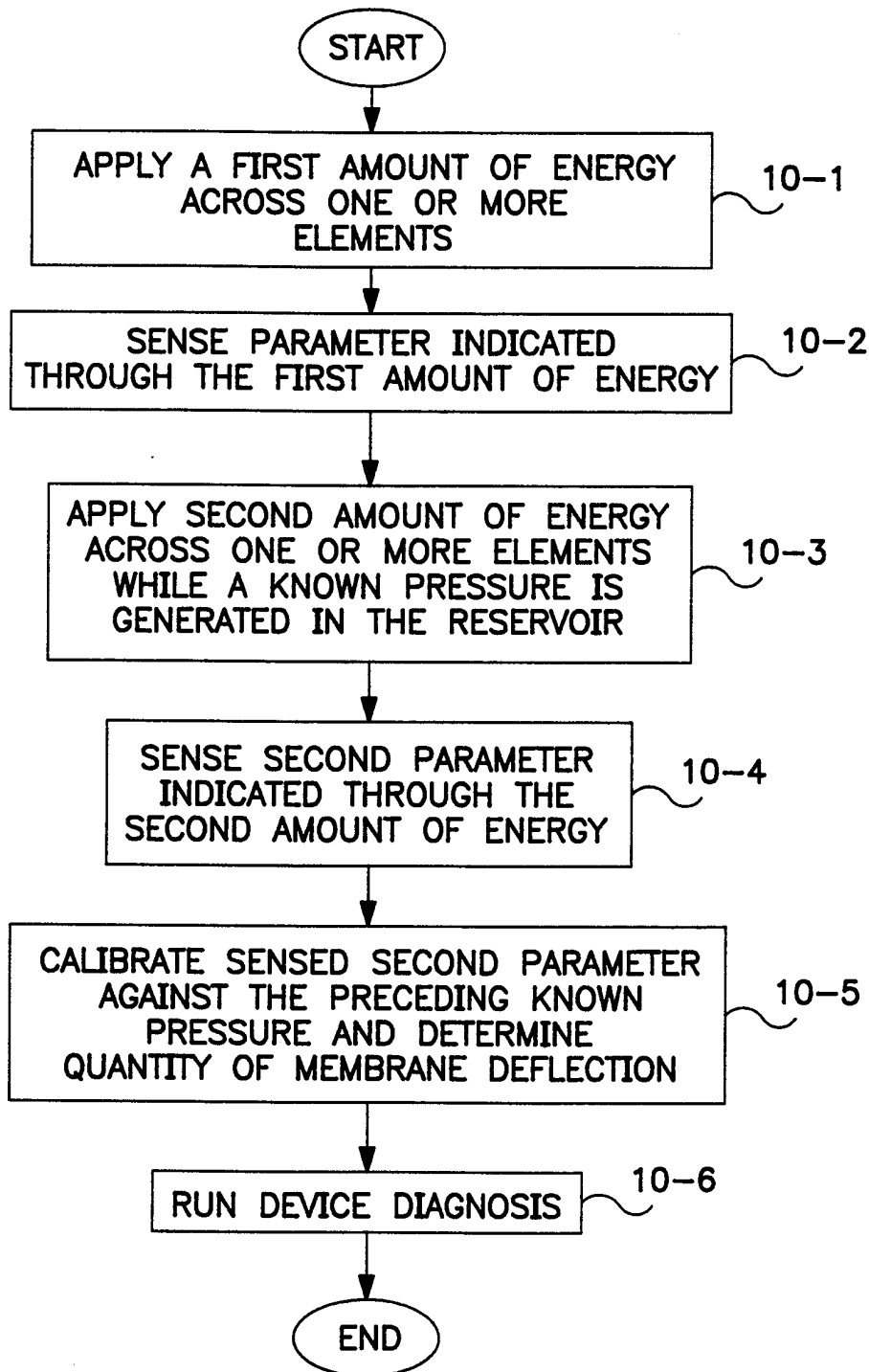

FIG. 10

INTERNATIONAL SEARCH REPORT

International Application No

PCT/US 99/02136

A. CLASSIFICATION OF SUBJECT MATTER
 IPC 6 A61M5/142 A61M5/168 G05D7/01

According to International Patent Classification (IPC) or to both national classification and IPC

B. FIELDS SEARCHED
 Minimum documentation searched (classification system followed by classification symbols)
 IPC 6 A61M G05D

Documentation searched other than minimum documentation to the extent that such documents are included in the fields searched

Electronic data base consulted during the international search (name of data base and, where practical, search terms used)

C. DOCUMENTS CONSIDERED TO BE RELEVANT

Category °	Citation of document, with indication, where appropriate, of the relevant passages	Relevant to claim No.
X	EP 0 409 511 A (INFUSAID INC.) 23 January 1991 see column 2, line 29 - column 4, line 32 see figures 1,2	1
Y	---	2-4, 10
Y	FR 1 299 719 A (SOCIÉTÉ ANONYME ANDRÉ CITROEN) 12 December 1962 see page 1, column 2, line 4 - page 2, column 1, line 13 see figure 1	2-4, 10
A	---	8, 9, 11, 14, 15
	-/-	

Further documents are listed in the continuation of box C.

Patent family members are listed in annex.

° Special categories of cited documents :

- "A" document defining the general state of the art which is not considered to be of particular relevance
- "E" earlier document but published on or after the international filing date
- "L" document which may throw doubts on priority claim(s) or which is cited to establish the publication date of another citation or other special reason (as specified)
- "O" document referring to an oral disclosure, use, exhibition or other means
- "P" document published prior to the international filing date but later than the priority date claimed

- "T" later document published after the international filing date or priority date and not in conflict with the application but cited to understand the principle or theory underlying the invention
- "X" document of particular relevance; the claimed invention cannot be considered novel or cannot be considered to involve an inventive step when the document is taken alone
- "Y" document of particular relevance; the claimed invention cannot be considered to involve an inventive step when the document is combined with one or more other such documents, such combination being obvious to a person skilled in the art.
- "&" document member of the same patent family

Date of the actual completion of the international search 4 May 1999	Date of mailing of the international search report 14/05/1999
--	---

Name and mailing address of the ISA European Patent Office, P.B. 5818 Patentlaan 2 NL - 2280 HV Rijswijk Tel. (+31-70) 340-2040, Tx. 31 651 epo nl, Fax: (+31-70) 340-3016	Authorized officer Schönleben, J
--	--

INTERNATIONAL SEARCH REPORT

International Application No

PCT/US 99/02136

C.(Continuation) DOCUMENTS CONSIDERED TO BE RELEVANT		
Category °	Citation of document, with indication, where appropriate, of the relevant passages	Relevant to claim No.
X	GB 2 127 179 A (INFUSAID CORP.) 4 April 1984 see page 3, line 117 - page 4, line 111 see page 6, line 79 - page 7, line 53 see figures 1,3 ---	16,20
X	WO 80 02377 A (REGENTS OF THE UNIVERSITY OF MINNESOTA) 13 November 1980 see page 2, line 10 - page 3, line 3 see figure 1 ---	1
A	EP 0 398 583 A (BESPAK PLC) 22 November 1990 see column 9, line 3 - line 26 see figures 4-7 ---	5-7,12, 13, 17-19, 21,22,24
A	US 4 428 397 A (BRON) 31 January 1984 see abstract see figure 1 -----	2-4

INTERNATIONAL SEARCH REPORT

Information on patent family members

Intern. Application No

PCT/US 99/02136

Patent document cited in search report	Publication date	Patent family member(s)	Publication date
EP 409511 A	23-01-1991	US 5061242 A	29-10-1991
		AT 102488 T	15-03-1994
		AU 620527 B	20-02-1992
		AU 5912890 A	31-01-1991
		CA 2021284 A, C	19-01-1991
		DE 69007194 D	14-04-1994
		DE 69007194 T	16-06-1994
		DK 409511 T	05-04-1994
		ES 2050957 T	01-06-1994
		JP 1752887 C	23-04-1993
		JP 3068373 A	25-03-1991
JP 4036033 B	12-06-1992		
FR 1299719 A	12-12-1962	NONE	
GB 2127179 A	04-04-1984	US 4447224 A	08-05-1984
		CA 1192464 A	27-08-1985
		DE 3333977 A	22-03-1984
		JP 59075055 A	27-04-1984
WO 8002377 A	13-11-1980	US 4299220 A	10-11-1981
		AR 219667 A	29-08-1980
		AT 7269 T	15-05-1984
		AU 535284 B	08-03-1984
		AU 6053680 A	20-11-1980
		BE 883100 A	03-11-1980
		BR 8008671 A	14-04-1981
		CA 1152823 A	30-08-1983
		DK 581 A, B,	02-01-1981
		EP 0028250 A	13-05-1981
		FR 2455466 A	28-11-1980
		JP 1026303 B	23-05-1989
		JP 56500440 T	09-04-1981
		ZA 8002636 A	27-05-1981
EP 398583 A	22-11-1990	AT 103823 T	15-04-1994
		AU 635262 B	18-03-1993
		AU 5486590 A	15-11-1990
		CA 2016595 A, C	11-11-1990
		CN 1047368 A, B	28-11-1990
		DE 69007855 D	11-05-1994
		DE 69007855 T	28-07-1994
		IE 64119 B	12-07-1995
		JP 1909888 C	09-03-1995
		JP 3001876 A	08-01-1991
		JP 6034824 B	11-05-1994
		PT 94017 A	08-01-1991
US 5205819 A	27-04-1993		
US 4428397 A	31-01-1984	AR 216110 A	30-11-1979
		AU 502903 B	09-08-1979
		AU 2984277 A	26-04-1979
		BR 7707506 A	20-06-1978
		CA 1065736 A	06-11-1979
		DE 2748055 A	11-05-1978
		FR 2369615 A	26-05-1978
		GB 1567988 A	21-05-1980
		GR 71666 A	20-06-1983

INTERNATIONAL SEARCH REPORT

Information on patent family members

International Application No

PCT/US 99/02136

Patent document cited in search report	Publication date	Patent family member(s)	Publication date
US 4428397 A		JP 1694538 C	17-09-1992
		JP 3059712 B	11-09-1991
		JP 57203451 A	13-12-1982
		JP 53055526 A	20-05-1978
		NL 7711461 A,B,	02-05-1978
		PT 67189 A,B	01-11-1977
		ZA 7706121 A	30-08-1978
