

No. 672,575.

Patented Apr. 23, 1901.

G. SWINEHART.
DRAFT ATTACHMENT FOR VEHICLES.

(Application filed Dec. 6, 1900.)

(No Model.)

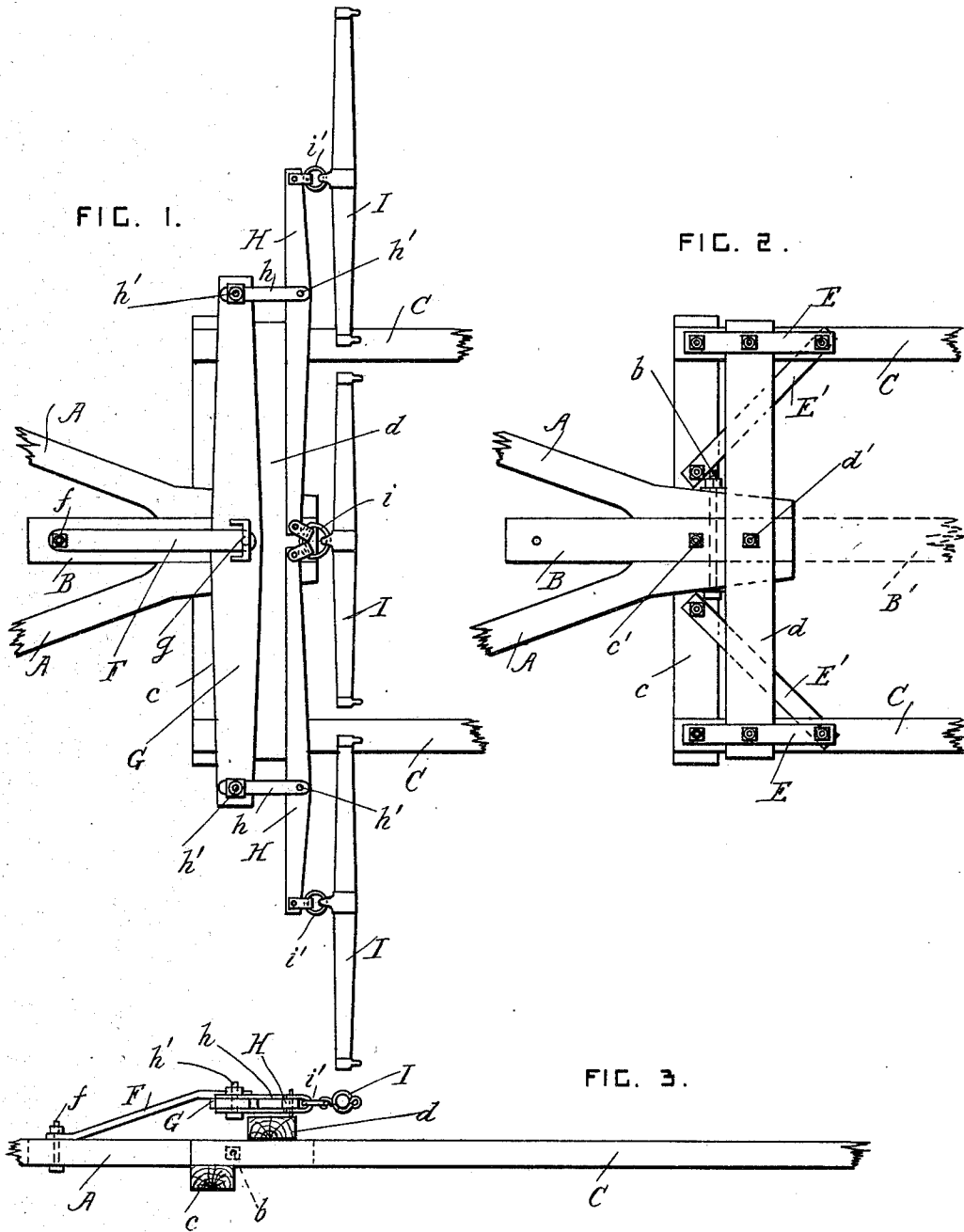

WITNESSES
J. D. Spang Pooler
Walter Allen

INVENTOR
George Swinehart.
by Herbert W. Jenner.
Attorney

UNITED STATES PATENT OFFICE.

GEORGE SWINEHART, OF GLENFORD, OHIO, ASSIGNOR OF ONE-HALF TO CHARLES H. ICE, OF SAME PLACE.

DRAFT ATTACHMENT FOR VEHICLES.

SPECIFICATION forming part of Letters Patent No. 672,575, dated April 23, 1901.

Application filed December 6, 1900. Serial No. 38,920. (No model.)

To all whom it may concern:

Be it known that I, GEORGE SWINEHART, a citizen of the United States, residing at Glenford, in the county of Perry and State of Ohio, have invented certain new and useful Improvements in Draft Attachments for Vehicles; and I do hereby declare the following to be a full, clear, and exact description of the invention, such as will enable others skilled in the art to which it appertains to make and use the same.

This invention relates to draft attachments for vehicles; and it consists in the novel construction and combination of the parts hereinafter fully described and claimed.

In the drawings, Figure 1 is a plan view of the draft attachment, showing the three-horse equalizer in position. Fig. 2 is a similar view with the equalizer removed. Fig. 3 is a side view of the parts shown in Fig. 2.

A A are portions of the two side bars or futchells of a platform-gear of any approved construction.

B is a short tongue which is clamped between the bars A A by means of a single bolt *b*.

When the vehicle is to be drawn by two horses, the short tongue B is removed and a vehicle-pole of approved form is clamped in its place, as indicated by the dotted lines B' in Fig. 2.

C represents the shafts, which are used when one or three horses are to be harnessed to the vehicle. When two horses are used, the shafts C, together with the short tongue B, to which they are rigidly attached, are dispensed with, as the long pole B' serves the same purpose as the shafts C and is secured between the bars A instead of the tongue B, with which it is interchangeable. A lower cross-bar *c* is secured to the under sides of the rear end portions of the shafts C and extends under the tongue B and bars A. This cross-bar *c* is secured to the tongue B by a bolt *c'*. An upper cross-bar *d* is secured to the upper sides of the end portions of the shafts in front of the cross-bar *c* and extends over the tongue and bars A. The cross-bar *c* is secured to the tongue B by a bolt *d'*.

E represents strap-plates which assist in securing the cross-bar *d* to the shafts, and E'

represents braces which assist in connecting the shafts to the cross-bar *c*.

A single horse can be harnessed to the vehicle when the parts are arranged as shown in full lines in Fig. 2.

When three horses are to be harnessed to the vehicle, the equalizer shown in Fig. 1 is used.

F is a draft-bar, which is pivoted by a pin *f* to the rear end portion of the short tongue B.

G is a bar, which is pivoted by a pin *g* at the middle of its length to the front end portion of the draft-bar F.

H represents levers having end portions of unequal length. Liuks *h* are pivoted to the levers H and to the end portions of the bar G by pins *h'*.

I represents three whiffletrees. One of these whiffletrees is pivotally connected to two adjacent end portions of the longer parts of the levers H by connections *i*. The other two whiffletrees are pivotally connected by suitable connections *i'* to the shorter end portions of the levers H, which project over the shafts. The horses are harnessed to the whiffletrees in the usual manner. The bar G rests upon the upper cross-bar, which supports it in a horizontal plane, but otherwise permits it to move in every direction.

These draft attachments can be changed very quickly, according to the load in the vehicle, and they are simple, inexpensive to make, and not liable to get out of order.

What I claim is—

1. In a draft attachment, the combination, with the side bars of a platform-gear, a removable tongue, and means for clamping the said tongue between the said side bars; of a pair of shafts, and upper and lower cross-bars secured to the said shafts and tongue and bearing respectively against the upper and under sides of the said side bars, said tongue forming the connection between the cross-bars of the said shafts and the side bars of the platform-gear, substantially as set forth.

2. In a draft attachment, the combination, with the side bars of a platform-gear, a removable tongue, and means for clamping the said tongue between the said side bars; of a pair of shafts secured to the said tongue, a

draft-bar pivoted to the rear part of the said tongue, a bar pivoted centrally to the draft-bar over the front part of the said tongue, levers having end portions of unequal length, links 5 pivoted to the said levers and to the end portions of the said bar, a whiffletree pivoted to the adjacent and longer end portions of the said levers, and whiffletrees pivoted to the

shorter end portions of the said levers, substantially as set forth. 10

In testimony whereof I affix my signature in presence of two witnesses.

GEORGE SWINEHART.

Witnesses:

S. P. SWINEHART,
C. H. ICE.