



INTERNATIONAL APPLICATION PUBLISHED UNDER THE PATENT COOPERATION TREATY (PCT)

<p>(51) International Patent Classification⁶ : A61B 5/00</p>	<p>A1</p>	<p>(11) International Publication Number: WO 99/39632 (43) International Publication Date: 12 August 1999 (12.08.99)</p>
<p>(21) International Application Number: PCT/US99/02594 (22) International Filing Date: 5 February 1999 (05.02.99) (30) Priority Data: 60/073,890 6 February 1998 (06.02.98) US (71)(72) Applicants and Inventors: EVANS, David, K. [US/US]; 10731 Chase Court, Fishers, IN 46038 (US). BRINKERHOFF, Ronald, J. [US/US]; 3030 Twin Ridge Drive, New Richmond, OH 45157 (US). KATZ, Hal, H. [US/US]; 7903 Woodglen Drive, West Chester, OH 45069 (US). KRAIMER, William, J. [US/US]; 8037 Buckland Drive, Cincinnati, OH 45249 (US). (74) Agents: HENRY, Thomas, Q. et al.; Woodard, Emhardt, Naughton, Moriarty & McNett, Bank One Center/Tower, Suite 3700, 111 Monument Circle, Indianapolis, IN 46204 (US).</p>		<p>(81) Designated States: AU, CA, JP, European patent (AT, BE, CH, CY, DE, DK, ES, FI, FR, GB, GR, IE, IT, LU, MC, NL, PT, SE). Published <i>With international search report. Before the expiration of the time limit for amending the claims and to be republished in the event of the receipt of amendments.</i></p>

(54) Title: DEVICE FOR VISUALIZING, DISSECTING AND HARVESTING VESSELS

(57) Abstract

A device useful in minimally invasive procedures involving the visualization, dissection, and/or harvesting of vessels in the body, includes a shaft (11) having a handle (12) mounted on one end, and a dissecting tip (13) on the other end. The dissecting tip optionally includes a light source (18) for directing light transverse of the tip (13), and structures to retain the tip in position adjacent the vessel as the tip (13) is advanced along the vessel.

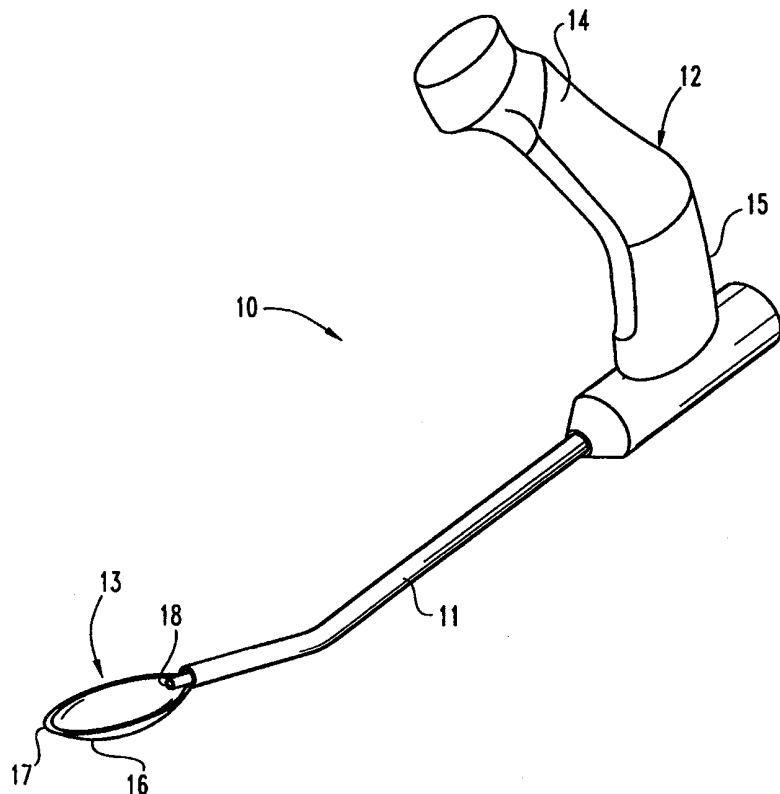

FOR THE PURPOSES OF INFORMATION ONLY

Codes used to identify States party to the PCT on the front pages of pamphlets publishing international applications under the PCT.

AL	Albania	ES	Spain	LS	Lesotho	SI	Slovenia
AM	Armenia	FI	Finland	LT	Lithuania	SK	Slovakia
AT	Austria	FR	France	LU	Luxembourg	SN	Senegal
AU	Australia	GA	Gabon	LV	Latvia	SZ	Swaziland
AZ	Azerbaijan	GB	United Kingdom	MC	Monaco	TD	Chad
BA	Bosnia and Herzegovina	GE	Georgia	MD	Republic of Moldova	TG	Togo
BB	Barbados	GH	Ghana	MG	Madagascar	TJ	Tajikistan
BE	Belgium	GN	Guinea	MK	The former Yugoslav Republic of Macedonia	TM	Turkmenistan
BF	Burkina Faso	GR	Greece	ML	Mali	TR	Turkey
BG	Bulgaria	HU	Hungary	MN	Mongolia	TT	Trinidad and Tobago
BJ	Benin	IE	Ireland	MR	Mauritania	UA	Ukraine
BR	Brazil	IL	Israel	MW	Malawi	UG	Uganda
BY	Belarus	IS	Iceland	MX	Mexico	US	United States of America
CA	Canada	IT	Italy	NE	Niger	UZ	Uzbekistan
CF	Central African Republic	JP	Japan	NL	Netherlands	VN	Viet Nam
CG	Congo	KE	Kenya	NO	Norway	YU	Yugoslavia
CH	Switzerland	KG	Kyrgyzstan	NZ	New Zealand	ZW	Zimbabwe
CI	Côte d'Ivoire	KP	Democratic People's Republic of Korea	PL	Poland		
CM	Cameroon	KR	Republic of Korea	PT	Portugal		
CN	China	KZ	Kazakstan	RO	Romania		
CU	Cuba	LC	Saint Lucia	RU	Russian Federation		
CZ	Czech Republic	LI	Liechtenstein	SD	Sudan		
DE	Germany	LK	Sri Lanka	SE	Sweden		
DK	Denmark	LR	Liberia	SG	Singapore		
EE	Estonia						

DEVICE FOR VISUALIZING, DISSECTING AND HARVESTING VESSELS

5

BACKGROUND OF THE INVENTION

10 Field of the Invention:

The present invention relates to new, efficient, minimally-invasive methods and devices for visualizing, dissecting and/or harvesting blood vessels and the like.

Description of the Prior Art:

15 In many cases it is desirable to visualize a section of a blood vessel of the body, and in some instances to remove the vessel, possibly as a replacement for a defective or diseased portion of a blood vessel in another part of the body. For example, damage to or occlusion of coronary arteries is frequently remedied by using a vessel from another location as graft material in a coronary artery bypass grafting procedure. The saphenous vein has been commonly used as the grafting material in this procedure.

20 Conventional methods of removing a vessel from a patient involve an open surgical procedure whereby an incision is made along the length of the vessel desired to be harvested. For example, when harvesting the saphenous vein, a large incision is made along the interior length of the patient's leg (from groin to knee, knee to ankle or ankle to groin). This procedure can result in significant post-operative pain and wound site
25 complications such as hematoma, wound infection and delayed healing. Cosmetically undesirable scars remain behind as well.

Efforts to overcome the drawbacks of the conventional methods have led to the development of several minimally invasive methods. For example, Mindich discloses the use of an elongated plastic tube having at least one knife blade mounted on its distal
30 end to harvest a section of vein. U.S. Patent No. 4,793,346 (1988). The knife blade can be heated by supplying current through electrical conductors extending the length of the tube. The disclosed process comprises making two different incisions in the body of a

-2-

patient, one at either end of the desired vein. The vein is then severed at each end, one end of the vein is inserted into the tube, and the tube is advanced along the length of the vein. The rotating knife blades sever any side branches that are present and cauterize the severed ends.

5 Several endoscopic procedures have attempted to improve upon the minimally invasive vessel harvesting procedures. For example, Knighton describes the use of an endoscope having a lumen extending longitudinally along its body to harvest a section of a blood vessel from a patient through an incision. U.S. Patent No. 5,378,840 (1994). The blood vessel is transected at its proximal end, a grasping instrument is inserted
10 through the lumen of the endoscope in order to hold the proximal end of the vessel in place, and the endoscope is advanced along the length of the vessel until the desired length of vessel is obtained. When branch points are reached, they are ligated and cut with a ligation-cutting tool introduced through the lumen of the endoscope. The blood vessel is then severed at its distal end and the vessel, within the lumen of the endoscope,
15 is removed from the body.

 When used to harvest the saphenous vein, the side branches of the vein limit the maneuverability of the endoscope since the outer edge of the endoscope body is prevented from advancing along the trunk of the saphenous vein until the encountered side branches are ligated and transected. Moreover, this method may require several
20 hands and thus more than one individual. One hand is required to hold and maintain the endoscope in position, a second hand is required to hold the free end of the transected vessel with a grasper, and a third hand is required to dissect connective tissue away from the vessel.

 Fogarty et al. teach a method and device for blood vessel harvesting utilizing an
25 endoscope and a side-hooked wire. U.S. Patent No. 5,601,581 (1997). A working space is first created along, for example, the saphenous vein by making small incisions near the

-3-

knee and groin, inserting a blunt tunneling tool into one incision, and pushing the tool towards the other incision. The tunnel can be further expanded with a balloon dissector. The incisions are sealed and a gas such as carbon dioxide is introduced into the tunnel. A side-hooked wire is then introduced and is used to pry the vein from its connective
5 tissue. Side branches are detected when resistance is felt while pulling the hooked wire. The side branches are then visualized with the endoscope and the branches are ligated and severed.

Knight teaches the use of an optical dissector and an optical retractor to endoscopically harvest a blood vessel. U.S. Patent No. 5,667,480 (1997). The optical
10 dissector comprises a shaft with a lumen extending longitudinally along its length and containing an endoscope. The end of the dissector is comprised of a spoon-shaped working head that can bluntly dissect subcutaneous tissue. The retractor also has a spoon-shaped working head that allows instrumentation such as dissectors, ligators and cutting devices to be inserted into the working space.

15 In harvesting a saphenous vein using this procedure, a small incision is made in the patient's leg near the vessel. The optical dissector is introduced through the incision to dissect tissue away from the superior surface of the vessel. The optical retractor is then used to retract dissected tissue away from the vessel and allows for passage of a vessel dissector to dissect connective tissue from the vein. The course of both the dissection
20 and the retraction is visualized with the attached endoscope. Side branches are dissected, ligated and transected as necessary and the vessel is removed with endoscopic graspers through the incision.

Although this procedure is minimally invasive, there is room for improvement. Significantly, a longer period of time is required to complete the procedure compared to
25 other techniques. For example, whereas the open surgical technique requires approximately 35 minutes to perform, this endovascular harvesting technique may

-4-

require as much as 1.5 hours for inexperienced individuals, with the average time being 40-60 minutes. Any increased procedure time could also increase the likelihood of infection. Further, this method can require a significant amount of training time (e.g., five to ten cases) to adjust the surgeon's hand-eye coordination in using an endoscope.

5 Trauma to the patient is more likely to occur due to the difficulty in developing this skill. Finally, this method requires a significant amount of space in the operating room due to the number of assistants that are needed as well as the presence of the bulky videoscopic equipment. All of these factors add to the increased risk to the patient and increased costs associated with this procedure.

10 There has therefore remained a need for a cost effective technique for harvesting a blood vessel that is minimally invasive, reduces the likelihood of damage to the vessel to be harvested, allows for more direct monitoring of the vessel to be harvested, uses space efficiently, requires less training, and reduces the possibility of injury to the patient and concomitant patient morbidity.

SUMMARY OF THE INVENTION

Briefly describing one aspect of the present invention, there is provided a device
5 useful for visualizing, dissecting and/or harvesting a vessel or similar structure of the
body. The device includes a shaft having a handle attached to the proximal end and a
dissecting tip attached to the distal end. In one embodiment the tip includes a light
source for directing light laterally of the tip. In a method for visualizing a vessel, the tip
and light source are positioned posterior of the vessel and the light transmitted past the
10 vessel and through the skin permits visualization of the vessel from outside of the body.
In another aspect, the dissecting tip includes various retaining structures for retaining the
tip in position adjacent to the vessel as the tip is advanced along the vessel. The tip and
particularly the retaining structures may also be configured to have edges and surfaces
which facilitate dissection of the vessel from the surrounding tissue and transection of
15 side branches of the vessel.

The invention also provides methods utilizing the foregoing devices to dissect a
vessel or the like from associated tissue, and optionally to remove the vessel from the
body. Such methods include making an incision in the body adjacent the vessel,
inserting the dissection device into the body and positioning the vessel within one or
20 more provided retaining structures, and advancing the device along the vessel to dissect
the vessel from surrounding tissue. In addition, the methods may further include
transecting the vessel at selected proximal and distal locations and thereafter removing
the vessel from the body.

It is an object of the present invention to provide methods and devices for
25 minimally-invasive surgical procedures involving the visualization, dissection and/or
harvesting of vessels.

-6-

It is another object of the invention to provide such methods and devices which are simple and inexpensive in construction, easily used with reduced training requirements, and provide superior operative results for patients.

5 A further object is to provide devices and methods useful for harvesting vessels and the like, for example the saphenous vein, in a quicker and less traumatic fashion, with less equipment and therefore less cost, and which particularly includes minimal skin incisions which are more readily closed and heal more quickly with less pain and fewer complications.

10 Further objects and advantages of the present invention will be apparent from the following description of the preferred embodiments.

BRIEF DESCRIPTION OF THE DRAWINGS

5 FIG. 1 is a perspective view of a device constructed in accordance with the present invention.

 FIG. 2 is a perspective view of a preferred embodiment of a dissecting tip useful in the present invention.

 FIG. 3 is an alternate embodiment of a dissecting tip of the present invention,
10 showing a particular design for including a light source.

 FIG. 4 is a further alternative design of the dissecting tip including a light emitting body.

 FIG. 5 is a perspective view showing the use of the present invention for transilluminating a vessel.

15 FIG. 6 is a top, plan view showing the use of the transillumination feature of the present invention in conjunction with intraluminal tubing placed within the subject vessel.

 FIG. 7 is a perspective view of an embodiment of the dissecting tip showing several retaining structures.

20 FIG. 8 is a side, cross-sectional view of the embodiment of FIG. 6 with a vessel received within the retaining structures.

 FIG. 9 is a front, cross-sectional view of a version of the dissecting tip which includes mutually facing arms for retaining a vessel.

 FIGS. 10 and 11 are perspective views of an alternate embodiment of the dissecting
25 tip showing overlapping retaining arms.

 FIG. 12 is a side, elevational view of the embodiment of FIG. 10.

 FIG. 13 is a front, elevational view of the embodiment of FIG. 10.

FIG. 14 is a top, plan view of the embodiment of FIG. 10.

FIG. 15 is a perspective view of an alternate embodiment of the dissecting tip showing abutting retaining arms.

FIG. 16 is a front, cross-sectional view of the embodiment of FIG. 15, looking
5 backward from in front of the retaining arms.

FIG. 17 is a side, cross-sectional view of the embodiment of FIG. 16.

FIG. 18 is a top, plan view of an embodiment of the dissecting tip including an angled, S-shaped slot between the arms.

FIG. 19 is a side, elevational view of the dissecting tip of FIG. 18.

10 FIG. 20 is a side, cross-sectional view of the dissecting tip of FIG. 18.

FIG. 21 is a front, elevational view of the embodiment of FIG. 18.

FIG. 22 is a perspective view of an embodiment of a dissection tip including monopolar cauterizing arms.

FIG. 23 is a perspective view of an embodiment of a dissection tip including
15 bipolar cauterizing arms.

FIG. 24 is a perspective view of an embodiment of a dissection tip including a monopolar cauterizing arch.

FIG. 25 is a perspective view of an embodiment of a dissection tip including an arcuate shaped lumen in the shaft.

20 FIG. 26 is a perspective view of an embodiment of a dissection tip including a plurality of lumens in the shaft.

FIG. 27 is a perspective view showing the initial insertion of the distal end of a dissecting device in a method of the present invention.

FIG. 28 is a perspective view showing the insertion of the dissecting device prior
25 to encountering a side branch.

FIG. 29 is a perspective view showing the insertion of the dissecting device to a point at which a side branch is encountered.

FIG. 30 is a perspective view showing the insertion of the dissecting device beyond a transected side branch.

-10-

DESCRIPTION OF THE PREFERRED EMBODIMENT

For the purposes of promoting an understanding of the principles of the invention,
5 reference will now be made to the embodiment illustrated in the drawings and specific
language will be used to describe the same. It will nevertheless be understood that no
limitation of the scope of the invention is thereby intended, such alterations and further
modifications in the illustrated device, and such further applications of the principles of
the invention as illustrated therein being contemplated as would normally occur to one
10 skilled in the art to which the invention relates.

The present invention provides instrumentation useful for minimally-invasive
procedures involving the visualization, dissection and/or harvesting of vessels and the
like. The devices and methods are described by way of example in regard to use with
blood vessels, although use also applies with other elongated structures, such as tendons.
15 The basic device includes a shaft having a handle attached to the proximal end and a
dissecting tip attached to the distal end. The handle is configured to facilitate
manipulation of the device for its various intended uses.

The dissecting tip may assume a variety of designs depending on the use. For
example, the inclusion of a light source enables visualization of a vessel through the skin
20 of the body. Positioning the light source posterior of the vessel provides
transillumination of the vessel as the light passes the vessel and associated tissue and can
be viewed from exterior of the body through the skin. In addition, particular retaining
structures may be provided to facilitate movement of the device along a selected vessel,
tendon, etc. Also, auxiliary means are provided as desired to handle other tasks, such as
25 the severing of connective tissue and side branches of the vessel or other structure.

The devices of the present invention are useful in a diversity of specific medical
procedures. A preferred embodiment is described with respect to the visualization and

-11-

harvesting of the saphenous vein. It will be appreciated, however, that the devices and methods are equally suitable to other procedures. In one respect, the inventive method involves the placement of a light source posterior to a selected vessel and the use of light transmitted through the person's skin to visualize the location and structure of the vessel.

5 This transillumination of the vessel is used to assist in guiding the device along the vessel, and particularly in some aspects to dissect the vessel from the surrounding tissue, address the issue of side branches, and ultimately remove the vessel. The devices and methods include retaining structures by which the vessel is positioned relative to the dissecting tip to assist in the movement of the device relative to the vessel. As a

10 consequence of the invention, a minimally-invasive procedure is achieved which is relatively quick and causes reduced trauma as compared to prior art techniques and systems.

A preferred embodiment of the dissector device 10 of the present invention is shown in FIG. 1. The dissector 10 includes a shaft 11 having a handle 12 attached to the proximal end and a dissecting tip 13 attached to the distal end. As shown in the

15 drawings, the shaft may be either solid or hollow, depending on the application. The tip may be either integral with or detachably connected to the shaft. The shaft and tip may comprise any material having suitable strength, resiliency and biocompatibility, and suitable materials are well known in the art.

20 The handle is configured to permit the required control and manipulation of the device in use. While the handle may vary with the intended use of the device, an advantageous design is shown in FIG. 1 in which the handle includes a grip portion 14 and a push pad 15. Typical use of the device 10 may involve a one-handed procedure with the hand grasping the grip portion 14. Alternatively, the push pad 15 enables a

25 second hand to be used for greater control or to apply an increased force to move the device forward.

-12-

The shaft 11 is shown with a slight upward bend as the shaft extends forward from the handle. This bend is provided for use in the procedure of harvesting the saphenous vein, since it provides clearance for the handle from the patient's foot or ankle during extension of the device from the lower extremity of the leg. For this application, the shaft preferably includes a bend of up to about 45°, more preferably from about 10° to about 30°. Alternatively, the shaft may be straight, arcuate or otherwise shaped, including multiple bends or curves, to suit a particular use.

A dissecting tip 13 is attached to the distal end of the shaft and is configured to facilitate movement of the tip and associated shaft through the body tissue adjacent the vessel. In general, the tip 13 includes a shallow body 16. The size of the dissecting tip, particularly the length, width and thickness, is preferably adapted to the intended use of the device. In a preferred embodiment, the tip is generally concave in shape, facing upwardly in relation to the handle.

The leading, distal edge 17 of the tip is preferably contoured to enhance the ability of the tip to retain the vessel in position and to dissect the vessel from the adjoining body tissue as the device is moved forward. The leading edge may include blunt or sharp portions, or both, and typically has a tapered shape, although other designs are useful in the broadest application of the invention.

In one aspect, a light source is mounted to the device adjacent the dissecting tip. As described hereafter, the light source is provided in association with the dissecting tip in a manner which provides for transillumination of the subject vessel. The term light source is used herein to generally designate a wide variety of devices for providing light, and may include such different types of light sources as actual light-generating devices or fiber optic light sources. The light may be in any suitable spectrum, including visible and infrared (IR).

-13-

In the embodiment shown in FIG. 2, the light source comprises a light 18 positioned above and displaced proximally of the distal edge of the tip. In this embodiment, the tip has a concave body 19 and a reflective upper surface 20. More particularly, the body and reflective surface are contoured to optimize the reflection of light from the light 18 in a lateral, upward direction, thereby transilluminating the vessel through the person's skin. For example, the concave reflecting surface may be such as to define a focal point and the light may then be positioned at about the focal point to cause reflected light to pass substantially parallel and laterally, i.e., transverse of the axis of the shaft and tip.

10 Alternate embodiments are also useful for providing light in the present invention. In FIG. 3 there is shown an embodiment in which a light source 21 is located at the distal end of the dissecting tip. Similarly, the distal tip may include one or more light sources positioned at various locations along the upper surface in a regular or irregular array selected to provide the desired transillumination effect. The embodiment of FIG. 4 provides still another lighting approach in which the body 19' is itself the light source. This may be accomplished, for example, by the use of fiber optic material and suitable selection and treatment of the dissecting tip body, and particularly the upper surface of the body or the edge surrounding the upper surface.

It is a feature of the present invention that the light source is selected to provide an amount of light sufficient to transilluminate the vessel to be visible through the skin. Thus, the type, color, intensity and other parameters of the light are selected to provide the required degree of illumination. Similarly, it is advantageous, though not essential, that the light be configured and directed to optimize its utility in transillumination. For example, in a preferred embodiment the light emanating from the light source is primarily directed laterally, i.e., perpendicular to the skin surface. A light source which directs at least about 50%, more preferably at least about 80%, of the light in a lateral

-14-

direction has the advantage of providing greater efficiency in the use of the light energy, and will also reduce undesirable scattering of the light and reduced visualization of the vessel.

The light sources are embodied in the dissection device in accordance with known techniques. A lighting device may be coupled through wires (not shown) extending within a conduit 22 in the lumen 23 of (FIG. 2) shaft 11, the wires connecting to an internal power source, such as batteries (not shown) located in the handle, or an external power source. Similarly, optical fibers, such as 24 (FIG. 3), may extend along and/or through the tip and shaft to a suitable light source in the handle or external of the device.

Utilizing the foregoing device including lighting means, a method for transilluminating a vessel or the like is readily accomplished. Referring in particular to FIG. 5, the procedure begins with making a short incision 25 adjacent the vessel 26. The proximal part of the vessel may be transected and withdrawn from the leg, as shown in FIG. 5, or simply, and frequently preferably, left intact and simply located for placement of the device. The device 10 is inserted through the incision and the distal tip 13 and light source 18 are positioned posterior of the vessel. The tip and light source are configured to direct light transversely in the direction of the vessel, which is thereby illuminated to be viewed exterior of the patient through the skin.

The device 10 is then moved forwardly into the patient along the posterior side of the vessel with the assistance of the transillumination of the vessel as a guide. The movement of the device is useful in itself in allowing the doctor to visualize the vessel as to its position and structure. In addition, the device is useful for separating the vessel from the surrounding tissue, and ultimately to enable ready removal of the vessel from the patient, if desired.

The present invention also contemplates the use of tubing inserted into the lumen of the vessel. In one aspect, the intraluminal tubing is opaque to aid in visualizing the

-15-

vessel. Alternatively, the intraluminal tubing is provided with a light source which can be used in conjunction with the light provided by the dissecting tip to facilitate visualization of the vessel and/or positioning of the dissecting tip relative to the vessel. For example, the light from the interluminal tubing may be aligned with or centered
5 within the light of the dissecting tip, or aligned between a plurality of lights of the tip, to assure desired positioning. The lights can be provided to be the same or different in color, intensity, etc. to provide contrast between the dissecting tip and the interluminal tubing, further enhancing the manipulation of one relative the other.

Referring in particular to FIG. 6, there is shown an example of the use of
10 interluminal tubing and transillumination in accordance with the present invention. Opaque tubing 27 is shown received with vessel 26. An illuminating tip 13 includes a pair of optical fiber light sources 28 near the distal end. As the tip is passed posterior of the vessel, the opaqueness of the tubing 27 enhances the illumination of the vessel by increasing the contrast of the vessel structure in the light field. In addition, the tubing is
15 shown with a pair of optical fiber light sources 29 and 30. As the tip 13 is moved forward, the opaque tubing and vessel, and particularly the light sources 29 and 30, are maintained in position between the lights 28 to assist in guiding the tip.

Dissection of a vessel or other elongated structure using transillumination is accomplished in the following manner. As described with respect to transillumination,
20 the first step is to make an incision in the body adjacent the target structure, e.g., vessel. A dissecting device is then inserted into the person through the incision, with the dissecting device including a dissecting tip and a light source mounted adjacent to the dissecting tip and directing light laterally. The dissecting tip and light source are then positioned posterior of the vessel with light directed laterally outward in the direction of
25 the vessel. The dissecting device is advanced along the vessel, while visualizing the vessel through the person's skin by means of the light directed by the light source past the

-16-

vessel and through the person's skin. As the device progresses, the vessel is dissected from the surrounding tissue.

The foregoing method is performed with any of the preceding transillumination devices. As described subsequently, this procedure is similarly accomplished with the
5 dissecting devices described hereafter which include retaining structures for retaining the dissecting tip adjacent the vessel as the device is moved along the vessel. With suitable retaining structures, the need for transillumination may be obviated, and the following description therefore contemplates a device and its use with or without transillumination.

The procedures of the present invention may further include additional steps
10 leading to the transection and ultimate harvesting of the vessel. In this regard, in conjunction with advancing the dissection device along the vessel, the vessel is transected at proximal and distal locations to obtain the desired length of vessel for harvesting. The transected vessel dissected from the surrounding tissue is removed from the body. In accordance with such methods, side branches of the vessel are transected, or
15 alternatively ligated and transected, as they are encountered. Cauterization of one or more side branches may also be employed as is understood in the art.

In one preferred application of the device and method, the saphenous vein is harvested from the patient. The procedure is particularly advantageous in that there is reduced trauma to the patient since only short incisions, typically in the range of 2 cm,
20 are required. In some procedures, such as for the saphenous vein, the procedure may employ two or more incisions to allow for reintroduction of the dissection device at different points along the length of the vessel. This allows for the dissection device to be shorter and therefore more manageable, while still being useful to retrieve the full length of the vessel.

25 It also appears that in certain instances, such as for the saphenous vein, any side branches which may be encountered tend not to extend directly inwardly or outwardly

-17-

relative to the skin. Thus, the dissection device can be readily extended into the patient and the side branches are well transilluminated by the light source when used. As is discussed more fully hereafter, the side branches can be separated from the main vessel by means associated with the dissection device, and the vessel thereafter removed.

5 The shaft, as previously noted, may be either solid or hollow in construction. The use of a hollow shaft permits the extension of various devices through the shaft. Such devices would include one or more ligation, suction, irrigation or other devices known in the endoscopic art. The devices may be used, for example, to inject fluids, medicaments, gases or the like into the site. As more particularly described hereafter, clipping and
10 ligating instruments may similarly be introduced in this fashion to complement the operation of the dissecting tip.

 The present invention also provides various unique design features for the dissection device, and particularly the dissecting tip. In particular, the dissecting tip preferably includes one or more structures to retain the tip in position adjacent the
15 selected vessel as the tip is advanced relative to the vessel. These design features enhance the utility of the device in particular methods, including for example the harvesting of the saphenous vein. These features are advantageous both with and without the presence of the lighting source previously described.

 The dissecting tip preferably includes a generally tapered design with a reduced
20 profile at the tip to assist in insertion of the tip into the tissue surrounding the vessel or other structure. One form of retaining structure comprises recesses, projections or other shapes adjacent to the distal end of the tip to facilitate moving the tip along the proper course to track closely with the position of the vessel. As the distal end progresses through the tissue, it is important that it does not divert significantly from the location of
25 the vessel. At the same time, the distal end provides the initial dissection of tissue.

-18-

A second form of retaining structure comprises recesses, projections or other shapes displaced from the distal end of the dissecting tip to complete the dissection of tissue from around the vessel and to transect side branches as necessary. It is a feature of certain of these retaining structures that the vessel can be received within an essentially
5 all-encompassing structure, thereby assisting in maintaining the tip in position along the vessel.

An alternate embodiment of the dissecting tip is shown in FIGs. 7-9, in which the tip includes a trough 127 formed at the distal end of the tip 128. The trough comprises a central area which is displaced downwardly of the adjacent portions of the tip, thereby
10 defining a central platform 129 and a pair of mutually facing side walls 130. The vessel 26 (FIG. 8) is received therein against the platform and between the side walls 130. Similarly, the dissecting tip may include a pair of tabs 132 which extend upwardly at the distal end of the tip for reception of a vessel therebetween. It will be appreciated that these two types of retaining structures are comparable in retaining the distal end of the
15 dissecting device in position relative to the vessel, and may be used separately or together. Further variations of these design features which hold the vein in relative lateral position relative to the distal end of the dissecting tip are equally useful.

A further retaining structure is provided by a pair of arms 33 which extend upwardly from the tip at a location displaced from the distal end of said tip, and which
20 define a confinement space 33a for reception of the vessel. The upstanding arms preferably include at most a relatively small gap 34 between the mutually-facing ends 35 of the arms to enhance the ability of the arms to retain the vessel in the area below the arms. The small gap 34 is sized sufficient to allow the vessel to be received therebetween, but in a relatively close fit to maximize the ability of the arms to retain the
25 vessel in place. One approach is to size the gap as approximately the diameter of the target vessel. However, the gap may actually be sized substantially smaller and still

-19-

operate to receive the vessel therethrough, for example by making the gap about the size of the vessel when it is collapsed, e.g., about two wall thicknesses.

In alternate designs, the arms 33 have other configurations. Shown in FIGS. 10-14 is a design in which the arms slightly overlap laterally, one over the other, and are spaced
5 apart from one another a distance sufficient to receive a vessel therebetween. For example, the device 36 includes one arm 37 which is positioned above and overlaps the second arm 38. A small gap 39 (FIG. 13) remains between the overlapping arms to permit the vessel, tendon or the like to be moved into position between and below the arms. Also shown in this embodiment is a keel 40 extending along the underside of the
10 tip to facilitate control of the device as it is moved forward.

In FIGS. 15-16 is shown an embodiment 41 including a pair of arms 42 which terminate in ends which are mutually-facing and which abut one another. These arms are preferably sufficiently flexible and spring loaded to permit displacement of the ends of the arms away from each other a sufficient distance to permit a vessel or the like to be
15 received therebetween. Alternatively, a closed connection of the arms, or an integral wall, can be used, in which case the vessel is transected and then placed through the space underlying the arms.

These retaining arms of various configuration all serve the purpose of confining the vessel within the dissecting tip as the tip progresses through the surrounding tissue. In
20 general, the retaining arms provide a means for surrounding the vessel at a location displaced from the distal end of the tip. At the same time, means are also provided to enable the vessel to be moved from outside of the enclosure defined by the arms to inside the enclosure. As indicated, such means can be provided by using arms that have a narrow gap therebetween or that abut but are separable.

25 Alternative designs are also contemplated which otherwise provide for placing the vessel within the enclosing arms but protecting against the vessel coming back out from

-20-

inside the arms as the tip is being advanced through the tissue. For example, a spring-biased lever may be incorporated into one of the arms which permits only movement in the inward direction. Such a lever would permit the vessel to be moved into the arms, but would prevent movement in the opposite direction. Such a lever can be readily
5 provided by means of a "living hinge" integrally connecting the lever portion with the rest of the supporting arm.

The device further preferably includes surfaces which facilitate the dissection of the vessel from the surrounding tissue, as well as transection of side branches of the vessel. Referring to FIG. 7, the dissecting tip 28 includes a leading edge 42 which
10 initially engages the tissue surrounding the vessel as the device 10 is moved forward. As desired for a given application, this leading edge may be provided with either a dull or sharp edge for dissecting the vessel from the surrounding tissue. Similarly, the leading edge of the central trough, when included, may also be provided with either a dull or sharp edge to suit the use of the device. The leading edge may optionally include at
15 these locations attached cutting members, such as metal cutting blades, e.g., blades 43 (FIG. 17).

The upstanding tabs 32 have upper edges 44 which may also be either dull or sharp. In one design, the edges 44 are sharp and will have the effect of cutting through the surrounding tissue. Such sharp edges may also impact side branches of the vessel
20 and will have utility in transecting such side branches as they are encountered. Thus, the tabs 32 can be employed for helping to retain the device in position relative to the vessel and/or to transect side branches of the vessel.

In the alternative, the tabs 32 may be provided with dull upper edges. This design maintains the use of the tabs for retaining the device adjacent the vessel, and can also be
25 used in conjunction with subsequent cutting edges on the upstanding arms as hereafter described.

-21-

The upwardly extending arms 33 have particular use in both retaining the device adjacent the vessel and potentially in dissecting the vessel from the surrounding tissue and in transecting side branches. In addition to acting as retainers or guides, the arms in combination with the body of the dissecting tip provide a full or substantially full enclosure 34 around the vessel as the tip is advanced. The front edges 45 of the arms include portions which encounter surrounding tissue not addressed by the preceding portions of the dissecting tip. Therefore, in one aspect the front edges are provided with either dull or sharp edges, as desired, to further dissect the vessel from the adjacent tissue. Selection of dull or sharp edges is determined based on other design aspects of the dissecting tip and/or the intended use of the device.

The upwardly extending arms 33 also have particular utility in transecting side branches of the vessel. In a preferred embodiment, the front edges of the arms define notches 46 into which side branches are received as the device is moved forward. The presence of the upstanding tabs 132 will operate in conjunction with the arms by moving the side branches into position for reception within the notches. Thus, the tabs may be provided with either sharp or dull upper edges which will cooperate with the following arms, and particularly the notches 46, to transect side branches. For example, dull upper edges of the upstanding tabs will be useful in directing side branches upwardly into position against the front edges of the arms 33, and particularly into notches 46 when provided.

The dissecting tip may include cutting blades or equivalent structures at any of the positions indicated to be useful for dissecting the tissue or transecting side branches. In addition to cutting blades 43 at the leading edge of the trough 27, such blades or equivalent cutting structures are suitably incorporated at a variety of other locations including the lead and upper edges of the tabs 132, the front edges of the arms 33, and/or the notches 46.

-22-

In a further alternate design, the gap between the arms can be configured in various other ways to enhance the use of the dissecting tip. As shown in FIGs. 18-21, for example, the arms can be designed to provide an S-shaped gap which further resists accidental removal of the vessel from between the arms. A further feature of this design is that it positions the exiting of the vessel in the proximal direction at a location adjacent the bottom of the tip, rather than near the top. This can be preferable in certain applications of the device in terms of aligning and progressing the tip through the tissue.

Referring in particular to FIGS 18-21, there is shown a dissecting tip 47 having an S-shaped gap 48. As in the previous embodiments, the body of the tip defines a central opening 49 in which the vessel is received. In particular, the vessel is received over the distal end 50 of the tip and the rounded forward end, and thereafter extends through the central opening and exits downwardly through the opening 51. In this embodiment, the S-shaped gap 48 is defined by a first portion 52 and a second portion 53. The second portion 53 includes a hooked end 54 which further serves to entrap the vessel within the gap and prevent its escape during manipulation of the device.

The dissecting tip may also be equipped for cauterization as the tip is extended through the tissue and transects the side branches of the vessel. The design and use of cauterizing implementation is well known in the art, and the present invention may employ the range of such devices. RF electricity has been used for decades to cauterize and coagulate tissue in surgical procedures. Devices used to apply RF energy to tissue fall generally into two categories: monopolar and bipolar. Bipolar electrosurgical instruments incorporate both active and return electrodes into the surgical instrument, substantially restricting the flow of electric current to tissue that is placed between the electrodes. In monopolar electrosurgical instruments, on the other hand, the return electrode is placed outside the patient's body, on the patient's skin. Thus, in a monopolar electrosurgical instrument, current flows from the active or treatment

-23-

electrode through the patient's body to the return electrode. Both monopolar and bipolar electrosurgical instruments rely at least in part on resistance heating to cauterize and/or cut tissue.

The cauterization feature may be employed at a variety of locations of the
5 dissecting tip in accordance with the design requirements for such devices. For example, as shown diagrammatically in FIG. 22, the upstanding arms 55 may comprise monopolar wires, with the arms transecting and cauterizing the side branches as the tip is moved forward. Alternatively, the embodiment of FIG. 23 includes arms 56 comprising a pair
10 of parallel segments 57 and 58 which incorporate bipolar wires separated by an insulating layer 157 and are used to cauterize the side branches as they are cut. A dissecting tip with a continuous arch 59, as opposed to separate arms, is shown in FIG. 24, in which the arch includes a monopolar wire used for cauterization. The full range of
cautery designs, such as bipolar and monopolar RF electrodes and other energy sources, may be readily incorporated as a part of the dissecting tip of the present invention.

15 Referring to a further particular design for a cautery instrumentation, there is shown in FIGS 18-20 a design including two pairs of bipolar cautery elements 64 and 65. The cautery elements are positioned within the slots 66 and 67 on opposed sides of the dissecting tip. 47. Wires 68 and 69 extend through the lower tip portion 70 to
interconnect the elements in slot 66 with the elements in slot 67. Further, wires 71 and
20 72 connect with the cautery elements 64, 65 in slot 67 and extend through the dissecting tip body 73 and interior of shaft 74 to connect the cautery elements with an external power source (not shown). Tissue or side branches received within the slots 66 and 67 are cauterized by the application of power to the cautery elements 64 and 65 in
accordance with the known operation of such cautery devices. In addition, while various
25 designs of the cautery elements may be employed, an example of a particular cautery design useful with the present invention is disclosed in pending application Serial No.

-24-

_____, entitled RF Bipolar Mesentery Takedown Device Including C-Shaped Electrodes, filed by Scott D. Wampler et al. on February 2, 1999, and hereby incorporated by reference.

As a further feature of the present invention, the shaft 11 may include one or more lumens extending the length thereof. Alternative designs are shown in FIGS. 25 and 26. The dissecting device 60 of FIG. 25 includes a single lumen 61 having an arcuate shape. Clip applicators and various other devices 62 may be extended through the lumen 61 and positioned as desired for use adjacent to the dissecting tip. In the alternative design of FIG. 26, the shaft is provided with a plurality of lumens 63 extending the length of the shaft which allow one or more devices 62 to be extended therethrough to selected locations relative to the dissecting tip.

For any of the foregoing devices, the various light sources and retaining features may be included in the full range of possible combinations, as desired for the intended use of the device. For example, the dissecting tip may include only the distal trough and upwardly extending arms, with or without a light source. Alternatively, the dissecting tip may include only the upstanding tabs, or the tabs in combination with the upwardly extending arms. The full range of combinations of design elements are contemplated as a part of the present invention.

The components of the described devices and attendant features may be provided in a similar wide range of specific designs and materials. The dissecting tip and shaft are formed of suitable biocompatible material of types well known in the art. The dissecting tip may be configured to be permanently affixed to the shaft, or may be separable from the shaft such as by a threaded coupling. In use, the entire device or only certain parts, typically the dissecting tip and shaft, may be disposable.

The foregoing devices are useful in performing visualization, dissection and/or harvesting of vessels of the body. Embodiments which do not include lighting means are

-25-

equally useful and advantageous for purposes of dissecting, and potentially harvesting, vessels. Although not limited in this respect, preferred methods of the present invention will be further described in respect to the exemplary use with respect to the saphenous vein. The following description is directed to a dissecting device with lighting means,
5 but it will be appreciated that such method is directly suitable for use without transillumination in moving the device relative to the selected vessel.

A minimally-invasive surgical procedure is exemplified in the FIGS. 27-30. In accordance with a typical procedure, a vessel is dissected from surrounding tissue within the body of the person. An incision 25 is made in the body adjacent the vessel 26 and a
10 dissecting device 10 is inserted into the person through the incision. The dissecting device includes a shallow, concave dissecting tip 13 having retaining structures for assisting in retaining the dissecting tip in position with respect to the vessel as the tip is advanced relative to the vessel.

The dissecting tip 13 is positioned with the vessel 26 received by the retaining
15 structures of the tip and the tip is then advanced along the vessel. In this process, the retaining structures operate to retain the dissecting tip in position relative to the vessel to cause dissection of the vessel from the surrounding tissue.

As the dissecting tip 13 is advanced, the associated retaining structures and dissecting surfaces will act in the manner previously described. For example, as the tip is
20 moved forward the vessel 26 is received within and retained by the provided retaining structures, which may include any or all of a trough 127 in the distal end of the tip, upwardly extending tabs 132 at the distal end of the tip, and arms 33 extending upwardly from the tip at a position displaced from the distal end of the tip.

Also, the confronting edges or surfaces of these various design features of the tip
25 will contact the surrounding tissue and/or side branches. As the device is pushed forward through the body, as depicted successively in FIGS. 27-30, side branches ride up over

-26-

and/or are transected by the front tabs. The front edges of the arms, including notches when provided, will transect any side branches and dissect the vessel from any adjoining tissue which is engaged by such edges.

If the vessel is to be harvested, then additionally the vessel is transected at selected
5 proximal and distal locations and the separated vessel is removed. Transection of the vessel will typically be accomplished through incisions made in the body adjacent the desired proximal and distal locations of the vessel.

While the invention has been illustrated and described in detail in the drawings and foregoing description, the same is to be considered as illustrative and not restrictive in
10 character, it being understood that only the preferred embodiment has been shown and described and that all changes and modifications that come within the spirit of the invention are desired to be protected.

-27-

WHAT IS CLAIMED IS:

1. A device useful for minimally-invasive surgical procedures involving a vessel of the body, said device comprising:
 - a shaft having a proximal end and a distal end;
 - 5 a handle attached to the proximal end of said shaft;
 - a tip attached to the distal end of said shaft; and
 - a light source mounted adjacent said tip and directing light laterally of said tip.
2. The device of claim 1 in which said light source is mounted to said tip.
3. The device of claim 2 in which said light source is mounted to the distal
10 end of said tip.
4. The device of claim 1 in which said light source comprises said tip including a body which radiates light outwardly therefrom.
5. The device of claim 1 in which said tip has a reflecting surface and said light source is positioned adjacent the reflecting surface of said tip to reflect light
15 therefrom.
6. The device of claim 1 in which said tip includes a plurality of lights.
7. The device of claim 1 in which said tip includes retaining structures for assisting in retaining said tip in position adjacent the vessel.
8. The device of claim 7 in which said retaining structures includes a trough
20 formed in the distal end of said tip for reception of the vessel therein.
9. The device of claim 7 in which said retaining structures includes a pair of tabs extending upwardly at the distal end of said tip for reception of the vessel therebetween.
10. The device of claim 7 in which said retaining structures includes a pair of
25 arms extending upwardly from said tip at a location displaced from the distal end of said tip, the pair of arms defining a confinement space for reception of the vessel therein.

-28-

11. The device of claim 10 in which said retaining structures includes a trough formed in the distal end of said tip for reception of the vessel therein.

12. The device of claim 10 in which said retaining structures further includes a pair of tabs extending upwardly at the distal end of said tip for reception of the vessel
5 therebetween.

13. The device of claim 1 in which said shaft defines a lumen extending longitudinally therethrough.

14. A dissection device useful for minimally-invasive surgical procedures involving a vessel of the body, said device comprising:
10 a shaft having a proximal end and a distal end;
a handle attached to the proximal end of said shaft; and
a shallow, concave tip attached to the distal end of said shaft, said tip including retaining structures for retaining the vessel adjacent said tip as said tip is moved along the vessel.

15. The dissecting device of claim 14 in which said shaft includes a bend.

16. The dissecting device of claim 14 in which said shaft includes a central lumen extending therethrough.

17. The dissecting device of claim 14 in which said tip includes a keel on the underside to assist in directing the tip as it is moved along the vessel.

20 18. The dissecting device of claim 14 in which said tip includes cautery means for cauterizing tissue adjacent the tip.

19. The device of claim 14 in which the retaining structures include a trough formed in the distal end of said tip for reception of a vessel therein.

25 20. The device of claim 19 in which said tip includes a sharp front edge of the trough.

-29-

21. The device of claim 14 in which the retaining structures include a pair of tabs extending upwardly at the distal end of said tip for reception of a vessel therebetween.

22. The device of claim 21 in which the tabs include sharp upper edges.

5 23. The device of claim 21 and which further includes a trough formed in the distal end of said tip for reception of a vessel therein.

24. The device of claim 14 in which the retaining structures include a pair of arms extending upwardly from said tip at a location displaced from the distal end of said tip, the pair of arms defining a confinement space for reception of a vessel therein.

10 25. The device of claim 24 in which said arms extend up and abut with one another to define a closed space in which the vessel is received.

26. The device of claim 24 in which the arms include sharp front edges.

27. The dissecting device of claim 25 in which said shaft includes a central lumen extending therethrough.

15 28. The dissecting device of claim 25 in which said tip includes cautery means for cauterizing tissue adjacent the tip.

29. The device of claim 25 in which the arms include front edges which define sharp notches within which side branches of a vessel are receivable.

20 30. The device of claim 25 in which the arms extend upwardly and toward each other, the arms terminating in ends which are mutually-facing and are spaced apart from one another a distance sufficient to receive a vessel therebetween.

31. The device of claim 25 in which the arms extend upwardly and toward each other, the arms terminating in ends which are overlapping one over the other and are spaced apart from one another a distance sufficient to receive a vessel therebetween.

-30-

32. The device of claim 25 in which the arms extend upwardly and toward each other, the arms terminating in ends which are mutually-facing and which abut one another.

33. The device of claim 32 in which the arms are sufficiently flexible to permit
5 displacement of the ends away from each other a sufficient distance to permit a vessel to be received therebetween.

34. The device of claim 25 in which said arms define an S-shaped slot therebetween.

35. The device of claim 25 in which the retaining structures further include a
10 trough formed in the distal end of said tip for reception of a vessel therein.

36. The device of claim 25 in which the retaining structures further include a pair of tabs extending upwardly at the distal end of said tip for reception of a vessel therein.

37. The device of claim 36 in which the retaining structures include a trough
15 formed in the distal end of said tip for reception of a vessel therein.

38. A dissection tip useful for minimally-invasive surgical procedures involving a vessel of the body, said tip comprising:
a shallow concave body including retaining structures for assisting in retaining said tip in position adjacent a vessel as said tip is advanced along the vessel.

39. The tip of claim 38 in which the retaining structures include a trough
20 formed in the distal end of said tip for reception of a vessel therein.

40. The tip of claim 39 in which the trough includes a sharp front edge.

41. The tip of claim 38 in which the retaining structures include a pair of tabs extending upwardly from said tip at the distal end of said tip for reception of a vessel
25 therebetween.

42. The tip of claim 41 in which the tabs include sharp upper edges.

43. The tip of claim 41 and which further includes a trough formed in the distal end of said tip for reception of a vessel therein.

44. The device of claim 38 in which the retaining structures include a pair of arms extending upwardly from said tip at a location displaced from the distal end of said tip, the pair of arms defining a confinement space for reception of a vessel therein.

45. The device of claim 44 in which the arms include sharp front edges.

46. The device of claim 44 in which the arms include front edges which define notches within which side branches of a vessel are receivable.

47. The device of claim 44 in which the arms extend upwardly and toward each other, the arms terminating in ends which are mutually-facing and are spaced apart from one another a distance sufficient to receive a vessel therebetween.

48. The device of claim 44 in which the arms extend upwardly and toward each other, the arms terminating in ends which are overlapping one over the other and are spaced apart from one another a distance sufficient to receive a vessel therebetween.

49. The device of claim 44 in which the arms extend upwardly and toward each other, the arms terminating in ends which are mutually-facing and which abut one another.

50. The device of claim 44 in which the arms are sufficiently flexible and spring loaded to permit displacement of the ends away from each other a sufficient distance to permit a vessel to be received therebetween.

51. The device of claim 44 in which the retaining structures further include a trough formed in the distal end of said tip for reception of a vessel therein.

52. The device of claim 44 in which the retaining structures further include a pair of tabs extending upwardly from said tip at the distal end of said tip for reception of a vessel therebetween.

-32-

53. The device of claim 44 in which the retaining structures further include a trough formed in the distal end of said tip for reception of a vessel therein.

54. A method for visualizing a vessel of the body through the person's skin, which method comprises:

5 making an incision in the body adjacent the vessel;

inserting a transillumination device through the incision, the transillumination device comprising a shaft having a distal end and a light source carried at the distal end of the shaft and directing light laterally;

10 positioning the transillumination device with the light source posterior of the vessel and with light directed laterally outward in the direction of the vessel; and

advancing the transillumination device along the vessel to enable visualization of the vessel through the person's skin.

55. The method of claim 54 in which the vessel is a vein.

56. The method of claim 55 in which the vein is the saphenous vein.

15 57. A method for dissecting a vessel from surrounding tissue within the body of a person using visualization of the vessel through the person's skin, which method comprises:

making an incision in the body adjacent the vessel;

20 inserting a dissecting device into the person through the incision, the dissecting device including a dissecting tip and a light source mounted adjacent the dissecting tip and directing light laterally;

positioning the dissecting tip and light source posterior of the vessel with light directed laterally outward in the direction of the vessel;

25 visualizing the vessel through the person's skin by means of the light source directing light past the vessel and through the person's skin; and

advancing the dissecting device along the vessel by means of said visualizing of the vessel, the dissecting tip operating in said advancing to dissect the vessel from surrounding tissue.

5 58. The method of claim 57 in which the light source comprises a light source mounted to the dissecting tip.

59. The method of claim 58 in which the light source is mounted to the distal end of the dissecting tip.

60. The method of claim 57 in which the light source comprises the dissecting tip including a body which radiates light transversely outward therefrom.

10 61. The method of claim 57 in which the dissecting tip has a reflecting surface and the light source is positioned adjacent the reflecting surface of said dissecting tip to reflect therefrom.

62. The method of claim 57 in which the dissecting tip includes retaining structures for retaining a vessel in position adjacent said tip, said method further
15 comprising positioning the vessel within the retaining structures carried by the dissecting device for assisting in retaining the dissecting tip adjacent the vessel.

63. The method of claim 62 and which includes positioning the vessel within a trough formed in the distal end of the dissecting tip.

64. The method of claim 62 and which includes positioning the vessel between
20 a pair of tabs extending upwardly from the dissecting tip at the distal end of the dissecting tip.

65. The method of claim 62 and which includes positioning the vessel within a confinement area defined between a pair of arms extending upwardly from the dissecting tip at a location displaced from the distal end of the dissecting tip.

66. The device of claim 65 in which the arms extend upwardly and toward each other, the arms terminating in ends which are mutually-facing and are spaced apart from one another a distance sufficient to receive a vessel therebetween.

67. The device of claim 66 in which said arms define an S-shaped slot
5 therebetween.

68. The device of claim 65 in which the arms extend upwardly and toward each other, the arms terminating in ends which are overlapping one over the other and are spaced apart from one another a distance sufficient to receive a vessel therebetween.

69. The device of claim 65 in which the arms extend upwardly and toward each
10 other, the arms terminating in ends which are mutually-facing and which abut one another.

70. The device of claim 65 in which the arms are sufficiently flexible to permit displacement of the ends away from each other a sufficient distance to permit a vessel to be received therebetween.

71. The method of claim 65 and which includes positioning the vessel within a
15 trough formed in the distal end of the dissecting tip.

72. The method of claim 65 and which includes positioning the vessel between a pair of tabs extending upwardly from the dissecting tip at the distal end of the dissecting tip.

73. The method of claim 57 in which the vessel is a vein.
20

74. The method of claim 73 in which the vein is the saphenous vein.

75. A method for harvesting a vessel from within the body of a person using visualization of the vessel through the person's skin, which comprises:

making an incision in the body adjacent the vessel;

-35-

inserting a dissecting device into the person through the incision, the dissecting device including a dissecting tip and a light source mounted adjacent the dissecting tip and directing light laterally;

5 positioning the dissecting tip and light source posterior of the vessel with light directed outwardly in the direction of the vessel;

visualizing the vessel through the person's skin by means of the light source directing light past the vein and through the person's skin;

10 advancing the dissecting device along the vessel by means of said visualizing of the vessel, the dissecting tip operating in said advancing to dissect the vessel from surrounding tissue;

transecting the vessel at proximal and distal locations; and

removing the vessel from the body.

76. The method of claim 75 and which further includes transecting at least one side branch of the vessel.

15 77. The method of claim 75 and which further includes ligating and transecting at least one side branch of the vessel.

78. The method of claim 75 and which further includes cauterizing at least one side branch of the vessel or resistant connective tissue.

20 79. The method of claim 75 in which the dissecting tip has a reflecting surface and the light source is positioned adjacent the reflecting surface of said dissecting tip to reflect therefrom.

80. The method of claim 75 and which further comprises positioning the vessel within retaining structures carried by the dissecting device for assisting in retaining the dissecting tip along the vessel.

25 81. The method of claim 75 in which the vessel is a vein.

82. The method of claim 81 in which the vein is the saphenous vein.

-36-

83. A method for dissecting a vessel from surrounding tissue within the body of a person which comprises:

making an incision in the body adjacent the vessel;

5 inserting a dissecting device into the person through the incision, the dissecting device including a shallow, concave dissecting tip having retaining structures for assisting in retaining the dissecting tip in position with respect to the vessel as the tip is advanced relative to the vessel;

positioning the dissecting tip with the vessel received by the retaining structures of said tip; and

10 advancing the dissecting tip along the vessel, the retaining structures of the dissecting tip operating in said advancing to retain the dissecting tip in position relative to the vessel to cause dissection of the vessel from surrounding tissue.

84. The method of claim 83 which includes positioning the vessel within a trough formed in the distal end of the dissecting tip.

15 85. The method of claim 83 which includes positioning the vessel between a pair of tabs extending upwardly at the distal end of the dissecting tip.

86. The method of claim 83 which includes positioning the vessel within a confinement area defined between a pair of arms extending upwardly from the dissecting tip at a location displaced from the distal end of the dissecting tip.

20 87. The method of claim 86 which further includes positioning the vessel within a trough formed in the distal end of the dissecting tip.

88. The method of claim 86 which further includes positioning the vessel between a pair of tabs extending upwardly at the distal end of the dissecting tip.

89. The method of claim 83 in which the vessel is a vein.

25 90. The method of claim 89 in which the vein is the saphenous vein.

-37-

91. A method for harvesting a vessel from within the body of a person which comprises:

making an incision in the body adjacent the vessel;

5 inserting a dissecting device into the person through the incision, the dissecting device including a shallow, concave dissecting tip having retaining structures for assisting in retaining the dissecting tip in position with respect to the vessel as the tip is advanced relative to the vessel;

positioning the dissecting tip with the vessel received by the retaining structures of said tip;

10 advancing the dissecting tip along the vessel, the retaining structures of the dissecting tip operating in said advancing to retain the dissecting tip in position relative to the vessel to cause dissection of the vessel from surrounding tissue;

transecting the vessel at proximal and distal locations; and

removing the vessel from the body.

15 92. The method of claim 91 and which further includes transecting at least one side branch of the vessel.

93. The method of claim 91 and which further includes ligating and transecting at least one side branch of the vessel.

20 94. The method of claim 91 and which further includes cauterizing at least one side branch of the vessel.

95. The method of claim 91 in which the vessel is a vein.

96. The method of claim 95 in which the vein is the saphenous vein.

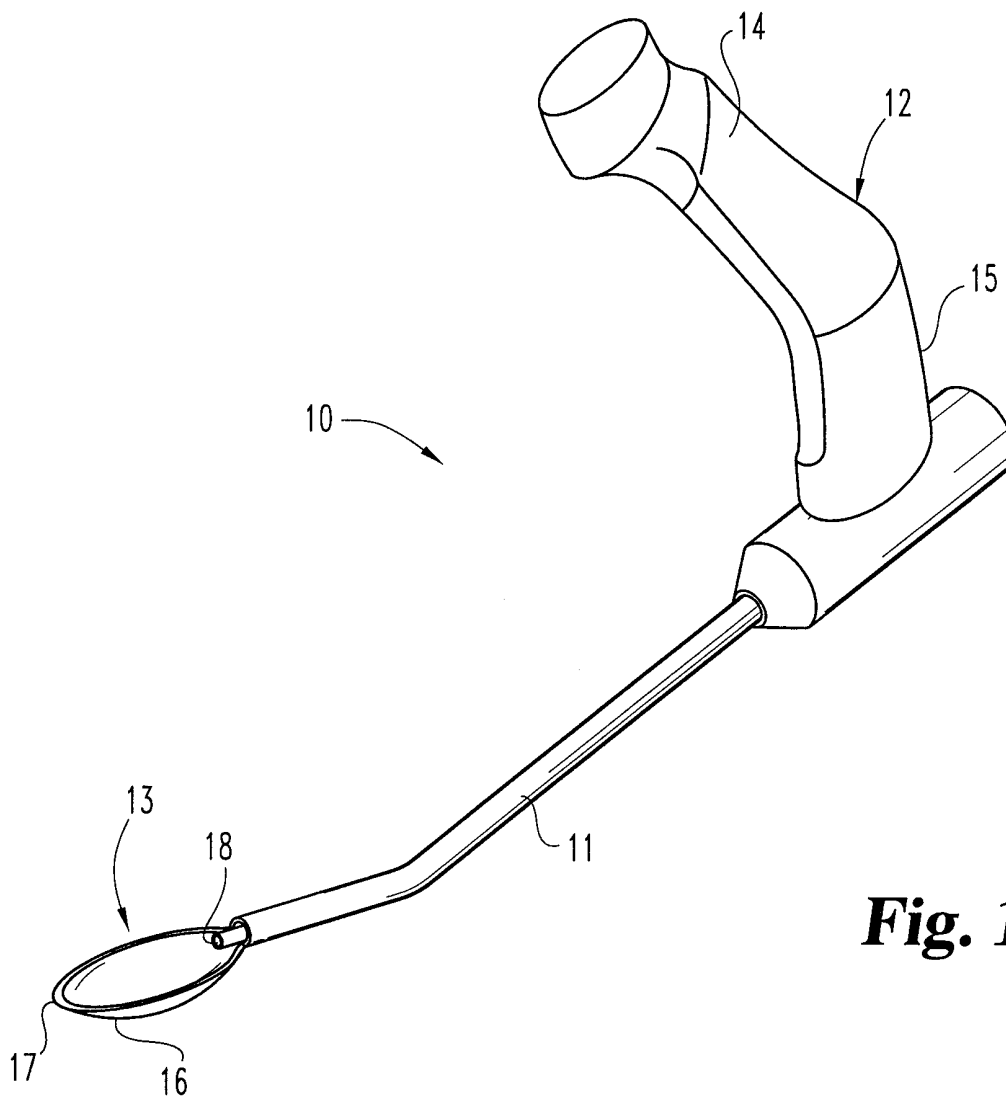

Fig. 1

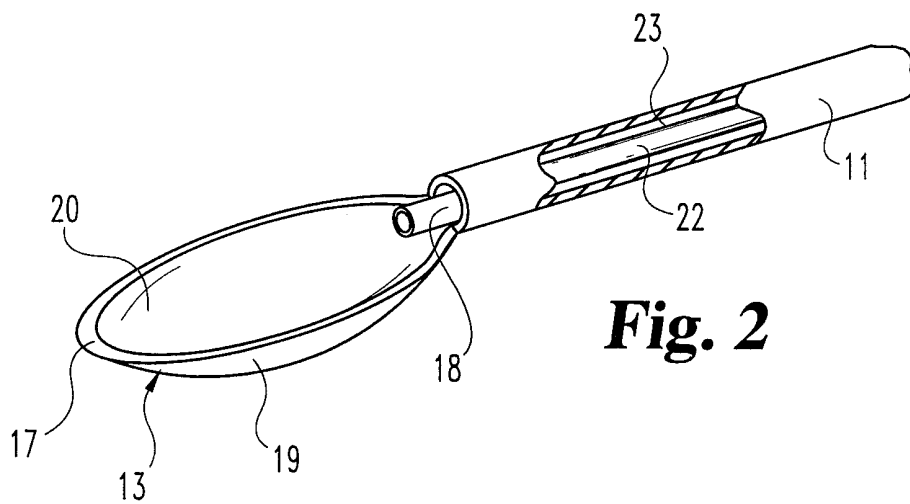
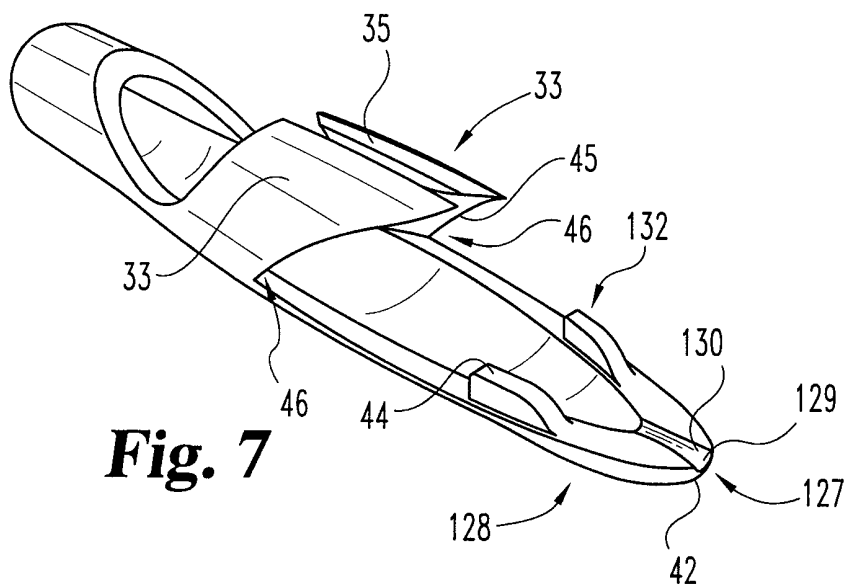
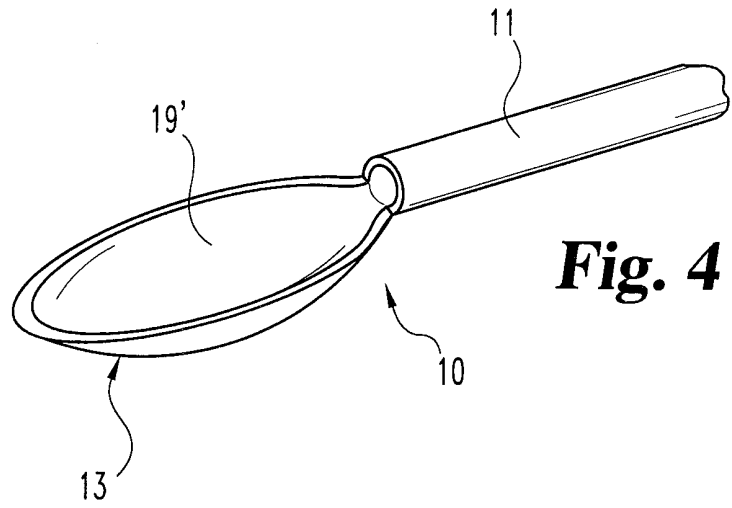
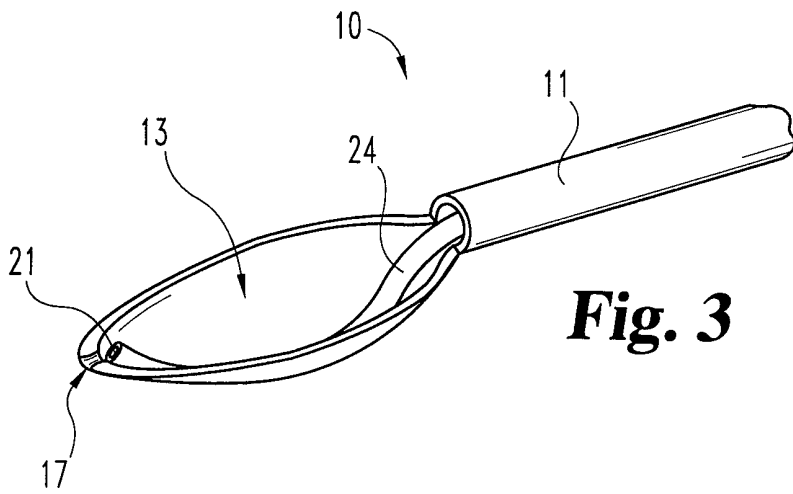

Fig. 2



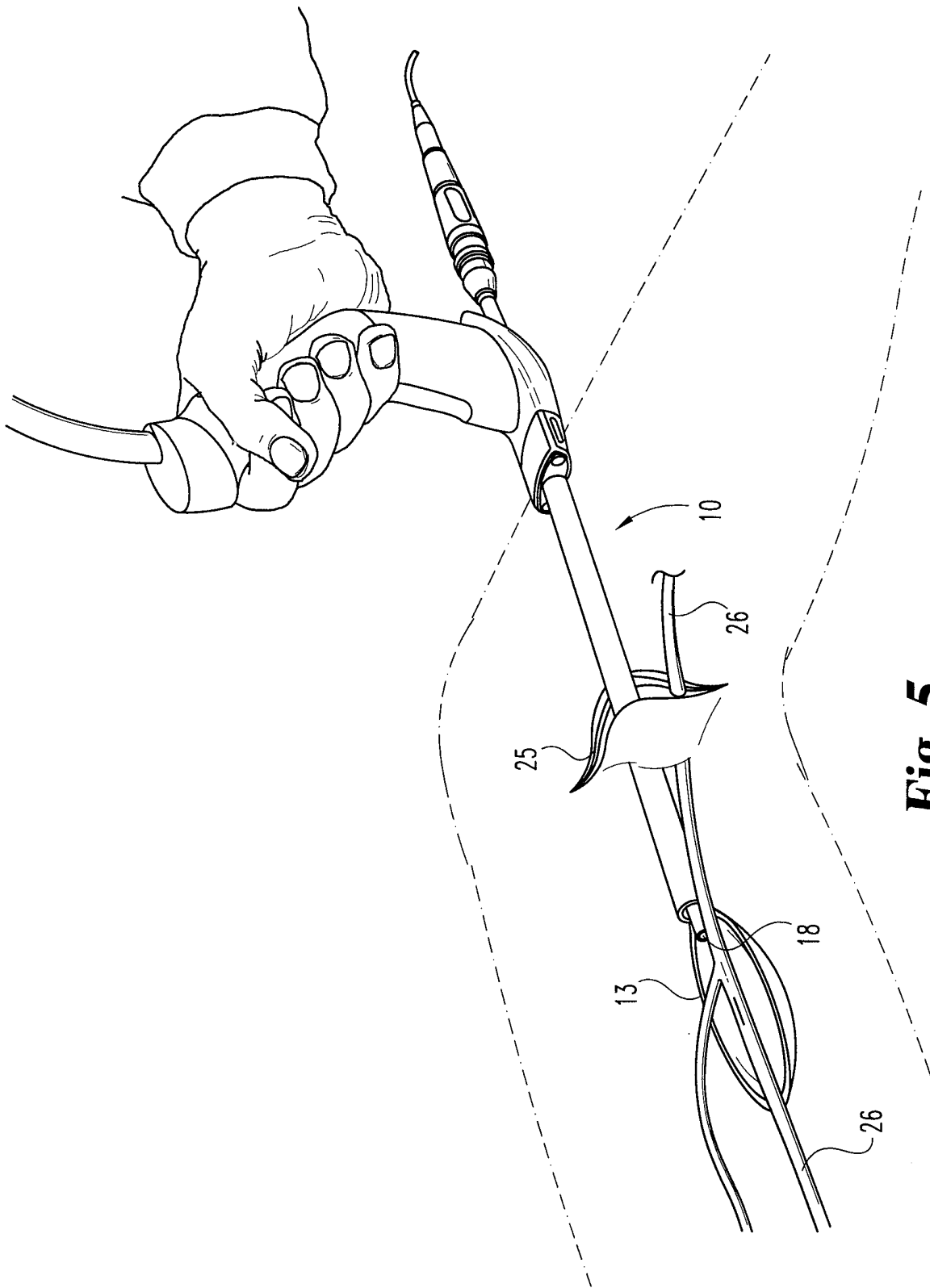

Fig. 5

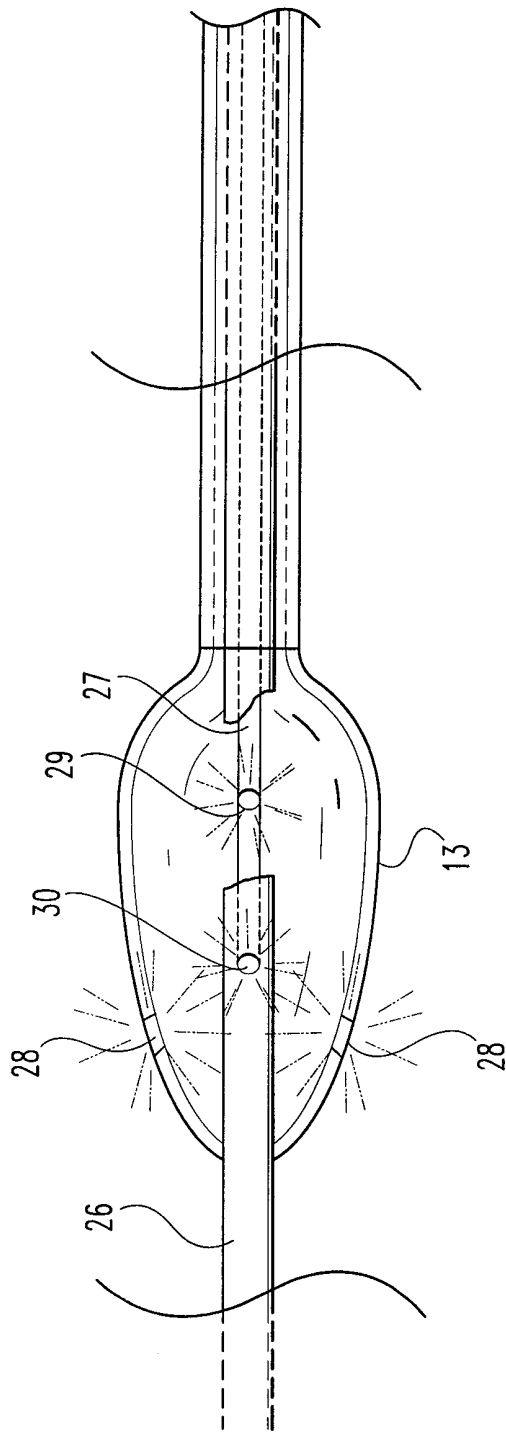

Fig. 6

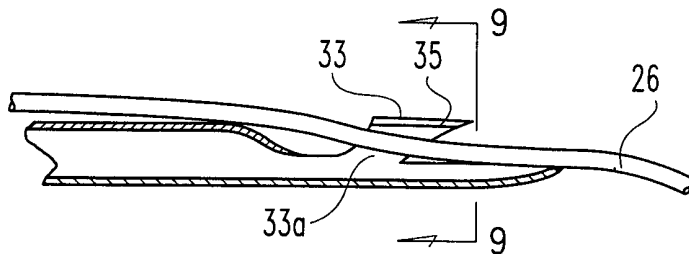

Fig. 8

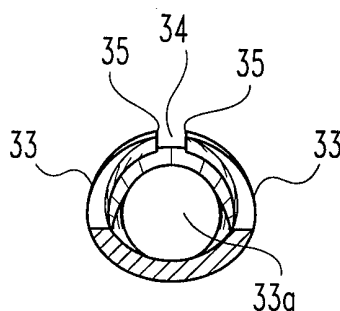

Fig. 9

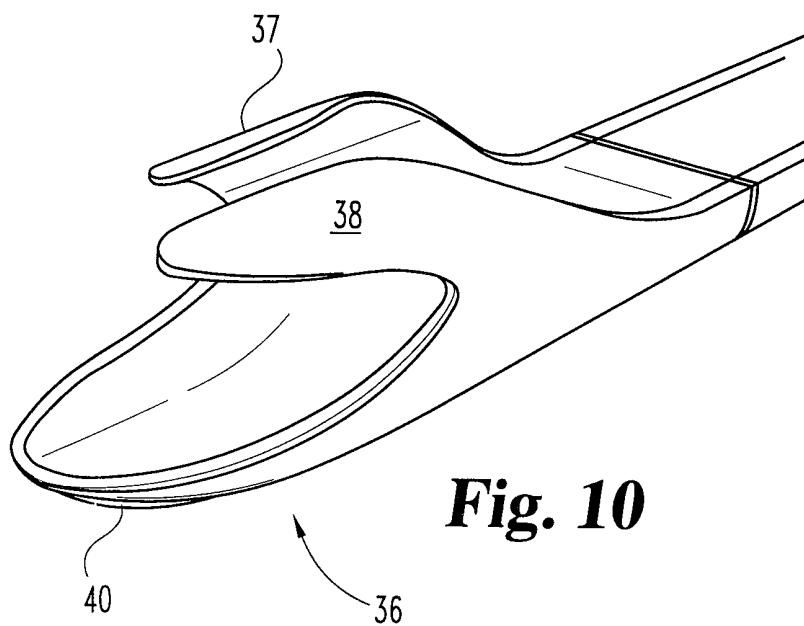

Fig. 10

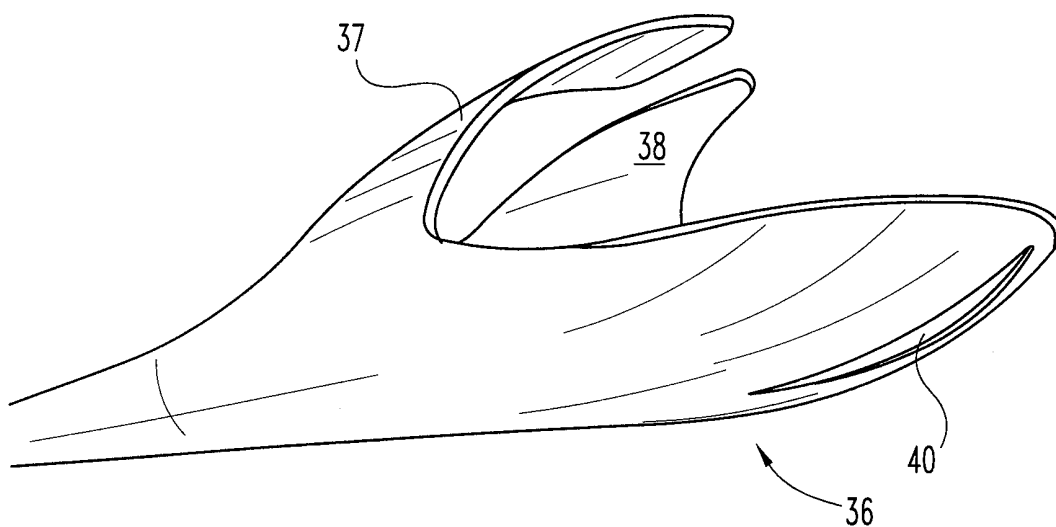

Fig. 11

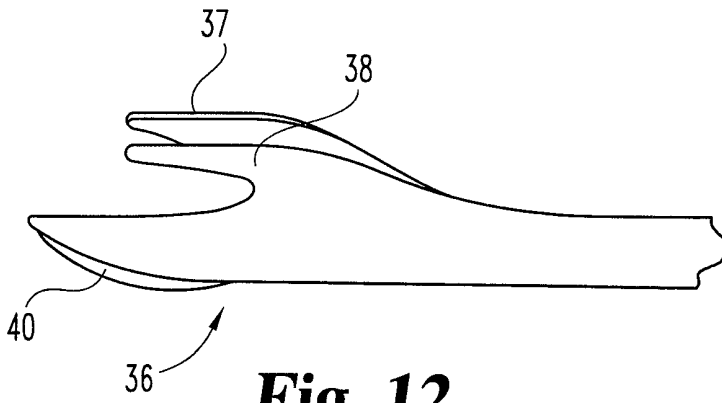

Fig. 12

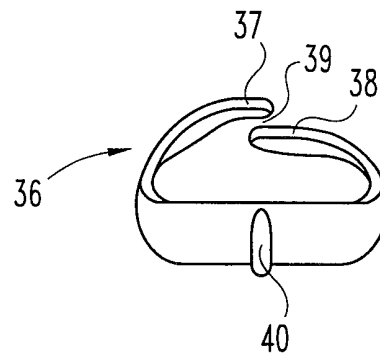

Fig. 13

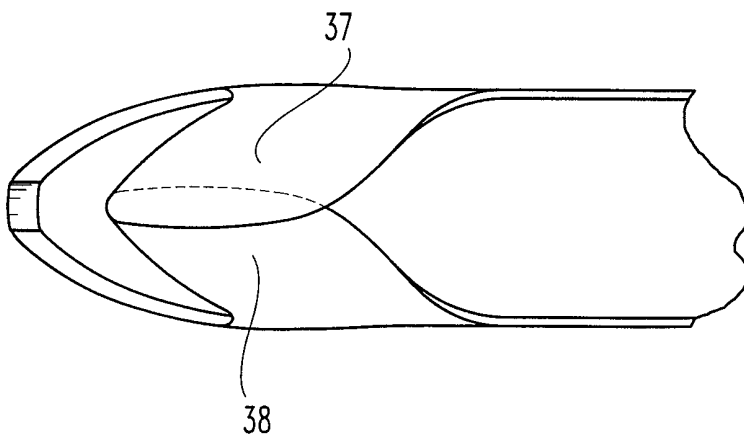

Fig. 14

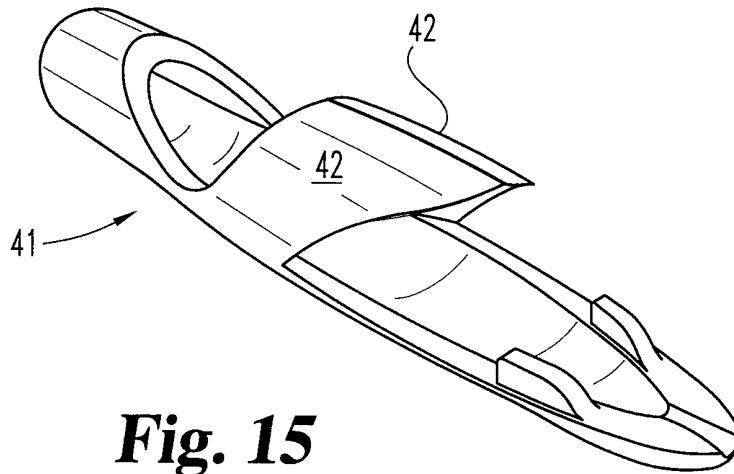

Fig. 15

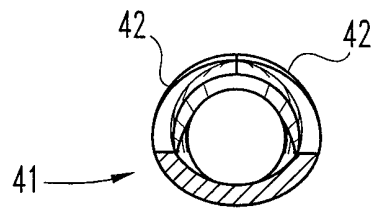

Fig. 16

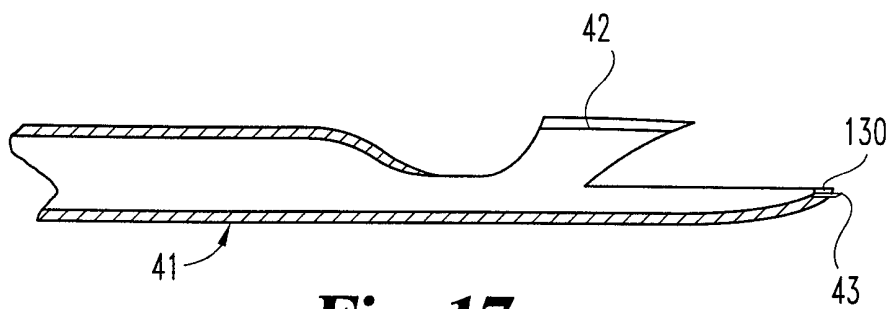

Fig. 17

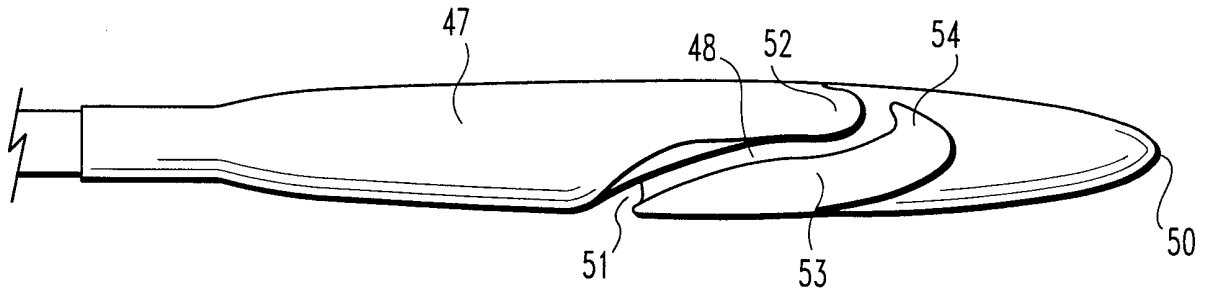

Fig. 18

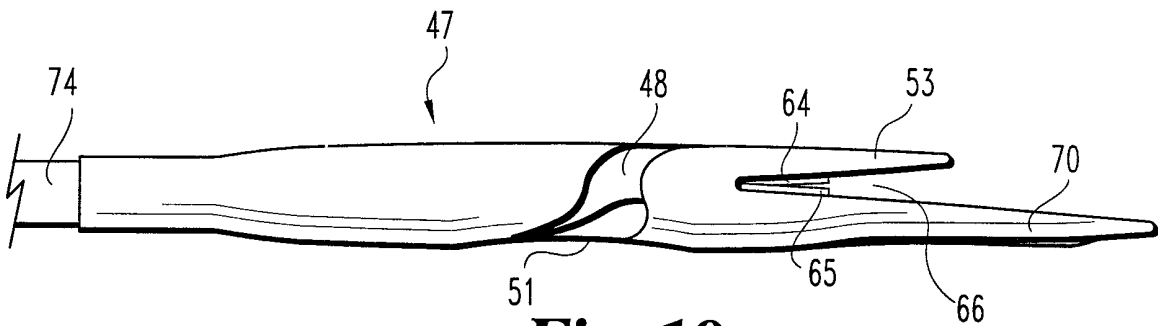

Fig. 19

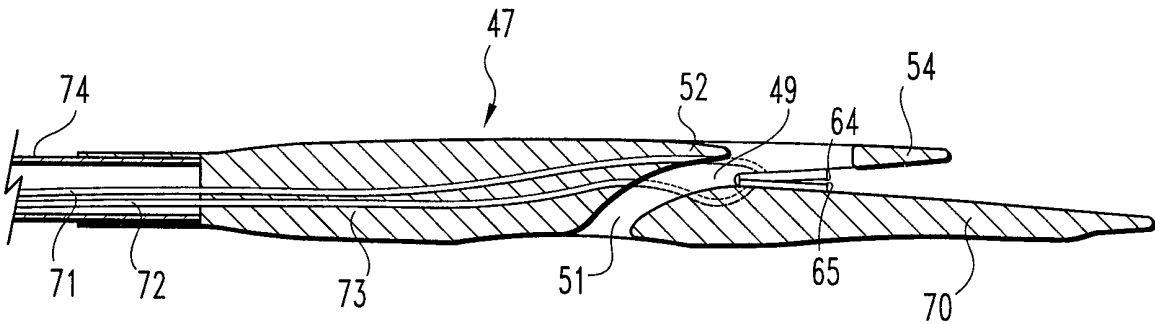

Fig. 20

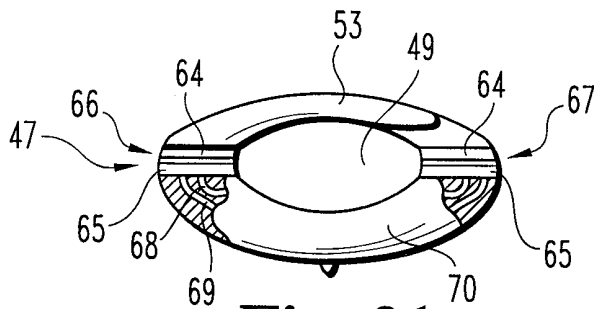

Fig. 21

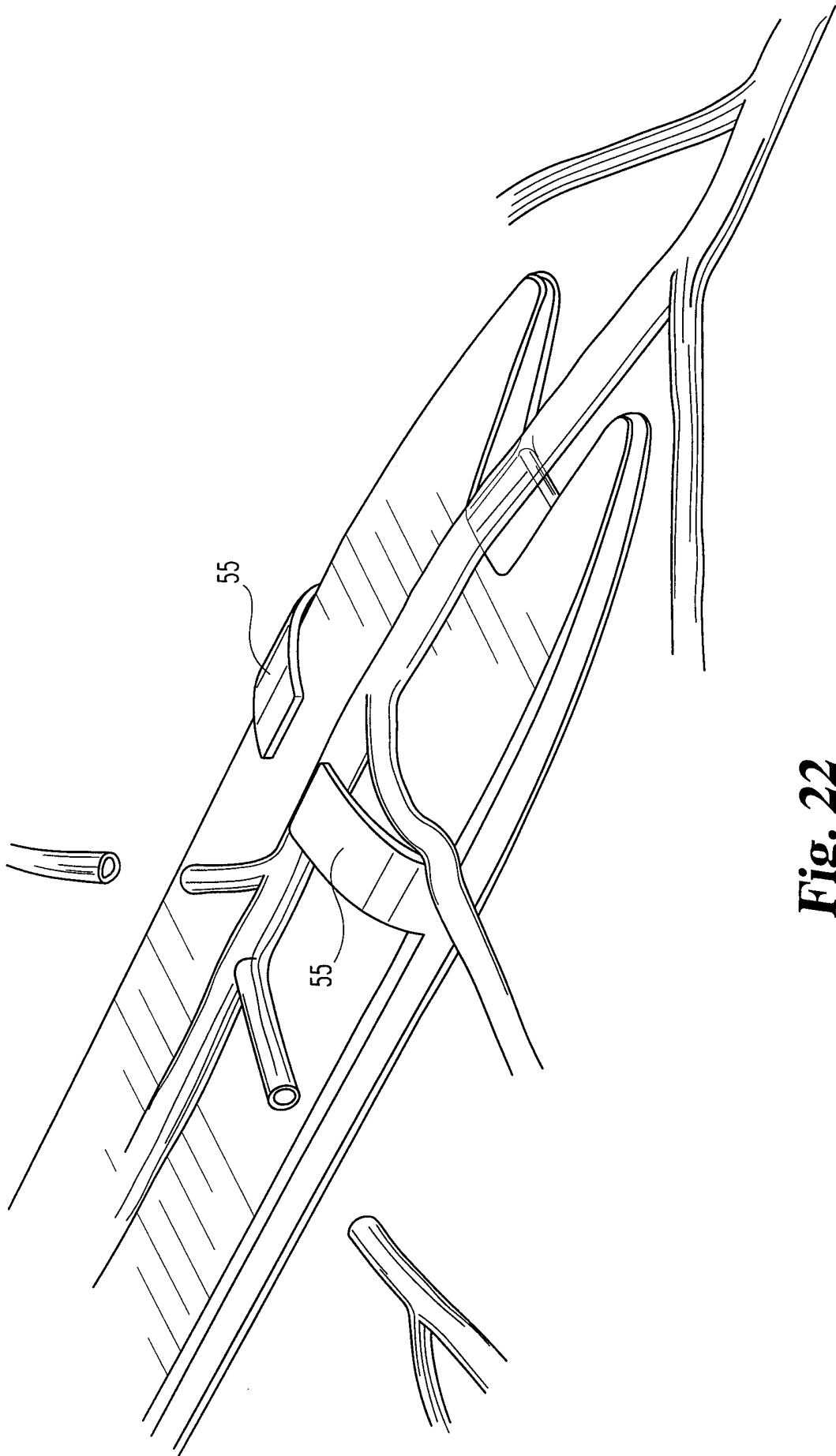

Fig. 22

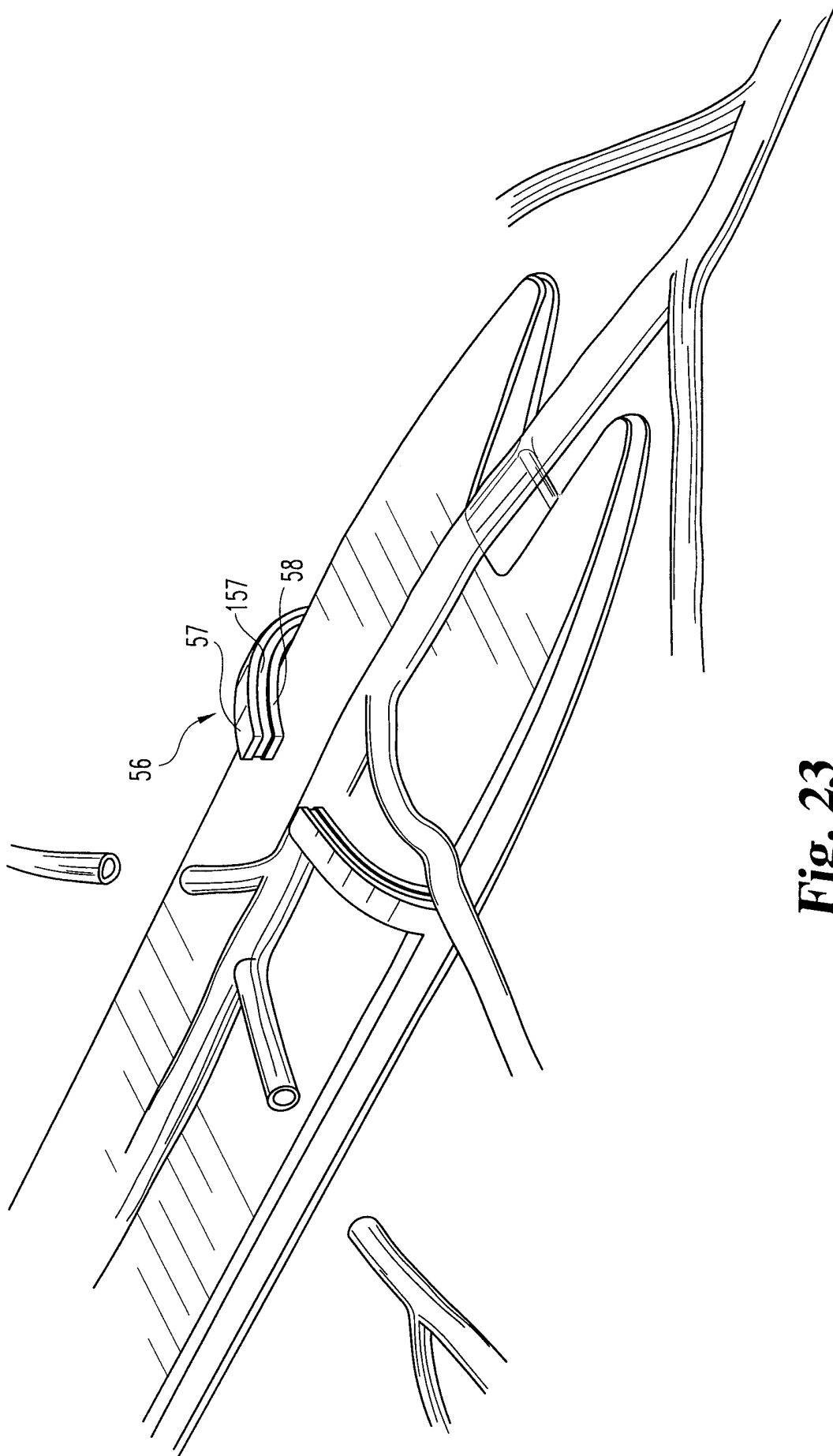

Fig. 23

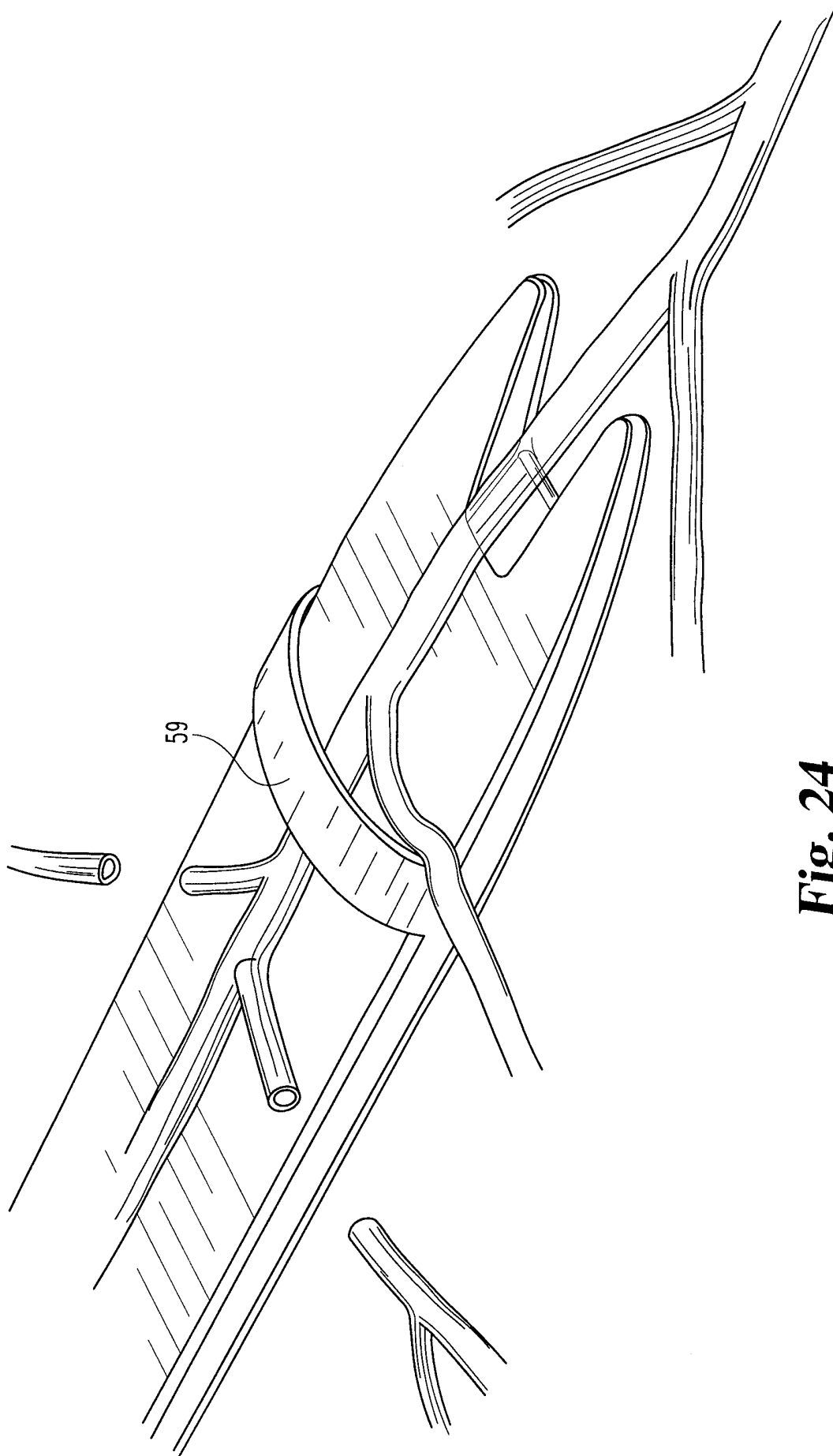

Fig. 24

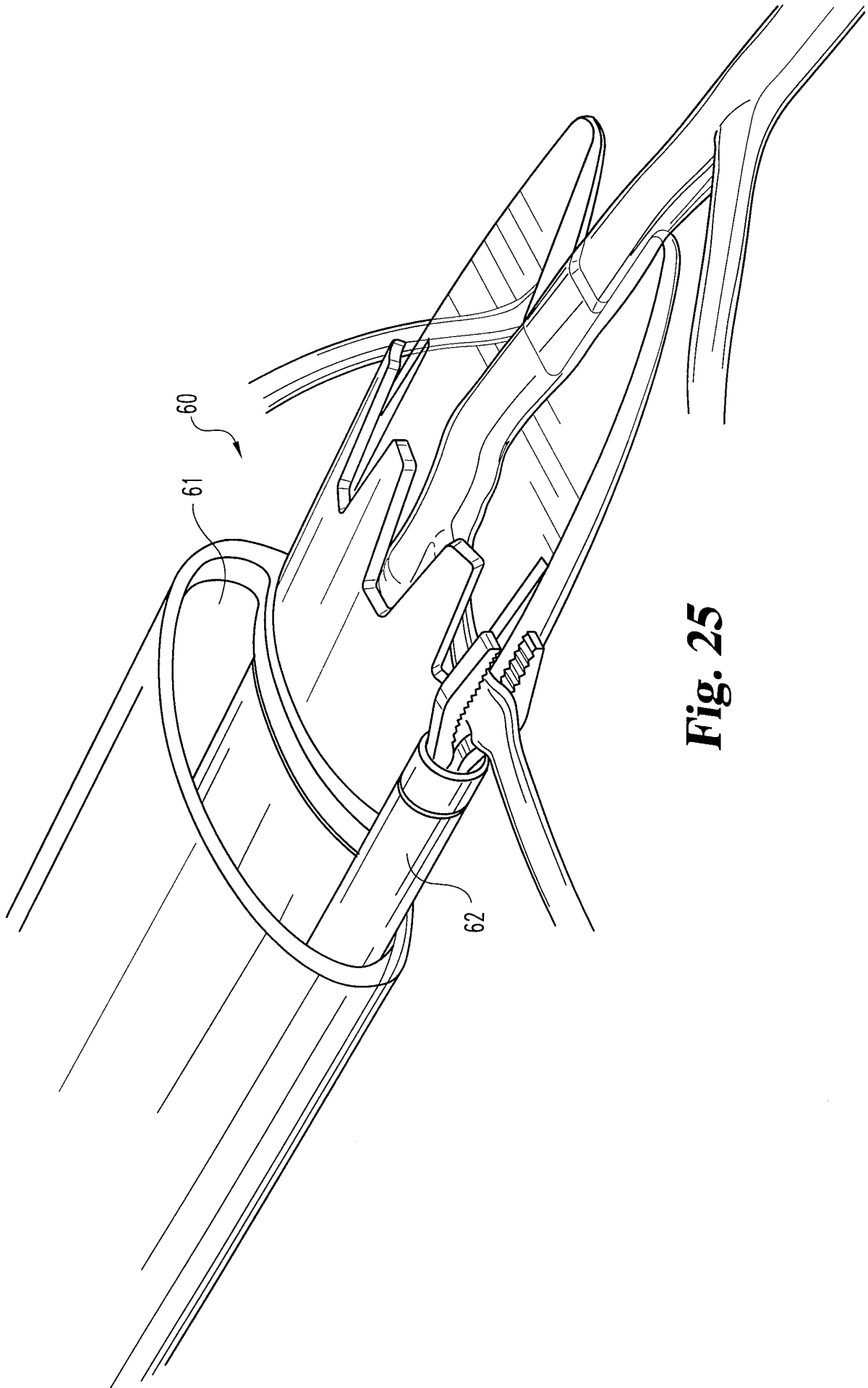

Fig. 25

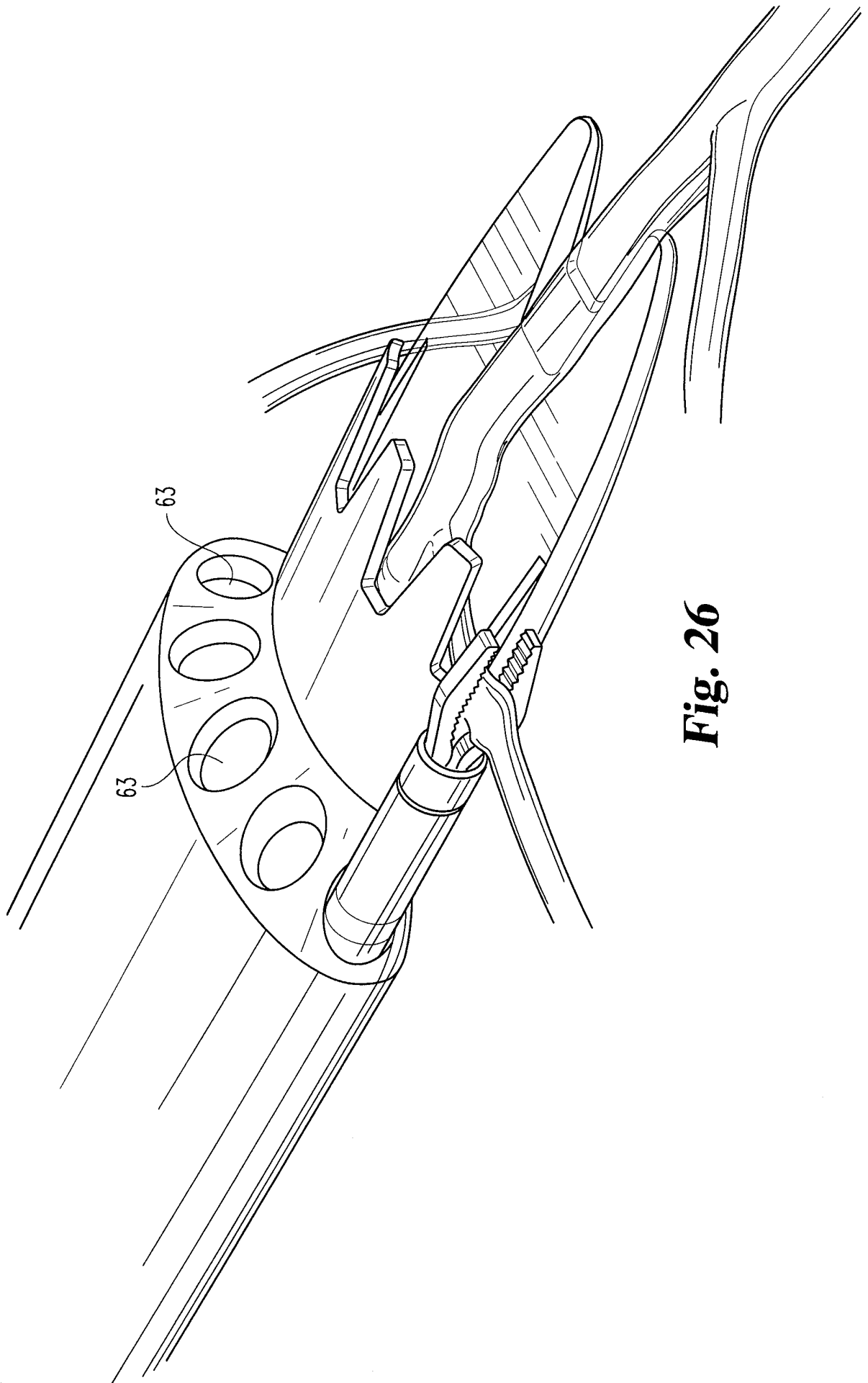

Fig. 26

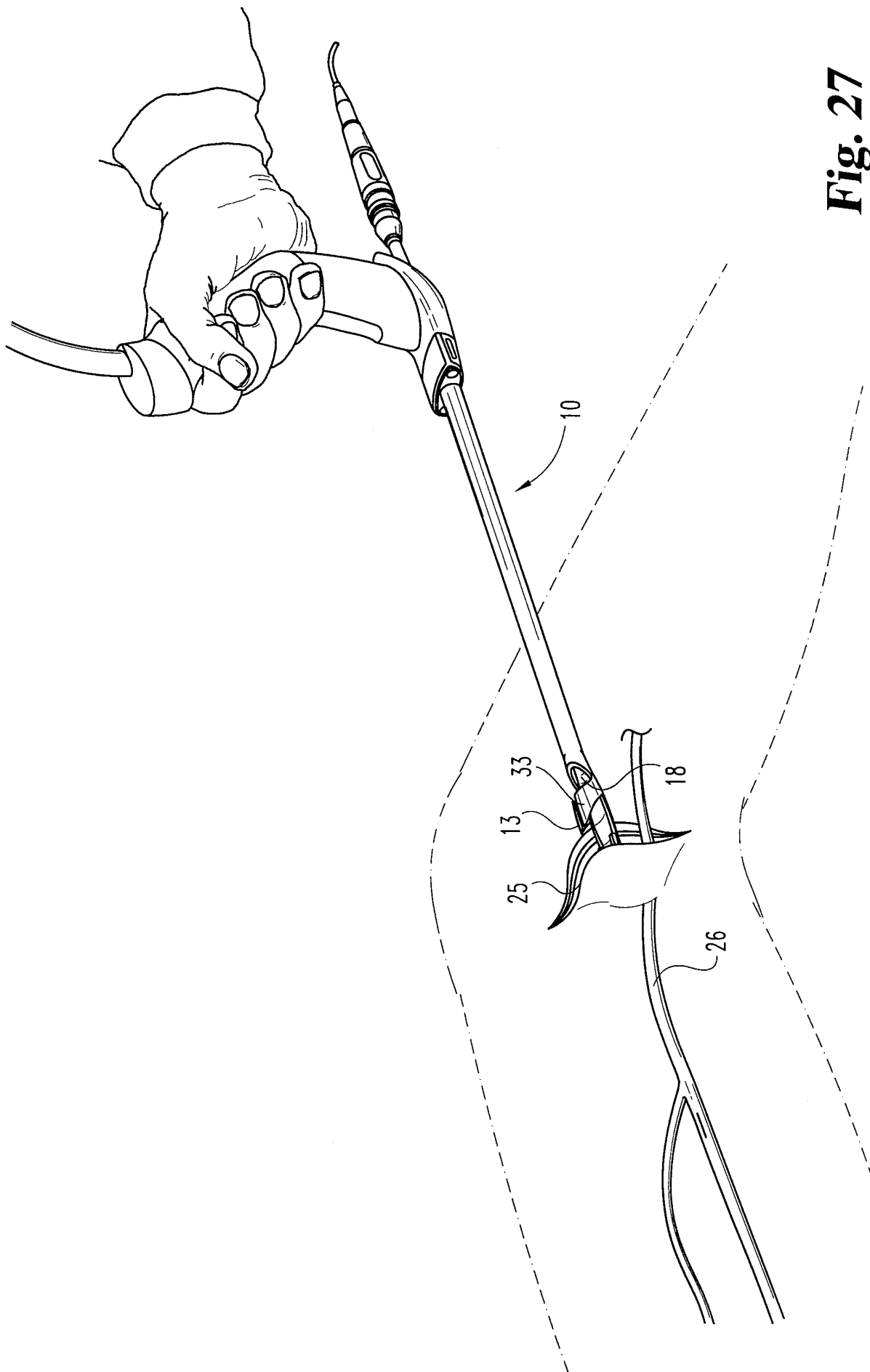

Fig. 27

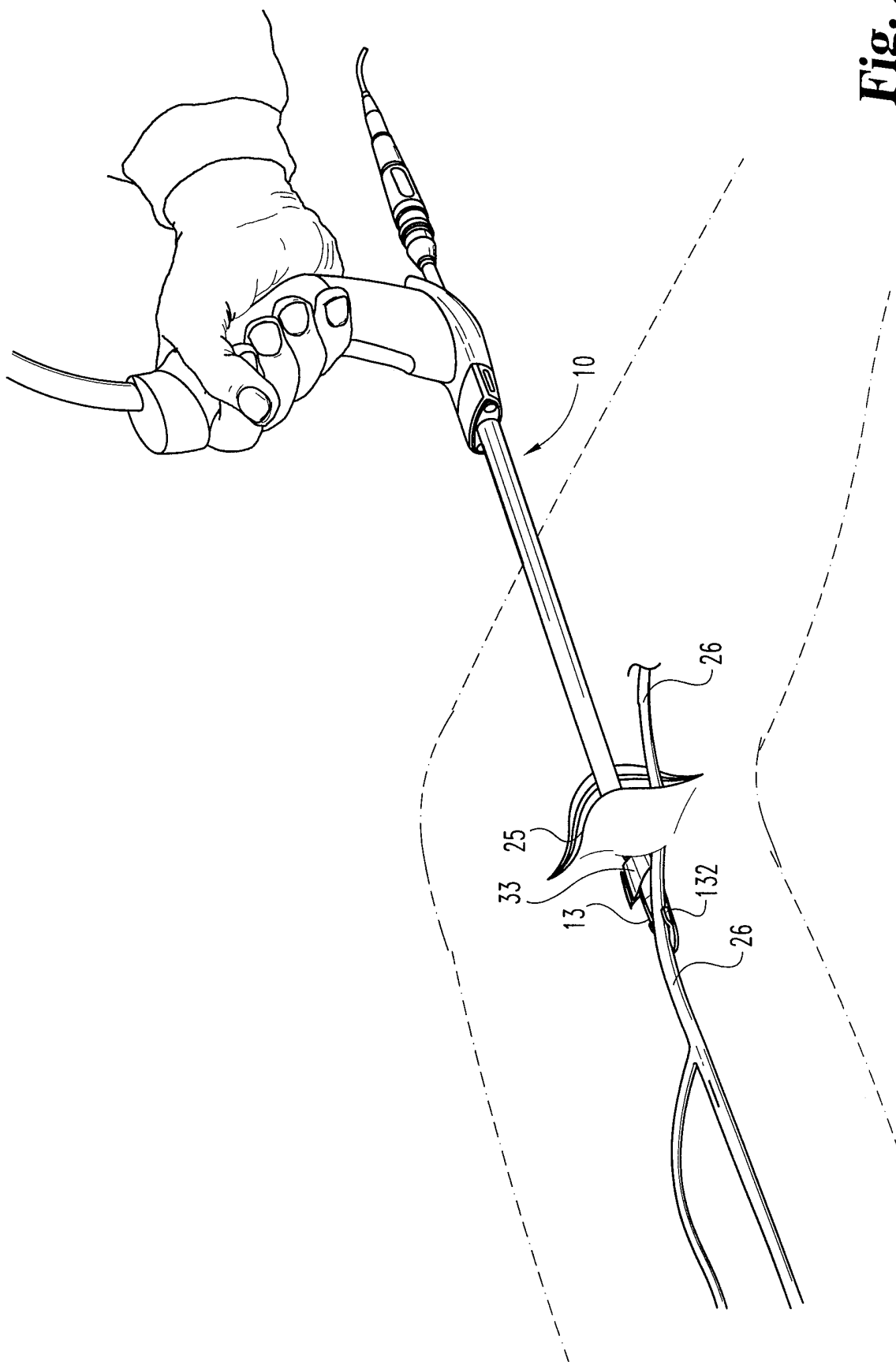

Fig. 28

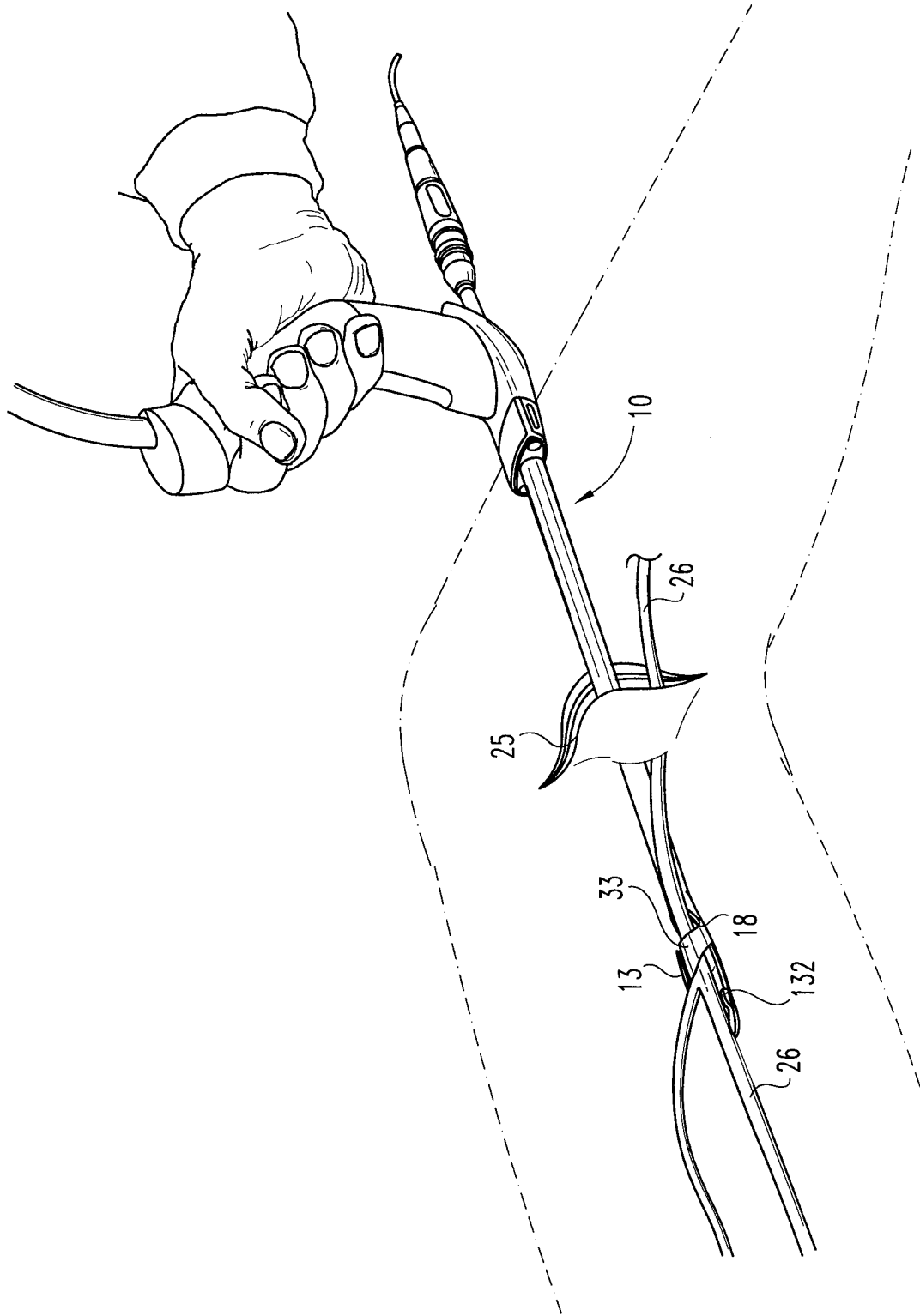

Fig. 29

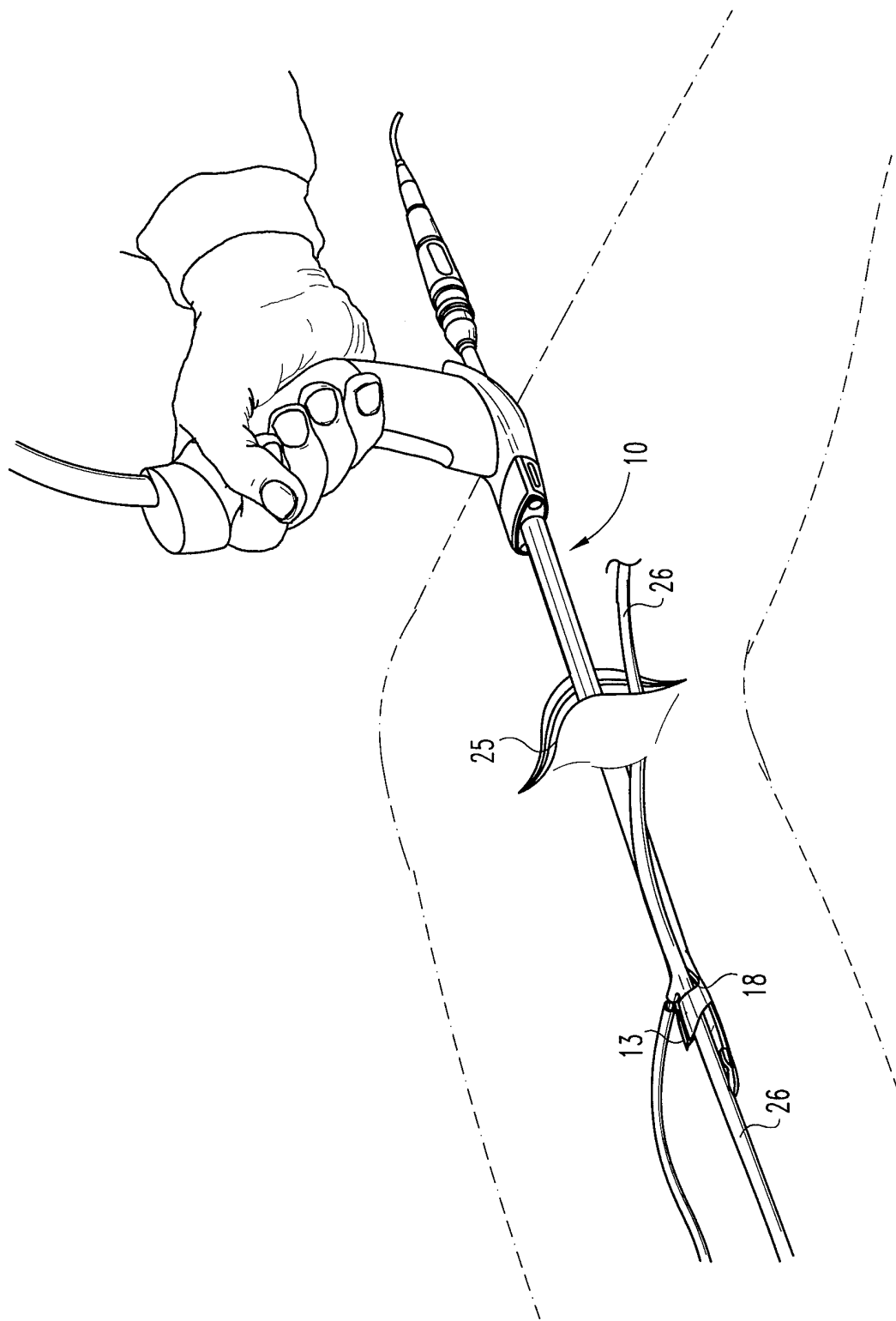

Fig. 30

INTERNATIONAL SEARCH REPORT

International application No.
PCT/US99/02594

A. CLASSIFICATION OF SUBJECT MATTER
 IPC(6) :A61B 5/00
 US CL :606/001
 According to International Patent Classification (IPC) or to both national classification and IPC

B. FIELDS SEARCHED
 Minimum documentation searched (classification system followed by classification symbols)
 U.S. : 600/160, 178, 179, 182, 183, 245; 606/001; 607/88-92

Documentation searched other than minimum documentation to the extent that such documents are included in the fields searched
 NONE

Electronic data base consulted during the international search (name of data base and, where practicable, search terms used)
 NONE

C. DOCUMENTS CONSIDERED TO BE RELEVANT

Category*	Citation of document, with indication, where appropriate, of the relevant passages	Relevant to claim No.
X	US 5,667,480 A (KNIGHT et al) 16 September 1997, whole document.	1-13
X	US 5,373,840 A (KNIGHTON) 20 December 1994, whole document.	1-13

Further documents are listed in the continuation of Box C. See patent family annex.

* Special categories of cited documents:	"T" later document published after the international filing date or priority date and not in conflict with the application but cited to understand the principle or theory underlying the invention
"A" document defining the general state of the art which is not considered to be of particular relevance	"N" document of particular relevance; the claimed invention cannot be considered novel or cannot be considered to involve an inventive step when the document is taken alone
"E" earlier document published on or after the international filing date	"Y" document of particular relevance; the claimed invention cannot be considered to involve an inventive step when the document is combined with one or more other such documents, such combination being obvious to a person skilled in the art
"L" document which may throw doubts on priority claim(s) or which is cited to establish the publication date of another citation or other special reason (as specified)	"&" document member of the same patent family
"O" document referring to an oral disclosure, use, exhibition or other means	
"P" document published prior to the international filing date but later than the priority date claimed	

Date of the actual completion of the international search: 12 JULY 1999
 Date of mailing of the international search report: 22 JUL 1999

Name and mailing address of the ISA/US: Commissioner of Patents and Trademarks, Box PCT, Washington, D.C. 20231, Facsimile No. (703) 305-3230
 Authorized officer: MICHAEL PEFFLEY, Telephone No. (703) 308-4305

INTERNATIONAL SEARCH REPORT

International application No.
PCT/US99/02594**Box I Observations where certain claims were found unsearchable (Continuation of item 1 of first sheet)**

This international report has not been established in respect of certain claims under Article 17(2)(a) for the following reasons:

1. Claims Nos.:
because they relate to subject matter not required to be searched by this Authority, namely:

2. Claims Nos.:
because they relate to parts of the international application that do not comply with the prescribed requirements to such an extent that no meaningful international search can be carried out, specifically:

3. Claims Nos.:
because they are dependent claims and are not drafted in accordance with the second and third sentences of Rule 6.4(a).

Box II Observations where unity of invention is lacking (Continuation of item 2 of first sheet)

This International Searching Authority found multiple inventions in this international application, as follows:

Please See Extra Sheet.

1. As all required additional search fees were timely paid by the applicant, this international search report covers all searchable claims.
2. As all searchable claims could be searched without effort justifying an additional fee, this Authority did not invite payment of any additional fee.
3. As only some of the required additional search fees were timely paid by the applicant, this international search report covers only those claims for which fees were paid, specifically claims Nos.:

4. No required additional search fees were timely paid by the applicant. Consequently, this international search report is restricted to the invention first mentioned in the claims; it is covered by claims Nos.:

I-13

Remark on Protest

- The additional search fees were accompanied by the applicant's protest.
- No protest accompanied the payment of additional search fees.

INTERNATIONAL SEARCH REPORT

International application No.
PCT/US99/02594

BOX II. OBSERVATIONS WHERE UNITY OF INVENTION WAS LACKING

This ISA found multiple inventions as follows:

This application contains the following inventions or groups of inventions which are not so linked as to form a single inventive concept under PCT Rule 13.1. In order for all inventions to be searched, the appropriate additional search fees must be paid.

Group I, claims 1-13, drawn to an illumination device.

Group II, claims 14-53 and 57-96, drawn to a device, and method for dissecting/harvesting tissue.

Group III, claims 54-56, drawn to a method of visualizing a vessel through a person's skin.

Groups I, II and III, the inventions listed as these groups do not relate to a single inventive concept under PCT Rule 13.1 because under PCT Rule 13.2 they lack the same or corresponding special technical features for the following reasons:

Group I, the invention of this group is limited to an illuminated device which may have numerous uses.

Group II, the invention of this group is directed to a dissection/harvesting device, and method with a specialized tip member for performing the procedures.

Group III, the invention of this group is directed to a method of locating a vessel through a person's skin, and may be performed with any number of lighted devices.