

April 26, 1966

J. F. HOWELL ETAL

3,248,603

MEAN FREE PATH GASEOUS DISCHARGE TUBE AND CIRCUIT THEREOF

Filed May 10, 1961

2 Sheets-Sheet 1

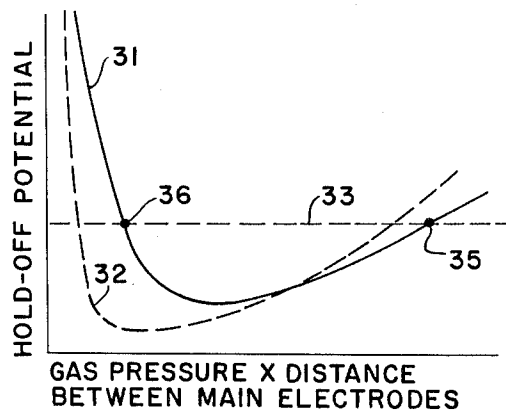
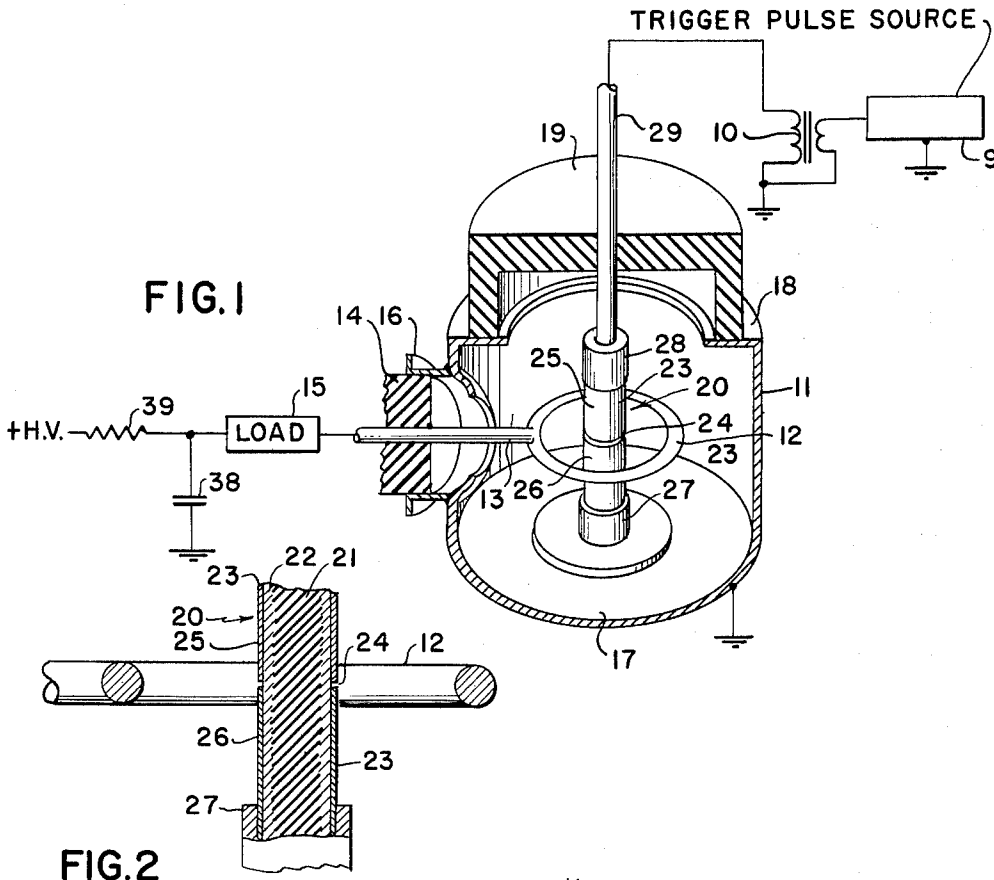

FIG. 3

INVENTORS
JOHN F. HOWELL
RALPH H. KALB
BY
Iwing Kayton
ATTORNEY

April 26, 1966

J. F. HOWELL ETAL

3,248,603

MEAN FREE PATH GASEOUS DISCHARGE TUBE AND CIRCUIT THEREOF

Filed May 10, 1961

2 Sheets-Sheet 2

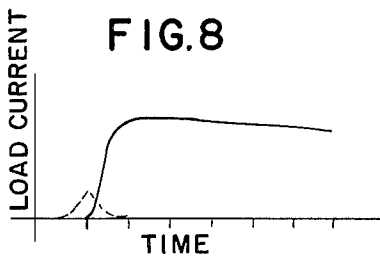
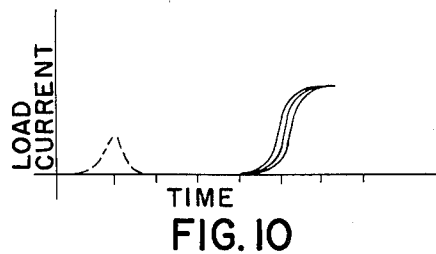
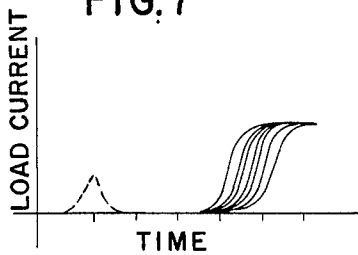
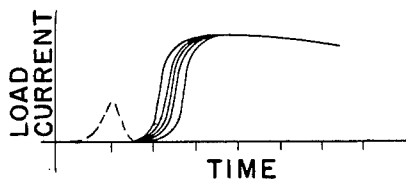
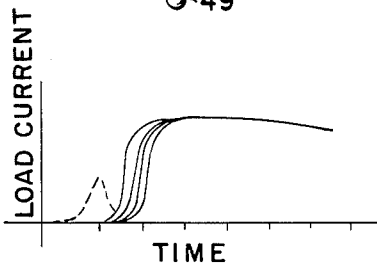
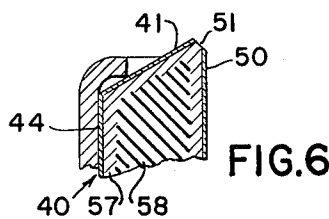
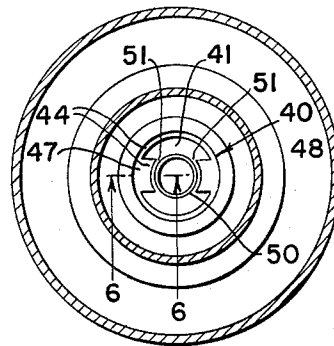
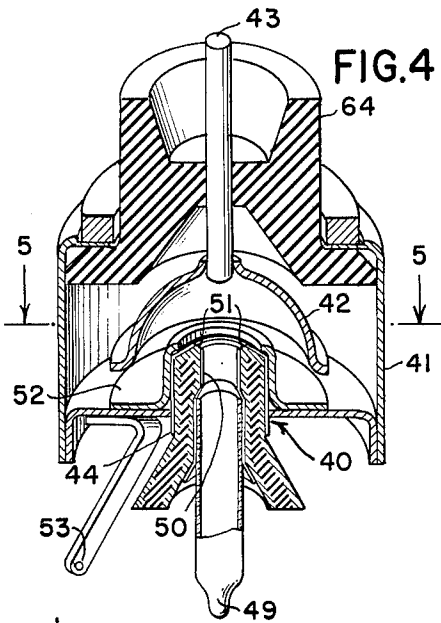

INVENTORS
JOHN F. HOWELL
RALPH H. KALB
BY
Irving Kayton
ATTORNEY

1

3,248,603

**MEAN FREE PATH GASEOUS DISCHARGE
TUBE AND CIRCUIT THEREOF**

John F. Howell, Waukesha, Wis., and Ralph H. Kalb,
Clearwater, Fla., assignors to General Electric Com-
pany, a corporation of New York

Filed May 10, 1961, Ser. No. 126,364
12 Claims. (Cl. 315-168)

This invention relates to a high voltage, high current switch, and particularly to such a switch, the operation of which is free of any moving parts.

Perhaps the only way adequately to convey the essence of something which is radically new is to compare it, in principle and in structure, with something already known, even though the differences between the new and the old are basic qualitative differences. The triggered spark gap tube as it is known in the art is probably the device with which the instant invention may best be compared, since its structure and operation provide a basis for properly comprehending the significant and novel aspects of the invention. Let us, therefore, briefly consider the principles of the triggered spark gap tube so that the principles of the instant invention may be properly referenced against them, and more readily comprehended thereby.

The triggered spark gap is an arc discharge device that functions as a high voltage switch; it employs the electrical breakdown or ionization of a gas within the tube in order to provide conduction. In essence, the triggered spark gap is a tube, the interior of which is filled with a gas which is capable of ionization (i.e., the breaking down into ions and electrons of an otherwise electrically neutral gas) when a sufficiently large voltage is applied between the two main electrodes.

Actually, the triggered spark gap comprises three electrodes; two of them, the two main electrodes, act as the figurative contacts of the switch, and the third acts to close this elemental switch by virtue of breaking down or ionizing, with a preparatory or initiating pulse, the gas disposed between the third electrode and one of the two main electrodes. The third electrode is spaced much more closely to one of the two main electrodes than are the two main electrodes spaced from each other. This close spacing is the reason why the potential applied between the third electrode and one of the main electrodes causes ionization with a smaller potential than that which would be required to break down the gas between the two main electrodes. The two main electrodes, which act as the contacts of the switch, are disposed opposite one another and are spaced from each other (insulated from each other) by a distance which is appropriate for the voltage of interest. That is to say, it is appropriate in the sense that conduction between the two main electrodes will not occur for the potential of interest that is applied across the two main electrodes without the aid of the action of the third electrode. The third or trigger electrode projects just through, and is insulated from, the surface of one of the two main electrodes. When the spark gap is to be switched, a short electrical pulse of suitable polarity is applied between the trigger electrode and the adjacent main electrode. This difference of potential is sufficient to break down these two closely spaced electrodes, whereby ionization takes place therebetween, thus allowing the main discharge to occur between the two main electrodes.

One theory advanced to explain the triggering of the triggered spark gap is that ultraviolet radiation which is generated by this localized breakdown serves to trigger the ionization of the rest of the gas in the gap, i.e., the rest of the gas between the two main electrodes. This results in an avalanche breakdown or ionization of the gas between the main electrodes. The ionized particles tend to move

2

toward the negative main electrode, while the electrons freed as a result of the ionization tend to move toward the positive main electrode. This action effectively serves to provide a conductive path between the two main electrodes, and the switch is thereby closed.

The completion of the conduction path between the two main electrodes does not occur instantaneously (although it does occur rapidly). The physical phenomenon responsible for the delay in the completion of the conduction path across the spark gap is of importance for an understanding of the operation of the instant invention. In the triggered spark gap, the pressure of the gas within the tube which serves the function of ionizing, and thereby forming the conductive path, ranges between one-half and one atmosphere of pressure. Under these circumstances, then, a large number of gas molecules and charged particles move at random between the two main electrodes. After the initial ionization caused by the breakdown between the trigger and one main electrode has occurred, the electrically charged particles tend to move in the direction of the electrode of opposite polarity. In moving to the oppositely poled electrode, however, they encounter other particles both charged and uncharged. The uncharged particles may be the molecules which have not yet been ionized. Because the motion of the particles before ionization is quite random, and because the molecules subsequent to ionization are dispersed at different points in the volume between the two electrodes, there is a very large probability that these charged particles, moving to their oppositely poled electrode, will be deflected from their straight line path to the electrode, either physically by an uncharged molecule, or electrically by a charged particle. This will hamper the completion of the conductive path between the electrodes. Since the larger the number of charged and uncharged particles that there is between the electrodes, the greater the probability that the charged particles will be deflected from their direct path to the oppositely poled electrode, it is understandable that the greater the gas pressure (and therefore density per unit volume) between the electrodes, the greater will be the delay in establishing the conductive path for a given distance between electrodes and for a given applied voltage across the electrodes.

For given pressure, temperature, and composition of gas, it is well known to be able to ascertain the average distance a molecule travels before it is deflected from its straight line path by other particles in the volume. This average undeflected distance, which is a statistical parameter, is termed the "mean free path." In the pressure range used for triggered spark gaps, approximately one-half to one atmosphere of pressure, the mean free path of a charged particle within the gap is much less than the physical distance between the two main electrodes.

From this basic fact, important consequences flow. Because of this relationship of the mean free path to the spark gap spacing, the characteristics and operational features of the triggered spark gap can be clearly related. Some of these characteristics are set forth in paragraphs 1 through 4 which follow immediately below, while the related but different features and advantages of the instant invention are interspersed therebetween as paragraphs 1A through 4A.

(1) The average delay between applying the triggering pulse and completing the conduction path, that is, firing the gap, may vary between .1 microsecond and tens of microseconds, depending upon the voltage applied between the main electrodes. The smaller delay time is attributable to higher voltages, since the momentum of the charged particle is greater due to the higher voltage; the particle is therefore less likely to be deflected substantially by other particles.

3

(1A) In accordance with the principles of the instant invention, however, the switch of the invention experiences no measurable delay at all. Thus, the application of a triggering pulse results in an instantaneous completion of a conduction path between the two main electrodes.

(2) Because the expression "mean free path" is obviously a statistical parameter, one can expect the actual free path to vary in magnitude about the value of the mean free path. Consequently, the actual delay varies in length with successive closings of the switch. Thus, for example, in the triggered spark gap having an average delay of one microsecond, the successive delays may vary as much as twenty-five percent about that figure with successive firings. This variation in the length of delay with successive pulsing of the spark gap is termed "jitter." Jitter is also a function of applied voltage, and in the triggered spark gap may range from .05 microsecond at the optimum applied voltage to several microseconds with an applied voltage only a couple of hundred volts away from the optimum applied voltage.

(2A) In accordance with the instant invention, however, there is literally no measurable variation in the delay, since there is in fact no measurable delay. Any variation in the time to complete the conduction path subsequent to the application of the pulse, is due solely to external circuit parameters which vary the timing of the triggering pulse itself. In short, there is no measurable jitter to be observed.

(3) The voltage which a triggered spark gap will switch can vary to a certain extent. Thus, a triggered spark gap designed to switch, for example, ten kilovolts, may operate with increasing jitter and unreliability down to about five or six kilovolts. Below that, however, no switching action occurs at all. Therefore, the approximate range of the supply voltage that can be expected for switching a triggered spark gap is about two to one.

(3A) In accordance with the principles of applicants' invention, however, efficient switching has been obtained consistently with variations in the supply voltage from fifty volts to thirty kilovolts without any deterioration in other tube performance parameters. In short, practically any voltage will be switched up to the maximum voltage of which the tube is capable. This dynamic range is unequalled in any other electrical switching device known in the art.

(4) Practically by definition, the dimensions of the spark gap, that is, the spark distance or distance between electrodes, and the pressure of the gas therebetween are critical parameters. "For spherical terminals, the relation is so definite that the 'sphere gap' is often used as a rough measure of high voltages. Thus with spherical electrodes five centimeters in diameter, a two centimeter spark in air at normal pressure corresponds to a potential difference of 56,300 volts; a five centimeter gap to 102,250 volts." International Dictionary of Physics and Electronics, D. Van Nostrand & Co., Inc., 1956. Thus, in triggered spark gaps, the distance between gaps, the shapes of the gaps and the pressure of the gas in the gaps are all critical in determining the switching voltage and the other operating parameters mentioned above.

(4A) In accordance with the principles of the instant invention, however, the shape and spacing between electrodes are actually matters of very little moment (except for the maximum voltage the tube can hold-off). Similarly, the pressure of the gas used in the gap can vary over wide ranges without adversely affecting the operation of the device. The electrodes may be rough or smooth, they may be cylindrical or spherical, they may be skewed and irregular, and essentially the same operating results are satisfactorily obtained.

These differences are more than just abstract advantages. Consider the advantage of items 1A and 2A above, wherein there is effectively no delay or jitter. This permits the simultaneous firing or switching of a

4

parallel array of devices with the application of a single pulse to a multiplicity of switches, in accordance with the principles of the invention. There are certain applications where this precise simultaneous firing may be of considerable importance; typical are seismological applications, and other types of time dependent systems. In time dependent systems, it is often the case that a control pulse may be applied to a triggered spark gap and to another device, wherein a delay must be introduced in the circuit of the second device so that the firing of the triggered spark gap may be synchronized with the operation of the other control device. In accordance with the switch of the instant invention, the need to introduce either a coaxial or lumped parameter delay circuit in the system is eliminated.

The tremendous operating voltage range of the switch in accordance with the invention as indicated in paragraph 3A, permits the utilization of voltage supply sources that may ordinarily be subject to considerable variation with ambient conditions. For example, wide temperature variations may result in wide voltage ratings for a battery that may be part of the circuit. Nevertheless, switching can be performed in accordance with the instant invention because of the tremendous dynamic voltage range of the switch (50 volts being the practical lower limit encountered). Concomitantly, the need for voltage regulators in the circuit is eliminated, since the switch will operate regardless of the level of the applied voltage. Considerable circuit savings are thereby possible.

The advantages derived from item 4A above are very practical, since the need for time and effort ordinarily spent on quality control in mass production is essentially eliminated. It would require a very simple type of quality control to maintain the relationships and structure of the switch in accordance with the invention, within acceptable limits. Indeed, mere viewing of the device by eye should suffice. The cost reduction in the mass production of such a device can be tremendous, not only in terms of the manpower and effort saved in applying quality control, but in the reduction of rejected tubes that can be expected with any quality control program.

Another advantage which flows from item 4A above is the fact that one of the electrodes may be shaped as the external envelope of the tube, and because it is metal, may provide electrical shielding for the whole device. Thus, one of the electrodes may itself serve the function of an electrical shield.

Furthermore, measurements have demonstrated that the voltage drop across the gap of the switch in the conducting state, in accordance with the invention, is substantially the same as that across a comparable triggered spark gap tube. Since the efficiency of the device is directly proportional to this voltage drop, it is clear, then, that the efficiency of the switch in accordance with the invention is effectively the same as that of the triggered spark gap.

The above advantages and features of the instant invention have been achieved because of two basic characteristics of the switch in accordance with the invention. Firstly, the pressure of the gas in the gap of the switch need meet only one requirement, namely, that its pressure be low enough such that the mean free path of charged gas particles within the gap be substantially greater than the physical distance between the two main electrodes. In this connection, it should be understood that the geometry and spacing of the two electrodes is relatively unimportant. With whatever geometry and spacing is used, the pressure of the gas must be low enough such that this mean free path is greater than the gap dimension.

This requires that the gas pressure in the device, in accordance with the principles of the invention, be considerably lower than in the triggered spark gap. Although this means that relatively few molecules occupy

5

the gap volume, this is of no consequence since reliance for ions and electrons is not placed primarily upon the gas itself. Quite to the contrary, the source of charged particles is derived from a completely different physical arrangement; and this arrangement is the second basic aspect of the invention.

The primary source of charged particles is derived from a reversible electrical breakdown of the insulator between two closely spaced trigger electrodes. By applying a sufficiently high potential across the two closely spaced electrodes (one electrode of which is at the same reference potential as one of the two main electrodes), the insulator effectively breaks down across its surface and generates a cloud of ions and electrons. This cloud of charged particles serves as the main source of charged particles for forming the conductive path between the two main electrodes. Secondary emission from the switch electrodes and ionization of the little gas that may exist within the gap also contribute.

Without the application of the triggering pulse, the gap between the main electrodes will break down if a sufficiently high potential is applied therebetween. The relationship for the minimum voltage that will cause a breakdown is known as "Paschen's Law" and is well known to those skilled in the art. Expressly, it indicates that this "hold-off potential" is directly proportional to the product of pressure and distance between main electrodes (for any particular gas). In the switch of the instant invention, it is, of course, necessary to make sure that the requirements of Paschen's Law are satisfied so that the gap does not break down at some voltage below the maximum switching voltage of interest. This, however, is a condition easily met within the confines of the requirement that the mean free path of the charged particles be greater than the distance between the main electrodes. More specifically, Paschen's Law may be represented by a curve which has as its ordinate the hold-off voltage, and as its abscissa the product of pressure and distance between electrodes. As will be described in greater detail below, this curve is concave upwards and has one minimum point in it. The physical structure of the well-known triggered spark gap is described by a point on the curve to the right of this minimum, and in all cases pressures of one-half to one atmosphere are in this range to the right. The physical structure of the instant invention, however, is described by a point to the left (the low pressure side) of the minimum of Paschen's curve, which also satisfies the requirement that the mean free path of the charged particles be substantially greater than the gap distance.

The switch in accordance with the invention can be substituted for every application wherein a triggered spark gap is used, as well as in many others. There are certain thyatron and ignitron applications wherein the switch of the instant invention may well be substituted, and in certain applications the mere decrease in physical size of the instant switch over that of the thyatron and ignitron would indicate its use if for no other purpose than that.

The novel features which we believe to be characteristic of our invention are set forth with particularity in the appended claims. Our invention itself, however, both as to its organization and method of operation, together with further objects and advantages thereof, may best be understood by reference to the following description taken in connection with the accompanying drawings.

In the drawings:

FIGURE 1 is a cut-away perspective view of a switch in accordance with the invention;

FIGURE 2 is a cross-sectional view of the trigger electrodes of the switch of FIGURE 1;

FIGURE 3 is a graphical representation of Paschen's Law, well known in the art, and useful in explaining an important physical parameter of the invention;

FIGURES 4, 5 and 6 are views of another switch in

6

accordance with the invention having a different geometry from that of FIGURES 1 and 2;

FIGURES 7 through 10 are graphical representations of the variations in certain performance criteria of a prior art switch; and

FIGURE 11 is a graphical representation for the switch of the instant invention, of the same performance criteria as represented in FIGURES 7 through 10.

Referring to FIGURE 1 in greater detail, there is shown a cut-away view of an illustrative embodiment, given by way of example, of a switch in accordance with the invention, with external leads connected to a schematically represented external triggering and load circuit, which is typical of the applications for high current switches. The switch comprises as its basic elements a positive and negative electrode, trigger electrodes and the gas pressure within the vacuum-tight tube.

The negative electrode of the tube of FIGURE 1 is a metallic cylindrical envelope 11 forming the major external portion of the tube. Cylinder 11 has a bottom face 17 and a top face 18 as well as its cylindrical walls. Because of the high current supported by the switch, negative electrode 11 is preferably made of a metal having a high melting point such as tantalum or molybdenum.

The positive electrode is in the form of an annular metal ring 12 disposed with the plane of the ring parallel to the bottom face of envelope 11. A rod 13, secured at one point on the ring, extends out through an aperture in the cylindrical wall of electrode 11. Rod 13 is supported in an insulator 14 and is thence connected to an external load circuit 15. The positive electrode is in this way physically secured and fixed within negative electrode 11, and is spaced and electrically insulated therefrom. Insulator 14 is supported in turn, relative to the aperture in envelope 11, by a bushing 16.

The insulator 14 is preferably a ceramic material capable of withstanding high temperatures. A particularly desirable ceramic of this type comprises ninety-five percent Al_2O_3 , with the remaining five percent comprising Cr_2O_3 , SiO_2 , MgO and CaO . A commercially available ceramic having this composition goes under the trade name of "Diamonite," P3142-1.

Positive electrode 13 must also be of a metal which can withstand high temperatures, and similarly may be of molybdenum or tantalum, although Kovar also has been found excellent for this purpose.

Top face 18 of envelope 11 has a centrally disposed aperture therein which, as will be seen serves to permit the penetration therethrough of the lead from one of the trigger electrodes. A straddle the top of face 18 is a ceramic cap 19 which serves to completely close the envelope otherwise formed by negative electrode 11. Ceramic cap 19 may similarly be of the ceramic material described above.

The structure thus far described forms a vacuum or hermetically sealed container. Thus, negative electrode 11, insulator 14 with its bushing 16 secured in the wall of electrode 11, and cap 19 disposed at the top of face 18 may be joined together by suitable brazing techniques well known for these types of metals and ceramics, so as to make a completely vacuum-tight seal. For details on particularly advantageous brazing techniques, reference may be had to the copending application of John M. Morgan and Joseph B. Kubeck, Serial No. 84,660, filed January 24, 1961, entitled "Method for Constructing Arc Discharge Devices," which issued on July 17, 1962, as United States Patent No. 3,045,093.

The trigger electrodes comprising rod 20 are disposed along the longitudinal axis of cylindrical electrode 11. The details of the negative electrodes and rod 20 are presented more clearly in the detailed cross-sectional view of FIGURE 2. Rod 20 comprises three concentric or coaxial layers. Ceramic rod 21 forms the core upon which the other layers are formed. This rod, too, is preferably of the ceramic mentioned above. A layer 22

is formed about ceramic rod 21 by metallizing the external layer with a combination of molybdenum and manganese. External to layer 22 is a metallic layer 23 which is preferably of titanium or molybdenum, and which may be vacuum-deposited upon the outer surface of metallized layer 22. A circumferential groove 24 is cut around rod 20, so as to penetrate solely the external metal layer 23. The disposition of circumferential groove 24 is concentric with positive electrode 12. Groove 24, then, effectively divides rod 20 into two separate trigger electrodes, 25 and 26.

To obtain some idea of the relative sizes of the layers, the groove and the other physical objects of the switch, the following are appropriate, but by no means critical, dimensions. With the device operating as a 10 kilovolt switch, rod 20 may be .06 of an inch in diameter, with the metallized layer 22 less than .001 of an inch thick, and the circumferential groove having a width (which serves to space electrodes 25 and 26 from each other) of .001 to .008 of an inch.

The trigger electrodes of which rod 20 is comprised are mounted within negative electrode 11 in the vertical position mentioned above. The lower part of trigger electrode 26 is secured in a grommet-like fixture 27, which is in turn secured to the bottom face 17 of electrode 11. A similar grommet-like fixture 28 is secured to the top portion of trigger electrode 25. It may be seen from this that trigger electrode 26 is at the same electrical potential as is the negative electrode 11. Coupled to trigger electrode 25 is electrical lead 29, which exits the tube through the aperture in face 18, and through a centrally disposed aperture in ceramic cap insulator 19. A triggering potential may be applied between electrodes 25 and 26 by virtue of trigger pulse source 9, which through step-up pulse transformer 10 is coupled to conductor 29 relative to trigger electrode 25, and to the grounded negative electrode 11 in electrical contact with trigger electrode 26.

The vacuum-tight structure of the switch is evacuated of gas to a very low pressure. It is preferable that an inert gas be in the tube at whatever pressure is used so as to avoid chemical reaction between the gas and the metal electrodes at the high temperatures characteristic of switch operation. Typical and appropriate inert gasses are helium, nitrogen, krypton and xenon. However, hydrogen and air have each been used with relatively satisfactory results. The pressure of the gas is preferably in the micron region, e.g., 100 microns of nitrogen, 500 microns of helium, 8 microns of air. The pressure selected is a function of the particular gas, and the hold-off potential required for any given tube, as will be understood from the discussion relative to FIGURE 3 to be presented below.

Techniques for evacuating tubes such as triggered spark gap tubes are well known in the art and will not be discussed here. Reference may be had, however, to the co-pending patent application of Edward E. Hafkemeyer and Robert E. Hueschen, Serial No. 87,048, filed December 29, 1960, entitled "Arc Discharge Device," wherein evacuation of a related type tube is described.

Disclosed in FIGURE 3 is a typical representation of the Paschen curve mentioned above. The ordinate represents the hold-off potential in volts, while the abscissa is the product of gas pressure and the shortest distance between the main electrodes of the gap. Curve 31 is a typical Paschen curve, and is the curve characteristic of helium. It may be noted that this curve, which is concave upward, approaches the ordinate asymptotically; moving to the right along the abscissa, the hold-off voltage decreases to a minimum point and then once again increases to the right. The curves of different gasses are disposed differently, but the basic outline remains the same. Thus, for example, curve 32 is the Paschen curve for nitrogen. Curve 32 approaches the ordinate asymptotically more rapidly than does curve 31, and the minimum point is

displaced from that of helium curve 31. However, the curves are qualitatively the same.

With reference to curve 31, horizontal line 33 passes through the curve at two points and intersects the ordinate at a particular hold-off potential. Let us draw line 33 at the ten kilovolt hold-off level. Thus, there are two pressures of helium for which a given switch with a fixed distance between the main electrodes can provide the required hold-off potential, i.e., the pressure at point 36 to the left of the minimum point of the Paschen curve and the pressure at point 35 to the right. The pressure at point 35 is appropriate for the prior art triggered spark gap and is ordinarily in the range between one-half and one atmosphere of helium (the exact figure depending upon the electrode spacing). This provides a sufficient density of particles such that the gas may be readily ionized to form the conduction path. In this pressure range, however, the gas is sufficiently dense such that the mean free path of any particle in a triggered spark gap is substantially less than the actual distance between the main electrodes. At point 36, however, the pressure may well be in the order of 500 microns. At this pressure, there is a very sparse distribution of helium molecules in the tube in accordance with the invention, and accordingly the mean free path of particles within the tube is considerably greater than the fixed distance between the main electrodes. Such a condition is appropriate only in the switch of the instant invention, since the ions and electrons relied on for initiating the conduction path are not obtained primarily from the gas itself, but from the surface insulator breakdown between the trigger electrodes.

The operation of the circuit and switch of FIGURE 1 may now be properly comprehended. A trigger pulse from source 9, which may be appropriately of the order of 600 to 3,000 volts, is applied via pulse transformer 10 to the trigger electrodes 25 and 26 within the tube. It is relatively immaterial whether trigger electrode 25 is positive or negative relative to trigger electrode 26. Irrespective of which polarity is applied, the triggering function will be performed equally well under most conditions. The difference of potential applied across the groove 24 between the trigger electrodes 25 and 26 results in an electrical breakdown across the surface of the metallized ceramic layer 22 located within the groove 24. This results in the generation of a cloud of ions and electrons which are responsible primarily for forming the conduction path between positive electrode 12 and negative electrode 11. In addition to this breakdown, secondary emission from the main electrodes and ionization of whatever gas there is within the gap also contribute to conduction during the switching period; as a consequence the pressure within the tube is appreciably increased during this dynamic switching period. Thus, the high voltage switch changes from an essentially non-conducting state to a state of high conduction with the application of the trigger pulse. Energy which is stored in capacitor 38 (in shunt with the positive and negative electrodes of the switch) flows through load 15 and through the high current switch itself. Resistor 39, in series with load 15 and the positive and negative electrodes of the switch, serves as a charging path for capacitor 38, and as isolation between the external circuit shown and the charging supply during the discharge period.

The high voltage applied between the terminal of resistor 39 and the negative electrode 11 of the switch may typically be 10,000 volts, although applications have been successfully utilized in accordance with the invention to 30,000 volts, and there is no reason now known why larger potentials may not be readily switched in accordance with the invention. With the tubes designed to operate at these potentials, satisfactory switching has been achieved with applied potentials of as low as 50 volts without any demonstrable change in the performance of the tube, even though an oscilloscope with a .1 micro-

second per centimeter sweep was used to analyze performance.

The trigger electrodes 25-26 were described as spaced from each other by groove 24 with the surface of metallized ceramic layer 22 therebetween. It should be understood that it is not necessary (but it is desirable) to metallize the ceramic prior to use of the switch. With the trigger electrodes spaced by the ceramic without metallization, the device operates satisfactorily provided that a somewhat higher potential triggering pulse be applied between the trigger electrodes. This causes switching in the manner described above. In this process, a certain amount of metallic sputtering from the electrodes develops, and metallization of the ceramic occurs in the insulated area between trigger electrodes as a result of the ordinary use of the tube. After sputtering performs the metallizing function, the trigger pulse required to fire the tube is once again at the level appropriate for the metallized ceramic.

From the description of the operation of the circuit and the switch of FIGURE 1, it may be seen that a single trigger pulse may be applied simultaneously to a multiplicity of switches, each one of which may control a separate and independent external circuit, including its own separate and independent load. Simultaneous switching occurs in this way irrespective of possible different impedances in the different external circuits and irrespective of different potentials that may be applied in each of the multiplicity of circuits. Furthermore, because of the dynamic operating range of the tubes, the same type tubes may be used for all of the different circuits irrespective of what applied voltage is used for each one of the circuits. Thus, unlike the triggered spark gap where it would be necessary to have different main electrode spacings for switching different potentials in different circuits, it is entirely appropriate to use the very same kind of tube with the same electrode spacing for any number of circuits having applied potentials that require switching from, for example, 50 volts to 30,000 volts.

Referring now to FIGURE 4, there is disclosed an alternative form of a switch in accordance with the principles of the invention. This switch, and that of FIGURE 1, are, in most respects, similar, but the geometry of the positive electrode and the geometry of the triggering electrodes are substantially different in FIGURE 4.

It may be noted that the negative electrode 41 of FIGURE 4 is a hollow cylindrical shell similar in shape to the negative electrode of FIGURE 1. The positive electrode 42 is hemispherical in shape, unlike the ring electrode 12 of FIGURE 1, but is mounted within cylinder 41 in approximately the same position. An external lead 43 is secured to positive electrode 42, and passes upwardly out through the tube to be coupled to the external circuit which is not shown. The external circuit, however, may be the same as that shown in FIGURE 1; thus, lead 43 may be connected to the load circuit, such as load 15 of FIGURE 1. A cylindrical insulator 64, preferably of the ceramic discussed above, serves to close the top of the tube through which lead 43 from the positive electrode passes out of the tube. In this way, the insulator 64 serves to space and electrically insulate the negative electrode portion at the top of cylinder 41 from positive electrode lead 43. This ceramic material may be brazed to the cylindrical negative electrode as discussed above relative to FIGURE 1.

The trigger electrodes of FIGURE 4 have a substantially different geometry from that of FIGURE 1. The trigger electrode assembly comprises hollow cylinder 40, a portion of which is shown in cross-sectional view in FIGURE 6, and the top view of which is shown in the cross-sectional view of FIGURE 5 taken along line 5-5 of FIGURE 4. The top surface of cylinder 40 conforms to a conical shape, with the hollow bore portion of the cylinder at the center thereof. The outer surface of the cylindrical walls and the inner surfaces forming the bore

of cylinder 40 are covered, as by vacuum deposition, with an appropriate metal such as titanium or molybdenum. As can be seen from FIGURES 5 and 6, metal deposit 44 on the external surfaces of the cylinder also occupies a portion of the conical surface at the top of the cylinder. Metal layer 44 in two extended sections, 47 and 48, occupies part of the surface of the conical section right up to, but just short of, the apex ridge of the conical section. This external metal layer 44 is one of the two trigger electrodes.

The other of the two trigger electrodes is metal layer 50 disposed on the inside bore surface of the cylinder 40. Metal layer 50 which coats the bore hole wall of cylinder 40 extends the length of the bore right up to, but just short of, the apex ridge of the conical top surface of the cylinder. Thus, trigger electrodes 44 and 50 are spaced from each other a minute distance fixed by the chamfered edge 51 of the apex ridge of the conical section at the top of cylinder 40. The distance between electrodes 44 and 50 across chamfered edge 51 may typically be between .001 and .008 of an inch, as was the width of circumferential groove 24 of FIGURE 1. This close spacing occurs, however, only along sections 47 and 48 of electrode 44. Trigger electrode 50 is in physical contact with external lead 49, which in turn may be coupled to the external circuit, and in particular to a source of triggered pulses. Electrode 44 is in physical contact with a cap 52, in turn physically secured to the bottom face of negative electrode cylinder 41, which in turn may be grounded, as was the case in the embodiment of FIGURE 1.

Although a trigger electrode in each of the embodiments of FIGURES 1 and 4 is shown to be physically connected to the main negative electrode, such physical contact is not necessary. All that is required is that one trigger electrode be at approximately the same reference potential as is the negative main electrode. An electrical lead 53 is coupled to the negative main electrode 41. The triggering pulse may therefore be applied across the terminals 49 and 53 in order to apply the potential across trigger electrodes 50 and 44.

The precise structure of the trigger electrodes may be seen from the view of FIGURE 6. Metal layer 50, forming one of the trigger electrodes, is shown in cross-section on the inside surface of the cylinder bore hole, while the metal layer 44 which is the other trigger electrode is on the outside surface of the cylinder and its top conical portion. Metallized ceramic layer 57 is interposed between trigger electrode layers 44 and 50 on the one hand, and the inner ceramic insulator 58 upon which the metallized layer 57 and the trigger electrodes are disposed.

The gas within the body of the tube is as was described with reference to FIGURE 1 and satisfies the requirements of the description relative to FIGURE 3.

In the operation of this tube, the main conduction path is between the top of cap portion 52 secured to and part of the negative electrode 41, and the inside face of hemispherical positive electrode 42. This geometry is particularly advantageous in that metallization that develops from sputtering because of conduction between the electrodes is precluded from forming on the lower surface of the ceramic insulator 64. In this way, electrical isolation between negative electrode cylinder 41 and lead 43 to positive electrode 42 is maintained.

The electrode geometries shown in FIGURES 1 and 4 are, of course, merely examples. Literally dozens of other geometries may be utilized readily within the purview of the invention and in accordance with its principles. Certain geometries may have different ancillary advantages, as is the case with the geometry of the electrodes of FIGURE 4, wherein an undesirable effect of sputtering is substantially eliminated. The principle, however, remains the same. Thus, in the embodiment of FIGURE 4, it is the breakdown of the layer along the region 51 in between the metal trigger electrodes 44 and 50 which

provides the cloud of electrons and ions required for the conduction path, just as it was the metallized ceramic in the narrow groove 24 between trigger electrode segments 25 and 26 in FIGURE 1.

The curves of FIGURES 7 through 10 are presented to show the delay and jitter characteristic of a good and typical prior art triggered spark gap tube, for comparison with these parameters in the tube in accordance with the invention. The broken line curve is the trigger pulse and the solid line curves show condition across the main electrodes in time relation to the pulse. Each interval on the axis represents 0.1 of a microsecond. These curves are representations of actual oscilloscope photographs.

FIGURES 7 and 9 show the switching of a triggered spark gap with 2,200 volts applied between the main electrodes. FIGURE 7 shows several firings or shots taken after the first 50 firings, while FIGURE 9 shows several shots taken after the first 150 shots. Aside from the fact that there is delay (the time between the peak of the dotted curve and the steep edge of the conduction curve) and considerable jitter in both figures, it may be noted that the delay is greater after 150 shots than after 50 shots. This increase in delay with the number of firings is characteristic of triggered spark gap operation.

FIGURES 8 and 10 show these characteristics with 1,800 volts applied between main electrodes. At this lower potential, the delay is clearly longer than at 2,200 volts. Furthermore, the delay for FIGURE 10, after 150 shots is longer than for FIGURE 8 after 50 shots.

FIGURE 11 presents curves for the switch in accordance with the invention. This is what the oscilloscope showed both at 2,200 volts and at 1,800 volts switching potential, and after 50 and 150 shots at each voltage. It may be noted that there is literally no delay in FIGURE 11 (within the measuring capacity of the equipment) and there is no jitter. This performance is characteristic of the switch of the invention.

While we have shown particular embodiments of our invention, it will be understood that many modifications may be made without departing from the spirit thereof, and we contemplate by the appended claims to cover any such modifications as fall within the true spirit and scope of our invention.

What we claim is:

1. A switch comprising: positive and negative main electrodes with a given inter-electrode distance therebetween, said electrodes being disposed within a vacuum-tight container; the gas pressure within said container being sufficiently low such that the mean free path of gas particles within said container is greater than said inter-electrode distance; and means for generating electrons and ions in said container independently of said main electrodes and independently of any gas within said container to provide a conductive path between said positive and negative main electrodes.

2. A switch as recited in claim 1, wherein the gas within said container is inert gas.

3. A switch comprising: positive and negative main electrodes with a given inter-electrode distance therebetween, said electrodes being disposed within a vacuum-tight container; the gas pressure within said container being sufficiently low such that the mean free path of gas particles within said container is greater than said inter-electrode distance; and means for generating electrons and ions in said container independently of any gas within said container to provide a conductive path between said positive and negative main electrodes, said means for generating electrons and ions comprising first and second electrodes spaced a short distance from each other by an insulator and disposed adjacent said electrodes; and means for applying a difference of potential between said first and second electrodes.

4. A switch as recited in claim 3, wherein the surface of said insulator is metallized.

5. A switch comprising: electrodes having an inter-electrode distance between the positive and negative main electrodes, said electrodes being disposed within a vacuum-tight container; means for generating electrons and ions in said container independently of said main electrodes and independently of any gas within said container to provide a conductive path between said positive and negative main electrodes; the gas within the container having a pressure which when multiplied by said inter-electrode distance defines a point on the low pressure side of the Paschen curve for said gas.

6. A switch as recited in claim 5, wherein said negative main electrode is cylindrical in shape and forms the bottom, sides and part of the top of said vacuum-tight container, whereby said negative electrode provides an electrical shield for everything within its volume.

7. A switch comprising: electrodes having an inter-electrode distance between the positive and negative main electrodes, said electrodes being disposed within a vacuum-tight container; means for generating electrons and ions in said container independently of any gas within said container to provide a conductive path between said positive and negative main electrodes; said means for generating electrons comprising first and second trigger electrodes spaced from each other by an insulator and disposed adjacent said positive and negative electrodes; said spacing between trigger electrodes being smaller than said inter-electrode distance; and means for applying a difference of potential between said trigger electrodes; the gas within said container having a pressure which when multiplied by said inter-electrode distance defines a point on the low pressure side of the Paschen curve for said gas.

8. A switch as recited in claim 7, including means for applying a difference of potential between said positive and negative main electrodes greater in magnitude than said difference in potential applied between said trigger electrodes.

9. A switch as recited in claim 7, wherein one of said trigger electrodes and said negative main electrode are electrically connected to the same level of electrical potential.

10. A switch comprising: positive and negative main electrodes with a given inter-electrode distance therebetween, said electrodes being disposed within a vacuum-tight container; the gas pressure within said container being sufficiently low such that the mean free path of gas particles within said container is greater than said inter-electrode distance; and means for generating electrons and ions in said container independently of said main electrodes and to provide a conductive path between said positive and negative main electrodes, said electron and ion generating means being independent of the gas within said container.

11. A switch comprising: positive and negative main electrodes with a given inter-electrode distance therebetween, said electrodes being disposed within a vacuum-tight container; the gas pressure within said container being sufficiently low such that the mean free path of gas particles within said container is greater than said inter-electrode distance; and means for generating electrons and ions in said container to provide a conductive path between said positive and negative main electrodes, said electron and ion generating means being independent of the gas within said container and comprising first and second electrodes spaced a short distance from each other by an insulator and disposed adjacent said positive and negative electrodes; and means for applying a difference of potential between said first and second electrodes.

12. A switch comprising: positive and negative main electrodes with a given inter-electrode distance therebetween disposed within a vacuum-tight container; the gas pressure within said container being sufficiently low such

13

that the mean free path of gas particles within said container is greater than said inter-electrode distance; means for generating electrons and ions in said container to provide a conductive path between said positive and negative main electrodes, said means for generating electrons and ions comprising first and second electrodes spaced a short distance from each other by an insulator and adjacent said main electrodes; a metallized surface on said insulator; and means for applying a difference of potential between said first and second electrodes.

References Cited by the Examiner

UNITED STATES PATENTS

1,871,279	8/1932	Rentschler	-----	313—198
1,948,720	2/1934	Knowles	-----	313—200

14

2,340,799	2/1944	Depp	-----	313—200 X
2,409,716	10/1946	Slack et al.	-----	313—200 X
2,535,886	12/1950	Baker et al.	-----	313—194 X
2,817,036	12/1957	Neal	-----	313—198 X
2,909,695	10/1959	Melhart	-----	313—197
2,935,648	5/1960	Buntenbach	-----	315—168 X
2,987,641	6/1961	Wegmann	-----	313—194 X
3,087,092	4/1963	Lafferty	-----	315—168 X

10

GEORGE N. WESTBY, *Primary Examiner.*

KATHERINE CLAFFY, DAVID J. GALVIN,

Examiners.

15

C. R. CAMPBELL, *Assistant Examiner.*