

(12) INTERNATIONAL APPLICATION PUBLISHED UNDER THE PATENT COOPERATION TREATY (PCT)

(19) World Intellectual Property Organization  
International Bureau



(43) International Publication Date  
13 March 2003 (13.03.2003)

PCT

(10) International Publication Number  
**WO 03/021898 A1**

(51) International Patent Classification<sup>7</sup>: **H04L 12/56**

(21) International Application Number: PCT/US02/25865

(22) International Filing Date: 13 August 2002 (13.08.2002)

(25) Filing Language: English

(26) Publication Language: English

(30) Priority Data:  
09/944,887 31 August 2001 (31.08.2001) US

(71) Applicant: **MOTOROLA, INC.** [US/US]; 1303 East Algonquin Road, Schaumburg, IL 60196 (US).

(72) Inventors: **REMBOSKI, Donald, J.**; 160 Golf Crest Drive, Dearborn, MI 48124 (US). **REINOLD, Juergen**; 705 Woodland Road, Palatine, IL 60074 (US).

(74) Agents: **KOCH, William, E.** et al.; Motorola Labs, 3102 North 56th Street, AZ11/56-238, Phoenix, AZ 85018-6606 (US).

(81) Designated States (*national*): AE, AG, AL, AM, AT, AU, AZ, BA, BB, BG, BR, BY, BZ, CA, CH, CN, CO, CR, CU, CZ, DE, DK, DM, DZ, EC, EE, ES, FI, GB, GD, GE, GH, GM, HR, HU, ID, IL, IN, IS, JP, KE, KG, KP, KR, KZ, LC, LK, LR, LS, LT, LU, LV, MA, MD, MG, MK, MN, MW, MX, MZ, NO, NZ, OM, PH, PL, PT, RO, RU, SD, SE, SG, SI, SK, SL, TJ, TM, TN, TR, TT, TZ, UA, UG, UZ, VC, VN, YU, ZA, ZM, ZW.

(84) Designated States (*regional*): ARIPO patent (GH, GM, KE, LS, MW, MZ, SD, SL, SZ, TZ, UG, ZM, ZW), Eurasian patent (AM, AZ, BY, KG, KZ, MD, RU, TJ, TM), European patent (AT, BE, BG, CH, CY, CZ, DE, DK, EE, ES, FI, FR, GB, GR, IE, IT, LU, MC, NL, PT, SE, SK, TR), OAPI patent (BF, BJ, CF, CG, CI, CM, GA, GN, GQ, GW, ML, MR, NE, SN, TD, TG).

**Published:**

- with international search report
- before the expiration of the time limit for amending the claims and to be republished in the event of receipt of amendments

For two-letter codes and other abbreviations, refer to the "Guidance Notes on Codes and Abbreviations" appearing at the beginning of each regular issue of the PCT Gazette.

(54) Title: VEHICLE ACTIVE NETWORK WITH REDUNDANT DEVICES

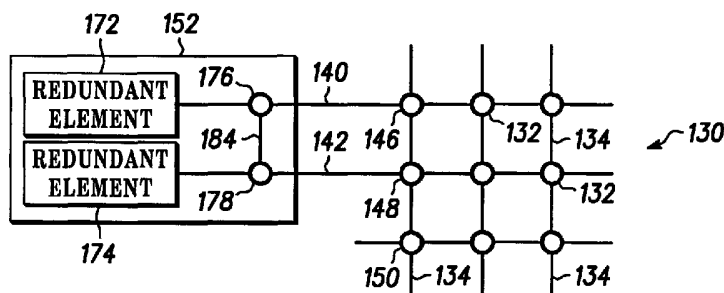

(57) Abstract: A vehicle active network (12) communicatively couples devices (14-20) within a vehicle (10). Device operation is independent of the interface (22-28) of the device (14-20) with the active network (12). Additionally, the architecture of the active network (12) provides one or more levels of communication redundancy. The architecture provides for the total integration of vehicle systems and functions, and permits plug-and-play device integration and upgradeability.



WO 03/021898 A1

## VEHICLE ACTIVE NETWORK WITH REDUNDANT DEVICES

**Related Applications**

The present invention is related to the following applications which are assigned to  
5 the same assignee as the present invention:

VEHICLE ACTIVE NETWORK, Attorney Docket Number IA00001, filed August  
31, 2001, having Serial Number 09/945,581;

VEHICLE ACTIVE NETWORK WITH RESERVED PORTIONS, Attorney Docket  
Number IA00002, filed August 31, 2001, having Serial Number 09/944,892;

10 VEHICLE ACTIVE NETWORK WITH DATA REDUNDANCY, Attorney Docket  
Number IA00003, filed August 31, 2001, having Serial Number 09/943,908;

VEHICLE ACTIVE NETWORK WITH COMMUNICATION PATH  
REDUNDANCY, Attorney Docket Number IA00004, filed August 31, 2001, having Serial  
Number 09/943,870;

15 VEHICLE ACTIVE NETWORK ADAPTED TO LEGACY ARCHITECTURE,  
Attorney Docket Number IA00005, filed August 31, 2001, having Serial Number  
09/945,585;

VEHICLE ACTIVE NETWORK WITH FAULT TOLERANT DEVICES, Attorney  
Docket Number IA00006, filed August 31, 2001, having Serial Number 09/943,882;

20 LINKED VEHICLE ACTIVE NETWORKS, Attorney Docket Number IA00007,  
filed August 31, 2001, having Serial Number 09/944,653;

VEHICLE ACTIVE NETWORK WITH DATA ENCRYPTION, Attorney Docket  
Number IA00008, filed August 31, 2001, having Serial Number 09/944,883;

25 VEHICLE ACTIVE NETWORK WITH BACKBONE STRUCTURE, Attorney  
Docket Number IA00010, filed August 31, 2001, having Serial Number 09/943,921;

VEHICLE ACTIVE NETWORK TOPOLOGIES, Attorney Docket Number  
IA00011, filed August 31, 2001, having Serial Number 09/944,891; and

DATA PACKET FOR A VEHICLE ACTIVE NETWORK, Attorney Docket  
Number IA00012, filed August 31, 2001, having Serial Number 09/943,914.

## Background of the Invention

### 1. Field of the Invention

The invention relates generally to the field of communication systems for vehicles such as automobiles and trucks, and more particularly, to communicatively coupling devices within the vehicle.

### 2. Description of the Related Art

Microprocessor technology has greatly improved the efficiency, reliability and safety of the automobile. Microprocessor devices have enabled airbags, anti-lock brakes, traction control, adaptive suspension and power train control just to name a few of the areas where processing technology has literally transformed the automobile. These systems, first provided by manufacturers only on the most expensive luxury and performance automobiles, are now common and even standard equipment on the most affordable economy models. Soon, control-by-wire applications will become equally commonplace. For example, throttle-by-wire has been successfully implemented on a number of vehicle platforms. Steer-by-wire and brake-by-wire applications are not far behind. Alternative fuel vehicles, including fuel cell vehicles, electric and hybrid vehicles will require still more sophisticated control applications, and hence still more processing capability.

The automobile is simultaneously being enhanced by information technology. Satellite navigation systems, voice and data communications, and vehicle telemetry systems inform the driver, entertain the passengers and monitor vehicle performance. These systems can provide driving directions, identify points of interest along the driver's route, remotely diagnose and/or predict vehicle problems, unlock the doors, disable the vehicle if stolen or summon emergency personnel in the event of an accident.

The growing amount and level of sophistication of vehicle oriented information technology presents the challenge to the automotive engineer to implement and integrate these technologies with existing and emerging vehicle systems in an efficient manner. Current design philosophy centers on the incorporation of one or more vehicle communication bus structures for interconnecting the various control elements, sensors, actuators and the like within the vehicle. The design of these bus structures is often driven by compliance with governmental regulations such as second-generation on-board diagnostics (OBD-II) and federal motor vehicle safety standards (FMVSS). These structures offer limited ability to adapt new technology to the vehicle. Moreover, given the typical four-year design cycle and ten-year life cycle of an automobile, the technology within a vehicle may become significantly obsolete even before the vehicle is brought to market, and

the bus architecture leaves the owner little ability to adapt new technology to the vehicle. Notwithstanding these limitations, the bus architecture offers a generally reliable, relatively fast platform for linking electronic devices and systems within the vehicle.

To link vehicle system technologies with vehicle information technologies, there has  
5 been proposed to incorporate a network architecture within the vehicle. For example,  
published Patent Cooperation Treaty (PCT) application number WO 00/77620 A2 describes  
an architecture based on the Ethernet wherein devices within the vehicle are coupled to the  
network. This publication describes a network including a cable backbone to which the  
devices are coupled and a network utility for controlling communications between the  
10 devices over the network. Important to note is that the proposed network does not integrate  
the vehicle systems, but instead is adapted to provide a platform for adding information  
technologies, such as pagers, personal digital assistants, navigations, etc. technologies to the  
vehicle. The power train, suspension, braking and airbag systems, as examples, utilize a  
vehicle bus for data communications, and these systems operate autonomously of the  
15 network described in the publication. A bridge or gateway is provide to couple the vehicle  
bus to the network as a device or client allowing data sharing between the bus and the  
network, but the data communication needs of the vehicle systems are not serviced by the  
network. A reason that these systems are designed to operate autonomously of the described  
network is that they have time critical, system critical data requirements that cannot be met  
20 by the network structure described. Additionally, the network described in the publication  
suffers from numerous single points of failure, such as if the cable backbone is disrupted or  
the network utility fails.

Thus there is a need for an architecture for automotive electronic systems that  
facilitates the efficient, reliable integration of in-vehicle electronic technologies and plug-  
25 and-play upgradeability.

### **Brief Description of the Drawings**

The invention is described in terms of the several preferred embodiments set out fully  
below and with reference to the following drawings in which like reference numerals are  
30 used to refer to like elements through out.

FIG. 1 is a block diagram illustration of an embodiment of a vehicle active network  
according to the invention.

FIG. 2 is a block diagram illustration of the vehicle active network shown in FIG. 1  
illustrating multiple communication path capability of the vehicle active network.

FIG. 3 is a block diagram illustration of an alternate embodiment of a vehicle active network.

FIG. 4 is a graphic illustration of an embodiment of the vehicle active network according to the invention.

5 FIG. 5 is a graphic illustration of a portion of the vehicle active network illustrated in FIG. 4 illustrating propagation of timing information throughout the network.

FIG. 6 is a graphic illustration of an alternate embodiment of a three-dimensional vehicle active network.

10 FIG. 7 is a graphic illustration of an alternate embodiment of a vehicle active network according to the invention incorporating a No-Go zone.

FIG. 8 is a graphic illustration of an embodiment of a vehicle active network according to the invention providing packet redundancy.

FIG. 9 is a schematic illustration of an embodiment of an active network element according to the invention.

15 FIG. 10 is a schematic illustration of an embodiment of a vehicle active network including a device forming a portion of the vehicle active network.

FIG. 11 is a schematic illustration of an alternate embodiment of a vehicle active network including a device forming a portion of the vehicle active element.

20 FIG. 12 is a schematic illustration of an alternate embodiment of a vehicle active network including a device forming a portion of the vehicle active element.

FIG. 13 is a schematic illustration of an alternate embodiment of a vehicle active network including a device forming a portion of the vehicle active element.

FIG. 14 is a block diagram illustration of linked active networks according to an alternate embodiment of the invention.

25 FIG. 15 is a block diagram illustration of linked active networks according to an alternate embodiment of the invention.

FIG. 16 is a graphic illustration of an alternate embodiment of a vehicle active network according to the invention incorporating a core portion.

30 FIG. 17 is a graphic illustration of an alternate embodiment of a vehicle active network illustrating adaptable scalability.

FIG. 18 is a graphic illustration of an alternate embodiment of a vehicle active network illustrating adaptable scalability.

FIG. 19 is a block diagram illustration of a topology for a vehicle active network according to a preferred embodiment of the invention.

FIG. 20 is a block diagram illustration of a topology for a vehicle active network according to an alternate preferred embodiment of the invention.

FIG. 21 illustrates various data packets that may be adapted for use with a vehicle active network according to the preferred embodiments of the invention.

5

### Detailed Description of the Preferred Embodiments

An architecture for automotive functional systems according to the invention is based upon inter-networking and computing principles. The architecture incorporates a vehicle active network for communicatively coupling devices within the vehicle. Device operation  
10 is independent of the interface of the device with the active network. Additionally, the architecture of the active network provides one or more levels of communication redundancy. The architecture provides for the total integration of vehicle systems and functions, and permits plug-and-play device integration, scalability and upgradeability.

The active network may include a plurality of communicatively coupled active  
15 elements, which permit communication between devices coupled to the active network without a network utility or arbiter. The active elements enable multiple simultaneous communication paths between devices within the vehicle. The multiple simultaneous communication paths may include a variety of potential paths among the active elements, including, for example, alternative paths responsive to network status, redundant paths or  
20 even a loop having a loop data rate different from a path data rate of other communication paths.

The active network may be based upon packet data principles and implement any suitable packet data transmission protocol. Suitable packet data protocols include, but are not limited to, transmission control protocol/Internet protocol (TCP/IP), asynchronous  
25 transfer mode (ATM), Infiniband, and RapidIO. Each of these protocols, when implemented in an active network according to the various embodiments of the invention, permits one or more levels of redundant communication capability to ensure reliable data transfer while permitting active system diagnostics and fault tolerance.

The active network may incorporate a fabric of active network elements  
30 communicatively coupling the devices. The fabric permits multiple simultaneous peer-to-peer communications. The active network elements may be arranged in, for example, an array topology, a multi-drop topology, or an asymmetric topology. Furthermore, the architecture may incorporate one or more levels of wireless communication. For example, the architecture supports peer-to-peer, one-to-many broadcast, many-to-many broadcast,

intra-network and inter-network communications, device to network, vehicle-to-vehicle and vehicle to remote station wireless communications.

Many additional advantages and features of the invention will be apparent from the description of the various preferred embodiments. At the outset it is important to point out that the invention is described in terms of embodiments implemented within a vehicle, or more particularly, an automobile. The terms vehicle and automobile as used herein may include automobiles, trucks, buses, trailers, boats, airplanes, trains and the like. Therefore, references to vehicle or automobile apply equally to virtually any type of commercially available vehicle.

FIG. 1 illustrates a vehicle 10 including an active network 12 to which various vehicle devices 14-20 are coupled via respective interfaces 22-28. The devices may be sensors, actuators and processors used in connection with various vehicle functional systems and sub-systems, such as, but not limited to, control-by-wire applications for throttle, braking and steering control, adaptive suspension, power accessory control, communications, entertainment, and the like.

The interfaces 22-28 are any suitable interface for coupling the particular device to the active network 12, and may be wire, optical, wireless or combinations thereof. The interfaced device is particularly adapted to provide one or more functions associated with the vehicle. These devices may be data producing, such as a sensor, data consuming, such as an actuator, or processing, which both produces and consumes data. Of course, an actuator, typically a data-consuming device, may also produce data, for example where the actuator produces data indicating it has achieved the instructed state, or a sensor may consume data, for example, where it is provided instructions for the manner of function. Data produced by or provided to a device, and carried by the active network 12, is independent of the function of the device itself. That is, the interfaces 22-28 provide device independent data exchange between the coupled device and the active network 12.

The active network 12 defines a plurality of communication paths 30 between the devices. The communication paths 30 permit multiple simultaneous peer-to-peer, one-to-many, many-to-many, etc. communications between the devices 14-20. Illustrated in FIG. 1, a communication path 32, illustrated by the bold arrowed lines, may be formed between device 14 and device 20. This is not the only communication path available for communications between devices 14 and 20. Illustrated in FIG. 2, a path 34 may also couple devices 14 and 20. During operation of the vehicle 10, data exchanged between devices 14 and 20 may utilize paths 32 and 34 or other paths between the devices. In operation, a single

path may carry all of a single data communication between the device 14 and the device 20, or several communication paths may carry portions of the data communication. Subsequent communications may use the same path or other paths as dictated by the then state of the active network 12. This provides reliability and speed advantages over bus architectures that provide single communication paths between devices, and hence are subject to failure with failure of the single path. Moreover, communications between other of the devices 14-20 may occur simultaneously using the communication paths 30.

The active network 12 may comply with transmission control protocol/Internet (TCP/IP), asynchronous transfer mode (ATM), Infiniband, RapidIO, or other packet data protocols. As such, the active network 12 utilizes data packets, having fixed or variable length, defined by the applicable protocol. For example, if the active network 12 uses asynchronous transfer mode (ATM) communication protocol, ATM standard data cells are used.

The devices 14-20 need not be discrete devices. Instead, the devices may be systems or subsystems of the vehicle and may include one or more legacy communication media, i.e., legacy bus architectures such as CAN, LIN, FLEXRAY or similar bus structures. In such embodiments, the respective interface 22-28 may be configured as a proxy or gateway to permit communication between the active network 12 and the legacy device 14-20. Alternatively, and referring to FIG. 3, the device 18 of the vehicle 10 is communicatively coupled via an interface 35 to a bus architecture 33. The bus architecture 33 is then coupled via the interface 26 to the active network 12. The bus architecture may be a CAN, LIN, FLEXRAY or similar bus structure.

Referring to FIG. 4, an active network 36 in accordance with an alternate embodiment of the invention includes a fabric 38 of active network elements 40 communicatively coupling a plurality of devices 44-50 via respective interfaces 52-58. Connection media 42 interconnects the active network elements 40. The connection media 42 may be bounded media, such as wire or optical fiber, unbounded media, such as free optical or radio frequency, or combinations thereof. In addition, the term active network element is used broadly in connection with the definition of the fabric 38 to include any number of intelligent structures for communicating data packets within the active network 36 without an arbiter or other network controller and may include: switches, intelligent switches, routers, bridges, gateways and the like. Data is thus carried through the network 36 in data packet form guided by the active elements 40.



The cooperation of the active elements 40 and the connection media 42 define a plurality of communication paths between the devices 44-50 that are communicatively coupled to the active network 36. For example, a route 60 defines a communication path from device 44 to device 50. If there is a disruption 61 along the route 60 inhibiting communication of the data packets from the device 44 to the device 50, for example, if one or active elements are at capacity or have become disabled or there is a disruption in the connection media joining the active elements along the route 60, a new route, illustrated as route 62, can be used. Route 62 may be dynamically generated or previously defined as a possible communication path, to ensure the communication between the device 44 and the device 50.

In some applications, it may be necessary to provide synchronized activity, which requires timing information be available within the active network. FIG. 5 illustrates a portion 80 of an active network that includes a fabric 82 of active elements 84. Connection media 86 interconnects the active elements 84. Active element 88 is defined as a root node or a root element. A spanning tree algorithm may be used in association with the active network to define the plurality of communication paths available within the active network. The plurality of communication paths may be defined by the spanning tree algorithm during an initial configuration, or may be defined by a running of the spanning tree algorithm during each power on cycle or by other periodic running of the spanning tree algorithm. Timing may be propagated from the root node element 88 in the form of timing messages 90 from the root node, active element 88, to each of the active elements 84 via the plurality of communication paths. From the root node, the spans of connecting media 86 between each active element 84, and hence any delay in clock cycles in such spans, is known, and therefore from the root node precise timing may be established at each of the active elements 84 and likewise at each of the devices coupled to the active network. Timing within the active network may be absolute, or may be differential.

Differential, or relative, timing is possible based on the configuration of the active network and the data packets. The point-to-point connections within the active network allow accurate calculation of time to traverse the network. Thus, one is able to know when a packet was generated based upon the point in the network it started at, the route it took, and when it arrived at the current point. The time the packet was generated is thus, "now" minus x units of time, where the x units of time is the known time based on the route. In this scenario for timing, a central or root node may not be required.

Timing information within the network may degrade, for example as the result of clock skew. Having the root node send periodic timing messages refreshes the timing information. Data packets communicated within the active network may also contain timing information allowing individual devices to update the timing information on an ongoing basis. Of course, the data packets may also contain timing information to indicate when certain activities are to take place, or to indicate the freshness of the information. Other methods for establishing timing within the active networks apart from the root node concept may be employed.

FIG. 6 illustrates an active network 100 including a fabric 102 of active network elements 104 arranged in a three-dimensional configuration. Connection media 106 communicatively couples the active network elements 104. The connection media may be wire, optical, radio frequency or combinations thereof. The three-dimensional configuration of fabric 102 may be used in connection with virtually any of the embodiments of an active network in accordance with the invention, and demonstrates the flexibility and scalability of such active networks.

FIG. 7 illustrates the active network 36 (FIG. 4) modified to include a No-Go zone 64. The No-Go zone 64 exclusively reserves a portion of the fabric 38, namely the active elements and connection media contained within the No-Go zone 64, for communication of data between device 46 and the device 48. The No-Go zone 64 may reserve a sufficient portion of the fabric 38 to provide a plurality of possible communication paths between the devices 46 and 48, or may reserve a single communication path. The No-Go zone 64 may be configured to carry data packets to/from the device 46 and to/from the device 48 to the exclusion of any other data packets. Alternatively, the No-Go zone 64 may be available for communication of data packets to/from any device provided that data packets to/from devices 46 and 48 have transmission priority. Still further, criteria may be established relating to the use of the No-Go zone 64 to transmit data to/from devices other than devices 46 and 48. For example, where a fault in the switch fabric requires use of the No-Go zone 64 or where the non-exclusive use of the No-Go zone 64 does not exceed a threshold percentage of the overall capacity of the No-Go zone.

The No-Go zone 64 provides assured communication capability between the devices associated with the No-Go zone 64. For example, if the devices 46 and 48 are associated with a steer-by-wire application, proper vehicle function requires that the data for this application be transmitted to the appropriate devices. Providing priority to the data packets associated with the steer-by-wire application and transmitting them within the switch fabric

38 generally may not sufficiently ensure the data packets are timely delivered. However, reserving a portion of the switch fabric 38, i.e., the No-Go zone 64, provides the advantages of a hard connection between the devices while preserving the flexibility of utilizing the entire switch fabric 38, if needed, should a fault occur within the No-Go zone 64. While described in connection with the active network 36 illustrated in FIG. 4, the concept of the No-Go zone may be applied to any of the active network architectures contemplated by the invention, including those shown in the embodiments illustrated in FIGs. 1 and 2.

Furthermore, while the No-Go zone 64 is shown as two-dimensional in FIG. 7, the No-Go zone 64 may correspond in dimension to that of the fabric of active network elements. Also, the No-Go zone 64 may be dynamically redefined during operation of the vehicle.

The multi-path architecture of the active network 12 and the active network 36 permits fault tolerance and fault diagnosis to be easily incorporated via data stream replication. Fault tolerance may be provided using replicated data packets sent along the same communication path or multiple data paths. An embodiment wherein data packets are replicated and transmitted along redundant paths is illustrated in FIG. 8, which again depicts the active network 36. Device 46 is communicatively coupled to the fabric 38 by interface 54. At switch element 66, data packets received from the device 44 are replicated, forming two streams of data packets (data streams). Of course more than two data streams may be generated, and additional data streams add additional levels of redundancy. The data streams are transmitted from the device 44 to the device 50 via different communication paths, and paths 68 and 70 are two of the numerous possible paths that may be formed in the switch fabric 38 from the device 46 to the device 50. Not all data packets need to travel on the same path, and the paths 68 and 70 merely illustrate the concept of the redundant paths. The redundancy provided by the two data streams (replicated data packets) enhances reliability because a failure or disruption of one of the streams does not completely interrupt transmission of the data between the devices. Moreover, by monitoring receipt of the data streams at the device 50 it is possible to determine whether a fault exists in the fabric 38, and to isolate the fault to a region of the fabric 38. That is, the fault will lie on one of the two paths 68 and 70 on which the transmission of the respective data stream failed. Additionally, performance of the fabric 38 may be measured based upon time of arrival data of the two data streams.

FIG. 9 illustrates an active element 110 that may be used in connection with the fabric 38. To illustrate the functionality and the adaptability of the active element 110, it is shown to include a plurality of input ports 112, output ports 114 and input/output ports 116

and 118. Various configurations of the active element 110 having more or fewer ports may be used in an active network depending on the application. The active element 110 may further include a processor 120 coupled with a memory 122. The processor 120 includes a suitable control program for effecting the operation of the active element 110 for coupling  
5 inputs to outputs in order to transmit data packets within fabric 38.

The simplex input ports 112 and output ports 114 may be adapted for optical media, while the duplex input/output ports 116 and 118 may be adapted for electrical media. Additionally, the active element 110 may include a radio frequency (RF) transceiver 124 for  
10 RF transmission of data packets to other switch elements within the switch fabric 38 and to switch elements of other active networks, for example active networks located in nearby vehicles. The switch element 110 may be an assembly of circuit components or may be formed as a single integrated circuit device.

FIG. 10 illustrates an alternate embodiment providing fault tolerance and fault detection. As illustrated in FIG. 8, a single interface 52 couples the device 44 to the fabric  
15 38. Failure of the interface 52 would result in the device 44 becoming uncoupled from the fabric 38. Referring then to FIG. 10, a portion 130 of a fabric, such as fabric 38, includes a plurality of active elements 132 communicatively coupled by connecting media 134. A device 136 is communicatively coupled to the portion 130. The device 136 includes an active element 138 integral to the device, and providing a plurality of input/output ports.  
20 The plurality of input/output ports, three of which are illustrated in FIG. 10, couple to interfaces 140, 142 and 144. The interfaces 140, 142 and 144 are communicatively coupled to switch elements 146, 148 and 150, respectively, of the portion 130. In this manner, the device 136 is communicatively coupled via a plurality of communication paths to the portion 130 of the fabric. Data streams may be communicated along each of the communication  
25 paths to a destination device. This adds reliability by providing redundant paths from the device 136 to the fabric. It is also possible to determine the existence and locations of faults and fabric performance by monitoring the receipt of the data streams at the destination device along each of the plurality of communication paths.

In FIG. 11, the device 136 of FIG. 10 has been replaced by a sub-system 152. The  
30 sub-system 152 includes a plurality of devices 154-158 that are coupled via interfaces 160-164, respectively, to an active element 166 within the device 136. The active element 166 is then coupled to the portion 130 of the fabric. The active element 166 may couple data streams from one or more of the devices 160-164 to the portion 130. Moreover, the data streams may be coupled on multiple communication paths 140-144 to the portion 130.

In FIG. 12, the device 170 includes redundant elements 172 and 174. That is, each of elements 172 and 174 are designed to provide the required function of the device 170. In addition to providing a vehicle-related function, the device 170 also includes device elements 176 and 178, i.e., active network elements integrated within the device 170 which also form a portion of the active network. The device elements 176 and 178 are coupled to active elements 146 and 148 of the portion 130. The device elements 172 and 174 are also coupled to each of the active elements 176 and 178 within the device 170 via connection media 184. Redundant function and redundant coupling of the device 170 to the fabric is provided by this arrangement ensuring that failure of either device elements 172 or 174 and/or failure of active elements 176 and 178 and/or active elements 146 and 148 will not cause a loss of the function of the device 170.

In FIG. 13, the system 180 includes devices 182, 184 and 186. Each of devices 182-186 may be designed to provide the same function, i.e., triple redundancy, or may provide separate functions. The system 180 also includes device elements 188-192. The device elements 188-192 are respectively coupled to active elements 146-150 of the portion 130. The device elements 188-192 are also coupled to each other by connection media 183-187. Thus, triply redundant function and coupling is provided.

FIG. 14 illustrates wireless coupling of active networks across vehicles. A first vehicle 200 includes an active network 202 including a plurality of active elements, two of which are indicated as 204 and 206. All of the active elements, including the elements 204 and 206, are communicatively coupled via media 208. A second vehicle 210 includes an active network 212 including a plurality of active elements, two of which is indicated as 214 and 216. All of these active elements, including the active elements 214 and 216, are communicatively coupled via media 218. Each of the active elements 204 and 206 includes wireless communication capability, and similarly, each of the active elements 214 and 216 includes wireless communication capability. For example, the active elements 204, 206 and 214, 216 may incorporate a radio frequency transceiver permitting these devices to communicate via radio frequency transmissions.

As shown in FIG. 13, the active element 204 is communicatively coupled with the active element 214 via radio frequency transmissions 220, and the active element 206 is communicatively coupled with the active element 216 via radio frequency transmissions 222. In this manner, multiple vehicles may be linked via the active elements disposed within the active networks. Linking the active networks in this manner effectively expands the active networks of both vehicles, and hence the number of communication paths available to

link devices in any of the linked vehicles. An automobile may be communicatively coupled to a trailer that it is towing. Two vehicles traveling together can be linked in order to exchange messages, vehicle functional data, entertainment programming, etc. For example, passengers in linked vehicles may jointly play electronic games or watch video

5 programming. A vehicle disabled because of the failure of one or more devices may be rendered operable in tandem with a rescue vehicle to which it is linked by using the functioning devices in the rescue vehicle to provide the function to both. Similarly, if a device becomes isolated in a vehicle because of a failure of a portion of the active network, communication to the device may be reestablished using a linked surrogate vehicle to  
10 provide communication paths to the isolated device.

While all of the active elements forming an active network may include radio frequency transmission capability, for inter-vehicle linking of active networks, as opposed to intra-vehicle linking of active elements, linking may be limited to selected ones of the active elements. These selected active elements may include security, authentication, encryption,  
15 etc. capability. Thus, while an active element within the vehicle may wirelessly link to virtually any other active element within the active network, active networks may be limited to linking via particular active elements. Moreover, the types and quantities of data exchanged may be limited. For linked active networks with low security and lacking encryption, the link may be limited to transmission of non-identifying vehicle operating data.  
20 For example, in a one-to-many broadcast application, a vehicle's headlights may be modulated to signal on-coming traffic about a traffic event. In this case, the signaling vehicle's headlights are a first wireless interface, and a photo-diode or similar device on the receiving vehicle is a second wireless interface. Many vehicles may report the event in this or similar fashion, and many other vehicles may receive the reported information thus  
25 establishes a many-to-many multicast.

One of the many applications of linking of active networks is the ability to upgrade systems by upgrading software within vehicles without having the vehicle return to a repair facility. Vehicles may identify upgraded software via the linking of active networks and request a copy of the upgraded software be communicated to the active network. While this  
30 process may be made seamless and transparent to the vehicle operator, safeguards may be included permitting the vehicle operator to authorize any such sharing and implementation of such upgraded software. Navigation, entertainment, and other similar program data may be shared via the inter-vehicle linking of active networks.

FIG. 15 illustrates an alternate arrangement for wireless coupling of active networks across vehicles. A first vehicle 240 includes an active network 242 including a plurality of active elements. Coupled to the active network 242 is a wireless interface 244. A second vehicle 246 includes an active network 248 including a plurality of active elements. The second vehicle 246 also includes a wireless interface 250. Each wireless interface 244 and 250 includes a suitable transceiver, such as an optical or radio frequency transceiver, and each may also include processing capability and memory. The wireless interfaces 244 and 250 arbitrate the wireless linking of the active networks 242 and 248 providing required authentication, security and encryption.

10 Referring now to FIG. 16, the active network 36 (FIG. 4) is adapted to include a core network portion 260. The core network portion 260 includes a plurality of core active elements 262. The core active elements 262 are communicatively coupled only to other active elements, whether core active elements 262 or other, peripheral active elements 40 forming a peripheral portion of the active network 36. High-speed media 264 provides  
15 interconnections between core active elements 262. In this manner, data may be transferred through the core network portion 260 at a first, high data rate, and transferred to/from devices coupled to the active network 36 at a second, slower data rate. Alternatively, the interconnection of the core active elements may be made using multiple communication links providing enhanced communication capacity. Devices are coupled to the active  
20 network via the peripheral active elements.

FIG. 17 illustrates the active network 36 adapted to include "fat pipe" members 270 and 272. Fat pipe members 270 and 272 provide direct coupling of the active element 274 to the active element 276 and the active element 278 to the active element 280, respectively. The fat pipe members 270 and 272 may be, and generally are high speed data carrying  
25 members adapted for particular applications, and may be particularly adapted to provide scalability in an after-market arrangement, such as coupling a DVD player to a video display. In that regard, the original equipment active elements may be replaced with the active elements 274-280 capable of handling the higher data capacity of the fat pipe members 270 and 282. Alternatively, the fat pipe members 270 and 272 may provide  
30 scalability in original equipment applications. For example, the fabric 38 may be configured for a base level of vehicle options, while premium options are provided by adding the fat pipe members 270 and 272.

FIG. 18 illustrates the active network 36 adapted with additional active elements 290 and 292 and connection media 294-302 coupling the active elements 290 and 292 to the

active network 36. FIG. 18 illustrates the manner in which active networks in accordance with the invention may be expanded, by adding connection media and additional active elements to the fabric as needed. If necessary, existing active elements may be replaced with active elements having a sufficient number of ports to be able to add the connection media

5 294-302. Moreover, the connection media 294-302 may have a higher data capacity than the existing connection media 294-302. As will be further appreciated from the embodiments of the invention illustrated in FIGs. 17 and 18, the fabric including either the "fat pipe" members or the additional active elements does not need to have a uniform configuration, and may have an asymmetric configuration.

10 FIGs. 19 and 20 illustrate alternative active network configurations. In FIG. 19, an active network 310 includes a ring 312 of interconnected active network elements (not depicted). A plurality of devices 314-322 is communicatively coupled by interfaces 324-332, respectively to the ring 312 in a multi-drop arrangement. Additionally, devices 320 and 322 are coupled for peer-to-peer communications by communication link 344.

15 Communication link 334 may be formed of any suitable media, including wire, optical, radio frequency or combinations thereof. The device 320 therefore may communicate with the device 322 via the network 312 or directly via the peer communication link 334.

In FIG. 20, an active network 340 includes a backbone 342 of interconnected active elements to which a plurality of devices 344-352 is communicatively coupled by interfaces

20 354-362, respectively to the backbone in a multi-drop arrangement. Additionally, devices 348 and 352 are coupled for peer-to-peer communications by communication link 364. Communication link 364 may be formed of any suitable media, including wire, optical, radio frequency or combinations thereof. The device 348 therefore may communicate with the device 352 via the network 340 or directly via the peer communication link 364.

25 FIG. 21 illustrates several data packet configurations that may be used in connection with active networks according to the embodiments of the invention. As described, the active networks may be configured to operate in accordance with TCP/IP, ATM, RapidIO, Infiniband and other suitable communication protocols. These data packets include structure to conform to the standard required. A typical data packet, such as the data packet 400

30 includes a header portion 402, a payload portion 404 and a trailer portion 406. As described herein, the active network and the network elements forming the active network may contain processing capability. In that regard, a data packet 410 includes along with a header portion 412, payload portion 414 and trailer portion 416 an active portion 418. The active portion may cause the network element to take some specific action, for example providing alternate



routing of the data packet, reconfiguration of the data packet, reconfiguration of the network element, or other action, based upon the content of the active portion. The data packet 420 includes an active portion 428 integrated with the header portion 422 along with a payload portion 424 and a trailer portion 426. The data packet 430 includes a header portion 432, a payload portion 434 and a trailer portion 436. An active portion 438 is also provided, disposed between the payload portion 434 and the trailer portion 436. Alternatively, as shown by the data packet 440, an active portion 442 may be integrated with the trailer portion 444 along with a payload portion 446 and a header portion 448. The data packet 450 illustrates a first active portion 460 and a second active portion 458, wherein the first active portion 460 is integrated with the header portion 452 and the second active portion 458 is integrated with the trailer portion 456. The data packet 450 also includes a payload portion 454. Certainly numerous other arrangements of the data packets for use with the present invention may be envisioned.

The data, and particularly the data packets, sent within the active network may be encrypted. The encryption function may be provided by the interface of the device to the active network, e.g., interfaces 22-28 (FIG. 1) or by the active network element of the active network to which the device is coupled. Data may be encrypted to ensure that it is not altered as it is communicated within the active network, which may be important for the proper function of various safety systems of the vehicle or to ensure compliance with governmental regulation. A suitable public or private key encryption algorithm may be employed, and the data may be encrypted before being packetized or the individual data packets may be encrypted after packetization. Moreover, detecting errors in the data upon decrypting may provide an indication of an error or fault condition in the active network along the route utilized by data packet, which caused the corruption of the data packet.

The active portion of the data packet may represent a packet state. For example, the active portion may reflect a priority of the data packet based on aging time. That is, a packet initially generated may have a normal state, but for various reasons, is not promptly delivered. As the data packet ages as it is routed through the active network, the active portion can monitor time since the data packet was generated or time when the packet is required, and change the priority of the data packet accordingly. The packet state may also represent an error state, either of the data packet or of one or more elements of the active network. The active portion may also be used to messenger data unrelated to the payload within the network, track the communication path taken by the data packet through the network, provide configuration information (route, timing, etc.) to active elements of the

active network, provide functional data to one or more devices coupled to the active network or provide receipt acknowledgment.

The invention has been described in terms of several embodiments, including a number of features and functions. Not all features and functions are required for every  
5 embodiment of the invention, and in this manner the invention provides an adaptable, fault tolerant, active network architecture for vehicle applications. The features discussed herein are intended to be illustrative of those features that may be implemented; however, such features should not be considered exhaustive of all possible features that may be implemented in a system configured in accordance with the embodiments of the invention.

**CLAIMS**

We claim:

1. A vehicle comprising:  
5 an active network for communicating data between devices within the vehicle, a device disposed within the vehicle and having a vehicle related function, the device being coupled to the active network, and wherein the device includes a device network element forming a portion of the active network.
- 10 2. The vehicle of claim 1, wherein the device network element comprises a switch.
3. The vehicle of claim 1, wherein the device network element comprises a router.
4. The vehicle of claim 1, wherein the device network element comprises a bridge.  
15
5. The vehicle of claim 1, wherein the active network comprises a packet data network.
6. The vehicle of claim 1, wherein the device comprises a second device network  
20 element.
7. The vehicle of claim 6, wherein the device network element and the second device network element are communicatively coupled.
- 25 8. The vehicle of claim 6, wherein the device network element is coupled to a first portion of the active network and the second device network element is coupled to a second portion of the active network.
9. The vehicle of claim 1, wherein the device includes a first functional element and a  
30 second functional element, and wherein the first functional element and the second functional element are coupled to the device network element.
10. The vehicle of claim 9, wherein the device network element comprises a first device network element and a second device network element, the first functional element

being coupled to the first device network element and the second functional element being coupled to the second device network element.

5 11. The vehicle of claim 10, wherein the first device network element and the second device network element are communicatively coupled.

12. The vehicle of claim 1, wherein the active network comprises a plurality of active network elements coupled by connection media.

13. In a vehicle comprising an active network for communications within the vehicle, the active network comprising a plurality of active network elements coupled by communication media, a method of coupling a device to the active network comprising:

5 providing within the device an device network element and coupling the device network element to the active network.

14. The method of claim 13, wherein the step of coupling the device network element to the active network comprises coupling the device network element to one of the active network elements of the plurality of active network elements.

10

15. The method of claim 13, wherein the step of coupling the device network element to the active network comprises coupling the device network element to a first active element of the plurality of active network elements and to a second active element of the plurality of active network elements.

15

16. The method of claim 13, wherein the step of providing a device network element comprises providing a first device network element and a second device network element and wherein the step of coupling the device network element to the active network comprises coupling the first and second device network elements to the active network.

20

17. The method of claim 16, wherein the step of coupling the first and second device network elements to the active network comprises coupling the first device network element to a first active element of the active network and coupling the second device network element to a second active element of the active network.

25

18. The method of claim 16, wherein the step of coupling the first and second device network elements to the active network comprises coupling the first and second device network elements to a first active element of the active network and coupling the first and second device network elements to a second active element of the active network.

30

19. The method of claim 16, further comprising coupling the first and second device network elements together.

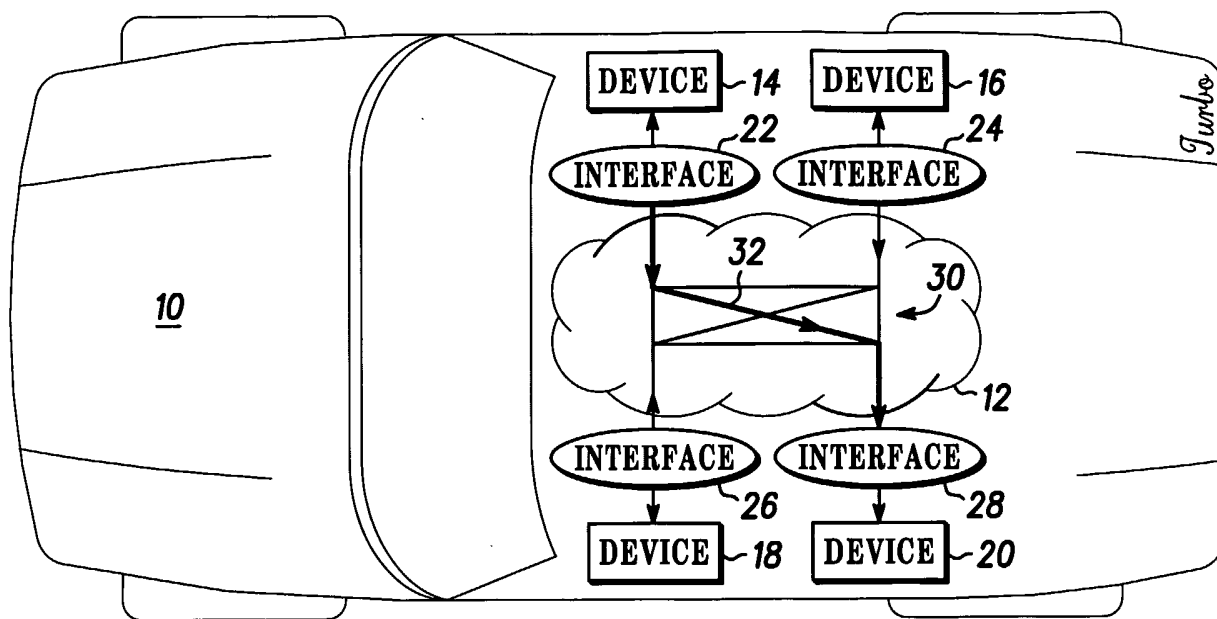

**FIG. 1**

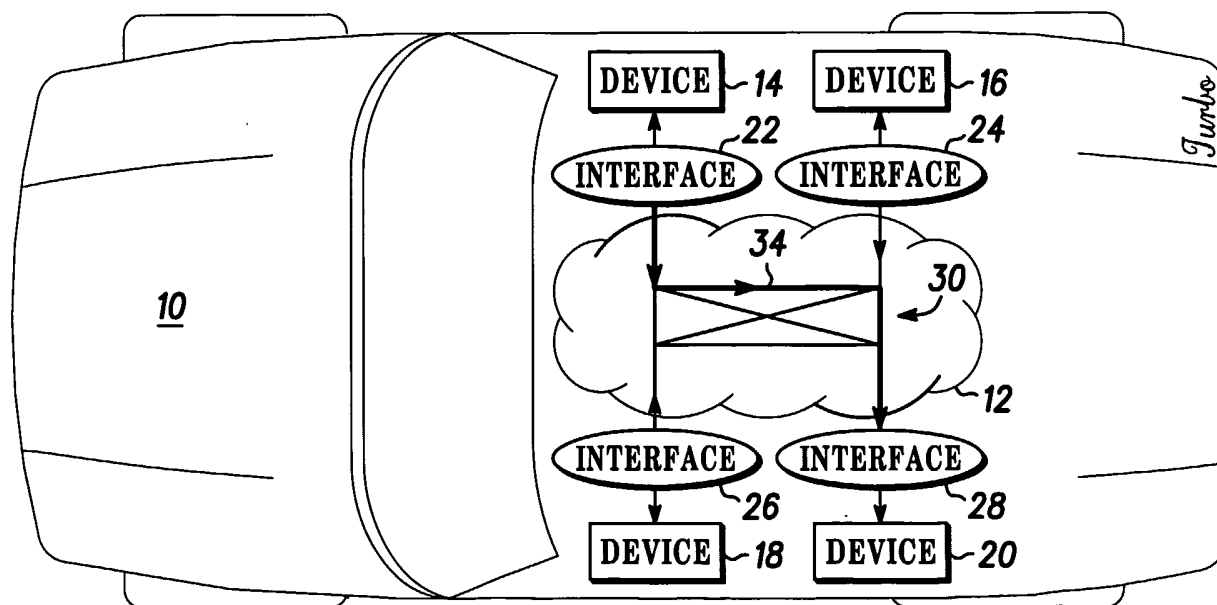

**FIG. 2**

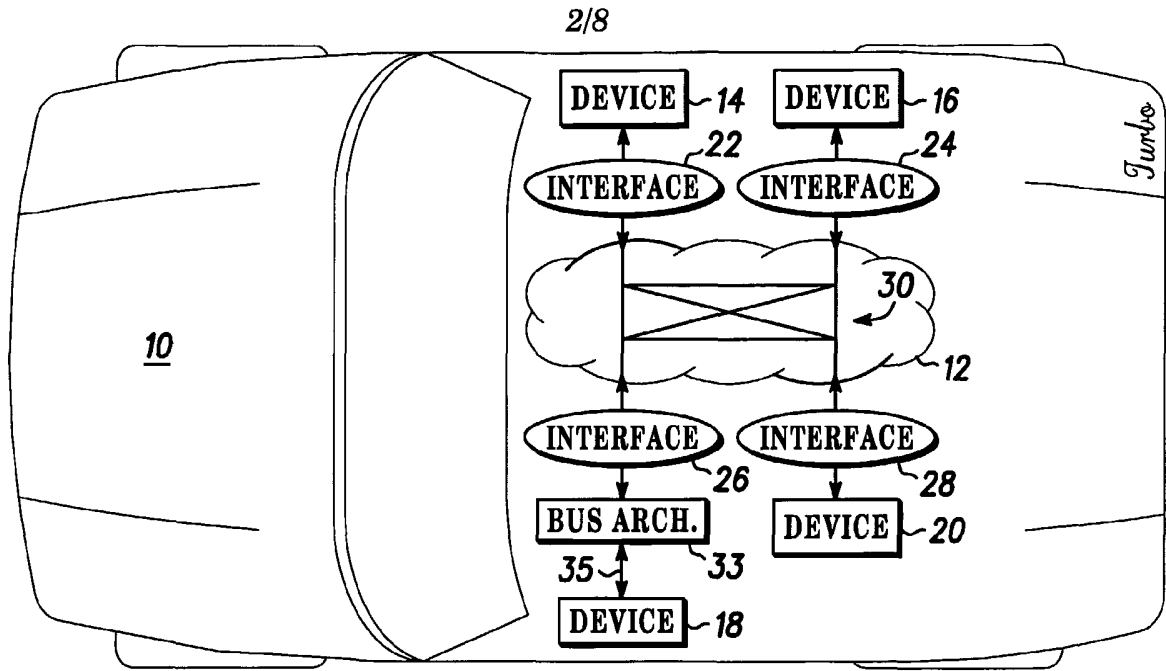

**FIG. 3**

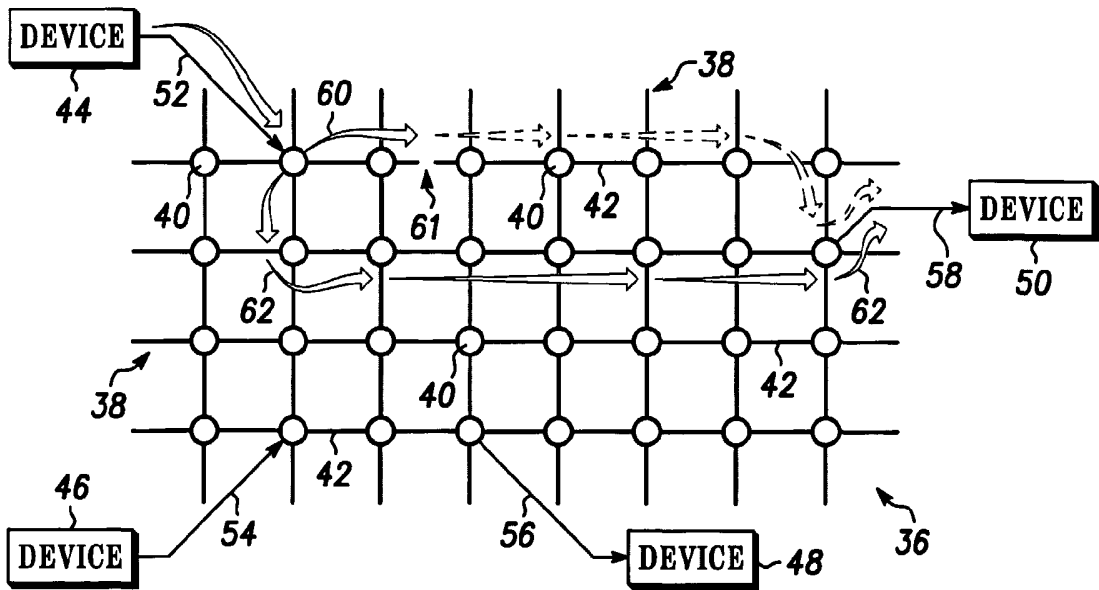

**FIG. 4**

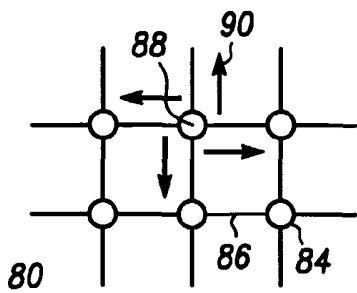

**FIG. 5**

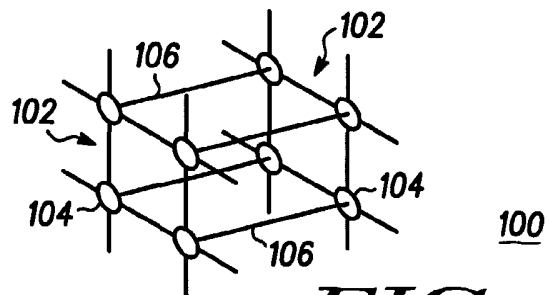

**FIG. 6**

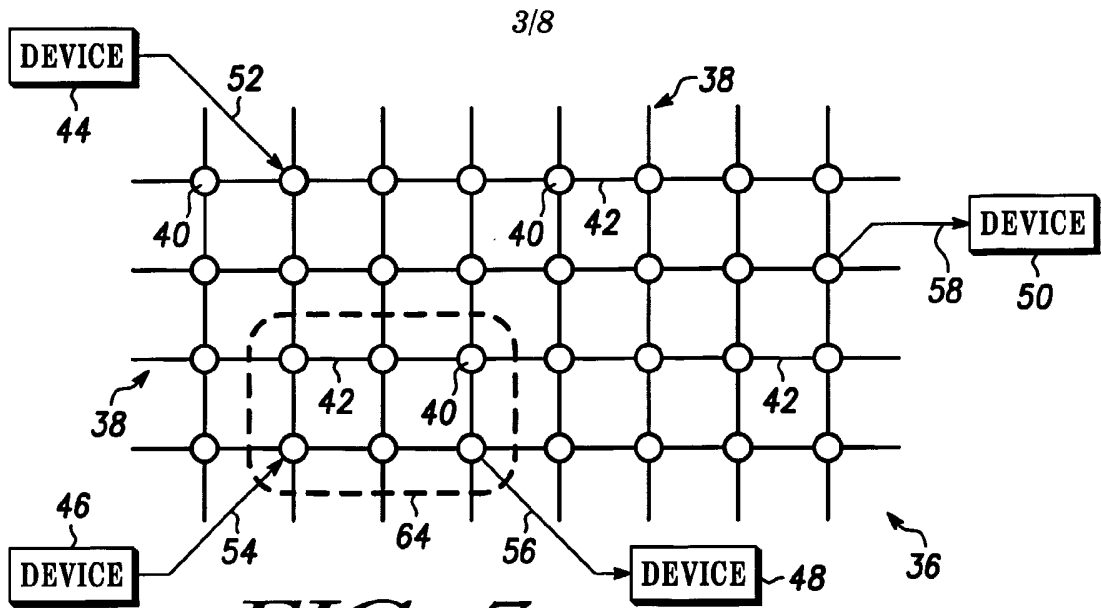

FIG. 7

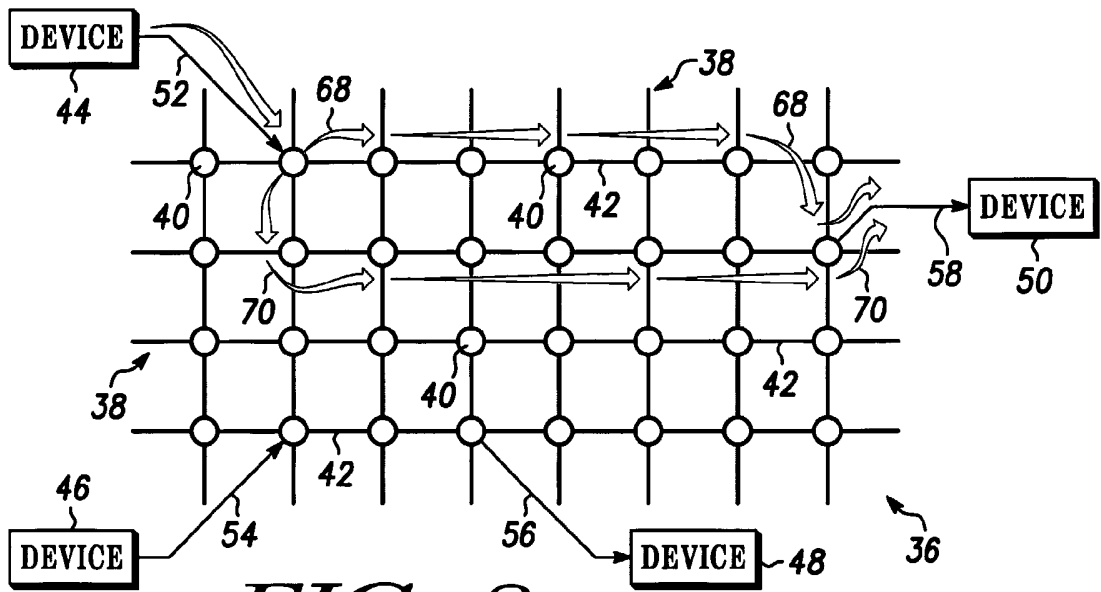

FIG. 8

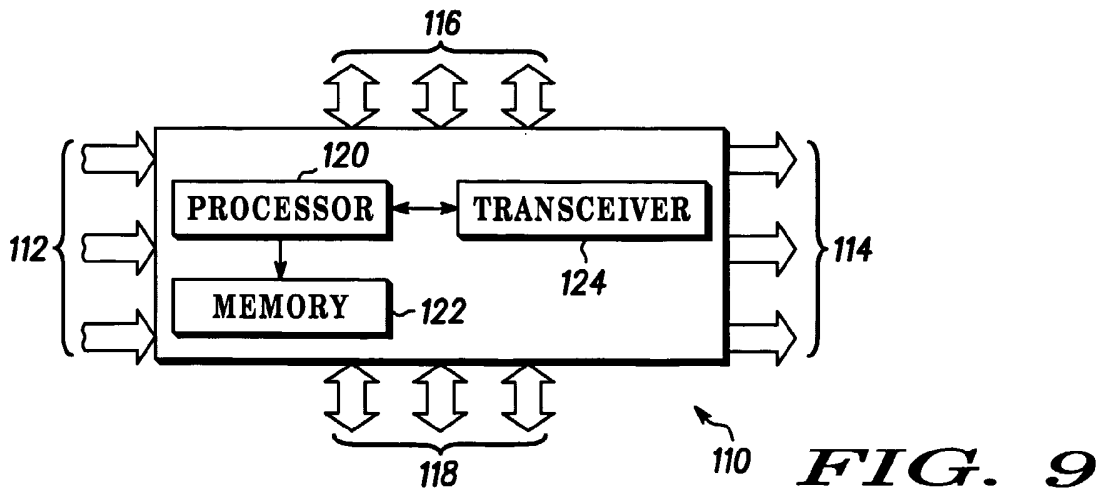
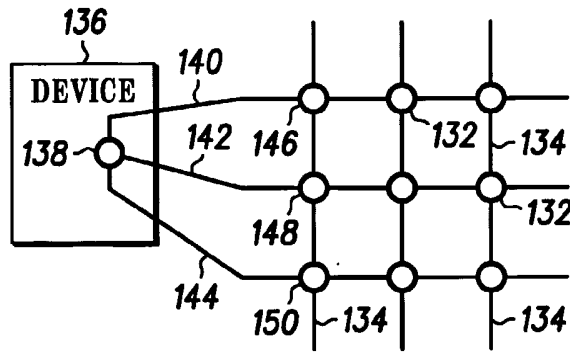

FIG. 9



4/8



130

FIG. 10

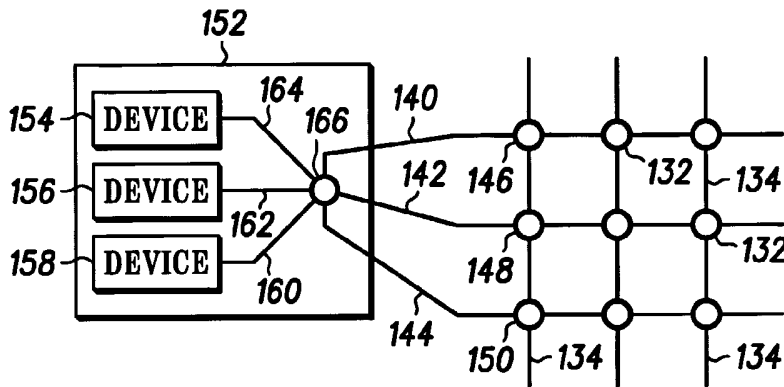

130

FIG. 11

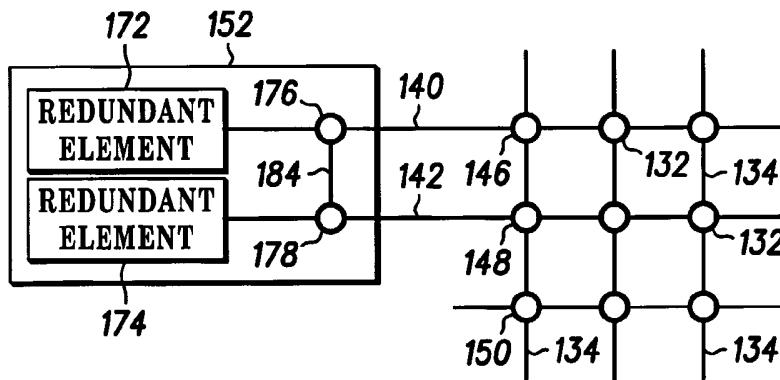

130

FIG. 12

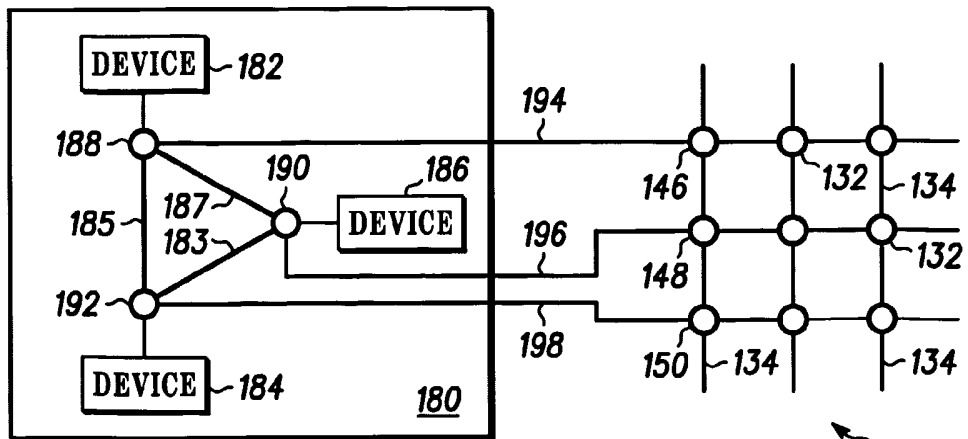

130

FIG. 13

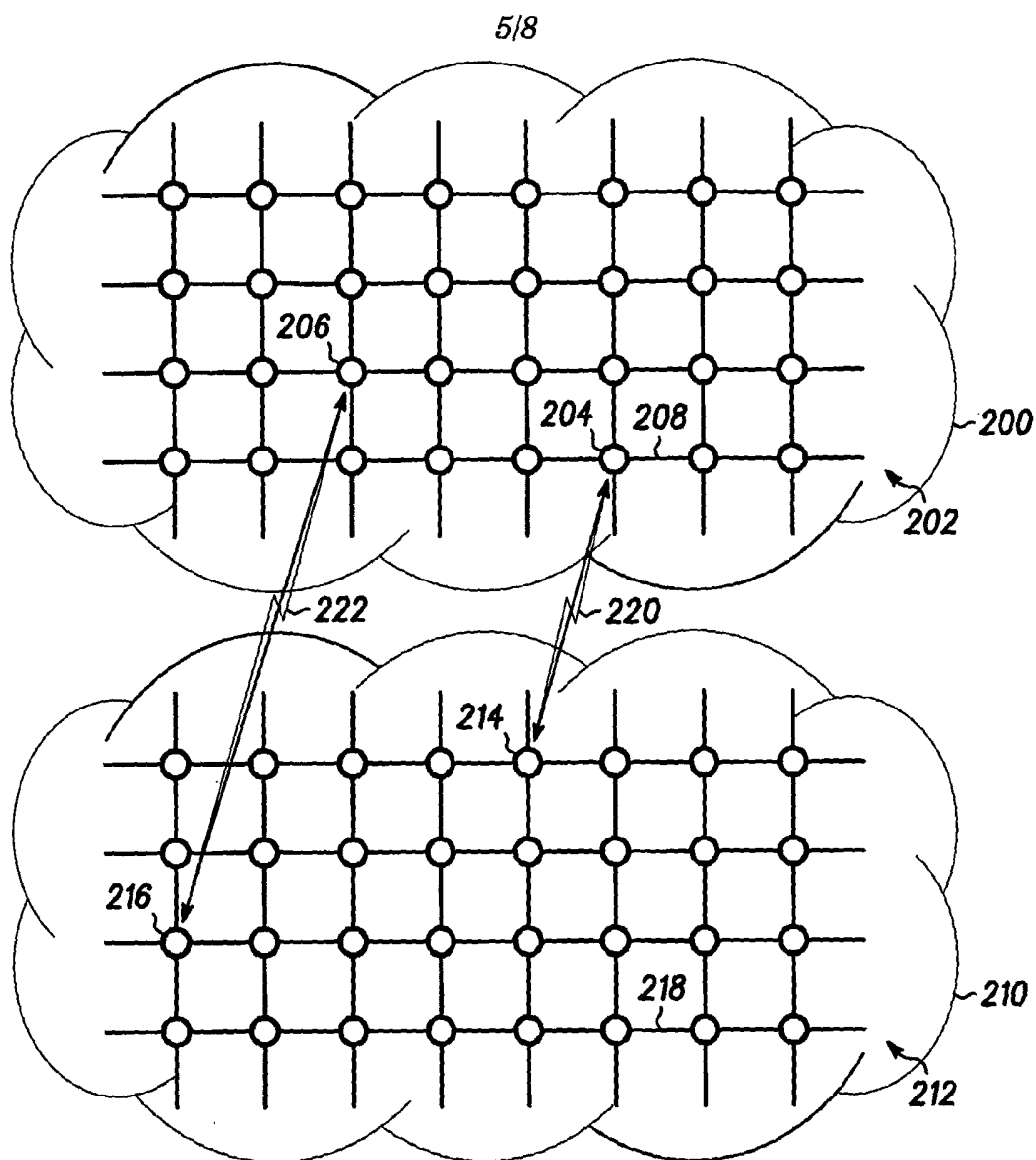

**FIG. 14**

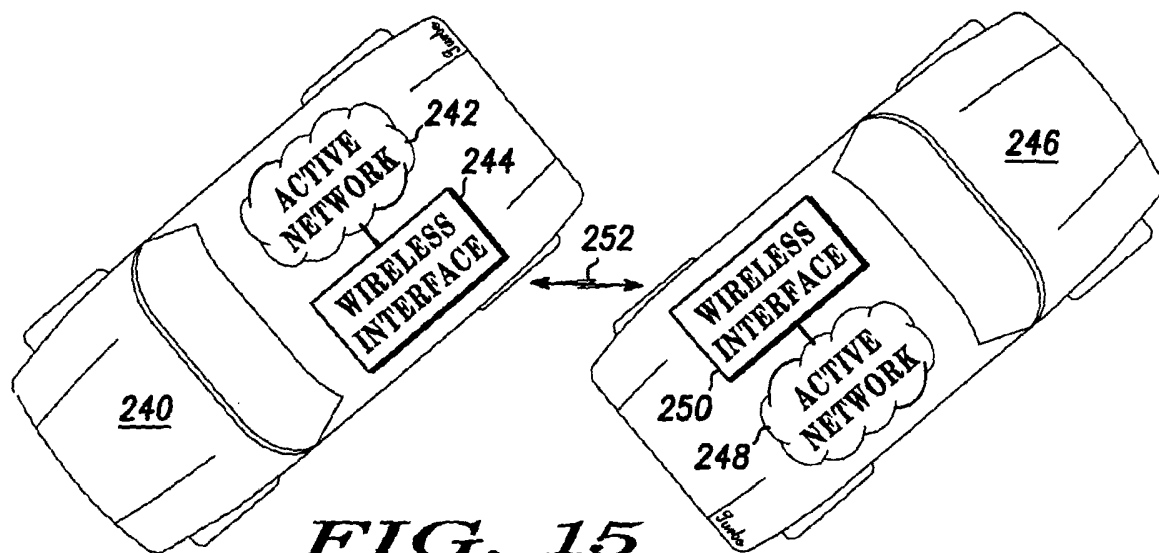

**FIG. 15**

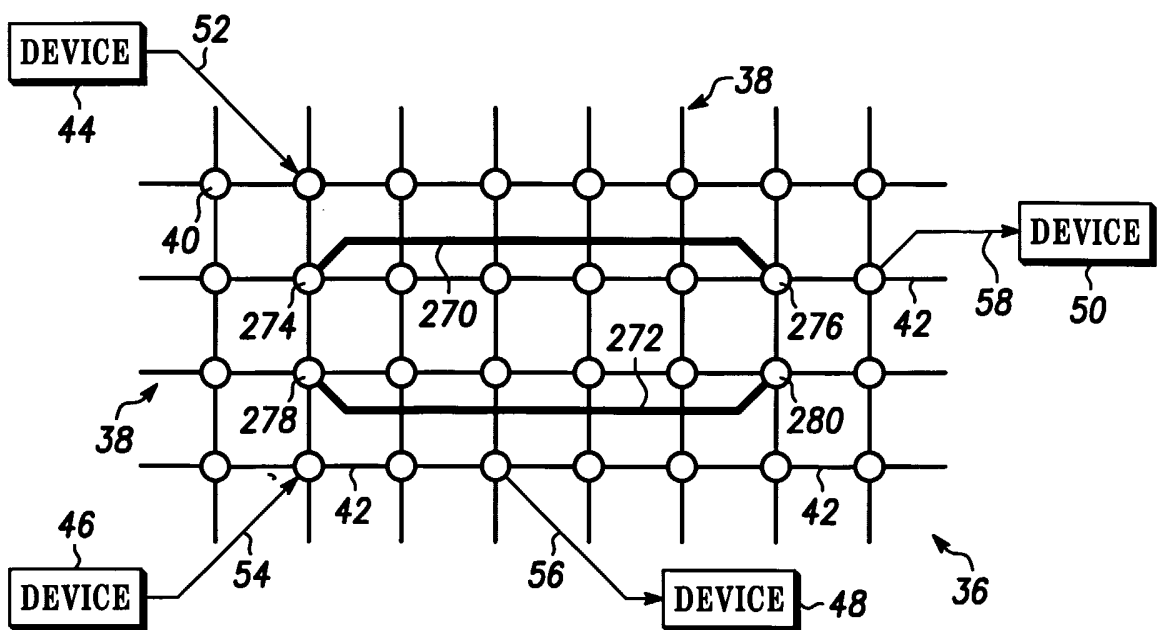
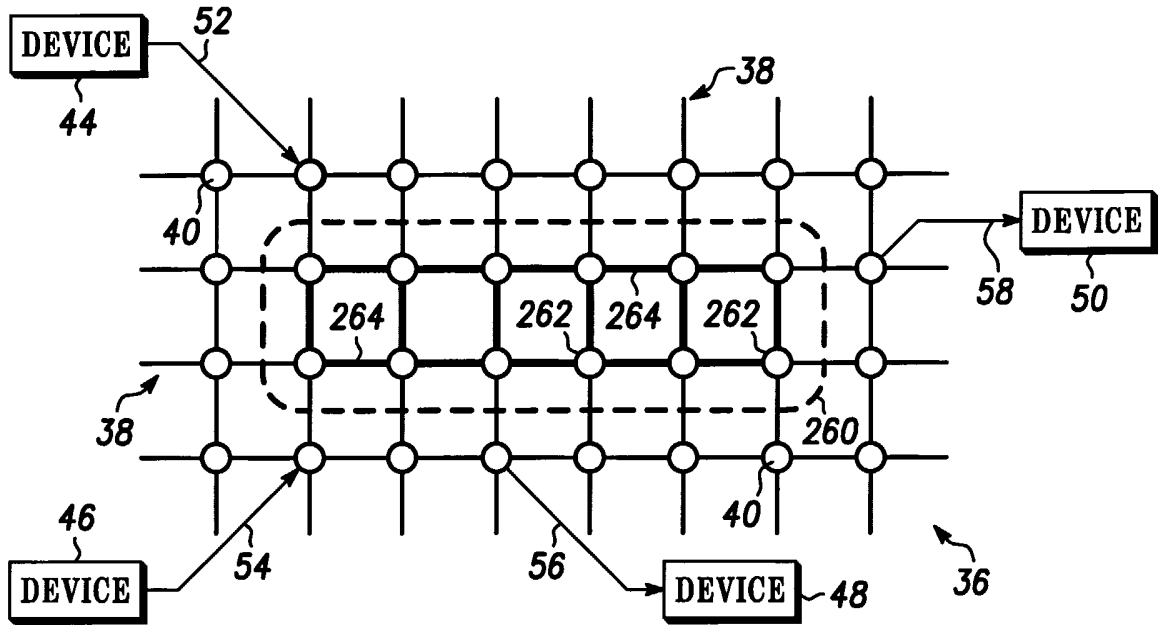

7/8

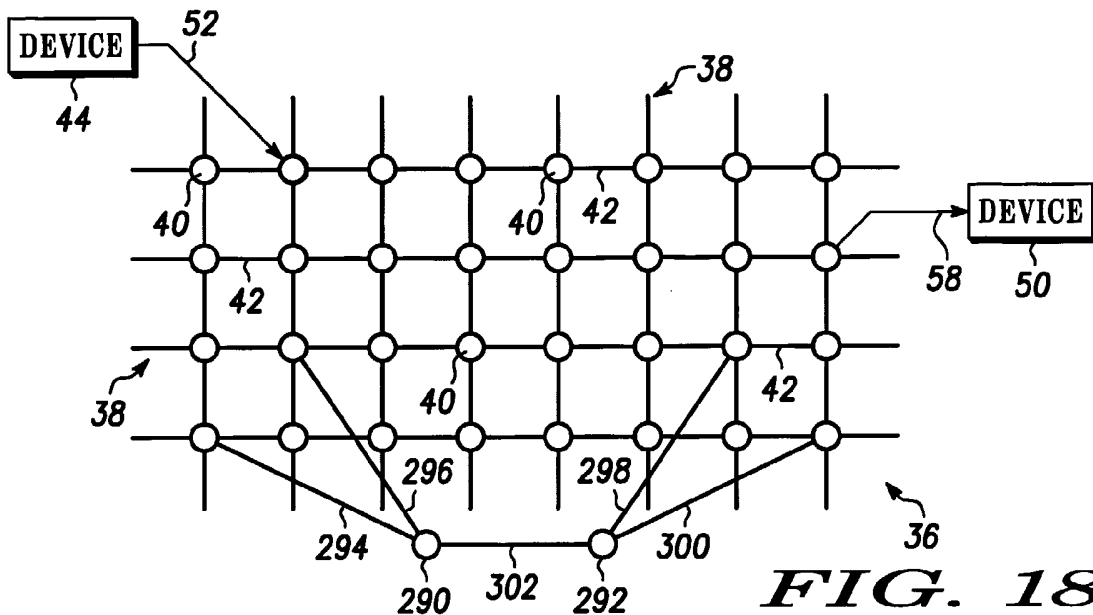

FIG. 18

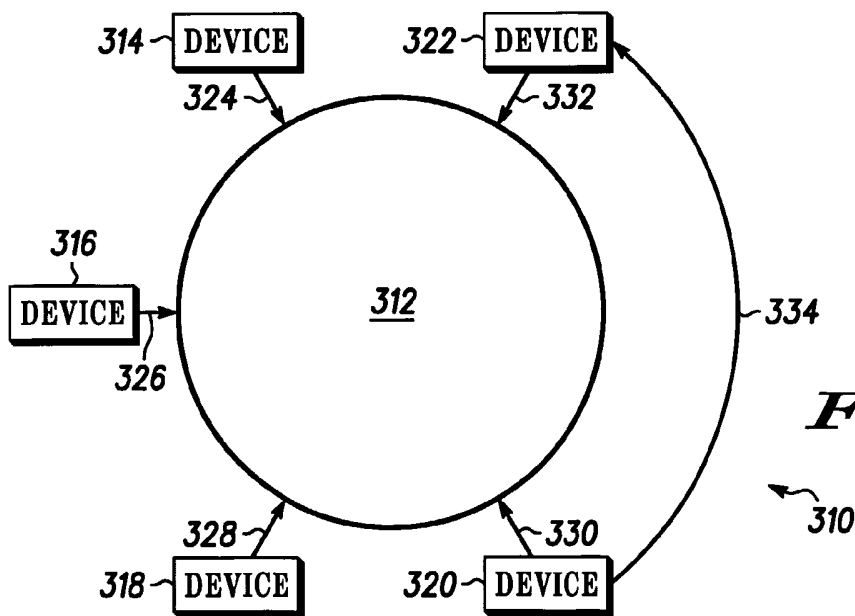

FIG. 19

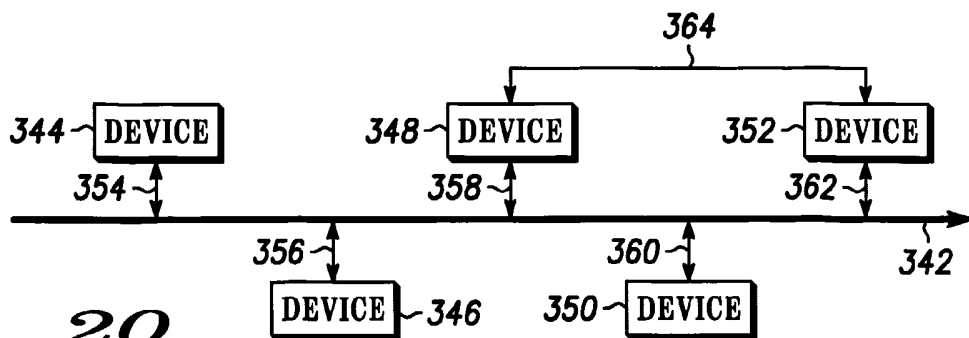
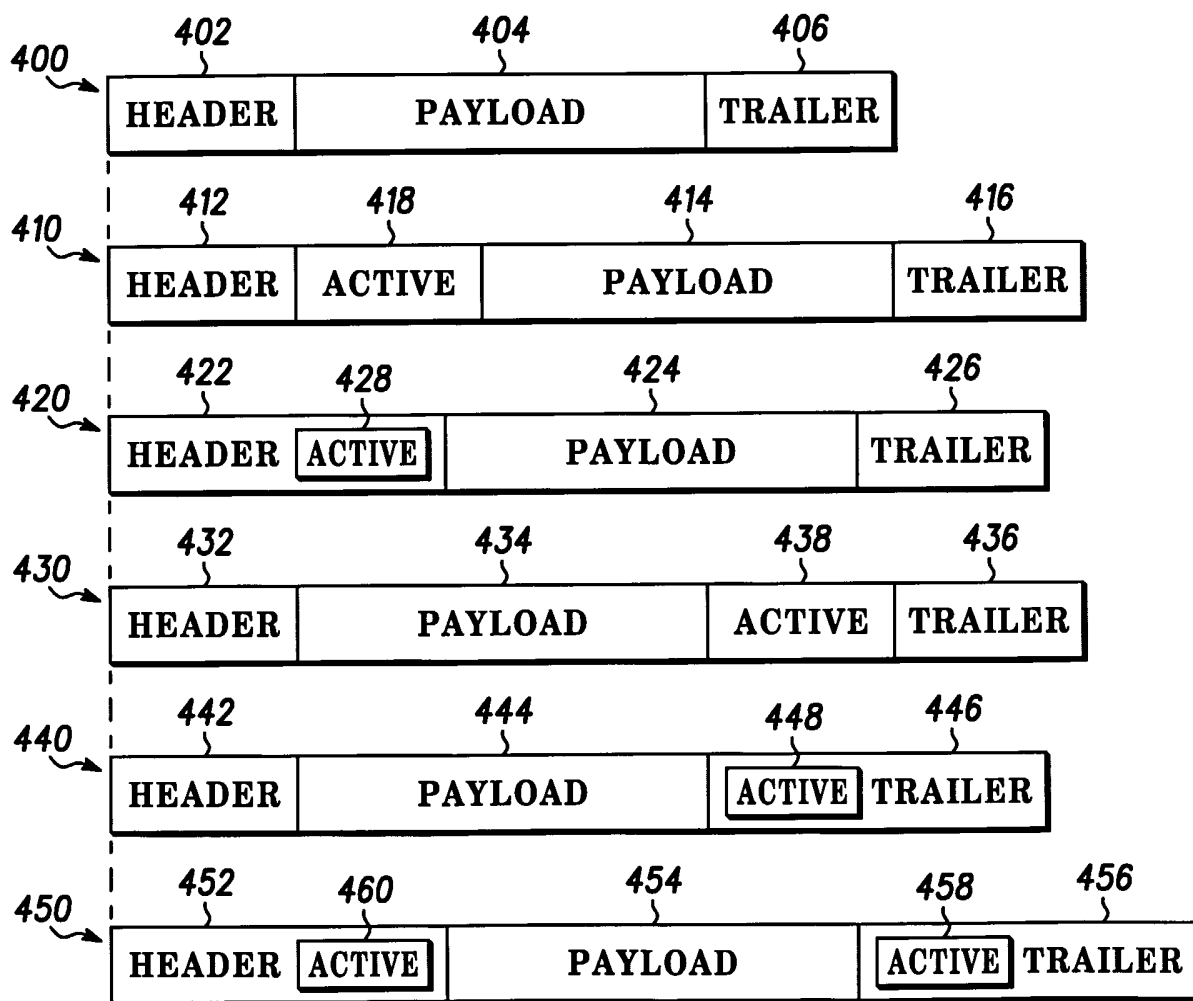

FIG. 20



**FIG. 21**

INTERNATIONAL SEARCH REPORT

Int. Patent Application No  
PCT/US 02/25865

A. CLASSIFICATION OF SUBJECT MATTER  
IPC 7 H04L12/56

According to International Patent Classification (IPC) or to both national classification and IPC

B. FIELDS SEARCHED

Minimum documentation searched (classification system followed by classification symbols)  
IPC 7 H04L

Documentation searched other than minimum documentation to the extent that such documents are included in the fields searched

Electronic data base consulted during the international search (name of data base and, where practical, search terms used)

EPO-Internal, PAJ, WPI Data, INSPEC

C. DOCUMENTS CONSIDERED TO BE RELEVANT

Category *	Citation of document, with indication, where appropriate, of the relevant passages	Relevant to claim No.
X	WO 00 77620 A (SUN MICROSYSTEMS INC) 21 December 2000 (2000-12-21) cited in the application	1-5, 12-14
Y	abstract page 3, line 20 -page 9, line 26 figure 2	6-11, 15-19
Y	KNIGHT S ET AL: "Virtual Router Redundancy Protocol" RFC 2338, April 1998 (1998-04), XP002135272 page 1, line 1 -page 9, line 1 -/--	6-11, 15-19

Further documents are listed in the continuation of box C.

Patent family members are listed in annex.

\* Special categories of cited documents :

- \*A\* document defining the general state of the art which is not considered to be of particular relevance
- \*E\* earlier document but published on or after the international filing date
- \*L\* document which may throw doubts on priority claim(s) or which is cited to establish the publication date of another citation or other special reason (as specified)
- \*O\* document referring to an oral disclosure, use, exhibition or other means
- \*P\* document published prior to the international filing date but later than the priority date claimed

- \*T\* later document published after the international filing date or priority date and not in conflict with the application but cited to understand the principle or theory underlying the invention
- \*X\* document of particular relevance; the claimed invention cannot be considered novel or cannot be considered to involve an inventive step when the document is taken alone
- \*Y\* document of particular relevance; the claimed invention cannot be considered to involve an inventive step when the document is combined with one or more other such documents, such combination being obvious to a person skilled in the art.
- \*&\* document member of the same patent family

Date of the actual completion of the international search

2 December 2002

Date of mailing of the international search report

27/12/2002

Name and mailing address of the ISA  
European Patent Office, P.B. 5818 Patentlaan 2  
NL - 2280 HV Rijswijk  
Tel. (+31-70) 340-2040, Tx. 31 651 epo nl,  
Fax: (+31-70) 340-3016

Authorized officer

Nocentini, I

## INTERNATIONAL SEARCH REPORT

Int. Application No  
PCT/US 02/25865

C.(Continuation) DOCUMENTS CONSIDERED TO BE RELEVANT		
Category *	Citation of document, with indication, where appropriate, of the relevant passages	Relevant to claim No.
A	<p>LEMAHIEU P ET AL: "Fault-tolerant switched local area networks" PARALLEL PROCESSING SYMPOSIUM, 1998. IPPS/SPDP 1998. PROCEEDINGS OF THE FIRST MERGED INTERNATIONAL... AND SYMPOSIUM ON PARALLEL AND DISTRIBUTED PROCESSING 1998 ORLANDO, FL, USA 30 MARCH-3 APRIL 1998, LOS ALAMITOS, CA, USA, IEEE COMPUT. SOC, US, 30 March 1998 (1998-03-30), pages 747-751, XP010276731 ISBN: 0-8186-8404-6 abstract</p> <p style="text-align: center;">---</p>	1-19
A	<p>WO 01 39435 A (IRONBRIDGE NETWORKS INC) 31 May 2001 (2001-05-31) abstract</p> <p style="text-align: center;">---</p>	1-19
A	<p>WO 01 19038 A (ERICSSON TELEFON AB L M) 15 March 2001 (2001-03-15) abstract</p> <p style="text-align: center;">---</p>	1-19
A	<p>US 6 134 589 A (HULTGREN ANDERS) 17 October 2000 (2000-10-17) abstract</p> <p style="text-align: center;">---</p>	1-19
A	<p>EP 0 884 873 A (AT &amp; T CORP) 16 December 1998 (1998-12-16) abstract</p> <p style="text-align: center;">---</p>	1-19
A	<p>EP 0 645 919 A (SIEMENS AG) 29 March 1995 (1995-03-29) abstract</p> <p style="text-align: center;">---</p>	1-19
A	<p>CORWIN LIGHT-WILLIAMS, JOSHUA DRAKE: "Linux PPP HOWTO" LINUX HOWTOS, 'Online! 19 October 2000 (2000-10-19), pages 83-84, XP002223075 Retrieved from the Internet: &lt;URL:http://www.ibiblio.org/pub/Linux/docs/HOWTO/other-formats/pdf/PPP-HOWTO.pdf&gt; 'retrieved on 2002-11-29! the whole document</p> <p style="text-align: center;">-----</p>	1-19

## INTERNATIONAL SEARCH REPORT

Information on patent family members

International Application No

PCT/US 02/25865

Patent document cited in search report		Publication date	Patent family member(s)	Publication date
WO 0077620	A	21-12-2000	US 2001051863 A1	13-12-2001
			US 6253122 B1	26-06-2001
			US 2001033225 A1	25-10-2001
			AU 5615800 A	02-01-2001
			EP 1188115 A2	20-03-2002
			WO 0077620 A2	21-12-2000
WO 0139435	A	31-05-2001	AU 1795001 A	04-06-2001
			WO 0139435 A2	31-05-2001
WO 0119038	A	15-03-2001	WO 0119038 A1	15-03-2001
			AU 1420500 A	10-04-2001
			DE 19983979 T0	01-08-2002
			GB 2371944 A	07-08-2002
US 6134589	A	17-10-2000	AU 8050398 A	04-01-1999
			WO 9858474 A1	23-12-1998
EP 0884873	A	16-12-1998	US 5996021 A	30-11-1999
			CA 2235029 A1	20-11-1998
			EP 0884873 A2	16-12-1998
			JP 10336249 A	18-12-1998
EP 0645919	A	29-03-1995	DE 4331579 A1	30-03-1995
			CA 2132068 A1	17-03-1995
			EP 0645919 A2	29-03-1995
			JP 7170277 A	04-07-1995
			US 5559959 A	24-09-1996