

(19) World Intellectual Property Organization
International Bureau



(43) International Publication Date
5 February 2009 (05.02.2009)

PCT

(10) International Publication Number
WO 2009/018201 A1

(51) International Patent Classification:
G01D 18/00 (2006.01)

(21) International Application Number:
PCT/US2008/071316

(22) International Filing Date: 28 July 2008 (28.07.2008)

(25) Filing Language: English

(26) Publication Language: English

(30) Priority Data:
60/952,313 27 July 2007 (27.07.2007) US

(71) Applicants and

(72) Inventors: **KHOURI, Louie** [US/US]; 964 Third Ave, 8th Floor, New York, NY 10022 (US). **BRYAN, Joseph, J.** [US/US]; 35 Maltese Dr., Fair Lawn, NJ 07410 (US).

(74) Agent: **SIMINSKI, Robert, M.**; Harness, Dickey & Pierce, PLC, 5445 Corporate Dr., Troy, MI 48098 (US).

(81) Designated States (unless otherwise indicated, for every kind of national protection available): AE, AG, AL, AM, AO, AT, AU, AZ, BA, BB, BG, BH, BR, BW, BY, BZ, CA, CH, CN, CO, CR, CU, CZ, DE, DK, DM, DO, DZ, EC, EE, EG, ES, FI, GB, GD, GE, GH, GM, GT, HN, HR, HU, ID, IL, IN, IS, JP, KE, KG, KM, KN, KP, KR, KZ, LA, LC, LK, LR, LS, LT, LU, LY, MA, MD, ME, MG, MK, MN, MW, MX, MY, MZ, NA, NG, NI, NO, NZ, OM, PG, PH, PL, PT, RO, RS, RU, SC, SD, SE, SG, SK, SL, SM, ST, SV, SY, TJ, TM, TN, TR, TT, TZ, UA, UG, US, UZ, VC, VN, ZA, ZM, ZW.

(84) Designated States (unless otherwise indicated, for every kind of regional protection available): ARIPO (BW, GH, GM, KE, LS, MW, MZ, NA, SD, SL, SZ, TZ, UG, ZM, ZW), Eurasian (AM, AZ, BY, KG, KZ, MD, RU, TJ, TM), European (AT, BE, BG, CH, CY, CZ, DE, DK, EE, ES, FI, FR, GB, GR, HR, HU, IE, IS, IT, LT, LU, LV, MC, MT, NL, NO, PL, PT, RO, SE, SI, SK, TR), OAPI (BF, BJ, CF, CG, CI, CM, GA, GN, GQ, GW, ML, MR, NE, SN, TD, TG).

Published:
— with international search report

(54) Title: DIGITAL X-RAY CALIBRATION SYSTEM

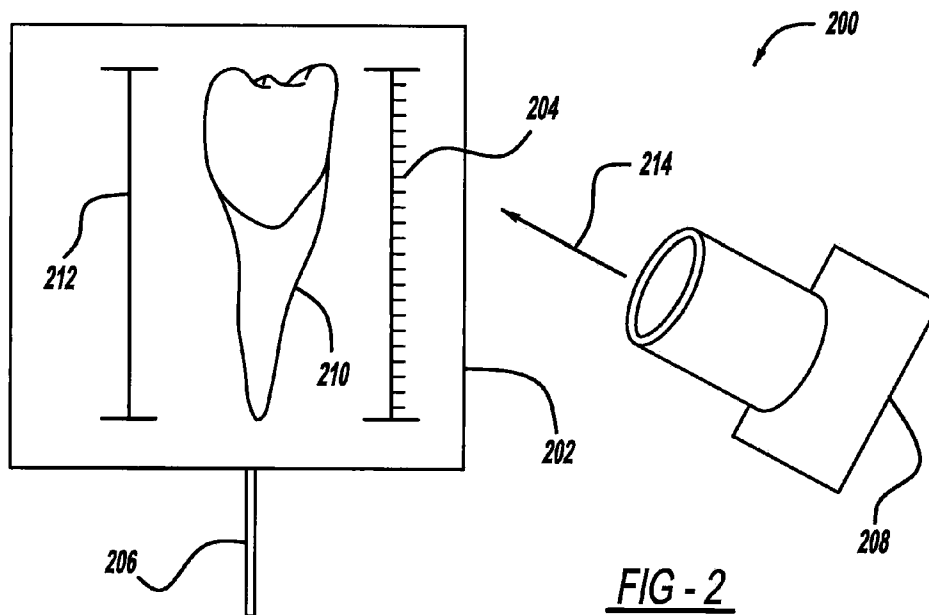

(57) Abstract: A calibration system of a digital radiography system comprises a measurement tool and a digital radiography module. The measurement tool of a predetermined length is disposed on an electronic sensor. The digital radiography module produces a digital radiographic image based on a signal from the electronic sensor, measures a measured length of the measurement tool within the image, and calibrates itself based on the predetermined and the measured lengths.

WO 2009/018201 A1

DIGITAL X-RAY CALIBRATION SYSTEM

CROSS-REFERENCE TO RELATED APPLICATIONS

[0001] This application claims the benefit of U.S. Provisional Application No. 60/952,313, filed on July 27, 2007. The disclosure of the above application is incorporated herein by reference in its entirety.

FIELD

[0002] The present disclosure relates to digital radiography and more particularly to a calibration system for digital radiography software.

BACKGROUND

[0003] The background description provided herein is for the purpose of generally presenting the context of the disclosure. Work of the presently named inventors, to the extent it is described in this background section, as well as aspects of the description that may not otherwise qualify as prior art at the time of filing, are neither expressly nor impliedly admitted as prior art against the present disclosure.

[0004] Digital radiography is a form of x-ray imaging where electronic sensors are used instead of photographic film. For example, the benefits of digital radiography include the ability to digitally transfer and enhance captured images and the ability to make electronic sensors thinner and more comfortable for dental radiography than photographic film. Feedback from digital radiography is instantaneous as opposed to film based x-rays, which require time and

expense for processing the film. Additionally, the amount of radiation required for digital radiography versus film based x-rays is reduced by up to about 90%. However, traditional digital radiography systems do not capture images as accurately as desired. While most dental imaging software has some form of measuring tool such as a drop and drag marker to “measure” desired points of a digital radiograph (x-ray), far too often the resulting measurement is inaccurate due to limitations in the proper placement of sensors within a patient’s arch due to the curvature of the arch of the teeth. As a result, it is virtually impossible to angle the digital x-ray sensor at exactly 90 degrees to the central ray of the x-ray source.

[0005] Referring now to FIG. 1A, a perspective view of an exemplary dental radiography system 100 that produces elongated digital radiographic images is shown. The dental radiography system 100 includes an electronic sensor 102, a video connector 104 that connects the electronic sensor 102 to dental radiography software (not shown), and an x-ray source 106. The electronic sensor 102 is placed near a tooth 108 of a length 110. When the x-ray source 106 projects an x-ray beam 112 onto the electronic sensor 102 and the tooth 108, the electronic sensor 102 captures a pattern of radiation that the tooth 108 reflects and outputs the pattern to the dental radiography software.

[0006] The software produces a digital radiographic image of the tooth 108 based on the pattern. However, since an angle 114 between the electronic sensor 102 and the x-ray beam 112 is greater than 90 degrees (e.g., due to operator error), the image is elongated. In other words, when a dental technician

and/or the software measure the length of the tooth 108 within the image, the measured length will be greater than the actual length 110.

[0007] Referring now to FIG. 1B, a perspective view of the exemplary dental radiography system 100 that produces foreshortened digital radiographic images is shown. Since an angle 116 between the electronic sensor 102 and the x-ray beam 112 is less than 90 degrees, the produced images are foreshortened. In other words, when the length of the tooth 108 is measured within one of the images, the measured length will be less than the length 110.

[0008] Accurate measurements of lengths within digital radiographic images are important for dental procedures and particularly those such as root canals and dental implant placement. Currently, the only means of establishing accurate measurements are by use of a dental instrument, known as a "file". Files of known length are inserted into an endodontically-treated tooth prior to taking an x-ray. Measurements are calibrated to the length of the file, typically while the file is in the tooth. While use of "files" theoretically offers an opportunity for accurate measurements of tooth structures, often the files employed are intentionally shorter than those that would offer the most accurate measurements for fear of mishaps when using such files. Even still, use of a file is limited to an endodontically-treated tooth, which only occurs in up to about 3% of all dental procedures. There are no practical systems for accurately measuring other areas of the oral cavity, such as bone structure, which is essential for properly placing dental implants. Dental professionals tend to be extremely cautious in placing implants, and more often than not, use implants that are smaller than

they should be due to a lack of confidence in the measurements obtained using digital radiography. Use of a smaller than appropriate implant can, over time, affect the stability of the implant and result in a plethora of undesirable consequences.

SUMMARY

[0009] A calibration system of a digital radiography system comprises a measurement tool and a digital radiography module. The measurement tool of a predetermined length is disposed on an electronic sensor. The digital radiography module produces a digital radiographic image based on a signal from the electronic sensor, measures a measured length of the measurement tool within the image, and calibrates itself based on the predetermined and the measured lengths.

[0010] A method of operating a calibration system of a digital radiography system comprises producing a digital radiographic image based on a signal from an electronic sensor; measuring a measured length of a measurement tool of the electronic sensor within the image; and calibrating a digital radiography module based on a predetermined length of the measurement tool and the measured length.

[0011] Further areas of applicability of the present disclosure will become apparent from the detailed description provided hereinafter. It should be understood that the detailed description and specific examples are intended for purposes of illustration only and are not intended to limit the scope of the disclosure.

BRIEF DESCRIPTION OF THE DRAWINGS

[0012] The present disclosure will become more fully understood from the detailed description and the accompanying drawings, wherein:

[0013] FIG. 1A is a side view of an exemplary dental radiography system that produces elongated digital radiographic images according to the principles of the prior art;

[0014] FIG. 1B is a perspective view of the dental radiography system that produces foreshortened digital radiographic images according to the principles of the prior art;

[0015] FIG. 2 is a perspective view of an exemplary dental radiography system that includes a calibration system for dental radiography software according to the principles of the present disclosure;

[0016] FIG. 3A is a perspective view of an exemplary electronic sensor according to the principles of the present disclosure;

[0017] FIG. 3B is a perspective view of another exemplary implementation of the electronic sensor according to the principles of the present disclosure;

[0018] FIG. 3C is a perspective view of another exemplary implementation of the electronic sensor according to the principles of the present disclosure;

[0019] FIG. 4A is a perspective view of another exemplary implementation of the electronic sensor and an exemplary cover according to the principles of the present disclosure;

[0020] FIG. 4B is a perspective view of another exemplary implementation of the electronic sensor and another exemplary implementation of the cover according to the principles of the present disclosure;

[0021] FIG. 4C is a perspective view of another exemplary implementation of the electronic sensor and another exemplary implementation of the cover according to the principles of the present disclosure;

[0022] FIG. 5A is a screenshot illustrating the dental radiography software displaying a digital radiographic image that is produced by the dental radiography system according to the principles of the present disclosure; and

[0023] FIG. 5B is a screenshot illustrating the dental radiography software being used to measure a length within the digital radiographic image according to the principles of the present disclosure.

DETAILED DESCRIPTION

[0024] The following description is merely exemplary in nature and is in no way intended to limit the disclosure, its application, or uses. For purposes of clarity, the same reference numbers will be used in the drawings to identify similar elements. As used herein, the phrase at least one of A, B, and C should be construed to mean a logical (A or B or C), using a non-exclusive logical or. It should be understood that steps within a method may be executed in different order without altering the principles of the present disclosure.

[0025] As used herein, the term module refers to an Application Specific Integrated Circuit (ASIC), an electronic circuit, a processor (shared, dedicated, or group) and memory that execute one or more software or firmware

programs, a combinational logic circuit, and/or other suitable components that provide the described functionality.

[0026] To accurately measure lengths within digital radiographic images, the digital radiography system of the present disclosure includes a calibration system for digital radiography software. The calibration system includes a marker (i.e., measurement tool) of known length that is embedded within or disposed on an electronic sensor. The calibration system further includes a read function for the software that measures a length of the marker within captured images and calibrates the software based on the measured length and the known length. While the operation of the calibration system will be discussed as it relates to a dental radiography system (e.g., for general dentistry, periodontics, endodontics, and oral surgery), the principles of the present disclosure are also applicable to any radiography system. For example only, radiography systems may include, but are not limited to, medical radiography systems, radiography systems for the automotive industry, and/or radiography systems for airport security.

[0027] Referring now to FIG. 2, a perspective view of an exemplary dental radiography system 200 that includes a calibration system for dental radiography software is shown. The dental radiography system 200 includes an electronic sensor 202 that includes a marker 204 of known length, a video connector 206 that connects the electronic sensor to the dental radiography software (not shown), and an x-ray source 208. For example only, the electronic sensor 202 may include, but is not limited to, a charge-coupled device (CCD)

image sensor and/or a complementary metal-oxide-semiconductor (CMOS) image sensor.

[0028] The marker 204 is integrated with the sensor whereby it is either embedded within or disposed on the electronic sensor 202 in various embodiments. For example only, the marker 204 may be disposed along the right edge of the electronic sensor 202. The marker 204 may include length markings. For example only, the video connector 206 may include, but is not limited to, an RCA connector, an Universal Serial Bus (USB) connector, and/or a High-Definition Multimedia Interface (HDMI) connector.

[0029] The electronic sensor 202 is placed near a tooth 210 of a length 212. When the x-ray source 208 projects an x-ray beam 214 onto the electronic sensor 202 and the tooth 210, the electronic sensor 202 captures a pattern of radiation that the tooth 210 reflects and outputs the pattern to the dental radiography software. The software produces a digital radiographic image of the tooth 210 based on the pattern. The image is elongated or foreshortened if the angle between the electronic sensor 202 and the x-ray beam 214 is not 90 degrees.

[0030] To accurately measure lengths within the captured image even if the image is elongated or foreshortened, the dental radiography software includes a read function that measures a length of the marker 204 within the image. The read function calibrates the software based on the measured length and the known length of the marker 204. For example only, the read function may determine a proportional correction factor based on the known length

divided by the measured length. When the software is being used to measure other lengths within the image, the software may multiply the other measured lengths by the proportional correction factor to correct the other measured lengths (i.e., provide accurate measurements).

[0031] The dental radiography system 200 may provide accurate measurements for all dental procedures. The dental procedures may include, but are not limited to, implant placements (e.g., measuring an implant's proximity to an inferior alveolar nerve and/or a sinus), root canal preparation and completion, periodontal evaluations (e.g., measuring periodontal pocket depth), measuring bone defects, and measuring depth of a filling and/or a cavity with respect to a nerve. In other words, the dental procedures are not limited to those involving endodontically-treated teeth.

[0032] Referring now to FIGs. 3A-3C, perspective views of other exemplary implementations of the electronic sensor 202 are shown. For example only, the electronic sensor 202 may include a marker 302 that is disposed along the left edge of the electronic sensor 202 as shown in FIG. 3A instead of the right edge as shown in FIG. 2. Alternatively, the electronic sensor 202 may include a marker 304 that is disposed along the top edge of the electronic sensor 202 as shown in FIG. 3B or along the bottom edge (not shown). In another embodiment, the electronic sensor 202 may include both of the markers 302 and 304 as shown in FIG. 3C. Accordingly, the electronic sensor 202 may include at least one marker that may be disposed along at least one

edge of the electronic sensor 202, so the electronic sensor 202 may be used in various positions.

[0033] Referring now to FIGs. 4A-4C, perspective views of another exemplary implementation of the electronic sensor 202 and exemplary implementations of a cover 402 are shown. For example only, the electronic sensor 202 may not include any markers. Instead, the cover 402 may include at least one integrated marker 404 typically occurring along an edge thereof. Alternatively, the cover 402 may include a marker 406 along the left edge as shown in FIG. 4A or right edge (not shown), the top edge of the cover 402 as shown in FIG. 4B or along the bottom edge (not shown).

[0034] In another embodiment, the cover 402 may include both of the markers 404 and 406 as shown in FIG. 4C. Accordingly, the cover 402 may include at least one marker that may be disposed along at least one edge of the cover 402. The cover 402 is retrofit to the electronic sensor 202, so the electronic sensor 202 may be used in various positions to calibrate the dental radiography software. The above described covers will be formed from a material that does not interfere with the x-ray function and may be formed from an autoclavable material or optionally may be disposable.

[0035] Referring now to FIG. 5A, a screenshot illustrating the dental radiography software displaying a digital radiographic image that is produced by the dental radiography system is shown. The image includes images of a marker 502, a tooth 504, and a root 506. The dental radiography software measures the length of the marker 502 and calibrates itself based on the measured length and

the known length of the marker 502. For example, if the image is elongated, the dental radiography software may determine the proportional correction factor to be greater than 1 and may multiply all future measurements within the image by the proportional correction factor.

[0036] Referring now to FIG. 5B, a screenshot illustrating the dental radiography software being used to measure a length within the digital radiographic image is shown. A user of the software places a mouse pointer (not shown) at a point 508 and clicks, marking the initial measuring point. The point 508 corresponds to the top of the tooth 504.

[0037] The user places the mouse pointer at a point 510 and clicks, marking the final measuring point and creating a dashed line 512 between the points 508 and 510. The point 510 corresponds to the apex of the root 506. The software determines a length 514 between the points 508 and 510 based on a measured length between the points 508 and 510 and a correction factor (e.g., the proportional correction factor). The software displays the length 514 to the user.

[0038] In an alternative embodiment, the dental radiography software includes a data file function (not shown) that provides one or more predetermined data points in which measured data points from a digital radiographic image may be compared to. The dental radiography software calibrates itself based on the predetermined data points and the measured data points. Accordingly, the dental radiography software may be used to accurately measure lengths within the captured image.

[0039] As should be appreciated from the above-described systems, a convenient way of obtaining accurate data from digital radiography images has now been accomplished. This more accurate data is especially useful to dental professionals in carrying out complex procedures such as root canals and implants. In addition to the various dental applicants described herein, the systems of the present invention are useful in numerous other professions that rely on accurate digital radiographic data.

[0040] As a non-limiting example, doctors would benefit from the ability to accurately measure the dimension and the proximity of cancerous tissue to vital organs/surrounding tissue. A Chiropractor can measure the amount of compression on a spinal disc, along with other critical measurements. A doctor will also benefit from the ability to accurately measure the length of a fracture, or the amount of lost length in long bones, which will help him to know where to reposition the bone(s).

[0041] Those skilled in the art can now appreciate from the foregoing description that the broad teachings of the disclosure can be implemented in a variety of forms. Therefore, while this disclosure includes particular examples, the true scope of the disclosure should not be so limited since other modifications will become apparent to the skilled practitioner upon a study of the drawings, the specification, and the following claims.

CLAIMS

What is claimed is:

1. A calibration system of a digital radiography system, comprising:
a measurement tool of a predetermined length that is disposed on an electronic sensor; and
a digital radiography module that produces a digital radiographic image based on a signal from the electronic sensor, that measures a measured length of the measurement tool within the image, and that calibrates itself based on the predetermined and the measured lengths.
2. The calibration system of claim 1 wherein the measurement tool is integrated with the electronic sensor.
3. The calibration system of claim 1 wherein the measurement tool is disposed in proximity to at least one edge of the electronic sensor.
4. The calibration system of claim 1 wherein the measurement tool is disposed along at least one of a left edge, a right edge, a top edge, and a bottom edge of the electronic sensor.
5. The calibration system of claim 1 wherein the measurement tool is integrated with a cover that is fit to the electronic sensor.

6. The calibration system of claim 5 wherein the measurement tool is disposed in proximity to at least one edge of the cover that is retrofit to the electronic sensor.

7. The calibration system of claim 6 wherein the measurement tool is disposed along at least one of a left edge, a right edge, a top edge, and a bottom edge of the cover that is retrofit to the electronic sensor.

8. The calibration system of claim 1 further comprising a video connector that connects the electronic sensor and the digital radiography module.

9. The calibration system of claim 1 wherein the digital radiography module measures a measured length of an object within the image and determines a corrected length of the object based on the measured length of the object, the predetermined length, and the measured length of the measurement tool.

10. The calibration system of claim 9 wherein the digital radiography commands a display to display the corrected length.

11. The calibration system of claim 1 wherein the digital radiography module determines a correction factor based on the predetermined and the measured lengths.

12. The calibration system of claim 11 wherein the digital radiography module measures a measured length of an object within the image and determines a corrected length of the object based on the measured length of the object and the correction factor.

13. The calibration system of claim 1 wherein the digital radiography system includes at least one of a dental radiography system, a medical radiography system, a radiography system of a vehicle, and a radiography system for airport security.

14. A method of operating a calibration system of a digital radiography system, comprising:

producing a digital radiographic image based on a signal from an electronic sensor;

measuring a measured length of a measurement tool of the electronic sensor within the image; and

calibrating a digital radiography module based on a predetermined length of the measurement tool and the measured length.

15. The method of claim 14 further comprising:

measuring a measured length of an object within the image; and

determining a corrected length of the object based on the measured length of the object, the predetermined length, and the measured length of the measurement tool.

16. The method of claim 15 further comprising commanding a display to display the corrected length.

17. The method of claim 14 further comprising determining a correction factor based on the predetermined and the measured lengths.

18. The method of claim 17 further comprising:
measuring a measured length of an object within the image; and
determining a corrected length of the object based on the measured length of the object and the correction factor.

19. The method of claim 14 wherein the predetermined length of the measurement tool is a marker of known length integrated with the electronic sensor.

20. The method of claim 14 wherein the predetermined length of the measurement tool is a marker of known length integrated with a cover that fits over the electronic sensor.

1/4

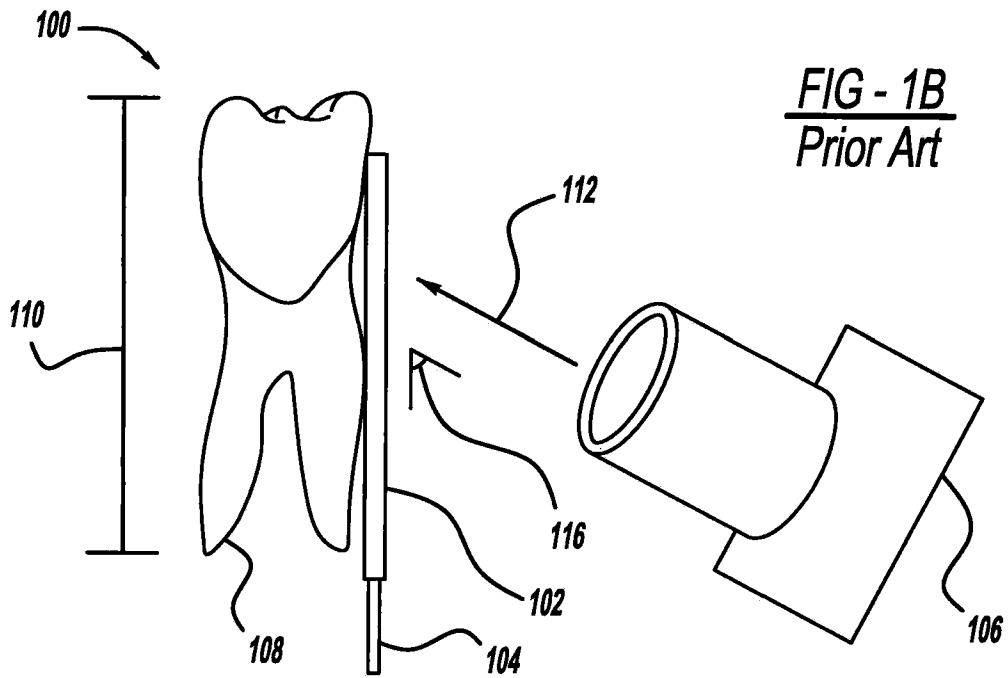
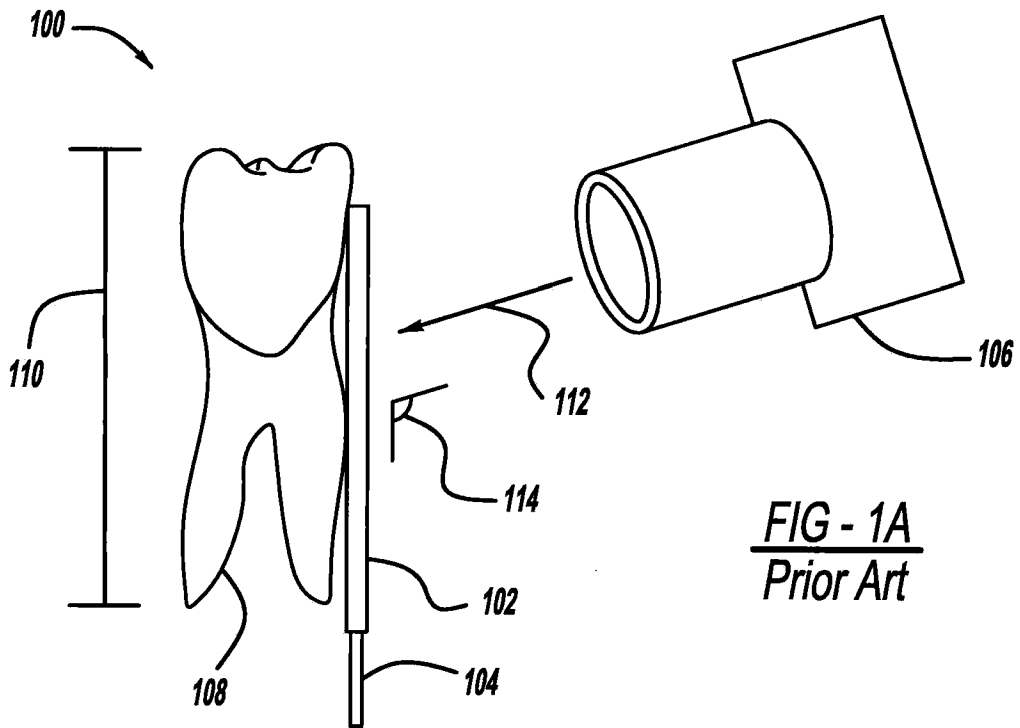

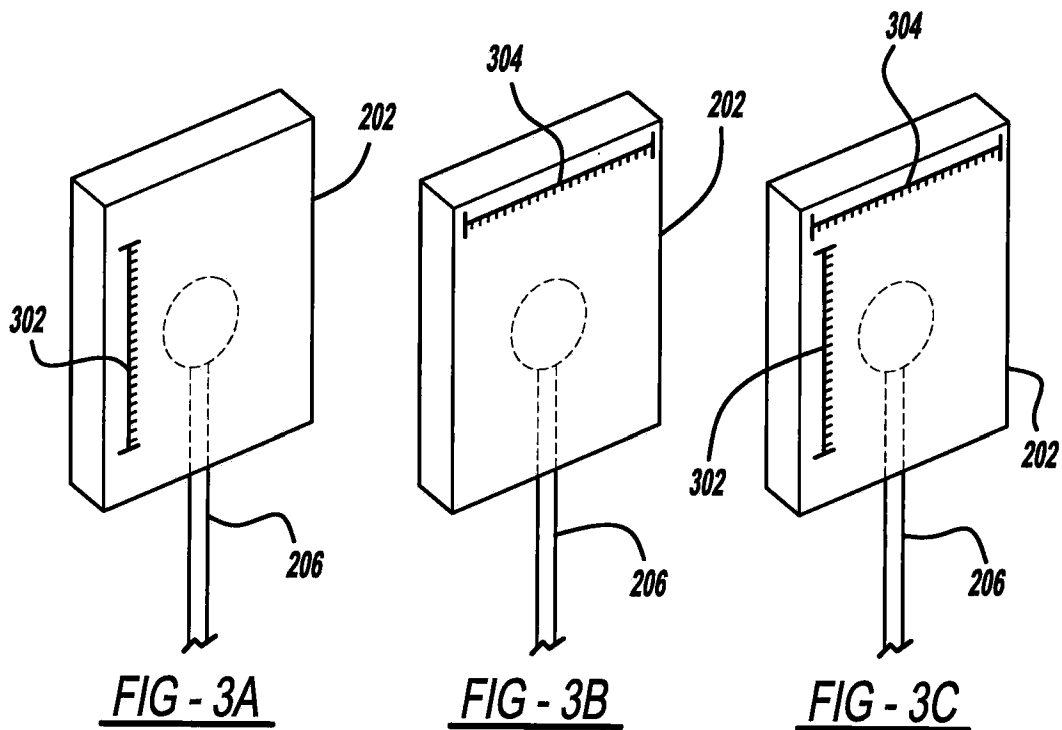
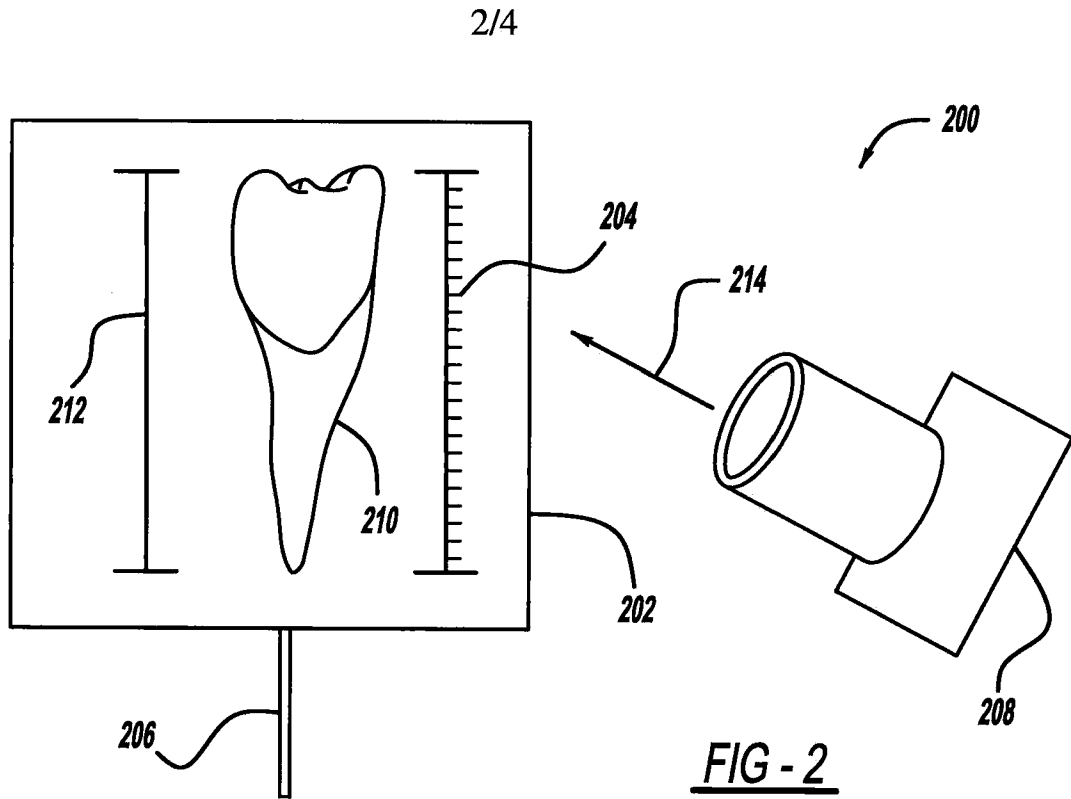

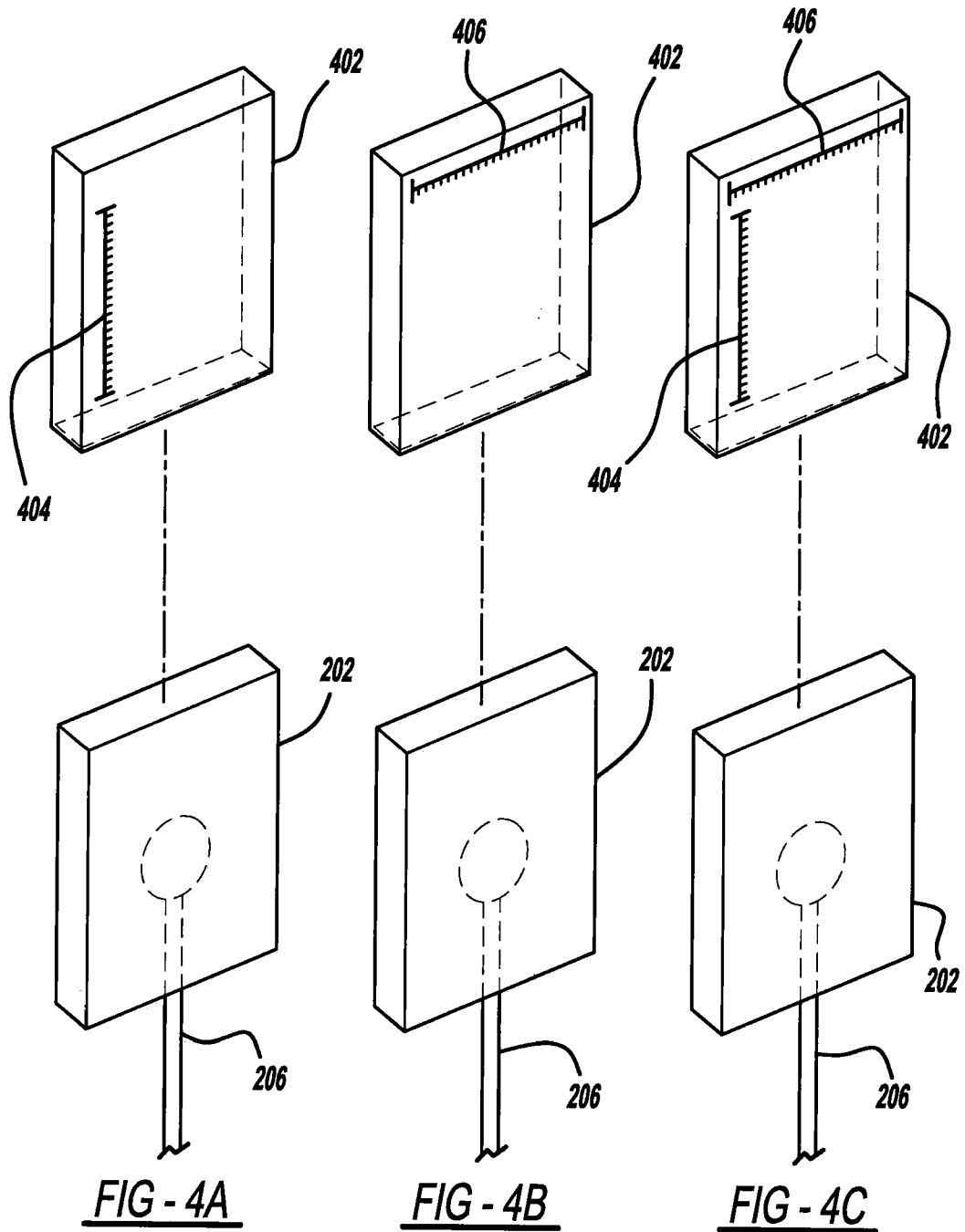

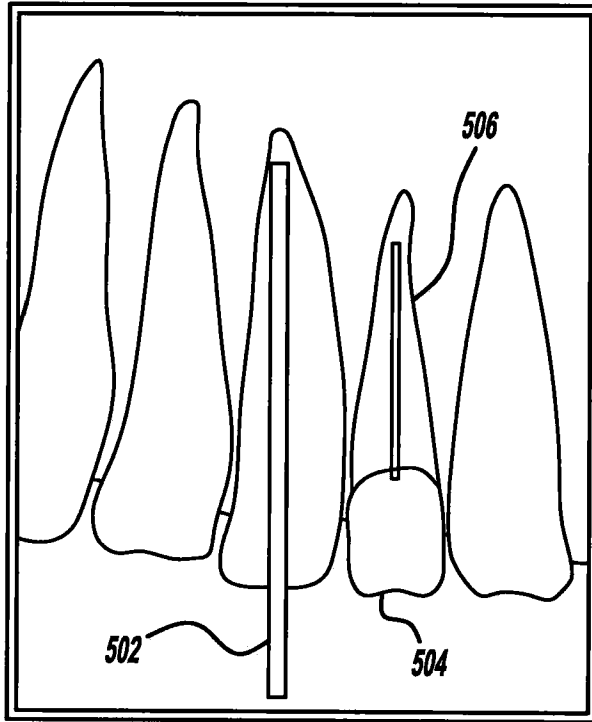

FIG - 5A

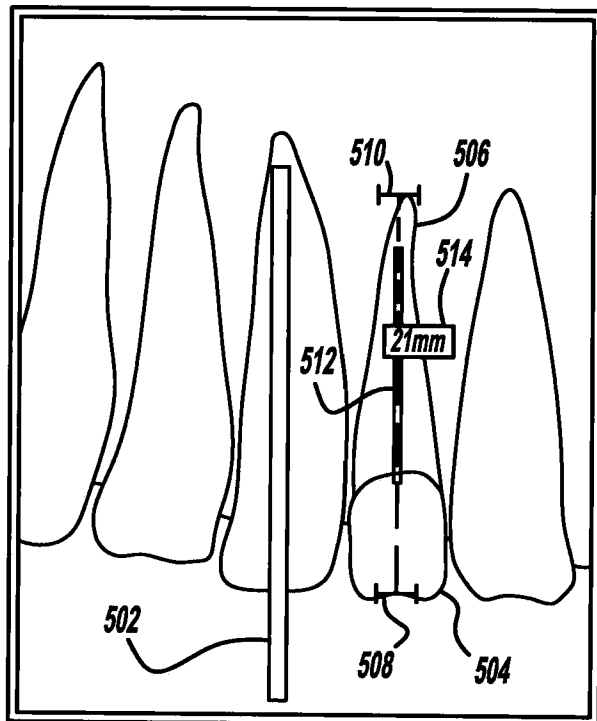

FIG - 5B

INTERNATIONAL SEARCH REPORT

International application No.

PCT/US 08/71316

A. CLASSIFICATION OF SUBJECT MATTER

IPC(8) - G01D 18/00 (2008.04)

USPC - 378/207

According to International Patent Classification (IPC) or to both national classification and IPC

B. FIELDS SEARCHED

Minimum documentation searched (classification system followed by classification symbols)

IPC: G01D 18/00 (2008.04)

USPC: 378/207

Documentation searched other than minimum documentation to the extent that such documents are included in the fields searched
USPC: 378/207 (keyword limited - see terms below)

Electronic data base consulted during the international search (name of data base and, where practicable, search terms used)

PubWest (PGPB, USPT, USOC, EPAB,JPAB); GOOGLE Scholar

Searched Terms: calibrat\$3, correlat\$3, correct\$3, length, dimension, size, width, height, dental, tooth, teeth, digital, x-ray, radiograph\$2

C. DOCUMENTS CONSIDERED TO BE RELEVANT

Category*	Citation of document, with indication, where appropriate, of the relevant passages	Relevant to claim No.
X ----	US 2006/0133579 A1 (LEE et al.) 22 June 2006 (22.06.2006), entire document, especially; Fig 4-7c, para. [0007], [0008], [0020]-[0025], [0033]	1-4, 8-19
Y		5-7, 20
Y	US 2004/0062358 A1 (LANG et al.) 01 April 2004 (01.04.2004), entire document, especially; Fig 12, para. [0013]-[0015], [0020]-[0026], [0082]-[0086]	5-7, 20

 Further documents are listed in the continuation of Box C.

* Special categories of cited documents:

"A" document defining the general state of the art which is not considered to be of particular relevance

"E" earlier application or patent but published on or after the international filing date

"L" document which may throw doubts on priority claim(s) or which is cited to establish the publication date of another citation or other special reason (as specified)

"O" document referring to an oral disclosure, use, exhibition or other means

"P" document published prior to the international filing date but later than the priority date claimed

"T" later document published after the international filing date or priority date and not in conflict with the application but cited to understand the principle or theory underlying the invention

"X" document of particular relevance; the claimed invention cannot be considered novel or cannot be considered to involve an inventive step when the document is taken alone

"Y" document of particular relevance; the claimed invention cannot be considered to involve an inventive step when the document is combined with one or more other such documents, such combination being obvious to a person skilled in the art

"&" document member of the same patent family

Date of the actual completion of the international search

22 September 2008 (22.09.2008)

Date of mailing of the international search report

26 SEP 2008

Name and mailing address of the ISA/US

Mail Stop PCT, Attn: ISA/US, Commissioner for Patents
P.O. Box 1450, Alexandria, Virginia 22313-1450
Facsimile No. 571-273-3201

Authorized officer:

Lee W. Young

PCT Helpdesk: 571-272-4300
PCT OSP: 571-272-7774