

19



**Octrooi Centrum  
Nederland**

11

**2018225**

**12 B1 OCTROOI**

21 Aanvraagnummer: **2018225**

51 Int. Cl.:

**G01R 35/00** (2017.01) **G01R 27/28** (2017.01) **G01R 31/28** (2017.01)

22 Aanvraag ingediend: **25/01/2017**

41 Aanvraag ingeschreven:  
**01/08/2018**

73 Octrooihouder(s):  
**Technische Universiteit Delft te Delft.**

43 Aanvraag gepubliceerd:  
-

72 Uitvinder(s):  
**Marco Spirito te Delft.**  
**Luca Galatro te Delft.**  
**Raffaele Romano te Delft.**  
**Faisal Ali Mubarak te Delft.**

47 Octrooi verleend:  
**01/08/2018**

45 Octrooischrift uitgegeven:  
**07/08/2018**

74 Gemachtigde:  
**ir. M.F.J.M. Ketelaars c.s. te Den Haag.**

54 **An interferometric IQ-mixer/DAC based solution for active, high speed vector network analyzer impedance renormalization**

57 Device under test (DUT) interface device for use in a system for executing measurements on a device under test (9) with a vector network analyser (11).

The DUT interface device comprises a divider/coupler component (4), a variable gain amplifier (5), an I/Q mixer (6) and a bridge/coupler component (7) and provides a test signal (a) to the DUT terminal (3).

The system further comprises a control unit (12) connected to the vector network analyser (11) and to control input terminals (8) of associated ones of the at least one DUT interface device (1).

The control unit (12) provides quadrature control signals ( $V_I V_Q$ ) for the associated at least one DUT interface device (1), which are connected directly to the device under test (9).

The present invention further relates to proper calibration and measurement methods.

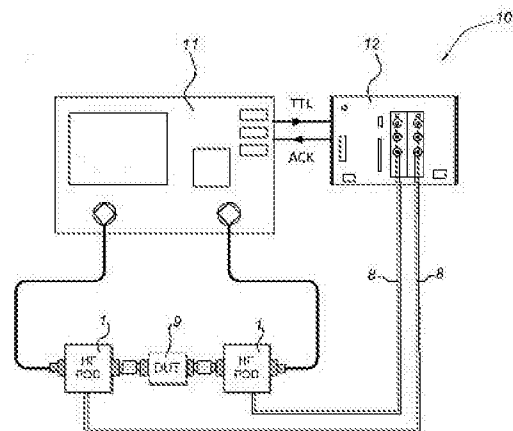

## **An interferometric IQ-mixer/DAC solution for active, high speed vector network analyser impedance renormalization**

### **Field of the invention**

5 The present invention relates to an interface device for connecting a vector network analyser to a device under test (DUT), and in a further aspect to a system for executing measurements on a device under test comprising a vector network analyser, and at least one DUT interface device according to an embodiment of the present invention. Furthermore, the present invention relates to a method for using such a system.

### **10 Background art**

In the article by G. Vlachogiannakis et al., "An I/Q-Mixer-Steering Interferometric Technique for High-Sensitivity Measurement of Extreme Impedances", International Microwave Symposium, May 2015, a vectorial signal cancellation technique based on IQ phase steering is disclosed for measurements on a device under test using a vector network analyser (VNA). The disclosed system uses a splitter on the path of the  $a_1$  signal, internally to the VNA. This implementation results in the fact that the signal driving the LO of the IQ mixer and the signal driving the DUT, propagate on different transmission lines, i.e., cables. This makes this setup very sensitive to relative phase fluctuation between the two signals, hampering the cancellation condition. Moreover, to feed back the signal inside the VNA after the splitter, allows to realize signal cancellation only for a subset of VNA's, namely the ones providing front jumpers. In the implementation disclosed in this article no synchronization between the VNA source and the DAC controlling the injection vector was realized, making frequency sweep slow since it is performed one frequency point at the time. Also, this prior art implementation used a resistive divider to create the injection signal, this solution provides no isolation between the main line and injection path, making the cancellation condition susceptible to mismatches along the lines causing reflected signals coupling on the other signal path (i.e., from main to injection path and vice versa). Furthermore, in this prior art implementation there is no capability of decoupling the power level of the main path from the one driving the IQ mixers (of passive type in the mentioned implementation) requiring a specific LO power level. This makes this prior art solution capable to operate only at fixed power level, modifying the power requires changes on the setup by means of mechanical attenuators. Finally, this prior art implementation does not consider active amplification after the IQ mixer, thus often using the mixer in the non-optimal (linear) region, since the amplitude of the injected vector is only defined by the IQ signals.

### **35 Summary of the invention**

The present invention seeks to provide improved test set-up arrangements for high frequency measurements of (active) devices (device under test, DUT), which is less susceptible to distortions and more robust during operation, especially suited for devices having a high reflection

coefficient ( $\Gamma$ ). In present measurement systems and methods, such a high  $\Gamma$  DUT will usually result in problems for performing accurate and repeatable measurements.

According to the present invention, a device under test (DUT) interface device is provided as described above, wherein the DUT interface device comprises an analyser terminal, a DUT terminal and a control input terminal, a divider/coupler component having a main terminal connected to the analyser terminal, a variable gain amplifier connected to a first branch terminal of the divider/coupler component, an I/Q mixer having an input terminal connected to an output terminal of the variable gain amplifier, a bridge/coupler component, of which first branch terminals are connected between a second branch terminal of the divider/coupler component and the DUT terminal for providing a test signal  $a$  to the DUT terminal, and second branch terminals are connected between an output of the I/Q mixer and a grounding impedance. This set-up allows the DUT interface device to be positioned directly adjacent the DUT, and as a result the components of the DUT interface device as well. This results in a much lower susceptibility to external distortions and hence better performance of actually testing a DUT, especially when the DUT has a high  $\Gamma$  coefficient.

In a further aspect, the present invention relates to a system as defined above, wherein the DUT interface device is connected to an associated measuring port of the vector network analyser. The system further comprises a control unit connected to the vector network analyser and to control input terminals of associated ones of the at least one DUT interface device, wherein the control unit is arranged to provide quadrature control signals for the associated at least one DUT interface device. The at least one DUT interface device is connected directly to the device under test DUT. In a further aspect the (DC) quadrature control signals are generated by a digital to analogue converter and can vary synchronously to the frequency of the vector network analyser through a hardware trigger loop, allowing quasi real time frequency sweeps with signal cancellation.

In an even further aspect, the present invention relates to a method for using a system according to an embodiment of the present invention, wherein the system comprises a DUT interface device connected to a first measuring port of the vector network analyser. The method comprises calibrating the system by obtaining injection signal parameters and vector calibration coefficients to allow measurements of a device under test connected to the DUT interface device. The method comprises a calibration part wherein the proper injection signals for the DUT interface devices are determined, and optionally an actual measurement step, in which the proper injection signals are used, and which make the method especially suitable for a DUT having a high  $\Gamma$  coefficient.

35

### Short description of drawings

The present invention will be discussed in more detail below, with reference to the attached drawings, in which

Fig. 1 shows a schematic diagram of a prior art test set-up using an interferometric technique;

40

Fig. 2 shows a further prior art DUT set-up arrangement using an interferometric technique;

Fig. 3 shows a schematic diagram of an embodiment of a DUT interface device according to an embodiment of the present invention;

5 Fig. 4 shows a schematic diagram of a test set-up arrangement according to a further aspect of the present invention;

Fig. 5A-5C show flow charts of calibration/measurement method embodiment groups as used for the test set-up arrangement of Fig. 4;

10 Fig. 6 shows a flow chart for a test sequence using the test set-up arrangement of Fig. 4.

### Description of embodiments

High frequency devices are characterized by their reflection ( $\Gamma$ ) and transmission coefficients when driven from input and/or output, often represented in the S-parameter formalism when a vector correction is applied to the measurement instrument. Characterization of the device under test (DUT exhibiting a large voltage standing wave ratio (VSWR) condition, i.e.

$$(1+|\Gamma|)/(|\Gamma|-1) > 9,$$

(representing a  $|\Gamma|=0.8$  and real impedances smaller than  $5.5 \Omega$  and larger than  $450 \Omega$ ),

15 result in an increased uncertainty of the measured impedance (i.e.,  $Z$ ), i.e., higher than two order of magnitude compared to the zero VSWR case. Thus, extreme impedances (i.e., falling under the VSWR>9 category), in respect to the system impedance (generally  $50\Omega$ ), present a big challenge for high frequency characterization.

The reason for this can be easily found observing the relation between the device impedance and the instrument measured parameter, i.e.,  $\Gamma$  vs.  $Z$ . For impedance levels between a few  $\Omega$ 's and a few hundredths  $\Omega$ 's the derivative of the reflection coefficient versus impedance ( $\delta \Gamma / \delta Z$ ) is high, resulting in a compression of the measured noise. When the impedance levels are shifted to the ones providing a VSWR larger than 9 the  $\delta \Gamma / \delta Z$  derivate approaches zero, resulting in an expansion of the measured noise providing large uncertainty in DUT impedance value. E.g. the relative uncertainty of the measured impedance may increase more than two orders of magnitudes for impedance levels lower than  $5.5\Omega$  and higher than  $450\Omega$ .

30 In order to provide low uncertainty measurements under high VSWR conditions, various techniques have been proposed to cancel the large reflecting wave scattered by the DUT during testing, i.e., transforming the device back to a low VSWR case. These techniques can be grouped based on the implemented method:

1) matching approaches (i.e., transforming the impedance using passive elements),

35 2) interferometric techniques, i.e., cancelling the reflected signal with a signal with similar amplitude and opposite phase.

Several interferometric techniques to achieve impedance renormalization of a one-port VNA are known in the art. An exemplary test set-up using a network analyser 21 is shown in the schematic view of Fig. 1. The driving signal  $a_1$  in Fig. 1 originating from oscillator 22 is first split in two equal-power branches using splitter 24. One of the splitter branches is used to drive the DUT

40

29 through a directional coupler 26a in order to provide an incoming signal  $a_{inc}$  at the plane 28 of the DUT 29. The reflected signal  $a_{refl}$  is then fed back via a (phase shifting) cable 27. The other branch of the splitter 24 is connected to a variable attenuator 25 and used as a cancellation signal using an upper directional coupler 26b. The cancellation signal is combined with the reflected  
5 signal  $a_{refl}$  from the DUT 29 creating the (low level) signal  $a_3$ . This signal  $a_3$  is amplified using amplifier 30 and input as measurement signal  $a_4$  to a receiver input 23 of the network analyser 21.

The large electrical distance between the injection point of the cancellation signal (at the upper directional coupler 26b) and the DUT 29 (i.e., due to cables 27 and two directional couplers 26a, 26b) makes the cancellation condition extremely sensitive to system variations (i.e., phase  
10 and amplitude due to cable 27 movements and temperature fluctuations). Moreover the use of only a variable attenuator 25 makes the cancellation condition possible only at specific frequencies i.e., frequencies at which the phase of the injected signal is opposite to the phase of the reflected signal at the plane of  $a_3$ .

As mentioned above, in the article G. Vlachogiannakis, H.T. Shivamurthy, et al., "An I/Q-  
15 Mixer-Steering Interferometric Technique for High-Sensitivity Measurement of Extreme Impedances", International Microwave Symposium, May 2015, an interferometric (cancellation) technique based on IQ phase steering is disclosed. Fig. 2 shows a schematic diagram of a test set-up 40 using this interferometric technique. The system uses a splitter 42 on the path of the  $a_1$  signal (i.e. the generated test signal), external to the (vector) network analyser, VNA, 41. In Fig. 2  
20 the splitter 42 is shown as being implemented external to the VNA 41, requiring suitable front terminals (jumpers) on the VNA 41 to allow feedback of the (split) signal to the VNA 41. The other part of the (split) signal from splitter 42 is fed to an amplifier 43 as an input to an IQ mixer 44. Under control of two control voltages  $V_{DC,I}$  and  $V_{DC,Q}$  and two mixers 45, 46 and a phase shifter 47 as internal components of the IQ mixer 44, an injection signal  $b_{inj}$  is provided to a coupler 48. The  
25 other ports of the coupler 48 are connected to the VNA 41 port (receiving the  $a'$  signal), a terminating impedance 50, and the DUT 49 (depicted as impedance  $Z_{DUT}$ ).

This implementation of the test set-up 40 results in the fact that the signal driving the LO of the IQ mixer 44 and the signal driving the DUT 49, propagate on different transmission lines, i.e., cables. This makes this setup very sensitive to relative phase fluctuation between the two  
30 signals, hampering the cancellation condition, since small variations on large vectors cause a large residual vector difference which corresponds to the  $b'$  wave in Fig. 2. Moreover, splitting the signal, and feeding back the signal inside the VNA 41, allows to realize impedance normalization only for a subset of VNAs, namely the ones providing front jumpers. The usage of a resistive splitter does not provide isolation arising from mismatches at the input port of PA 43, increasing  
35 the unwanted coupling between the signal driving the DUT 49 and the LO of the IQ mixer 44. Furthermore, the mentioned implementation does not provide the capability to vary the power driving the DUT 49 without modifying the setup, i.e., changing the attenuation/amplification to the IQ mixer 44, since the LO port of the mixer needs to be driven at the proper power level to optimize performance, (e.g. with respect to conversion losses). The amplitude of the cancellation  
40 vector is directly set from the  $V_{DC,I}$  and  $V_{DC,Q}$  signals, imposing a larger linearity from the IQ mixer

and making the cancellation algorithm more sensitive due to amplitude to phase non-linearities arising from the mixer (AM to PM conversion). Finally, in the implementation of Fig. 2 no hardware synchronization between the VNA 41 source and the DAC controlling the injection vector  $V_{DC,I}$  and  $V_{DC,Q}$  was realized, making frequency sweep slow since it is performed one frequency at the time.

5           The present invention embodiments provide solutions to the disadvantages associated with prior art set-ups as discussed above. Fig. 3 shows a schematic diagram of a DUT interface device 1 (or High Gamma pod, HГ-pod) according to an embodiment of the present invention, and Fig. 4 shows the system 10 set-up for executing test of a DUT 9 with a vector network analyser 11, in a two-port configuration. Each DUT interface device 1 is a two port device, allowing to  
10 realize a signal cancellation loop, and allowing its use with any commercially available multiport VNA 11.

In general, the present invention relates to a device under test (DUT) interface device 1 (or high gamma (HГ)-pod) for connecting a vector network analyser 11 to a device under test 9. The DUT interface device 1 comprises an analyser terminal 2, a DUT terminal 3, and a control  
15 input terminal 8. A divider/coupler component 4 is present having a main terminal connected to the analyser terminal 2, a variable gain amplifier 5 is connected to a first branch terminal of the divider/coupler component 4, and an I/Q mixer 6 is present having an input terminal connected to an output terminal of the variable gain amplifier 5. Furthermore, a bridge/coupler component 7 is present, of which first branch terminals are connected between a second branch terminal of the  
20 divider/coupler component 4 and the DUT terminal 3 for providing a test signal a to the DUT terminal 3, and second branch terminals are connected between an output of the I/Q mixer 6 and a grounding impedance 7a. Such a DUT interface device 1 having all relevant elements for the intended purpose, allows a connection close to the DUT 9, and hence a better performance for measurements, as the relevant leads and connections are close to the DUT 9.

25           In a further embodiment, an additional power amplifier may be added receiving an output from the I/Q mixer 6, and providing an amplified signal to the bridge/coupler component 7. This allows to further optimize the I/Q linearity.

In an embodiment, the I/Q mixer 6 is arranged to generate an injection signal  $b_{inj}$  which is coherently combined with a reflected signal b received on the DUT terminal 3. Again, as this takes  
30 place in the DUT interface device 1 close to the DUT, it will be less likely that errors or interference occurs. More in particular, the cancellation is close to the DUT 9 thus the sensitivity of the cancellation condition, due to vibration or changes in the setup is less pronounced. In an even further embodiment, the I/Q mixer 6 (and optionally the variable gain amplifier 5) is connected to the control input terminal 8. This allows to use proper wiring to run to the DUT  
35 interface device 1, which as a result will be less susceptible to distortion or other error introducing effects. Since all the loops are incorporated near the DUT 9, the LO and RF path are coupled, thus creating phase fluctuation (which in effect are the ones leading to the errors in the interferences) coherent which do ratio out in the cancellation condition.

In an even further embodiment, the variable gain amplifier 5 comprises a plurality of  
40 variable attenuators. The presence of the variable gain amplifier 5, possibly in the form of variable

or switchable attenuators, allows to independently control power between the RF signal to the DUT 9 and the local oscillator signal in the I/Q mixer 6, which allows to optimize the drive level of the I/Q mixer 6 and at the same time providing independent power control towards the DUT 9 (via the signal generated from the analyser terminal 2). In an even further embodiment this is implemented using an integrated circuit digitally controlled variable attenuator, obviating any switching parts.

A simplified schematic view of the DUT interface device 1 (HF pod) according to a present invention embodiment is shown in Fig. 3. The DUT interface device 1 comprises two terminals 2, 3 and a control signal input 8, as a single, compact unit. In the DUT interface device 1, after the input terminal 2 a high directivity power divider/coupler 4 is placed to split the test signal  $a$  wave between two different paths (indicated by numerals 1 and 2 in circles). In other terms, the divider/coupler component (4) is a high directivity power divider/coupler splitting a test signal on the main terminal over the first and second branch terminal.

In the specific embodiment shown in Fig. 3, the signal at port 1 of the divider/coupler 4 serves as test signal  $a$  to stimulate the DUT 9 via output terminal 3. The signal at port 2 of the divider/coupler 4 is used to generate the phase coherent cancellation signal  $b_{inj}$  required to cancel the scattered wave  $b$  originating from the DUT 9 during the execution of a test. The split signal part (or wave) at port 2 of the divider coupler 4 is first amplified, using a variable gain amplifier 5, to an adequate level (i.e., to toggle the switching core of the mixer) and is then used as the local oscillator (LO) signal of an IQ mixer 6. The IQ mixer 6 comprises internal components (mixers 6a, 6b and phase shifter 6c) which as such are known to the person skilled in the art.

As mentioned above, in a further embodiment, an additional (variable gain) amplifier is added at the output of the IQ mixer. This allows to optimize the linearity of the I/Q mixer 6, e.g. by not having the output of the I/Q mixer 6 go higher than the optimal linear range of the mixer (and using the additional amplifier to get a sufficiently high signal level. Also, it is then possible to keep the output of the I/Q mixer 6 at a sufficiently high level (not at levels comparable to DC signal noise levels (quantization noise), even if a lower level is desired at the bridge/coupler component 7 (then using an attenuation by the additional amplifier).

As shown in the system view of Fig. 4, the in-phase ( $V_I$ ) and quadrature-phase ( $V_Q$ ) signals of the control signal input 8 are sourced with accurate DC signals generated with high bit count digital to analogue converters (DACs) in DAC signal generator 12. The  $V_I$  and  $V_Q$  signals are used to steer the phase and control the amplitude of the injection signal (i.e., Cartesian modulation). The generated cancellation signal  $b_{inj}$  is injected into path 1 of the divider coupler 4 in the same direction of the scattered wave  $b$  with a high directivity coupler 7 (of which the fourth port is coupled to a termination impedance 7a). The VNA 11 and the DAC signal generator 12 are placed inside a trigger/acknowledge loop using the indicated TTL and acknowledge (ACK) signal. During a frequency sweep the VNA 11 will change internal PLL sources to the next frequency in the sweep and send a TTL trigger to the signal generator 12 to set the proper values of the control signal input signals  $V_I$  and  $V_Q$  to generate the cancellation signal  $b_{inj}$  for that specific frequency. The DAC signal generator 12 will send an ACK signal to initiate the VNA measurement. After this

measurement, the VNA 11 will move to the next frequency and re-initiate the trigger/acknowledge protocol.

Therefore, the present invention in a further aspect relates to a system for executing measurements on a device under test (DUT) 9, comprising a vector network analyser 11, at least one DUT interface device 1 (HF-pod) according to any one of the present invention embodiments connected to an associated measuring port of the vector network analyser 11, and a control unit 12 connected to the vector network analyser 11 and to control input terminals 8 of associated ones of the at least one DUT interface device 1 (HF-pod). The control unit 12 is arranged to provide quadrature control signals  $V_I$ ,  $V_Q$  (i.e. synchronized I/Q mixer signals) for the associated at least one DUT interface device 1, wherein the at least one DUT interface device 1 is connected directly to the device under test 9. Thus, as compared to prior art systems, the loops in the measurement system are set-up differently, which improves performance. No longer is it necessary to provide a split of signals inside the vector network analyser 11. In the prior art solution the split is very far from the actual DUT loop creating several problems for the cancellation stability. Additionally, such an approach is making it very difficult to achieve two port configuration in conventional vector network analysers.

In a further embodiment, the control unit 12 comprises (high bit count) digital-to-analogue converters to provide quadrature control signals  $V_I$ ,  $V_Q$  for each of the at least one DUT interface device 1. The vector network analyser 11 is connected to the control unit 12 using a synchronization interface for executing frequency sweeps. E.g. the synchronization interface comprises a control signal (TTL) and an acknowledgment return signal (ACK), as discussed above.

According to a further aspect of the present invention, a method is provided for using a system according to any one of the embodiments described above, wherein the system comprises a DUT interface device 1 according to any one of the embodiments described herein connected to a first measuring port of the vector network analyser 11. The method comprises calibrating the system by obtaining injection signal parameters to allow measurements of a device under test 9 connected to the DUT interface device 1. Actual measurements of a device under test (DUT) 9 can then be executed by using the obtained injection signal parameters to control the DUT interface device 1 (i.e. with injection signal on).

In accordance with further embodiments, one of three different calibration methods are provided to obtain various effects. In a first group of embodiments (labelled as method M1 in the following), measurement sensitivity at high gamma loads is improved (i.e. reduced trace noise), as shown in the flow schedule of Fig. 5A. In a second group of embodiments (labelled as method M2 in the following), absolute measurement accuracy at high gamma loads is improved by employing dedicated calibration structures, i.e., high gamma standards, as shown in the flow schedule of Fig. 5B. In a third group of embodiments (labelled as method M3 in the following), both absolute accuracy and sensitivity are improved by employing a combination of methods M1 and M2, as shown in the flow schedule of Fig. 5C.

The three groups of calibration procedures (methods M1, M2, M3) can be applied to a one port or a two port measurement system, following the description presented below.

Calibration method embodiments are provided for the test set-up arrangement of Fig. 4, for which the flow charts are shown in Fig. 5A, 5B and 5C. The setup calibration is based on a short-open-load (SOL) technique, to be applied to port one of a network analyser 11 only (one port DUT 9) or both port one and two of the network analyser 11 (two ports DUT 9). In order to extract consistent error terms to allow the measurement of full two-port error corrected scattering parameters (i.e., normalized to 50  $\Omega$ ) the injection signals are turned on and off at specific moments during the procedure as with reference to Fig. 5A, 5B and 5C.

Fig. 5A shows a flow chart for the first group of embodiments (method M1). This method comprises:

- (block 50) perform a short-open-load calibration on the first measuring port of the vector network analyser 11 with the injection signal  $b_{inj}$  off,
- (block 51) calculating 50 $\Omega$  error terms (i.e., system error terms  $e_{00}$ ,  $e_{11}$ ,  $e_{10}e_{01}$ ),
- (block 52) connecting the device under test 9,
- (block 53) compute input reflection coefficient  $\Gamma_{in,50}$  of the device under test 9 in a 50  $\Omega$  environment.
- (block 54) determine required quadrature control signals  $V_i$ ,  $V_Q$  to minimize the input reflection coefficient  $\Gamma_{in,50}$  (using e.g. an iteration algorithm).

Fig. 5B shows a flow chart for the second group of embodiments (method M2). This method comprises:

- (block 55) connecting a high gamma load as device under test 9 to the first measuring port of the vector network analyser 11 via the first DUT interface device 1,
- (block 56) determine required quadrature control signals  $V_i$ ,  $V_Q$  to minimize the reflection coefficients  $\Gamma_{raw}$ ,
- (block 57 and 58) perform a short-open calibration on the first measuring port of vector network analyser 11 with the injection signal  $b_{inj}$  on, and
- (block 59) compute system error terms ( $e_{00\_HG}$ ,  $e_{11\_HG}$ ,  $e_{10}e_{01\_HG}$ ) in high gamma condition (i.e., injection signal on) for the first measuring port of the vector network analyser 11.

Both the method groups M1 and M2 may be applied for a two port DUT 9. To that end the system comprises a further DUT interface device connected to a second measuring port of the vector network analyser 11. The steps as described above are then repeated for the second measuring port of the vector network analyser (11).

Fig. 5C shows a flow chart for the third group of embodiments (method M3). This method comprises, in addition to the sequence of blocks 55-59 as described with reference to Fig. 5B: connecting the further DUT interface device 1 (block 52) and then determining the second injection signal (block 60).

As shown in the flow charts of Fig. 5A-5C, the calibration steps can then be followed by an actual measurement step 70 of the DUT 9, with the injection signal(s)  $b_{inj}$  as determined in the calibration steps.

In more generic terms, a method embodiment is provided for calibrating a system according to any one of the system embodiments described herein, wherein the system comprises two DUT interface devices 1 connected to two measuring ports of the vector network analyser 11. The method comprises:

- 5 (a) connecting a high gamma load as device under test 9 to a first measuring port of the vector network analyser 11 via a first DUT interface device 1, (note that this is not used in method M1).
- (b) determine required quadrature control signals  $V_I$ ,  $V_Q$  to minimize the reflection coefficients  $\Gamma_{raw}$ , (note that this is not used in method M1).
- (c) perform a short-open-load calibration on the first measuring port of the vector network analyser 11 with the injection signal  $b_{inj}$  off, (i.e. wherein the load is a standard system value, e.g. a 50 $\Omega$  load).
- 10 (d) compute 50 $\Omega$  system error terms  $e_{00}$ ,  $e_{11}$ ,  $e_{10}e_{01}$  for the first measuring port of the vector network analyser 11,
- (e) perform a short-open calibration on the first measuring port of vector network analyser 11 with the injection signal  $b_{inj}$  on (again, note that this is not used in method M1).
- 15 (f) compute HG system error terms  $e_{00\_HG}$ ,  $e_{11\_HG}$ ,  $e_{10}e_{01\_HG}$  for the first measuring port of the vector network analyser 11, (note that this is not used in method M1),
- repeating steps (a)-(e) for the second measuring port of the vector network analyser 11.
- (g) in the case of method groups M1 and M3, the procedure is followed by determining at each 20 frequency point the required  $V_I$ ,  $V_Q$  to minimize the reflection coefficients  $\Gamma_{in}/\Gamma_{out}$  of the DUT 9.

In a further embodiment, in step (b) the required quadrature signals  $V_I$ ,  $V_Q$  are determined for a range of frequencies of interest, i.e. a number of discrete frequencies in a frequency range. The method may further comprise computing two-port scattering parameters of the high gamma load as device under test 9 by using a thru connection between the first and second measuring 25 port of the vector network analyser 11, with the injection signal ( $b_{inj}$ ) off. These method embodiments are specifically advantageous in that both measurement ports are being calibrated, taking into account specific issues in relation to the use of two measurement ports of the vector network analyser 11.

The above mentioned generic calibration method embodiments are clarified and further 30 detailed in the following description.

The widely used short-open-load (SOL) method for calibration of one-port vector network analysers relies on three pre-characterized calibration devices used as device under test 9. The transfer function between uncorrected  $\Gamma_{raw}$  and corrected  $\Gamma$  reflection coefficient is determined through three error terms  $e_{00}$ ,  $e_{11}$ , and  $e_{10}e_{01}$ , and  $\Gamma$  at the calibration reference plane can be 35 calculated using the following expression:

$$\Gamma = \frac{\Gamma_{raw} - e_{00}}{e_{10}e_{01} + e_{11} \cdot (\Gamma_{raw} - e_{00})} \quad (1)$$

Here, the error terms  $e_{00}$ ,  $e_{11}$ , and  $e_{10}e_{01}$  respectively represent directivity, source match, and reflection tracking of the calibrated VNA 11. The SOL method relies on the use of three 40 calibration devices with known electrical properties  $\Gamma_i$ , resulting in three independent

measurements  $\Gamma_{raw(i)}$  with three unknown error-terms, which are calculated using the following equation:

$$\begin{bmatrix} 1 & \Gamma_1 \cdot \Gamma_{raw1} & -\Gamma_1 \\ 1 & \Gamma_2 \cdot \Gamma_{raw2} & -\Gamma_2 \\ 1 & \Gamma_3 \cdot \Gamma_{raw3} & -\Gamma_3 \end{bmatrix} \cdot \begin{bmatrix} e_{00} \\ e_{11} \\ \Delta \end{bmatrix} = \begin{bmatrix} \Gamma_{raw1} \\ \Gamma_{raw2} \\ \Gamma_{raw3} \end{bmatrix} \quad (2)$$

$$5 \quad \Delta = e_{00}e_{11} - e_{10}e_{01}$$

The calibration procedure is as follows (see also flow charts of Fig. 5B and 5C):

The impedance standard of interest HighGamma<sub>load</sub> (HΓ) is connected to the system test-port (block 55). The measurement software uses an iteration algorithm (e.g. the Newton-Raphson algorithm, as such known to the person skilled in the art) to minimize  $\Gamma_{raw}$  to zero (e.g. at every desired frequency, block 56) and stores the corresponding  $V_i(f)$  and  $V_o(f)$  values (this step does not apply to calibration method M1, see Fig. 5A).

A first SOL calibration with injection signal  $b_{inj}$  turned off is performed (applies to all method groups M1-M2-M3).

15 A conventional SOL calibration method is used (block 59) for calculation of system error terms, see equation (2), with injection off ( $e_{term\_50}$ ).

The second SOL calibration is performed with the measurement of three calibration devices with suitable electrical properties to improve accuracy over the impedance measurement range of interest, the HΓ, and two other known device typically the short (S) and the open (O).

20 This applies to method groups M2 and M3 only. Again, a conventional SOL calibration method is used for calculation of system error terms, see equation (2), with injection on ( $e_{term\_HG}$ ).

The standard definition of the short and the open is converted in the gamma plane of the new reference impedance, i.e., where HighGamma<sub>load</sub> (HΓ) is now zero. Considering  $Z_1$  the original reference impedance and  $Z_2$  the new reference impedance, the scattering matrix  $S_i$  associated to either the short or the open standard in  $Z_1$  is converted in the new reference plane using the equation:

$$S' = P^{-1}(S - \gamma)(I - \gamma S)^{-1}P$$

wherein:

$$30 \quad P = \sqrt{\frac{Re(Z_1)}{Re(Z_2)} \left| \frac{Z_1}{Z_2} \right|} \frac{2Z_1}{Z_1 + Z_2}$$

$$\gamma = \frac{Z_2 - Z_1}{Z_2 + Z_1}$$

and S is the scattering matrix in the old reference system and S' is the new reference system (i.e., high gamma), I is the identity matrix.

– The same procedure is then repeated for port two.

With the system error-terms known, equation (1) is used to correct the input and output reflection coefficient of the high gamma device with injection on.

In order to compute the two-ports scattering parameters of the extreme gamma device the load match ( $e_{22}$ ) and transmission tracking term ( $e_{10}e_{32}$ ) are then computed.

In order to obtain improved two port parameters of a high  $\Gamma$  device (i.e., reduced mismatched uncertainty and increased absolute accuracy of the reflection coefficients, using method group M3), after the above described calibration the measurement procedure is as follows, see Fig. 6 for the flow graph representation:

- 0) Connect the two-port high  $\Gamma$  DUT 9 (step 62)
- 1) Turn on the cancellation signal at port one, and acquire the raw input reflection coefficient  $\Gamma_{INraw}$  (step 63, sparse dot pattern)
- 2) Turn on the cancellation signal at port two, and acquire the raw output reflection coefficient  $\Gamma_{OUTraw}$  (step 64, dense dot pattern)
- 3) Turn the injection signals off and acquire  $S_{12raw}$  and  $S_{21raw}$  (step 65)
- 4) Correct the input/output reflection coefficients ( $\Gamma_{IN}$  and  $\Gamma_{OUT}$ ) using eq. (1) and  $e_{term\_HG}$  (step 66)
- 5) Correct the S21 and S12 using two port calibration equation (see above) and  $e_{term\_50}$  (step 67)
- 5) Use the following eq. (4) to obtain the normalized scattering parameters of the high  $\Gamma$  DUT 9 (step 68)

$$s_{11} = \frac{1}{2} \frac{1}{e_{22R}(e_{22F}\Gamma_{OUT} - 1)} (e_{22F}e_{22R}\Gamma_{IN}\Gamma_{OUT} + \Gamma_{OUT}e_{22F} - e_{22R}\Gamma_{IN} - 1 + \sqrt{(e_{22R}\Gamma_{IN} - 1)(e_{22F}\Gamma_{OUT} - 1)(e_{22F}e_{22R}\Gamma_{IN}\Gamma_{OUT} + 4e_{22F}e_{22R}S_{12}S_{21} - \Gamma_{OUT}e_{22F} - e_{22R}\Gamma_{IN} + 1)})$$

$$s_{22} = \Gamma_{OUT} - \frac{s_{12}s_{21}e_{22R}}{1 - s_{11}e_{22R}}$$

(4)

- 25 Where the error terms in (4) are  $e_{term\_50}$ .

If the method M1 is applied for a two port DUT 9 measurement (using a further DUT interface device 1) the following method steps may also describe this method M1:

connecting a high gamma load as device under test 9 to the two measuring ports of the vector network analyser 11 via associated DUT interface devices 1, (block 62);

- 30 acquiring corrected two port S-parameters of the DUT with injection off, and using 50  $\Omega$  error terms, derive the  $V_I$  and  $V_O$  signals to cancel the corrected input and output reflection coefficient, i.e., identify the cancellation signal  $b_{inj}$ . Furthermore, renormalizing the S-parameter to a given reference impedance may be performed (block 68).

- 35 Also method M2 may be applied for a two-port DUT 9, with the following modifications to the method M2 (with reference to the blocks identified in Fig. 6):

acquiring corrected  $\Gamma_{IN}$  and  $\Gamma_{OUT}$  parameters of the DUT with injection on, and using the High Gamma error terms (block 63, 64),

acquiring scattering parameters  $S_{12_{\text{raw}}}$ ,  $S_{21_{\text{raw}}}$  with injection signals  $b_{\text{inj}}$  to both measuring ports off (block 65),

correcting the acquired parameters using the system error terms obtained from the method for calibration (block 66, 67),

- 5 obtaining normalized scattering parameters for the high gamma load as device under test 9 (block 68).

The method group M3 can in this respect be seen as a repeat of the procedure of method group M2 and then derive the  $V_I$  and  $V_O$  signals to cancel the corrected input and output reflection coefficient, i.e., identify the cancellation signal  $b_{\text{inj}}$ , followed by renormalizing the S-parameter to a given reference impedance.

10

When considering a frequency sweep of the DUT 9, due to the reactive parasitic and delays involved, the measured impedance (at any port) will vary versus frequency, in many cases going from a high gamma value at lower frequencies to a lower gamma value at higher frequencies.

15

In a further embodiment of the present invention, a decision making algorithm is added to the method embodiments, based on the system sensitivity. The decision making algorithm was developed to choose, during the post processing phase of the measurement, which data will provide a lower uncertainty.

20

The algorithm is based on computing the derivative of the magnitude of the reflection coefficient (normalized to  $50\Omega$ ) in respect of the magnitude of  $Z$ , this quantity will be defined as  $\Delta$ . The system settings (injection off versus injection on) providing the highest value of  $\Delta$  for any given impedance will provide the highest sensitivity and thus lowest uncertainty, and will be used to further process the data. Thus, in a further embodiment of the measurement method the measurement of a device under test (DUT) is executed at a predetermined frequency with or without injection signals  $b_{\text{inj}}$  in dependence of a sensitivity parameter  $\Delta$ , the sensitivity parameter  $\Delta$  being defined as the derivative of the magnitude of the reflection coefficient  $\Gamma$  in respect of the magnitude of the load impedance  $Z$ .

25

In an example  $\Delta$  is computed for a (standard)  $50\Omega$  system and the system with injection on (i.e.,  $1K\Omega$  in the specific case). Depending on the value of  $\Delta$  the data from the  $50\Omega$  system may provide a higher sensitivity, or the data from the  $1K\Omega$  system will provide a higher sensitivity, and a selection is made accordingly.

30

It is noted that the present invention embodiments are advantageously applicable when the high gamma load, in operation, has a high voltage standing wave ratio (as compared to normal system impedance of  $50\Omega$ ), e.g. a voltage standing wave ratio is higher than 9.

35

The present invention embodiments, as described above with reference to a number of exemplary embodiments, can be summarized in the following numbered and interdependent embodiments:

Embodiment 1. Device under test (DUT) interface device for connecting a vector network analyser (11) to a device under test (9), comprising

40

an analyser terminal (2), a DUT terminal (3), and a control input terminal (8),

a divider/coupler component (4) having a main terminal connected to the analyser terminal (2),  
a variable gain amplifier (5) connected to a first branch terminal of the divider/coupler component (4),

5 an I/Q mixer (6) having an input terminal connected to an output terminal of the variable gain amplifier (5),

a bridge/coupler component (7), of which first branch terminals are connected between a second branch terminal of the divider/coupler component (4) and the DUT terminal (3) for providing a test signal (a) to the DUT terminal (3), and second branch terminals are connected between an output of the I/Q mixer (6) and a grounding impedance (7a).

10 Embodiment 2. DUT interface device according to embodiment 1, wherein the divider/coupler component (4) is a high directivity power divider/coupler splitting a test signal on the main terminal over the first and second branch terminals.

Embodiment 3. DUT interface device according to embodiment 1 or 2, wherein the I/Q mixer (6) is arranged to generate an injection signal ( $b_{inj}$ ) which is coherently combined with a reflected signal (b) received on the DUT terminal (3).

15 Embodiment 4. DUT interface device according to embodiment 1, 2 or 3, wherein the I/Q mixer (6) is connected to the control input terminal (8).

Embodiment 5. DUT interface device according to any one of embodiments 1-4, wherein the variable gain amplifier (5) comprises a plurality of variable attenuators.

20 Embodiment 6. System for executing measurements on a device under test (DUT, 9) comprising a vector network analyser (11), at least one DUT interface device (1) according to any one of embodiments 1-5 connected to an associated measuring port of the vector network analyser (11), and

25 a control unit (12) connected to the vector network analyser (11) and to control input terminals (8) of associated ones of the at least one DUT interface device (1), wherein the control unit (12) is arranged to provide quadrature control signals ( $V_i$ ,  $V_Q$ ) for the associated at least one DUT interface device (1),

wherein the at least one DUT interface device (1) is connected directly to the device under test (DUT, 9).

30 Embodiment 7. System according to embodiment 6, wherein the control unit (12) comprises digital-to-analogue converters to provide quadrature control signals ( $V_i$ ,  $V_Q$ ) for each of the at least one DUT interface device (1).

Embodiment 8. System according to embodiment 7, wherein the vector network analyser (11) is connected to the control unit (12) using a synchronization interface for executing frequency sweeps.

35 Embodiment 9. System according to embodiment 8, wherein the synchronization interface comprises a control signal (TTL) and an acknowledgment return signal (ACK).

Embodiment 10. Method for using a system according to any one of embodiments 6-9, wherein the system comprises a DUT interface device (1) according to any one of embodiments 1-5  
40 connected to a first measuring port of the vector network analyser (11), comprising

calibrating the system by obtaining injection signal parameters to allow measurements of a device under test (9) connected to the DUT interface device (1).

Embodiment 11. Method according to embodiment 10, further comprising

- (a) perform a short-open-load calibration on the first measuring port of the vector network analyser (11) with the injection signal ( $b_{inj}$ ) off,
- (b) calculating  $50\Omega$  error terms,
- (c) connecting the device under test (9),
- (d) compute input reflection coefficient  $\Gamma_{in\_50}$  of the device under test (9) in a  $50\Omega$  environment and determine required quadrature control signals ( $V_I$ ,  $V_Q$ ) to minimize the input reflection coefficient  $\Gamma_{in\_50}$ .

Embodiment 12. Method according to embodiment 10, further comprising

- (a) connecting a high gamma load as device under test (9) to the first measuring port of the vector network analyser (11) via the first DUT interface device (1),
- (b) determine required quadrature control signals ( $V_I$ ,  $V_Q$ ) to minimize the reflection coefficients ( $\Gamma_{raw}$ ),
- (c) perform a short-open calibration on the first measuring port of vector network analyser (11) with the injection signal ( $b_{inj}$ ) on, and
- (d) compute system error terms ( $e_{00\_HG}$ ,  $e_{11\_HG}$ ,  $e_{10}e_{01\_HG}$ ) for the first measuring port of the vector network analyser (11).

- Embodiment 13. Method according to embodiment 11 or 12, wherein the system comprises a further DUT interface device (1) according to any one of embodiments 1-5, wherein the further DUT interface device (1) is connected to a second measuring port of the vector network analyser (11), the method further comprising repeating steps (a)-(d) for the second measuring port of the vector network analyser (11).

Embodiment 14. Method according to embodiment 10, further comprising,

- connecting a high gamma load as device under test (9) to the first and second measuring port of the vector network analyser (11) via the associated DUT interface devices (1),
- acquiring raw input reflection coefficients ( $\Gamma_{INraw}$ ) on the first measuring port of the vector network analyser (11) using the associated injection signal ( $b_{inj}$ ),
- acquiring raw output reflection coefficients ( $\Gamma_{OUTraw}$ ) on the second measuring port of the vector network analyser (11) using the associated injection signal ( $b_{inj}$ ),
- acquiring scattering parameters ( $S_{12raw}$ ,  $S_{21raw}$ ) with injection signals ( $b_{inj}$ ) to both measuring ports off,
- correcting the acquired parameters using the system error terms obtained from the calibration method step,
- obtaining normalized scattering parameters for the high gamma load as device under test (9).

Embodiment 15. Method according to any one of embodiments 10-14, wherein measurement of a device under test (DUT) is executed at a predetermined frequency with or without injection signals ( $b_{inj}$ ) in dependence of a sensitivity parameter ( $\Delta$ ), the sensitivity parameter ( $\Delta$ ) being defined as

the derivative of the magnitude of the reflection coefficient ( $\Gamma$ ) in respect of the magnitude of the load impedance ( $Z$ ).

Embodiment 16. Method according to any one of embodiments 10-15, wherein the high gamma load, in operation, has a high voltage standing wave ratio.

- 5 Embodiment 17. Method according to embodiment 16, wherein the voltage standing wave ratio is higher than 9.

The present invention has been described above with reference to a number of exemplary embodiments as shown in the drawings. Modifications and alternative implementations of some parts or elements are possible, and are included in the scope of protection as defined in the  
10 appended claims.

## Conclusies

1. Interface inrichting voor een te testen inrichting (DUT) voor het aansluiten van een vectornetwerkanalyse-inrichting (11) op een te testen inrichting (9), omvattende  
5 een analyse-inrichtingaansluiting (2), een DUT-aansluiting (3), en een besturingsingangaansluiting (8),  
een splitser/koppelcomponent (4) met een hoofdaansluiting die verbonden is met de analyse-inrichtingaansluiting (2),  
een versterker met variabele versterking (5) die verbonden is met een aansluiting van een eerste  
10 tak van de splitser/koppelcomponent (4),  
een I/Q mixer (6) met een ingangsaansluiting die verbonden is met een uitgangsaansluiting van de versterker met variabele versterking (5),  
een brug/koppelcomponent (7), waarvan aansluitingen van een eerste tak zijn verbonden tussen  
een aansluiting van een tweede tak van de splitser/koppelcomponent (4) en de DUT-aansluiting  
15 (3) voor het verschaffen van een testsignaal ( $a$ ) aan de DUT-aansluiting (3), en aansluitingen van een tweede tak zijn verbonden tussen een uitgang van de I/Q mixer (6) en een aardingsimpedantie (7a).
2. DUT-interface inrichting volgens conclusie 1, waarbij de splitser/koppelcomponent (4) een  
20 vermogenssplitser/koppeling is met een hoge gerichtheid die een testsignaal op de hoofdaansluiting splitst over de aansluitingen van een eerste tak en een tweede tak.
3. DUT-interface inrichting volgens conclusie 1 of 2, waarbij de I/Q mixer (6) is ingericht om  
een injectiesignaal ( $b_{inj}$ ) op te wekken dat coherent gecombineerd is met een gereflecteerd  
25 signaal ( $b$ ) dat ontvangen wordt op de DUT-aansluiting (3).
4. DUT-interface inrichting volgens conclusie 1, 2 of 3, waarbij de I/Q mixer (6) is verbonden met de besturingsingangaansluiting (8).
- 30 5. DUT-interface inrichting volgens één van de conclusies 1-4, waarbij de versterker met variabele versterking (5) een veelvoud variabele dempers omvat.
6. Systeem voor het uitvoeren van metingen op een te testen inrichting (DUT, 9) omvattende  
een vectornetwerkanalyse-inrichting (11), ten minste één DUT-interface inrichting (1) volgens één  
35 van de conclusies 1-5 die verbonden is met een bijbehorende meetpoort van de vectornetwerkanalyse-inrichting (11), en  
een besturingseenheid (12) die verbonden is met de vectornetwerkanalyse-inrichting (11) en met besturingsingangaansluitingen (8) van bijbehorende van de ten minste ene DUT-interface  
inrichting (1), waarbij de besturingseenheid (12) is ingericht om quadratuurbesturingssignalen ( $V_i$ ,  
40  $V_o$ ) op te wekken voor bijbehorende van de ten minste ene DUT-interface inrichting (1),

waarbij de ten minste ene DUT-interface inrichting (1) direct is verbonden met de te testen inrichting (DUT, 9).

7. Systeem volgens conclusie 6, waarbij de besturingseenheid (12) digitaal-naar-analoog omzeters omvat om quadratuurbesturingssignalen ( $V_i$ ,  $V_Q$ ) te verschaffen voor elk van de ten minste ene DUT-interface inrichting (1).

8. Systeem volgens conclusie 7, waarbij de vectornetwerkanalyse-inrichting (11) is verbonden met de besturingseenheid (12) met gebruik van een synchronisatie-interface voor het uitvoeren van frequentiezwaaien.

9. Systeem volgens conclusie 8, waarbij de synchronisatie-interface een besturingssignaal (TTL) en een bevestigingretoursignaal (ACK) omvat.

10. Werkwijze voor het gebruiken van een systeem volgens één van de conclusies 6-9, waarbij het systeem een DUT-interface inrichting (1) volgens één van de conclusies 1-5 omvat die verbonden is met een eerste meetpoort van de vectornetwerkanalyse-inrichting (11), omvattende kalibreren van het systeem door het verkrijgen van injectiesignaalparameters om metingen mogelijk te maken van een te testen inrichting (9) die verbonden is met de DUT-interface inrichting (1).

11. Werkwijze volgens conclusie 10, verder omvattende

- (a) uitvoeren van een 'short-open-load' kalibratie op de eerste meetpoort van de vectornetwerkanalyse-inrichting (11) met het injectiesignaal ( $b_{inj}$ ) uitgeschakeld,
- (b) berekenen van  $50\Omega$  fouttermen,
- (c) aansluiten van de te testen inrichting (9),
- (d) berekenen van ingang reflectiecoëfficiënten  $\Gamma_{in\_50}$  van de te testen inrichting (9) in een  $50\Omega$  omgeving en bepalen van vereiste quadratuurbesturingssignalen ( $V_i$ ,  $V_Q$ ) om de ingang reflectiecoëfficiënt  $\Gamma_{in\_50}$  te minimaliseren.

12. Werkwijze volgens conclusie 10, verder omvattende

- (a) aansluiten van een hoge-gammabelasting als te testen inrichting (9) op de eerste meetpoort van de vectornetwerkanalyse-inrichting (11) via de eerste DUT-interface inrichting (1),
- (b) bepalen van vereiste quadratuurbesturingssignalen ( $V_i$ ,  $V_Q$ ) om de reflectiecoëfficiënten ( $\Gamma_{raw}$ ) te minimaliseren,
- (c) uitvoeren van een 'short-open' kalibratie op de eerste meetpoort van de vectornetwerkanalyse-inrichting (11) met het injectiesignaal ( $b_{inj}$ ) ingeschakeld, en
- (d) berekenen van systeemfouttermen ( $e_{00\_HG}$ ,  $e_{11\_HG}$ ,  $e_{10}e_{01\_HG}$ ) voor de eerste meetpoort van de vectornetwerkanalyse-inrichting (11).

13. Werkwijze volgens conclusie 11 of 12, waarbij het systeem een verdere DUT-interface inrichting (1) omvat volgens één van de conclusies 1-5, waarbij de verdere DUT-interface inrichting (1) verbonden is met een tweede meetpoort van de vectornetwerkanalyse-inrichting (11),
- 5 waarbij de werkwijze verder omvat herhalen van stappen (a)-(d) voor de tweede meetpoort van de vectornetwerkanalyse-inrichting (11).
14. Werkwijze volgens conclusie 10, verder omvattende,
- 10 aansluiten van een hoge-gammabelasting als te testen inrichting (9) op de eerste en tweede meetpoort van de vectornetwerkanalyse-inrichting (11) via de bijbehorende DUT-interface inrichtingen (1),
- verkrijgen van ruwe ingang reflectiecoëfficiënten ( $\Gamma_{INraw}$ ) op de eerste meetpoort van de vectornetwerkanalyse-inrichting (11) met gebruik van het bijbehorende injectiesignaal ( $b_{inj}$ ),
- 15 verkrijgen van ruwe uitgang reflectiecoëfficiënten ( $\Gamma_{OUTraw}$ ) op de tweede meetpoort van de vectornetwerkanalyse-inrichting (11) met gebruik van het bijbehorende injectiesignaal ( $b_{inj}$ ),
- verkrijgen van strooiingsparameters ( $S_{12raw}$ ,  $S_{21raw}$ ) met injectiesignalen ( $b_{inj}$ ) op beide meetpoorten uitgeschakeld,
- corrigeren van de verkregen parameters met gebruik van de systeemfouttermen die verkregen zijn met de kalibratiewerkwijzestap,
- 20 verkrijgen van genormaliseerde strooiingsparameters voor de hoge-gammabelasting als te testen inrichting (9).
15. Werkwijze volgens één van de conclusies 10-14, waarbij meting van een te testen inrichting (DUT) wordt uitgevoerd bij een vooraf bepaalde frequentie met of zonder injectiesignalen ( $b_{inj}$ ) afhankelijk van een gevoeligheidsparameter ( $\Delta$ ), waarbij de gevoeligheidsparameter ( $\Delta$ ) gedefinieerd is als de afgeleide van de grootte van de reflectiecoëfficiënt ( $\Gamma$ ) met betrekking tot de grootte van de belasting impedantie ( $Z$ ).
- 25
- 30 16. Werkwijze volgens één van de conclusies 10-15, waarbij de hoge-gammabelasting, tijdens bedrijf, een hoge spanning-staandegolfverhouding heeft.
17. Werkwijze volgens conclusie 16, waarbij spanning-staandegolfverhouding groter is dan 9.

\*\*\*\*\*

Fig. 1

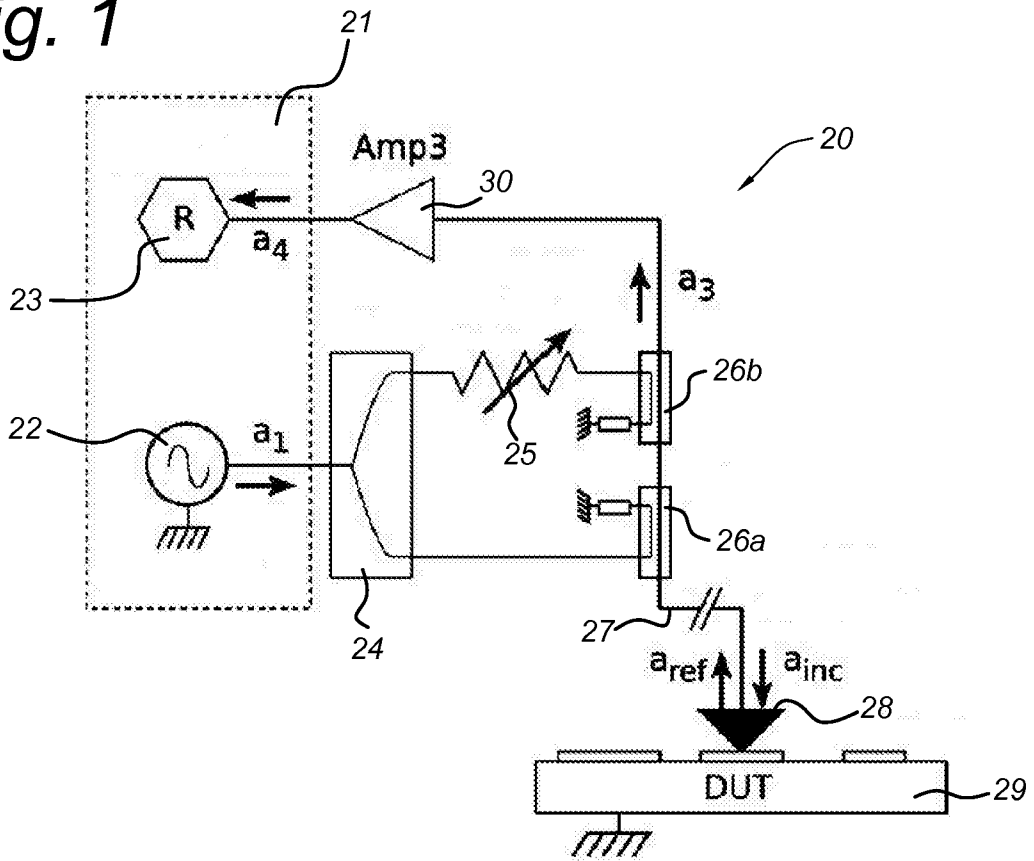

Fig. 2

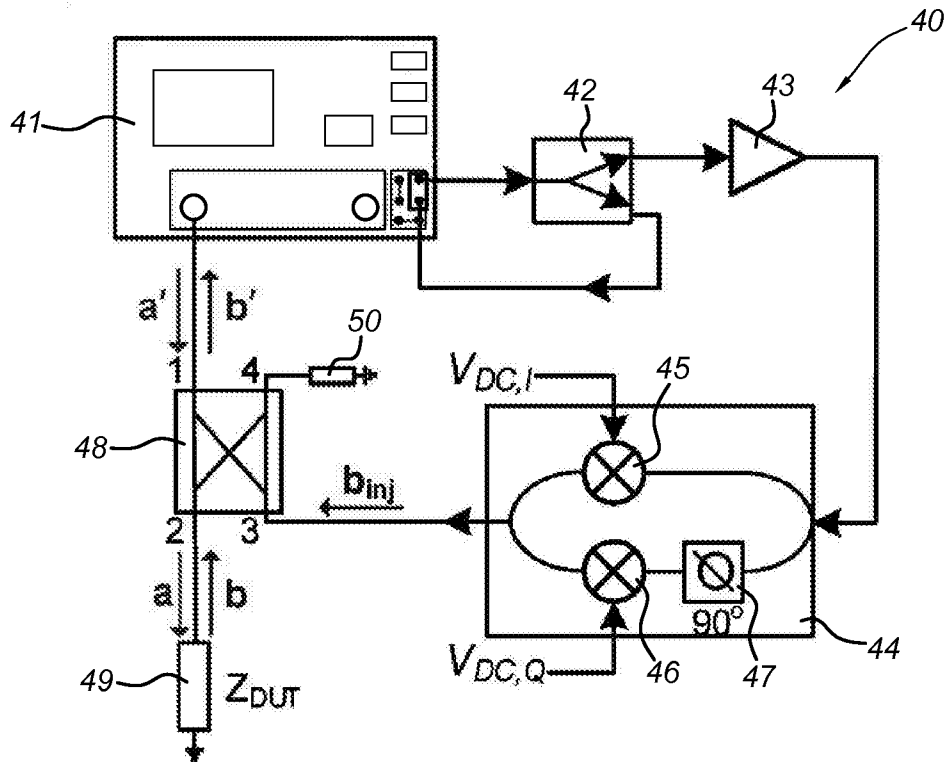

Fig. 3

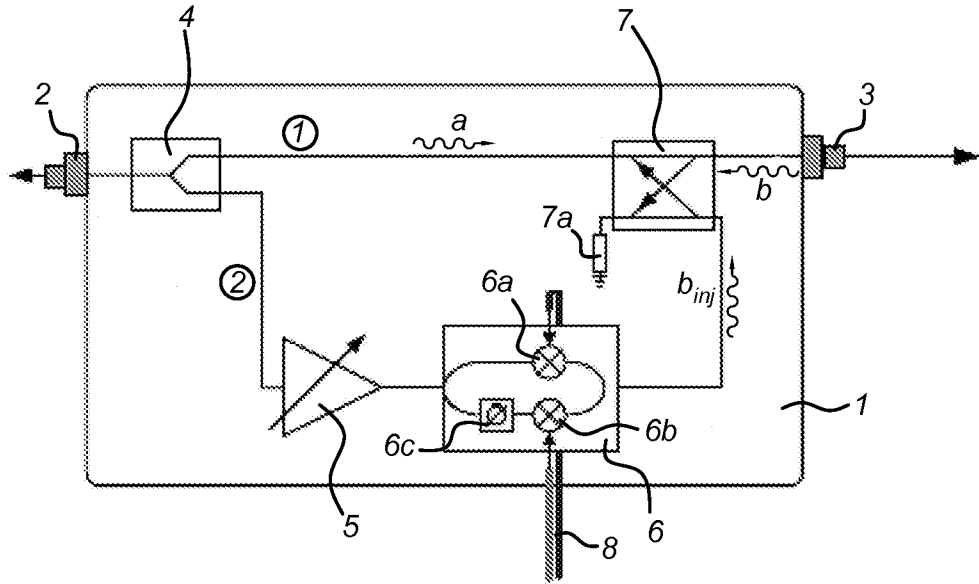
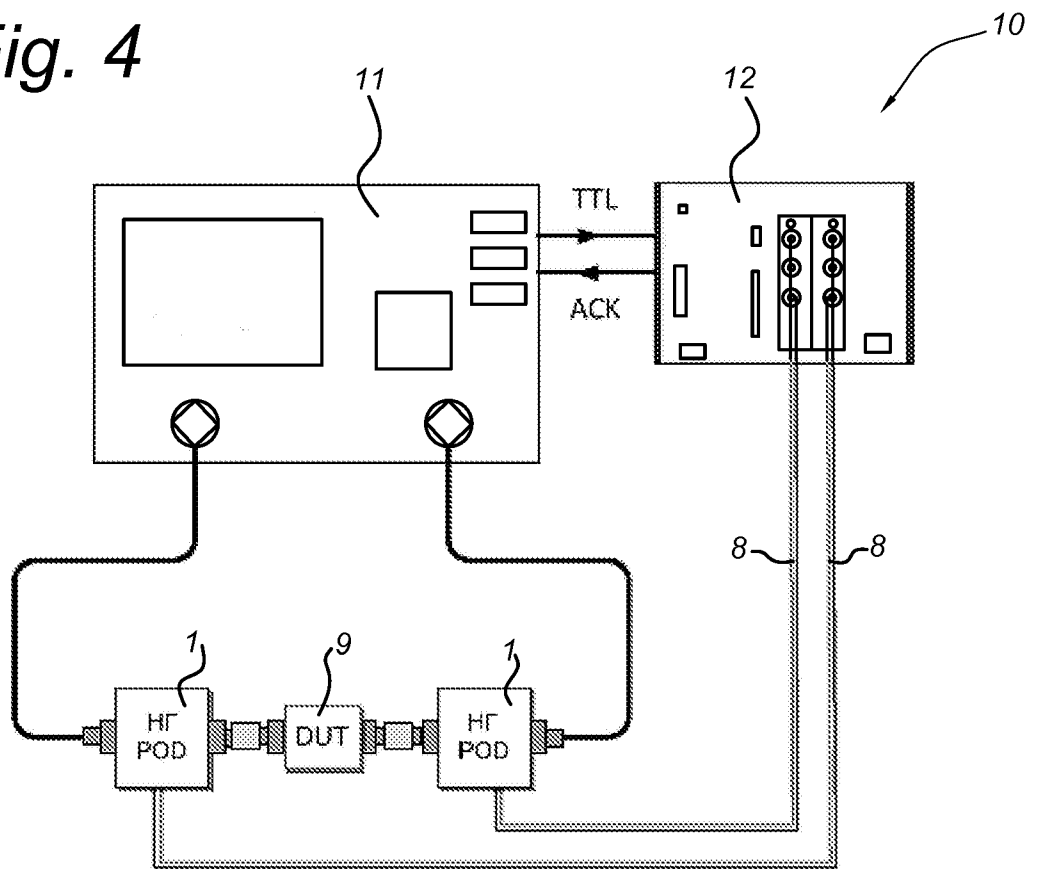
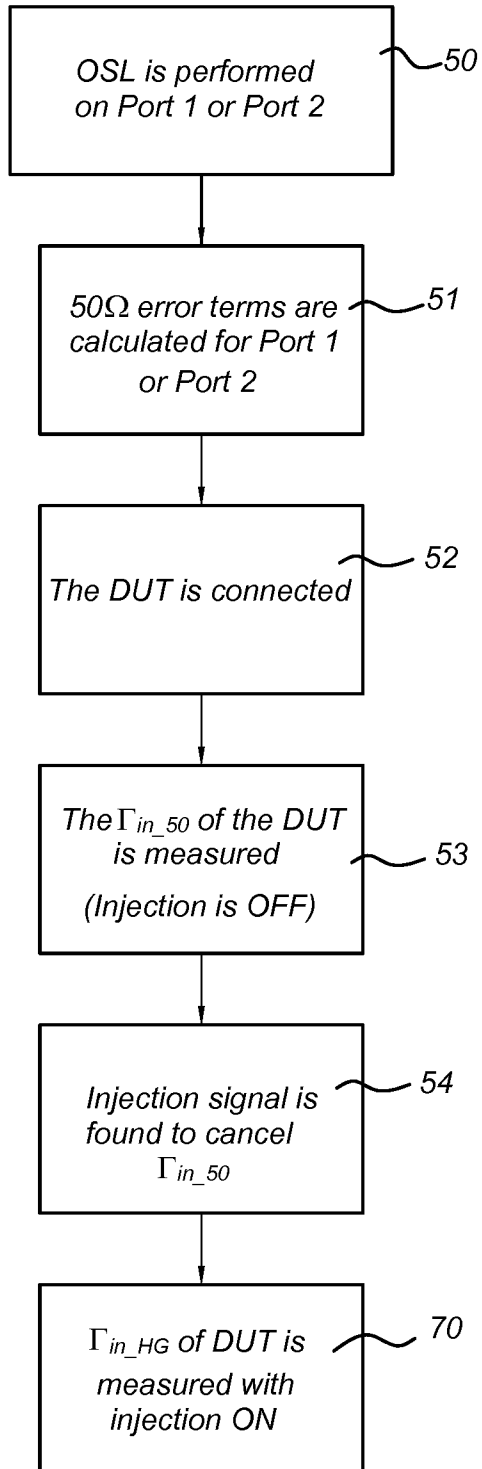

Fig. 4



*Fig. 5A*



*Fig. 5B*

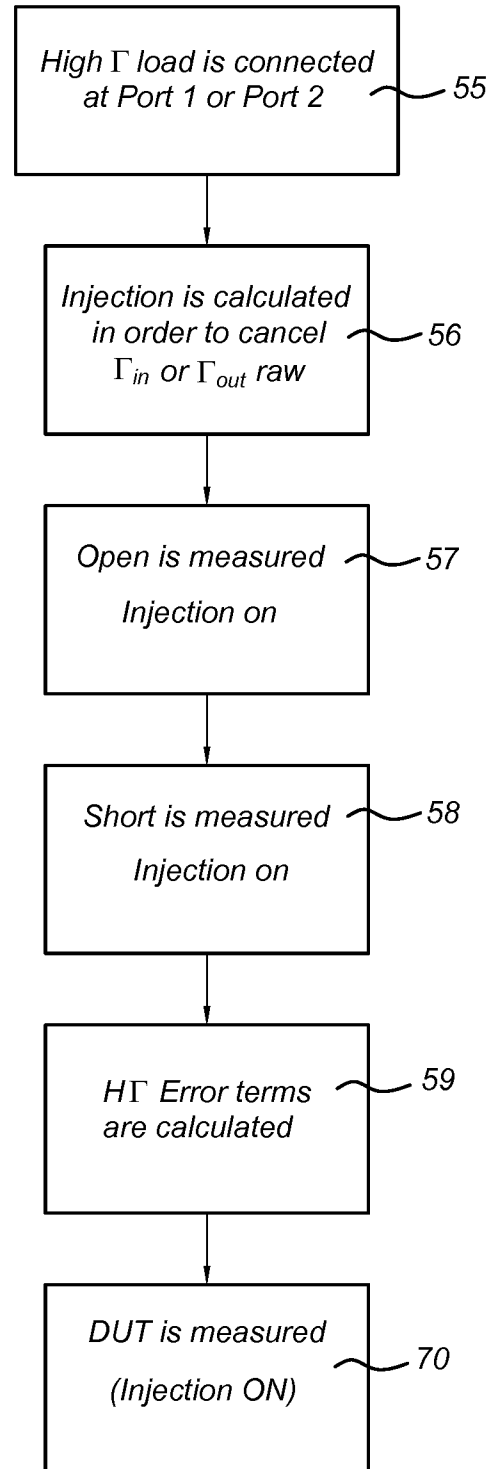

*Fig. 5c*

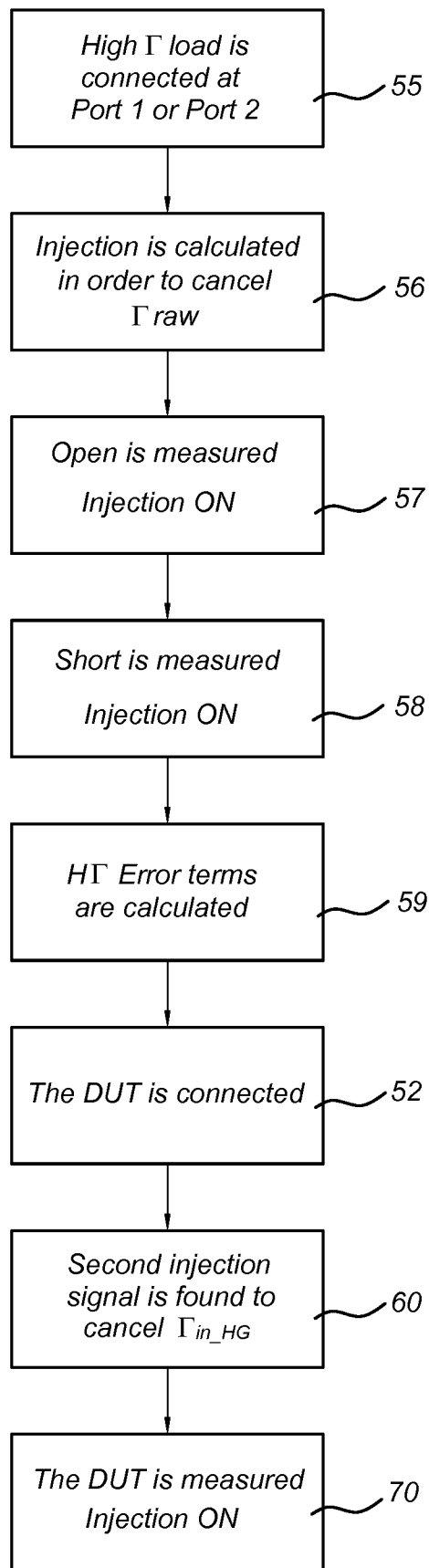

*Fig. 6*

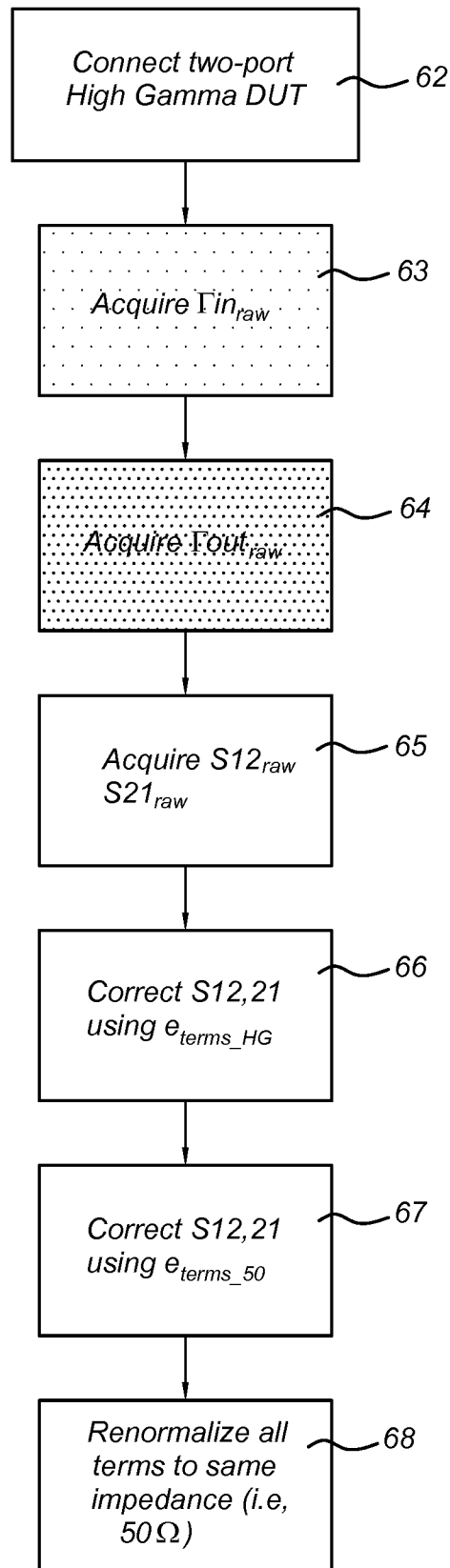

**Abstract**

Device under test (DUT) interface device for use in a system for executing measurements on a device under test (9) with a vector network analyser (11).

5 The DUT interface device comprises a divider/coupler component (4), a variable gain amplifier (5), an I/Q mixer (6) and a bridge/coupler component (7) and provides a test signal (a) to the DUT terminal (3).

The system further comprises a control unit (12) connected to the vector network analyser (11) and to control input terminals (8) of associated ones of the at least one DUT interface device (1).

10 The control unit (12) provides quadrature control signals ( $V_i$ ,  $V_Q$ ) for the associated at least one DUT interface device (1), which are connected directly to the device under test (9).

The present invention further relates to proper calibration and measurement methods.

[Fig. 4]

## SAMENWERKINGSVERDRAG (PCT)

### RAPPORT BETREFFENDE NIEUWHEIDSONDERZOEK VAN INTERNATIONAAL TYPE

IDENTIFICATIE VAN DE NATIONALE AANVRAGE	KENMERK VAN DE AANVRAGER OF VAN DE GEMACHTIGDE
	<b>P6062563NL</b>
Nederlands aanvraag nr.	Indieningsdatum
<b>2018225</b>	<b>25-01-2017</b>
	Ingeroepen voorrangsdatum
Aanvrager (Naam)	
<b>Technische Universiteit Delft</b>	
Datum van het verzoek voor een onderzoek van internationaal type	Door de Instantie voor Internationaal Onderzoek aan het verzoek voor een onderzoek van internationaal type toegekend nr.
<b>01-04-2017</b>	<b>SN68667</b>
<b>I. CLASSIFICATIE VAN HET ONDERWERP</b> (bij toepassing van verschillende classificaties, alle classificatiesymbolen opgeven)	
Volgens de internationale classificatie (IPC)	
<b>G01R27/28;G01R35/00;G01R31/28</b>	
<b>II. ONDERZOCHE GEBIEDEN VAN DE TECHNIEK</b>	
Onderzochte minimumdocumentatie	
Classificatiesysteem	Classificatiesymbolen
<b>IPC</b>	<b>G01R</b>
Onderzochte andere documentatie dan de minimum documentatie, voor zover dergelijke documenten in de onderzochte gebieden zijn opgenomen.	
<b>III.</b>	<b>GEEN ONDERZOEK MOGELIJK VOOR BEPAALDE CONCLUSIES</b> (opmerkingen op aanvullingsblad)
<b>IV.</b>	<b>GEBREK AAN EENHEID VAN UITVINDING</b> (opmerkingen op aanvullingsblad)

**ONDERZOEKSRAPPORT BETREFFENDE HET  
RESULTAAT VAN HET ONDERZOEK NAAR DE STAND  
VAN DE TECHNIEK VAN HET INTERNATIONALE TYPE**

Nummer van het verzoek om een onderzoek naar  
de stand van de techniek

NL 2018225

<p>A. CLASSIFICATIE VAN HET ONDERWERP INV. G01R27/28 G01R35/00 G01R31/28 ADD.</p>		
<p>Volgens de Internationale Classificatie van octrooien (IPC) of zowel volgens de nationale classificatie als volgens de IPC.</p>		
<p>B. ONDERZOCHETE GEBIEDEN VAN DE TECHNIEK</p> <p>Onderzochte minimum documentatie (classificatie gevolgd door classificatiesymbolen) G01R</p>		
<p>Onderzochte andere documentatie dan de minimum documentatie, voor dergelijke documenten, voor zover dergelijke documenten in de onderzochte gebieden zijn opgenomen</p>		
<p>Tijdens het onderzoek geraadpleegde elektronische gegevensbestanden (naam van de gegevensbestanden en, waar uitvoerbaar, gebruikte trefwoorden)</p> <p>EPO-Internal, WPI Data</p>		
<p>C. VAN BELANG GEACHTE DOCUMENTEN</p>		
<p>Categorie "</p>	<p>Geciteerde documenten, eventueel met aanduiding van speciaal van belang zijnde passages</p>	<p>Van belang voor conclusie nr.</p>
<p>X</p>	<p>MUBARAK FAISAL ET AL: "Evaluation and modeling of measurement resolution of a vector network analyzer for extreme impedance measurements", 2015 86TH ARFTG MICROWAVE MEASUREMENT CONFERENCE, IEEE, 3 december 2015 (2015-12-03), bladzijden 1-3, XP032849340, DOI: 10.1109/ARFTG.2015.7381475 [gevonden op 2016-01-12] * alinea [000I] - alinea [001I]; figuur 1 *  ----- -/--</p>	<p>1-17</p>
<p><input checked="" type="checkbox"/> Verdere documenten worden vermeld in het vervolg van vak C. <input type="checkbox"/> Leden van dezelfde octrooifamilie zijn vermeld in een bijlage</p>		
<p>* Speciale categorieën van aangehaalde documenten</p> <p>"A" niet tot de categorie X of Y behorende literatuur die de stand van de techniek beschrijft</p> <p>"D" in de octrooiaanvraag vermeld</p> <p>"E" eerdere octrooi(aanvraag), gepubliceerd op of na de indieningsdatum, waarin dezelfde uitvinding wordt beschreven</p> <p>"L" om andere redenen vermelde literatuur</p> <p>"O" niet-schriftelijke stand van de techniek</p> <p>"P" tussen de voorrangsdatum en de indieningsdatum gepubliceerde literatuur</p> <p>"T" na de indieningsdatum of de voorrangsdatum gepubliceerde literatuur die niet bezwarend is voor de octrooiaanvraag, maar wordt vermeld ter verheldering van de theorie of het principe dat ten grondslag ligt aan de uitvinding</p> <p>"X" de conclusie wordt als niet nieuw of niet inventief beschouwd ten opzichte van deze literatuur</p> <p>"Y" de conclusie wordt als niet inventief beschouwd ten opzichte van de combinatie van deze literatuur met andere geciteerde literatuur van dezelfde categorie, waarbij de combinatie voor de vakman voor de hand liggend wordt geacht</p> <p>"Z" lid van dezelfde octrooifamilie of overeenkomstige octrooipublicatie</p>		
<p>Datum waarop het onderzoek naar de stand van de techniek van internationaal type werd voltooid</p> <p>22 september 2017</p>		<p>Verzenddatum van het rapport van het onderzoek naar de stand van de techniek van internationaal type</p>
<p>Naam en adres van de instantie</p> <p>European Patent Office, P.B. 5818 Patentlaan 2 NL - 2280 HV Rijswijk Tel. (+31-70) 340-2040, Fax: (+31-70) 340-3016</p>		<p>De bevoegde ambtenaar</p> <p>Maric, Viktor</p>

**ONDERZOEKSRAPPORT BETREFFENDE HET  
RESULTAAT VAN HET ONDERZOEK NAAR DE STAND  
VAN DE TECHNIEK VAN HET INTERNATIONALE TYPE**

Nummer van het verzoek om een onderzoek naar  
de stand van de techniek

NL 2018225

C.(Vervolg). VAN BELANG GEACHTE DOCUMENTEN		
Categorie *	Geciteerde documenten, eventueel met aanduiding van speciaal van belang zijnde passages	Van belang voor conclusie nr.
A,D	<p>Gerasimos Vlachogimmakis ET AL: "An I/Q-Mixer-Steering Interferometric Technique for High- Sensitivity Measurement of Extreme Impedances", 17 mei 2015 (2015-05-17), XP055397231, Gevonden op het Internet: URL:<a href="http://ieeexplore.ieee.org/ielx7/7155722/7166703/07166830.pdf?tp=&amp;arnumber=7166830&amp;isnumber=7166703">http://ieeexplore.ieee.org/ielx7/7155722/7166703/07166830.pdf?tp=&amp;arnumber=7166830&amp;isnumber=7166703</a> [gevonden op 2017-08-09] in de aanvraag genoemd * samenvatting; figuren 1-2 * * alinea [0001] - alinea [0011] *</p>	1-17
A	<p>KAMEL HADDADI ET AL: "Interferometric technique for microwave measurement of high impedances", MICROWAVE SYMPOSIUM DIGEST (MTT), 2012 IEEE MTT-S INTERNATIONAL, IEEE, 17 juni 2012 (2012-06-17), bladzijden 1-3, XP032217070, DOI: 10.1109/MWSYM.2012.6259554 ISBN: 978-1-4673-1085-7 * alinea [0001] - alinea [0111]; figuren 1-2 *</p>	1-17

## WRITTEN OPINION

File No. SN68667	Filing date (day/month/year) 25.01.2017	Priority date (day/month/year)	Application No. NL2018225
International Patent Classification (IPC) INV. G01R27/28 G01R35/00 G01R31/28			
Applicant Technische Universiteit Delft			

This opinion contains indications relating to the following items:

- Box No. I Basis of the opinion
- Box No. II Priority
- Box No. III Non-establishment of opinion with regard to novelty, inventive step and industrial applicability
- Box No. IV Lack of unity of invention
- Box No. V Reasoned statement with regard to novelty, inventive step or industrial applicability; citations and explanations supporting such statement
- Box No. VI Certain documents cited
- Box No. VII Certain defects in the application
- Box No. VIII Certain observations on the application

Examiner Maric, Viktor
---------------------------

## WRITTEN OPINION

Application number  
NL2018225

---

### Box No. I Basis of this opinion

---

1. This opinion has been established on the basis of the latest set of claims filed before the start of the search.
2. With regard to any **nucleotide and/or amino acid sequence** disclosed in the application and necessary to the claimed invention, this opinion has been established on the basis of:
  - a. type of material:
    - a sequence listing
    - table(s) related to the sequence listing
  - b. format of material:
    - on paper
    - in electronic form
  - c. time of filing/furnishing:
    - contained in the application as filed.
    - filed together with the application in electronic form.
    - furnished subsequently for the purposes of search.
3.  In addition, in the case that more than one version or copy of a sequence listing and/or table relating thereto has been filed or furnished, the required statements that the information in the subsequent or additional copies is identical to that in the application as filed or does not go beyond the application as filed, as appropriate, were furnished.
4. Additional comments:

---

### Box No. V Reasoned statement with regard to novelty, inventive step or industrial applicability; citations and explanations supporting such statement

---

1. Statement

Novelty	Yes: Claims	2-17
	No: Claims	1
Inventive step	Yes: Claims	
	No: Claims	1-17
Industrial applicability	Yes: Claims	1-17
	No: Claims	
2. Citations and explanations  
**see separate sheet**

**WRITTEN OPINION**

Application number  
NL2018225

---

---

**Box No. VII Certain defects in the application**

---

see separate sheet

1 **Re Item V**

**Reasoned statement with regard to novelty, inventive step or industrial applicability; citations and explanations supporting such statement**

1.1 Reference is made to the following documents:

- D1 MUBARAK FAISAL ET AL: "Evaluation and modeling of measurement resolution of a vector network analyzer for extreme impedance measurements",  
2015 86TH ARFTG MICROWAVE MEASUREMENT CONFERENCE, IEEE, 3 december 2015 (2015-12-03),  
bladzijden 1-3, XP032849340,  
DOI: 10.1109/ARFTG.2015.7381475  
[gevonden op 2016-01-12]
- D2 Gerasimos Vlachogimmakis ET AL: "An I/Q-Mixer-Steering Interferometric Technique for High Sensitivity Measurement of Extreme Impedances",  
17 mei 2015 (2015-05-17), XP055397231,  
Gevonden op het Internet:  
URL:<http://ieeexplore.ieee.org/ielx7/7155722/7166703/07166830.pdf?tp=&arnumber=7166830&isnumber=7166703>  
[gevonden op 2017-08-09]  
in de aanvraag genoemd
- D3 KAMEL HADDADI ET AL: "Interferometric technique for microwave measurement of high impedances",  
MICROWAVE SYMPOSIUM DIGEST (MTT), 2012 IEEE MTT-S INTERNATIONAL, IEEE, 17 juni 2012 (2012-06-17), bladzijden 1-3, XP032217070,  
DOI: 10.1109/MWSYM.2012.6259554  
ISBN: 978-1-4673-1085-7

1.2 The present application does not meet the criteria of patentability, because the subject-matter of claim 1 is not new.

1.3 **D1 (Fig.1)** is regarded as being the prior art closest to the subject-matter of claim 1, and discloses:

a device under test interface device (**Fig.1**) for connecting a vector network analyser ( $\omega_{rt}$ ) to a device under test (**implicit for Ref.**), comprising an analyser terminal (**implicitly present between  $\omega_{rt}$  and power splitter**), a DUT terminal (**implicitly present between inj. coupler and Ref.**), and a control input terminal ( $V_i, V_o$ ), a divider/coupler component (**power splitter**) having a main terminal connected to the analyser terminal (**terminal between  $\omega_{rt}$  and power splitter**), a variable gain amplifier (**amplifier**) connected to a first branch terminal of the divider/coupler component (**power splitter**), an I/Q mixer (**IQ mixer**) having an input terminal connected to an output terminal of the variable gain amplifier (**amplifier**), a bridge/coupler component (**inj. coupler**), of which first branch terminals are connected between a second branch terminal of the divider/coupler component (**splitter**) and the DUT terminal (**Ref.**) for providing a test signal (**a**) to the DUT terminal (**Ref.**), and second branch terminals are connected between an output of the I/Q mixer (**IQ mixer**) and a grounding impedance (**implicitly present, since analogous to Figure 1 of the applicant's prior art, XP055397231**).

- 1.4 The same reasoning applies, mutatis mutandis, to the subject-matter of the corresponding features of the independent method claim **10**, and since the calibration of the system by obtaining injection signal parameters is considered to represent standard practice of a skilled person, the independent method claim **10** is considered not inventive.
- 1.5 Dependent claims **2-9** and **11-17** do not contain any features which, in combination with the features of any claim to which they refer, meet the requirements of novelty and/or inventive step, since the added features are either disclosed or rendered obvious by the above citations or come within the scope of conventional practice followed by the skilled person.

## 2 Re Item VII

### **Certain defects in the application**

- 2.1 Independent claim **1** is not in the two-part form, which in the present case would be appropriate, with those features known in combination from the prior art being placed in the preamble and the remaining features being included in the characterising part.
- 2.2 The relevant background art disclosed in **D1** is not mentioned in the description, nor is this document identified therein.