

[54] **CRUCIBLE-FREE ZONE MELTING
DEVICE HAVING AN ANGLED
HEATING COIL**

3,477,811 11/1969 Keller.....23/301
3,539,305 11/1970 Keller.....23/301
3,607,109 9/1971 Capita.....23/301

[76] Inventors: **Otto Schmidt**, Erlangen, Germany;
Siemens Aktiengesellschaft, 03, Ber-
lin and Munich, Germany

FOREIGN PATENTS OR APPLICATIONS

1,482,659 4/1967 France.....23/301

[22] Filed: **Nov. 30, 1970**

Primary Examiner—Norman Yudkoff
Assistant Examiner—R. T. Foster
Attorney—Curt M. Avery, Arthur E. Wilfond, Herbert
L. Lerner and Daniel J. Tick

[21] Appl. No.: **93,650**

[30] **Foreign Application Priority Data**

Nov. 29, 1969 Germany.....P 19 60 088.5

[52] **U.S. Cl.**.....23/273 SP, 23/301 SP

[51] **Int. Cl.**.....B01j 17/10

[58] **Field of Search**.....23/301 SP, 273 SP

[57] **ABSTRACT**

Device for crucible-free zone melting a crystalline rod end-supported by holders of which one holder is rotatable about the longitudinal axis thereof includes a flat induction heating coil surrounding the longitudinal axis of the other holder for heating a molten zone formed in the crystalline rod, the induction heating coil having a plurality of windings disposed in a single plane, the plane extending at an acute angle defined by a normal to said plane of said windings and the longitudinal axes of both rod holders having a valve within the range of 0.5° to 3°.

[56] **References Cited**

UNITED STATES PATENTS

2,898,429 8/1959 Emeis et al.....23/273
3,117,859 1/1964 Chandrasekhar.....23/301
3,159,459 12/1964 Keller.....23/301
3,260,573 7/1966 Ziegler.....23/301
3,271,115 9/1966 Keller.....23/301

3 Claims, 4 Drawing Figures

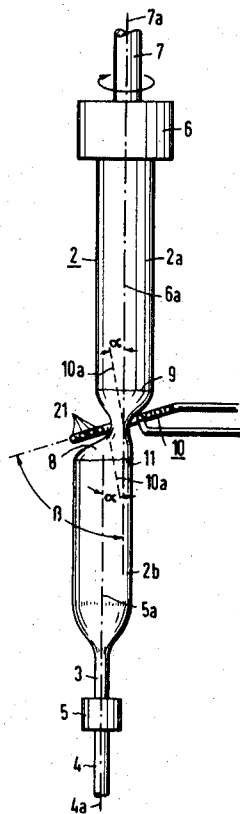

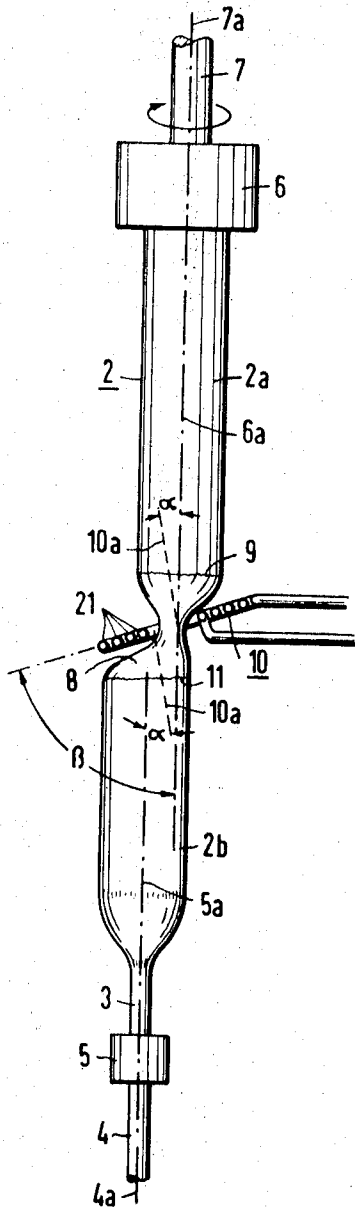

Fig. 1

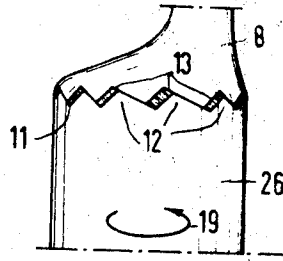

Fig. 2

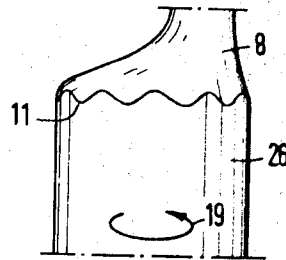

Fig. 3

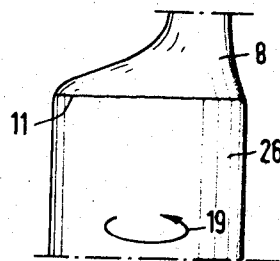

Fig. 4

CRUCIBLE-FREE ZONE MELTING DEVICE HAVING AN ANGLED HEATING COIL

The invention relates to device for crucible-free zone melting a crystalline rod which is end-supported by holders of which one holder is rotatable about the longitudinal axis thereof, and which includes an induction heating coil surrounding the longitudinal axis of the rotatable holder for heating a melting zone formed in the crystalline rod, the windings of the induction heating coil being disposed in a single plane; and method for operating this device.

There are disclosed in application Ser. No. 853,596 of W. Keller et al., filed Aug. 19, 1969, that application being assigned to the same assignee as the assignee of the instant application, and in U.S. Pat. No. 3,447,811 of W. Keller, methods and devices for crucible-free zone melting a crystalline rod with a flat induction heating coil whose windings are disposed in a single plane. By means of relative motion between the vertically disposed rod and the induction heating coil surrounding this rod in direction of the longitudinal axis of the crystalline rod, a molten zone is passed through the crystalline rod starting from the location at which a monocrystalline seed crystal is fused to the lower end of the crystalline rod.

In this disclosure of heretofore known art, the rod holder which supports the rod portion that is to be zone melted is rotated about the longitudinal axis thereof. By means of the crucible-free zone melting operation which is carried out, the crystalline rod is transformed into a monocrystal, and specific impurities are removed therefrom. A flat induction heating coil having windings that are disposed in a single plane has the advantage that it produces a relatively short or narrow molten zone in the crystalline rod. This reduces the danger of the dripping of molten material from the molten zone, especially in the case where relatively thick crystalline rods are being zone melted by a crucible-free method.

According to the afore-mentioned copending application this danger can be further reduced if the inner diameter of the flat induction heating coil is smaller than the diameter of the starting rod which is to be zone melted, and when the seed crystal after the molten zone is produced at the location of melting on the crystalline rod and before the molten zone is passed through the crystalline rod, is displaced laterally into a new starting position. In this case, a narrowed down molten zone with relatively little liquid melt is formed.

According to the afore-mentioned patent, the thickness of the rod portion recrystallized out of the melt is increased beyond the inner diameter of the heating device, due to the fact that the holder for the seed crystal with the recrystallized rod portion is rotated about the longitudinal axis thereof after the molten zone is produced at the location at which the seed crystal is fused to the crystalline rod; that holder is then laterally displaced into a new starting position and, during the molten zone pass through the crystalline rod is laterally reciprocated successively about this new starting position. A recrystallized rod produced in this manner can have a relatively large diameter and is marked by an especially uniform impurity concentration.

When producing an especially thick monocrystalline rod by crucible-free zone melting with a flat induction

heating coil whose windings are disposed in a plane extending perpendicularly to the longitudinal axes of the rod holders and thereby to the longitudinal axis of the crystalline rod, periodic solidifying and remelting of the material at the recrystallization front with the recrystallized large portion are effected due to the nonuniform distribution of the field emanating from the flat coil. This manifestation is especially marked when the longitudinal axis of the rod holder for the seed crystal with the recrystallized portion and therewith the longitudinal axis of the recrystallized rod portion is laterally offset with respect to the longitudinal axes of the crystalline rod and the rod holder in which this rod is secured during the zone melting pass through the crystalline rod. This periodic solidification or hardening and remelting of the material at the recrystallization front of the monocrystalline recrystallized rod portion is the cause for the formation of dislocations in this rod portion.

It is accordingly an object of the invention to provide device for crucible-free zone melting a crystalline rod and a method of operating the same so as to produce very thick rod-shaped monocrystals with greatly improved crystal quality by a crucible-free zone melting operation, employing a flat induction heating coil.

With the foregoing and other objects in view I provide in accordance with the invention, in device for crucible-free zone melting a crystalline rod end-supported by holders of which one holder is rotatable about the longitudinal axis thereof, a flat induction heating coil surrounding the longitudinal axis of the other holder for heating a molten zone formed in the crystalline rod, the induction heating coil having a plurality of windings disposed in a single plane, the plane extending at an angle inclined to the longitudinal axes of both rod end holders; and method of operating the device. This means that the normals to the planes in which the windings of the induction heating coil are disposed define with the longitudinal axes of the rod holders an acute angle of varying dimensions from 0°.

It is advantageous if this acute angle is at least 0.4°.

In accordance with another feature of the invention, the normals to the plane in which the induction coil windings are disposed define an angle with the longitudinal axis of the rod holder, that is within the range of from 0.5° to 3°, preferably of 1°-1.5°.

In accordance with a further feature of the invention, the rod holder that is rotatable about the longitudinal axis thereof is laterally displaceable.

Due to the inclined orientation of the flat induction heating coil with respect to the longitudinal axes of the rod holders, the rate of growth of the monocrystalline recrystallized rod portion is adjusted or made uniform and therefore the crystal quality thereof is improved.

In accordance with still another feature of the invention, the rod end at which the recrystallized rod portion is formed, is secured in the holder that is rotatable about the longitudinal axis thereof and this holder is set into rotation about the longitudinal axis thereof after the molten zone is produced. Advantageously, the holder can then be laterally displaced into a new starting position within an acute angle which is defined by the plane in which the windings of the flat induction heating coil are disposed with the longitudinal axis of the other holder for the rod portion that is to be melted,

at the side of the plane in which the induction coil windings are disposed which faces the rotary holder with the recrystallized rod portion.

Other features which are considered as characteristic for the invention are set forth in the appended claims.

Although the invention is illustrated and described herein as device for crucible free zone melting a crystalline rod and a method of operating the same, it is nevertheless not intended to be limited to the details shown, since various modifications may be made therein without departing from the spirit of the invention and within the scope and range of equivalents of the claims.

The invention, however, together with additional objects and advantages thereof will be best understood from the following description when read in connection with the accompanying drawings, in which:

FIG. 1 is an axial view of the device for crucible free zone melting of crystalline rod in accordance with the invention; and

FIGS. 2-4 are much enlarged fragmentary views of rod portions recrystallized by crucible free zone melting showing the edge of the recrystallization fronts thereof.

Referring now to the drawings and first particularly to FIG. 1 thereof, there is shown a device for crucible free zone melting which includes rod end holders 5 and 6 carried by respective drive shafts 4 and 7 having parallel, vertically extending longitudinal axes 4a and 7a, respectively. The shafts 4 and 7 with the holders 5 and 6, respectively, are disposed in a nonillustrated receptacle that is either evacuated or filled with protective gas, such as nitrogen or argon. The shafts 4 and 7 extend through nonillustrated openings formed in the walls of the receptacle and are sealed therein by suitable grommets (not shown). Both the shafts 4 and 7 are rotatable about their longitudinal axes and are mounted so as to be displaceable in the axial directions thereof. The shaft 4 with the rod holder 5 mounted thereon is furthermore laterally displaceable, i.e., transversely or in fact perpendicularly to the longitudinal axis 4a and to the longitudinal axis 5a of the holder 5. The longitudinal axis 6a of the holder 6 is aligned with the longitudinal axis 7a, while the longitudinal axis 5a of the holder 5 is aligned with the longitudinal axis 4a.

The device shown in FIG. 1 is provided furthermore with a flat induction heating coil 10 which surrounds the longitudinal axis 6a of the upper rod holder 6. The windings 21 of the induction heating coil 10 are disposed in a single plane. The plane in which the windings 21 are disposed extends at an angle inclined to the longitudinal axes 5a and 6a of the holders 5 and 6, respectively, i.e., the normals 10a thereto form an acute angle α with the longitudinal axes 5a and 6a, respectively. The induction heating coil 10 is energized with a high frequency alternating current by a nonillustrated high frequency generator.

A silicon rod 2 having a seed crystal 3 fused to the lower end thereof is vertically secured in the holders 5 and 6. The rod portion 2a that is to be zone melted is clamped in the upper rotatable holder 6 while the monocrystalline seed crystal 3 with the recrystallized rod portion 2b fused thereto is secured in the holder 5, which may also be rotatable. A molten zone 8 is ini-

tially produced with the aid of the induction heating coil 10 at the fusing location of the seed crystal 3 to the silicon rod 2. Thereafter, the rod holders 5 and 6, whose longitudinal axes 5a and 6a, respectively, are initially aligned, are set into rotation about the longitudinal axes thereof in opposite rotary directions. Then, the lower rod holder 5 is laterally displaced into a new starting position within an acute angle β which is formed by the intersection of the longitudinal axis 6a of the holder 6 with the plane in which the windings 21a of the induction heating coil 10 are disposed at the side of the plane of the windings 22 which faces the holder 5. The new starting position of the rod holder 5 is advantageously selected so that the longitudinal axis 5a is disposed within the plane which coincides with the area defined by the acute angle α located between the normals 10a of the plane in which the windings 21a are located and the longitudinal axis 6a of the holder 6 for the rod portion 2a that is to be zone melted, i.e., the plane of the acute angle α being coincident with the plane of the drawing of FIG. 1. During the lateral displacement of the lower rod holder 5, the holder 6 with the rod portions 2a that is to be zone melted is moved slightly toward the induction heating coil 10. By means of relative motion between the rod holders 5 and 6, on the one hand, and the induction heating coil 10, on the other hand, for example by displacing the rod holders downwardly from above while the induction heating coil is held stationary, the molten zone 8 is then passed through the silicon rod 2 starting from the location at which the seed crystal 2 is fused to the rod portion 2b, as the rod holders are offset laterally from one another. Since the inner diameter of the induction heating coil 10 is smaller than the diameter of the rod portion 2a which is to be zone melted, the molten zone 8 is narrowed down. FIG. 1 shows one stage in the course of a molten zone pass through the crystalline or semiconductor rod 2.

FIGS. 2-4 illustrate the effect of a flat induction heating coil disposed at an angle inclined to the longitudinal axes of the rod holders. In these figures there is provided a view of a stage in the formation of the recrystallization front between the molten zone and the recrystallized rod portion in the course of a crucible free zone melting operation performed on a crystalline rod with a flat induction heating coil wherein the holder for the recrystallized rod portion is laterally offset.

FIG. 2 shows the recrystallization front 11 when the plane in which the flat induction heating coil is disposed extends perpendicularly to the longitudinal axes of the rod holders and thereby also perpendicularly to the longitudinal axes of both rod portions. As can be seen, the recrystallization front 11 has saw teeth-like serrations 12 extending into the liquid melt of the molten zone 8. During the rotation of the recrystallized rod portion 2b about the longitudinal axis thereof in the direction of the arrow 19, the material at one flank or side of the tooth-like serrations 12 periodically melts and hardens so that the uniform speed of crystal growth is disturbed, which causes dislocations in the recrystallized rod portion 2b.

In FIG. 3, the recrystallization front 11 is shown to have flat wave-shaped and rounded-off rises or peaks when the plane in which the windings of the induction

heating coil are disposed extends at an angle inclined to the longitudinal axes of the rod holders, and the normals to the longitudinal axes of the rod holder for the recrystallized rod portion 2b define therebetween an acute angle of varying dimension from 0°. At the wave-shaped recrystallization front 11 in FIG. 3, only a small amount of material is periodically melted and hardened.

As shown in FIG. 4, it is especially advantageous if the normals to the plane in which the windings of the induction heating coil are disposed define with the longitudinal axis of the rod holder for the recrystallized rod an angle having a range of from 0.5° to 3°. In this case the recrystallization front 11 is virtually even or level so that the speed of crystal growth is practically uniform and the recrystallized rod portion 2b has at most only very few dislocations.

In order to zone melt by the crucible free method of this invention a 33 mm thick silicon rod 2, the device of this invention can be provided, for example, with an induction heating coil 10, such as is shown in FIG. 1, having a flat spiral coil with four windings provided with an inner diameter of 29 mm. The acute angle α between the normals 10a to the plane in which the windings 21 of the induction heating coil 10 are disposed and the longitudinal axes 5a and 6a of the rod holders 5 and 6, respectively, is 1°. The rod holder 5 is disposed within the acute angle β , after the molten zone is produced at the location at which the seed crystal 3 is fused to the silicon rod 2, so that longitudinal axes 5a and 6a of both rod holders 5 and 6, respectively, have a spacing of 7 mm. The longitudinal axis 5a of the rod holder 5 is disposed in the new starting position within the plane in which the angle α is disposed, i.e., the plane of the drawing in FIG. 1. The molten zone 8 is passed through the silicon rod 2 at a speed of 1-2 mm per minute. During the molten zone pass, the rod holder 5 with the recrystallized rod portion 2b is laterally reciprocated successively through 2 mm about the new starting position twenty times per minute.

In the device according to the invention, a recrystallized rod can also be formed having a diameter which is smaller or larger than the diameter of the starting rod.

Thus, by relatively displacing the rod holders toward one another, the diameter of the recrystallized rod can be increased, while by relatively displacing the rod holders away from one another the recrystallized rod can be reduced in diameter.

A connecting lead to the induction heating coil 10 can also be formed as a partial winding, for example, as a quarter winding which is located outside the plane in which the main windings of the induction heating coil are disposed. This partial winding is located at the level of the molten zone boundary 9 at the rod portion 2a which is to be zone melted, at that side of the plane in which the windings of the induction heating coil are disposed which faces toward the holder 6 for the rod portion 2a which is to be melted. If holder 6 is rotated about the longitudinal axis 6a thereof in the direction of the partial winding or the main winding of the induction heating coil 10, for example, at a speed of 0.1 r.p.m., the field emanating from the partial winding thus prevents the formation of hard points or projections at the boundary 9 of the molten zone which could, for example, contact the windings of the flat induction heating coil 10 to form a short circuit when the inner diameter of the coil 10 is smaller than the diameter of the rod portion 2a which is to be zone melted.

I claim:

1. In device for crucible-free zone melting a crystalline rod end-supported by holders of which one holder is rotatable about the longitudinal axis thereof, a flat induction heating coil surrounding the longitudinal axis of the other holder for heating a molten zone formed in the crystalline rod, said induction heating coil having a plurality of windings disposed in a single plane, said plane extending at an acute angle defined by a normal to said plane of said windings and the longitudinal axes of both of said rod holders having a value within the range of 0.5° to 3°.

2. The device of claim 1, wherein the rod holder rotatable about the longitudinal axis thereof is also laterally displaceable.

3. The device of claim 1, wherein the acute angle is between 1.0° and 1.5°.

* * * * *

45

50

55

60

65