



(22) Date de dépôt/Filing Date: 2013/01/24

(41) Mise à la disp. pub./Open to Public Insp.: 2014/07/24

(51) Cl.Int./Int.Cl. *E04B 5/16* (2006.01)

(71) Demandeur/Applicant:
FARESIN BUILDING DIVISION S.P.A., IT

(72) Inventeur/Inventor:
FARESIN, GUIDO, IT

(74) Agent: BERESKIN & PARR LLP/S.E.N.C.R.L.,S.R.L.

(54) Titre : APPAREIL D'EXECUTION DE MOULAGES HORIZONTALS POUR FOURNIR DES DALLES DE PLANCHER EN BETON

(54) Title: APPARATUS FOR PERFORMING HORIZONTAL CASTINGS TO PROVIDE FLOOR SLABS

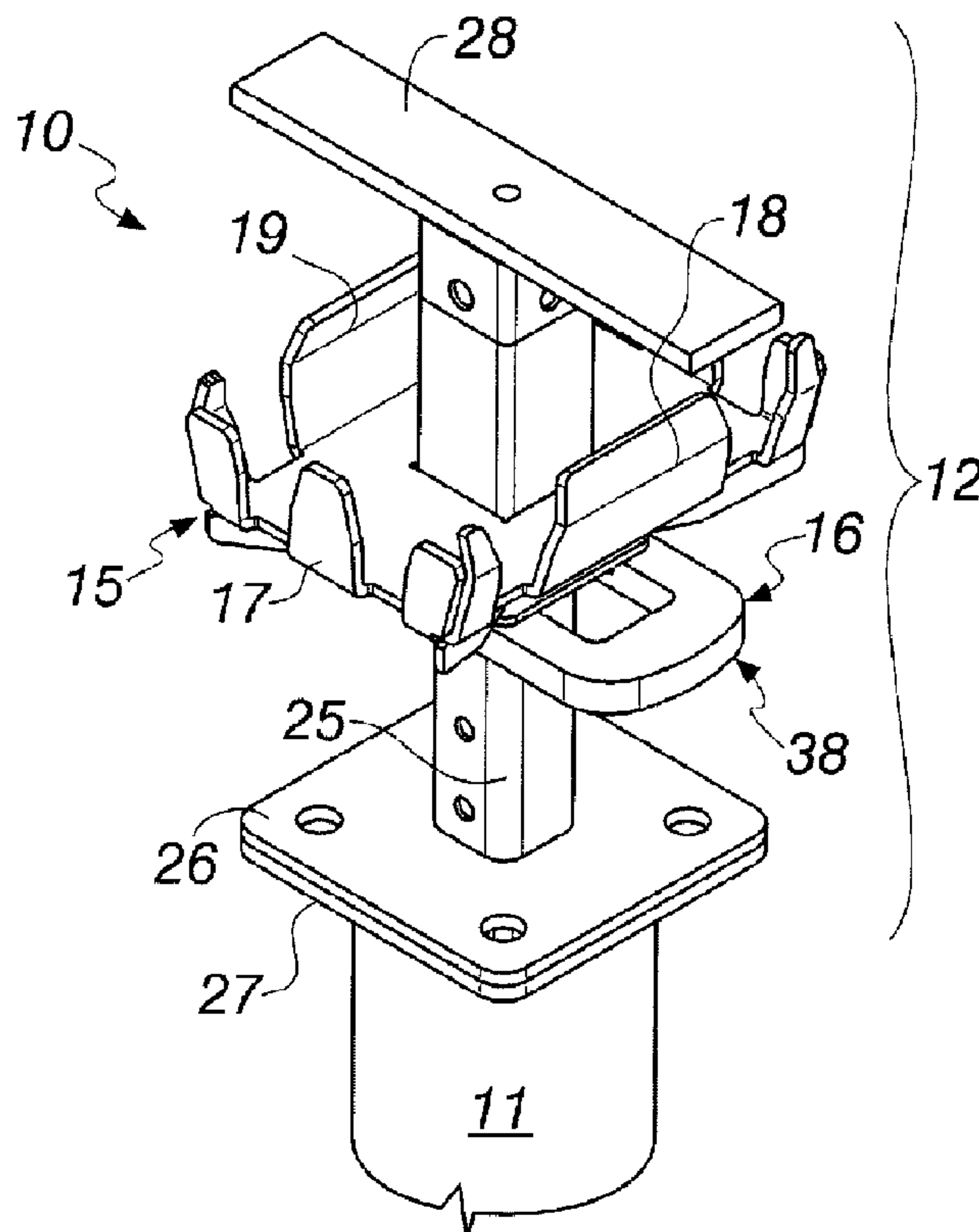

(57) Abrégé/Abstract:

An apparatus for performing horizontal castings to provide floor slabs, of the type comprising a series of props, and load-bearing heads to be arranged on the props for the resting of panels intended to form a surface for the concrete casting. The load-bearing heads are of the drop type, each head having a panel supporting plate that is shaped so as to receive by direct resting the corner portions of four nearby panels, the panel supporting plate being retained in a load-bearing configuration by reversible locking means.



APPARATUS FOR PERFORMING HORIZONTAL CASTINGS TO
PROVIDE FLOOR SLABS

Abstract of the disclosure

An apparatus for performing horizontal castings to provide floor
5 slabs, of the type comprising a series of props, and load-bearing heads to be
arranged on the props for the resting of panels intended to form a surface for
the concrete casting.

The load-bearing heads are of the drop type, each head having a panel
supporting plate that is shaped so as to receive by direct resting the corner
10 portions of four nearby panels, the panel supporting plate being retained in a
load-bearing configuration by reversible locking means.

The present invention relates to an apparatus for performing horizontal concrete castings to provide floor slabs.

5 Apparatuses comprising props, to be placed on the ground, and onto which load-bearing heads adapted to support the panels that form a horizontal surface on which the concrete is cast are to be fixed, are currently known for the production of horizontal concrete castings to provide floor slabs.

10 In a first type of these load-bearing heads, the heads are fixed, i.e., they directly support the panels of which the casting surface is to be constituted, but once casting has been performed it is not possible to move away the heads from the panels being used, and therefore it is not possible to remove the panels before the concrete has hardened completely for
15 convenient reuse to provide another floor slab.

A second type of these load-bearing heads is known as a drop head, having a head that is shaped appropriately to support a beam or the ends of two contiguous aligned beams.

20 These drop heads are provided with a mechanism that allows removing the actual load-bearing element from its functional configuration for supporting a beam in order to allow the removal of the beams and of the panels supported by the beams.

25 Therefore, whereas with the first type of fixed head it is not possible to perform early formwork removal, i.e., the entire panel supporting structure remains engaged until the casting has hardened completely, with drop heads early formwork removal is possible but only by resorting to the aid of beams for supporting the panels, and therefore the structure is more expensive and more complicated to use than the supporting structure with fixed heads.

30 The aim of the present invention is to provide an apparatus for

performing horizontal concrete castings to provide floor slabs that is capable of obviating the cited drawbacks of the background art.

Within this aim, an object of the invention is to provide an apparatus that combines the advantages of props with drop head with the simplicity of supporting structures without beams.

Another object of the invention is to provide an apparatus that can be applied to props of the known type and can also be easily adapted to support panels for floor slabs also of a known type.

A further object of the invention is to provide an apparatus that can be handled in a simple and quick manner with known tools and without the aid of specially provided dedicated equipment.

Another object of the invention is to propose an apparatus for performing horizontal concrete castings to provide floor slabs that can be provided by means of known systems and technologies.

This aim, as well as these and other objects that will become more apparent hereinafter, are achieved by an apparatus for performing horizontal castings to provide floor slabs, of the type comprising a series of props, and load-bearing heads to be arranged on said props for the resting of panels intended to form a surface for a concrete casting, said load-bearing heads being of the drop type, each head having a panel supporting plate that is shaped so as to receive by direct resting the corner portions of four nearby panels, said panel supporting plate being retained in a load-bearing configuration by reversible locking means, said improved apparatus being characterized in that said drop head comprises a guiding post on which said panel supporting plate is arranged so as to perform a translational motion between a lower quadrangular plate, for fixing the load-bearing head, and an upper plate, for the resting of a closure profile to be interposed between two rows of adjacent panels, said reversible locking means for stabilizing the load-bearing configuration for said panel supporting plate comprising a locking plate, which is arranged so as to perform a translational motion on

the guiding post below the panel supporting plate and adapted to support said panel supporting plate, said locking plate having a central window, a first part of which is provided with edges which are contoured to allow the sliding of the locking plate on the post, whereas a second part is provided with wedge-shaped internal longitudinal protrusions which are preset and shaped so as to slide inside two corresponding guiding and locking recesses provided in the guiding post.

Further characteristics and advantages of the invention will become more apparent from the description of a preferred but not exclusive embodiment of an apparatus for performing horizontal concrete castings to provide floor slabs according to the invention, illustrated by way of non-limiting example in the accompanying drawings, wherein:

Figure 1 is a perspective view of an apparatus according to the invention in the configuration for use;

Figure 2 is a perspective view of Figure 1 with the apparatus according to the invention in a formwork removal configuration;

Figure 3 is an exploded perspective view of the apparatus according to the invention;

Figure 4 is a front view of a detail of the apparatus according to the invention;

Figure 5 is the sectional view indicated by the line V-V of Figure 4;

Figure 6 is a plan view of a component of the apparatus according to the invention;

Figure 7 is a sectional view indicated by the line VII-VII in Figure 6;

Figure 8 is a perspective view of the component of Figures 6 and 7;

Figure 9 is a side view of the detail of Figure 4;

Figures 10 and 11 are schematic sectional side views of the apparatus according to the invention, exemplifying its operation;

Figure 12 is a bottom perspective view of a further component of the apparatus according to the invention;

Figure 13 is a top view of an apparatus according to the invention in the configuration for use.

With reference to the cited figures, an apparatus for performing horizontal concrete castings to provide floor slabs is generally designated by
5 the reference numeral 10.

The apparatus 10 comprises a series of props 11 and load-bearing heads 12 to be arranged on the props 11 for the resting of panels, two of which are designated by the reference numerals 13 and 14, are shown by way of example in Figure 12 and are intended to form a surface for a
10 concrete casting.

The particularity of the invention resides in that the load-bearing heads 12 are of the drop type.

Each one of the drop heads 12 has a panel supporting plate 15 that is shaped to receive by direct resting the corner portions of four nearby panels.

15 The panel supporting plate 15 is retained in the supporting configuration by reversible locking means 16 described in greater detail hereinafter.

The panel supporting plate 15 of the drop head 12, in the embodiment of the invention described herein by way of non-limiting example of the
20 present invention, is substantially quadrilateral, with central engagement wings, for example 17, 18 and 19, and corner wings, for example 20, 21 and 22, which extend upward for engagement in corresponding openings formed below the corner portions of said panels 13 and 14.

The drop head 12 comprises, as has been mentioned, the panel
25 supporting plate 15, that is arranged so as to translate on a guiding post 25 between a lower quadrangular plate 26, for fixing to the upper end plate 27 of a prop 11, as shown in Figure 1, and an upper plate 28, for the resting of a closure profile to be interposed between two rows of adjacent panels.

The lower plate 26 and upper plate 28 are arranged at the ends,
30 respectively the lower end 30 and the upper end 31, of the guiding post 25.

The guiding post 25 is constituted by a tubular element having a quadrangular cross-section, which is designed to be fixed to the lower plate 26 by the coupling of a tubular portion 32 having a complementary shaped cross-section, to which the lower plate 26 is welded in a substantially
5 central region.

The upper part 32a of the tubular portion 32 is adapted to be inserted in the lower end 30 of the post 25; the lower part 32b of the tubular portion 32 is instead designed to be inserted in the head of the prop 11.

In the present constructive example, the tubular portion 32 is fixed to
10 the tubular post 25 by means of a pair of pins 33.

The upper plate 28 is fixed to the guiding post 25 by means of the interposition of an additional tubular portion 29, to which the upper plate 28 is welded, and in turn is welded to the upper end 31 of the guiding post 25.

A sliding sleeve 35 is fixed to the panel supporting plate 15 at a
15 central opening 34 thereof for the passage of said guiding post 25 and has a cross-section that is shaped complementary with respect to the guiding post 25, in order to slide without rotating on the guiding post 25.

The reversible locking means 16 for stabilizing the load-bearing configuration for said panel supporting plate 15 comprise a locking plate 38,
20 which is arranged so as to translate on the guiding post 25 below the panel supporting plate 15 and is adapted to support the panel supporting plate 15.

The locking plate 38 has a central window 39, a first part 39a of which is provided with edges 40 that are shaped so as to allow the sliding of the locking plate 38 on the post 25, while a second part 39b has wedge-
25 shaped internal longitudinal protrusions, respectively 41 and 42, which are designed and shaped to slide within two corresponding guiding and locking recesses 43 and 44 provided in the guiding post 25.

The wedge-shaped longitudinal protrusions 41 and 42 are arranged in front of each other, are symmetrical and wedge-shaped in the direction of
30 the thickness of the locking plate 38, with a height that decreases from the

outer edge 45 of the second part 39b of the central window 39, where there is a first height A1, toward the region 46 for connection between the second part 39b and the first part 39a, where the height of the end of the wedge-shaped protrusions is A2, smaller than A1, as is clearly visible in Figure 7.

5 The two guiding recesses 43 and 44 are each constituted by an opening provided in the tubular guiding post 25, the opening extending until it affects also the connecting corner regions between two contiguous faces of the guiding post 25; Figure 5 clearly shows this constructive solution, where the connecting corner regions are designated respectively by 43a and
10 43b for the first guiding recess 43 and by 44a and 44b for the second guiding recess 44.

In this manner, the resting and abutment surface for the corresponding wedge-shaped protrusions 41 and 42 is such as to allow a stable locking thereof and at the same time a loading capacity that is
15 sufficient for the requirements.

The guiding recesses 43 and 44 extend with an inclination, with respect to a plane that is parallel to the lower plate 26, that is designated by the angle W in Figure 9.

This inclination is the same one that the wedge-shaped longitudinal
20 protrusions 41 and 42 have in the direction of the axis of the guiding post 25 in the configuration for use, as indicated by the angle W shown in Figure 7.

This causes the sliding of the wedge-shaped protrusions 41 and 42 in the respective recesses 43 and 44 to occur so that the locking plate 38,
25 during the locking operation, i.e., during the forcing of the wedge-shaped protrusions 41 and 42 in the respective recesses 43 and 44, remains parallel to itself, i.e., so that it does not tilt incorrectly with respect to the surface of panels to be provided.

To allow the guiding post 25 to transmit the load to the underlying
30 prop 11 correctly without being deformed, inside the guiding post 45, at the

recesses 43 and 44, there is a reinforcement element 47, which in the present constructive example, which obviously does not limit the invention, is constituted by a tubular portion, clearly visible in Figure 5 and shown in dashed lines in Figures 4 and 9, which is welded thereat and is adapted to cooperate in load transmission.

It should be understood that this tubular portion can be replaced in an equivalent manner by a flat element or other similar and equivalent reinforcement element.

The reinforcement element 47 has a transverse cross-section such as not to interfere with the passage openings of the wedge-shaped protrusions 41 and 42 of the locking plate 38.

The maximum transverse width B of the locking plate 38, shown in Figure 6, is such that the locking plate 38 is never a hindrance for the assembly and disassembly operations of the panels, for example the panel 14 in Figure 13.

The operation of the apparatus 10 according to the invention is as follows.

Figure 10 shows the locking plate 38 supported at the height of the recesses 43 and 44, of which the recess 43 is visible in the partially sectional figure, with the locking plate 38 arranged with the first part 39a of the central window 39, in the configuration for vertical sliding of the plate 38, arranged so as to surround the guiding post 25.

Figure 11 shows the locking plate 38 in the locking configuration, with the wedge-shaped protrusions 41 and 42, of which a first wedge-shaped protrusion 41 is visible, forced in the respective recesses 43 and 44.

The overall operation for locking the load-bearing head 12 therefore provides for lifting the locking plate 38, with the panel supporting plate 15 above it, from the completely lowered position, such as for example in Figure 2, to an intermediate position, as in Figure 10, and then pushing the locking plate 38 to translate so that, as already mentioned, the internal

longitudinal wedge-shaped protrusions 41 and 42 enter the recesses 43 and 44.

This operation of translation of the locking plate 38 can be provided at the building site by striking with a hammer or other similar tool.

5 Likewise, formwork removal of the load-bearing head 12 occurs by striking the locking plate 38 in the opposite direction.

In order to prevent inaccurate blows applied to the locking plate 38 from being able to reach the panel supporting plate 15 and possibly compromising its integrity and functionality, said plate is provided in a
10 lower region with a frame 50 for reinforcement and spacing from the underlying locking plate 38.

The reinforcement frame 50 is constituted for example, as shown in Figure 12, by four vertical walls 51, 52, 53, 54, which are welded below the plate and extend from the outer corners thereof to the corners of the sliding
15 sleeve 35.

In practice it has been found that the invention achieves the intended aim and objects.

The apparatus according to the invention in fact allows the direct use of panels that can be rested directly on the drop head supported by the prop,
20 allowing simultaneously the removal of the surface formed by the panels from the surface of the concrete casting, so as to allow early formwork removal of the structure.

In particular, the invention provides an apparatus that combines the advantages of props with drop head with the simplicity of supporting
25 structures without beams, by means of the particular drop head with panel supporting plate.

Moreover, the invention provides an apparatus that can be applied to props of a known type and can be adapted easily to support panels for floor slabs also of a known type.

30 Moreover, the invention provides an apparatus that can be handled

simply and quickly with known tools and without the aid of specifically provided dedicated equipment by easy maneuvering of the locking plate.

Moreover, the invention provides an apparatus that does not constitute a hindrance during formwork removal and removal of the
5 supported panels.

Last but not least, the invention provides an apparatus for performing horizontal concrete castings to provide floor slabs that can be provided by means of known systems and technologies.

The invention thus conceived is susceptible of numerous
10 modifications and variations, all of which are within the scope of the appended claims; all the details may further be replaced with other technically equivalent elements.

In practice, the materials used, as well as the contingent shapes and dimensions, may be any according to the requirements and the state of the
15 art.

THE EMBODIMENTS OF THE INVENTION IN WHICH AN EXCLUSIVE PROPERTY OR PRIVILEGES IS CLAIMED ARE DEFINED AS FOLLOWS:

1. An apparatus (10) for performing horizontal castings to provide
5 floor slabs, of the type comprising a series of props (11), and load-bearing
heads (12) to be arranged on said props (11) for the resting of panels (13,
14) intended to form a surface for a concrete casting, said load-bearing
heads (12) being of the drop type, each head having a panel supporting plate
(15) that is shaped so as to receive by direct resting the corner portions of
10 four nearby panels, said panel supporting plate (15) being retained in a load-
bearing configuration by reversible locking means, characterized in that said
drop head (12) comprises a guiding post (25) on which said panel
supporting plate (15) is arranged so as to perform a translational motion
between a lower quadrangular plate (26), for fixing the load-bearing head
15 (12), and an upper plate (28), for the resting of a closure profile to be
interposed between two rows of adjacent panels, said reversible locking
means (16) for stabilizing the load-bearing configuration for said panel
supporting plate (15) comprising a locking plate (38), which is arranged so
as to perform a translational motion on the guiding post (25) below the
20 panel supporting plate (15) and adapted to support said panel supporting
plate (15), said locking plate (38) having a central window (39), a first part
(39a) of which is provided with edges (40) which are contoured to allow the
sliding of the locking plate (38) on the post (25), while a second part (39b)
is provided with wedge-shaped internal longitudinal protrusions (41, 42)
25 which are preset and shaped so as to slide inside two corresponding guiding
and locking recesses (43, 44) provided in the guiding post (25).

2. The apparatus according to claim 1, characterized in that said
wedge-shaped internal longitudinal protrusions (41, 42) are wedge-shaped
in the direction of the thickness of the locking plate (38), with a height that
30 decreases from the outer edge (45) of the second part (39b) of the central

window (39), where there is a first height (A1), toward the region for connection (46) between the first part (39a), the second part (39b), where the height (A2) of the end of the wedge-shaped protrusions is lower than the height (A1) of the outer edge (45).

5 3. The apparatus according to one or more of the preceding claims, characterized in that said two guiding recesses (43, 44) are each constituted by an opening provided in the tubular guiding post (25).

 4. The apparatus according to claim 3, characterized in that each one of the openings that define said guiding recesses (43, 44) extends until it
10 affects the corner regions (43a, 43b, 44a, 44b) that connect two contiguous faces of the guiding post (25).

 5. The apparatus according to one or more of the preceding claims, characterized in that said guiding recesses (43, 44) extend with an inclination (W) with respect to a plane that is parallel to the lower plate
15 (26).

 6. The apparatus according to one or more of the preceding claims, characterized in that said inclination (W) is the same as that of the wedge-shaped longitudinal protrusions (41, 42) in the direction of the axis of the guiding post (25) in the configuration for use.

20 7. The apparatus according to one or more of the preceding claims, characterized in that a reinforcement element (47) adapted to cooperate in load transmission is arranged inside the guiding post (45) at the recesses (43, 44).

 8. The apparatus according to one or more of the preceding claims,
25 characterized in that said reinforcement element (47) has such a transverse cross-section as not to interfere with the passage openings of the wedge-shaped protrusions (41, 42) of the locking plate (38).

 9. The apparatus according to one or more of the preceding claims, characterized in that the maximum transverse width (B) of the locking plate
30 (38) is such that the locking plate (38) is never a hindrance for the

operations for assembling and disassembling the panels.

10. The apparatus according to one or more of the preceding claims, characterized in that said panel supporting plate (15) is provided, in a lower region, with a frame (50) for reinforcement and spacing from the underlying
5 locking plate (38).

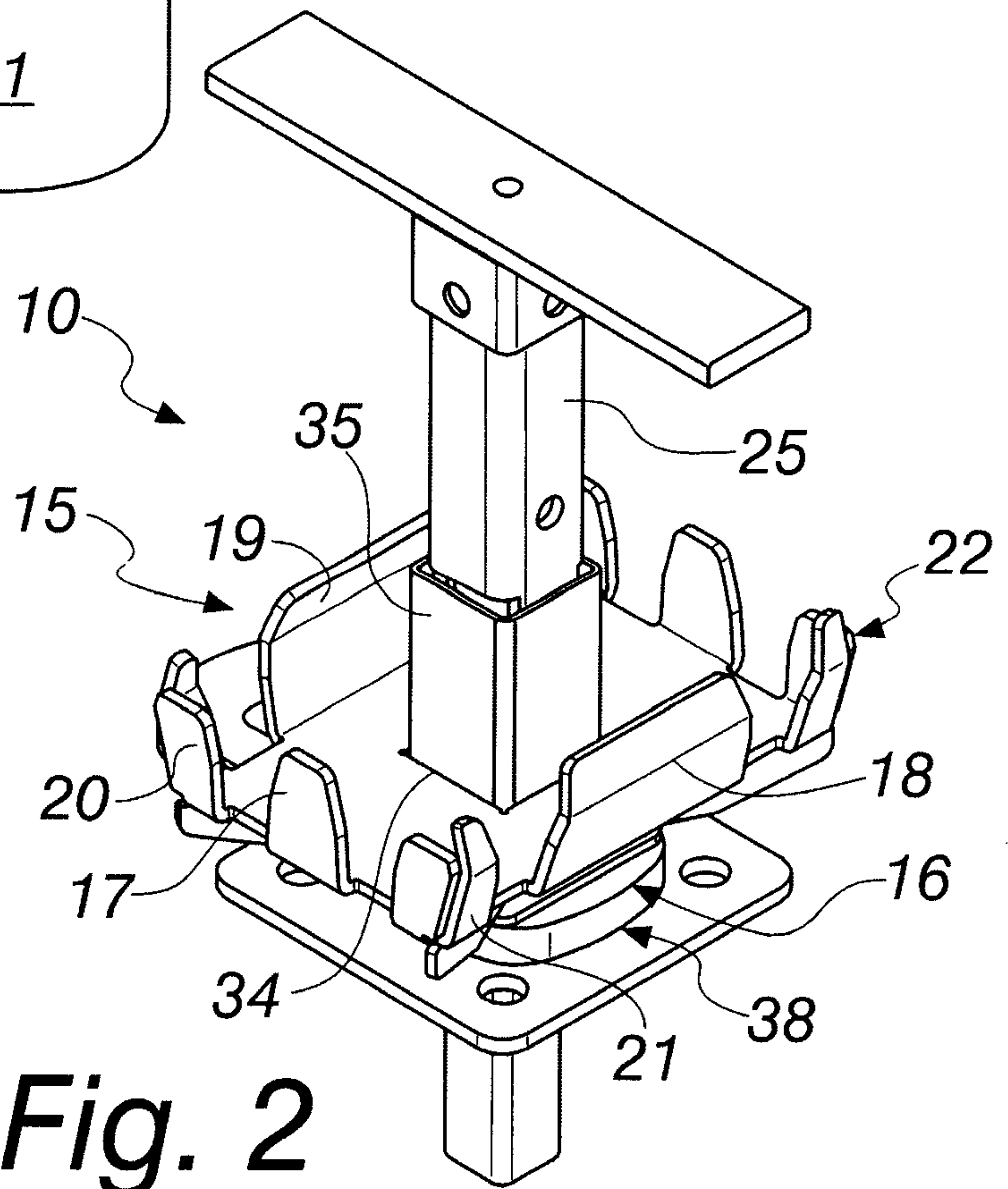
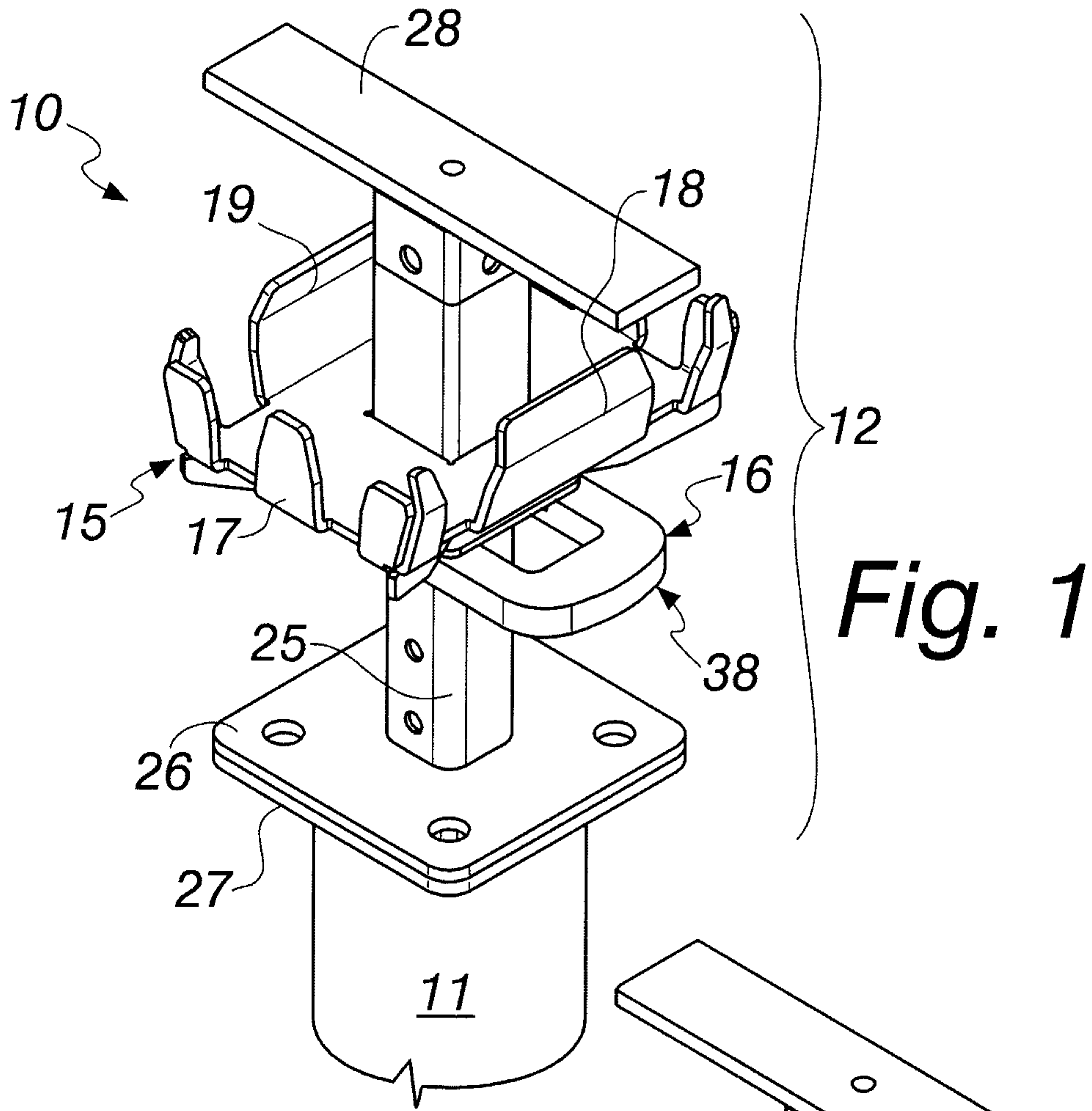

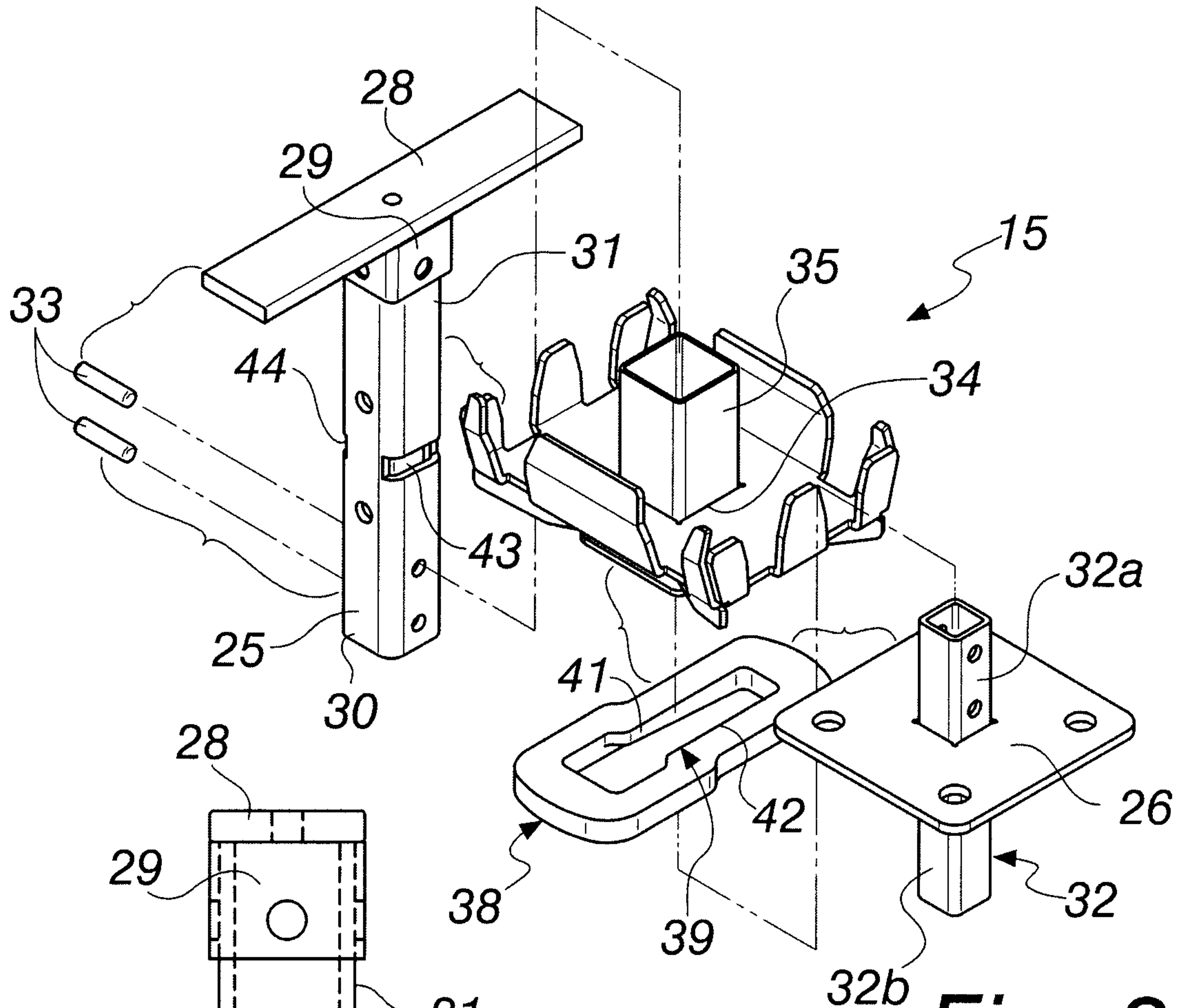

Fig. 3

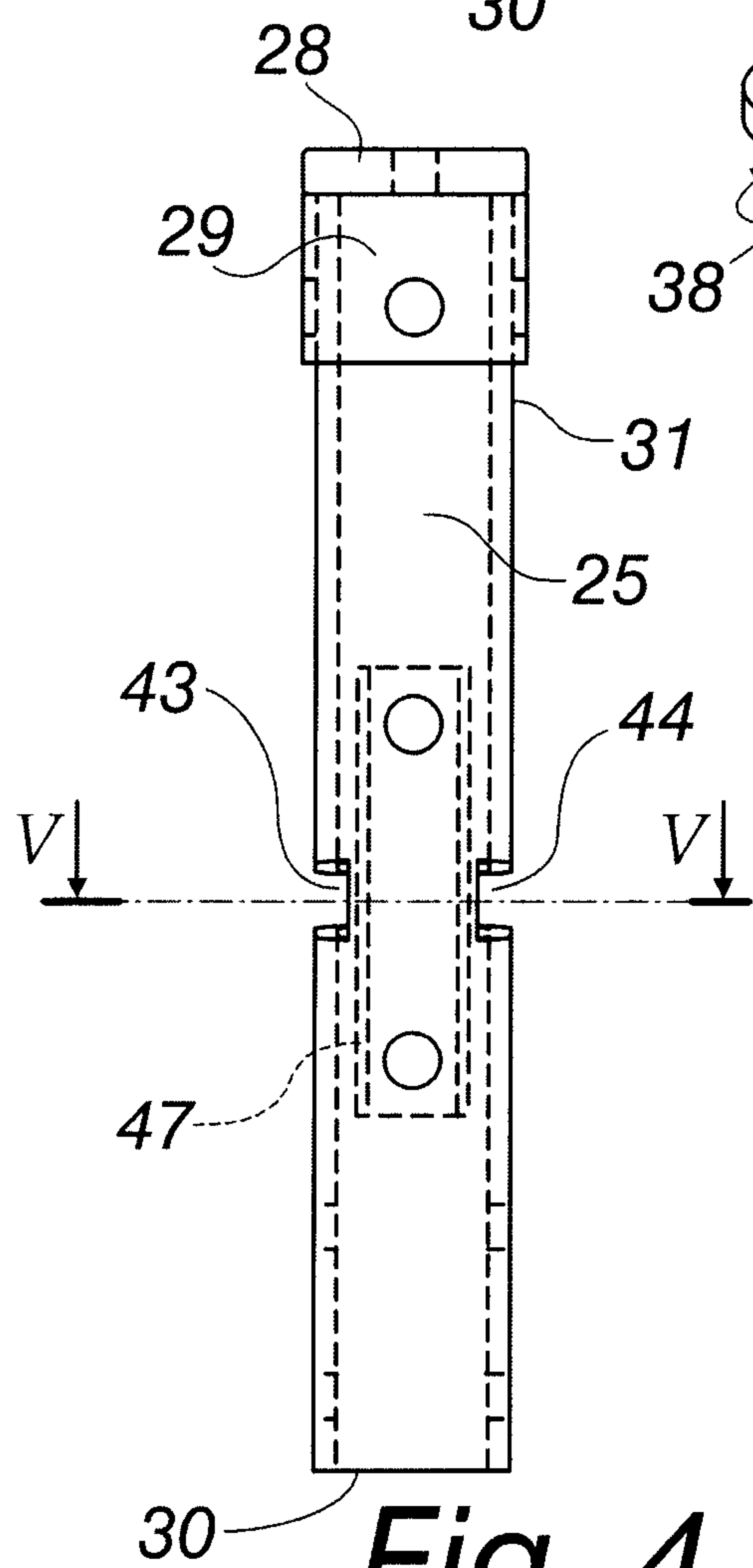

Fig. 4

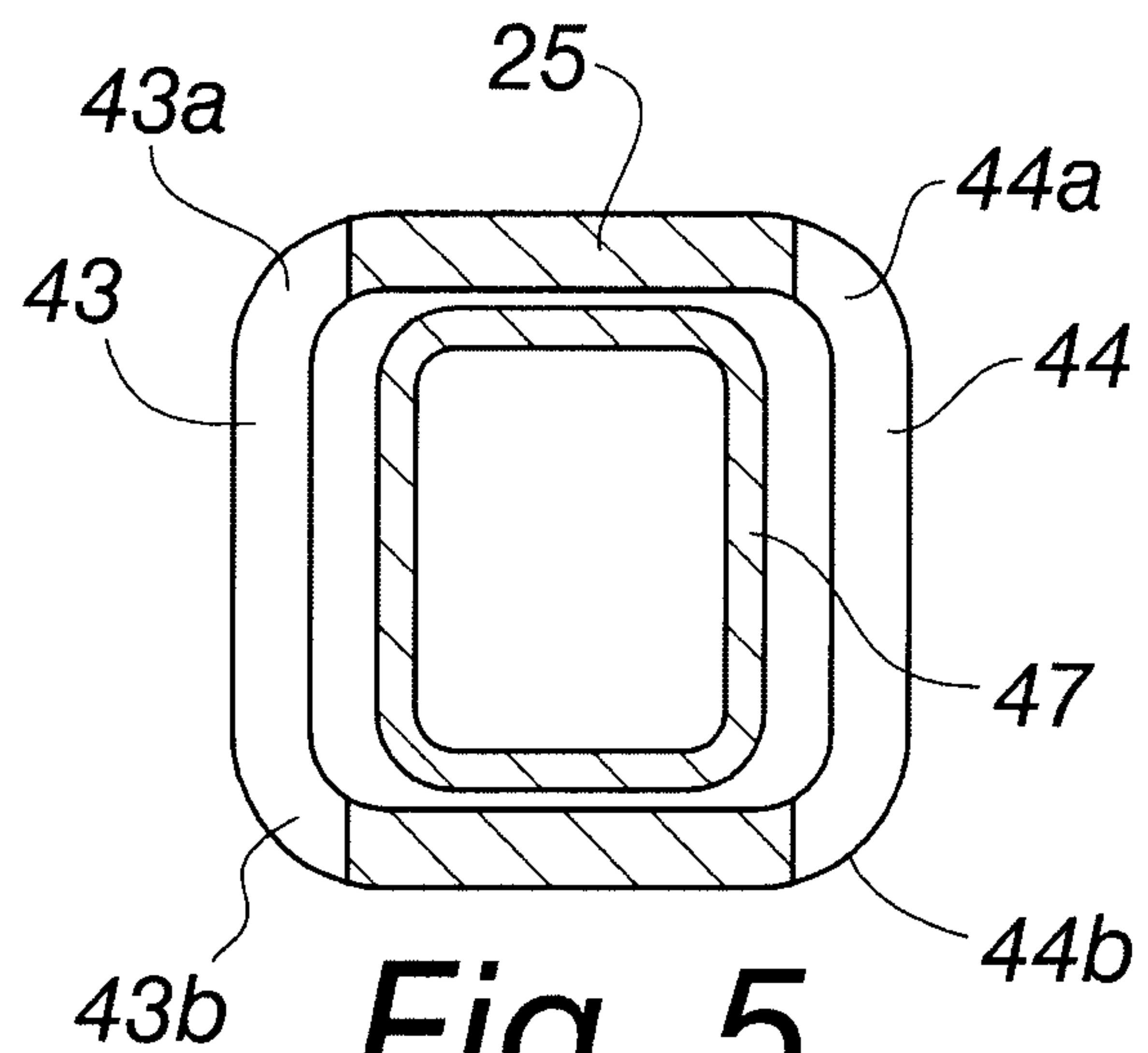

Fig. 5

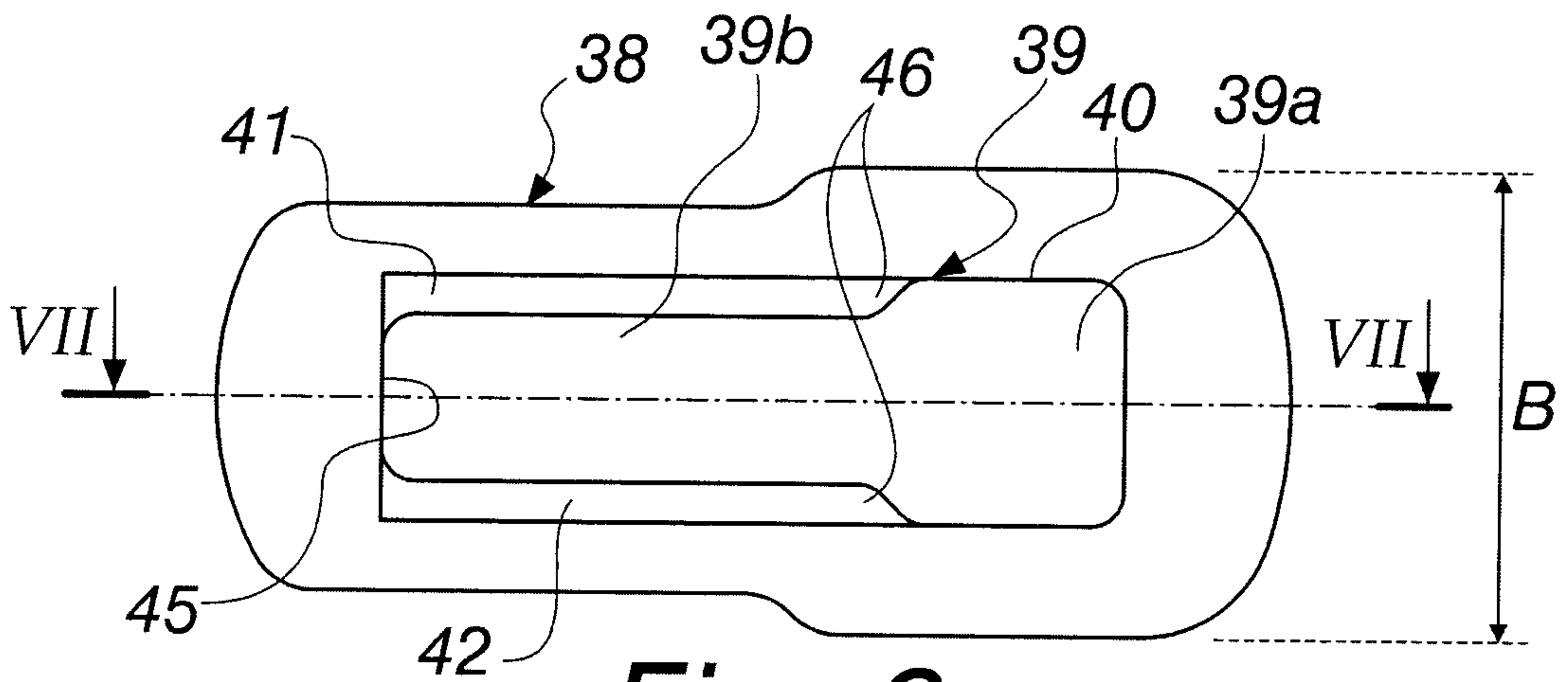

Fig. 6

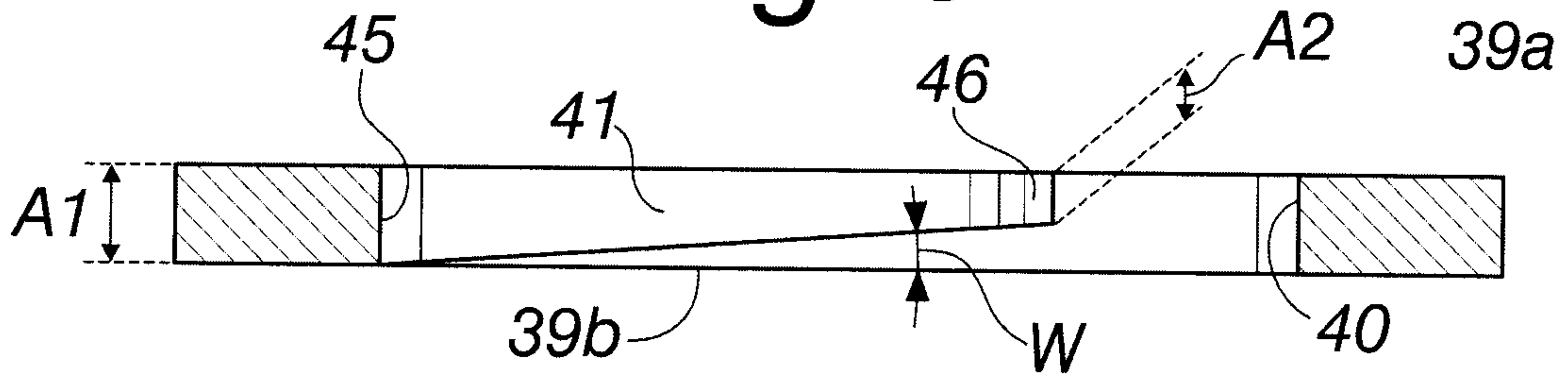

Fig. 7

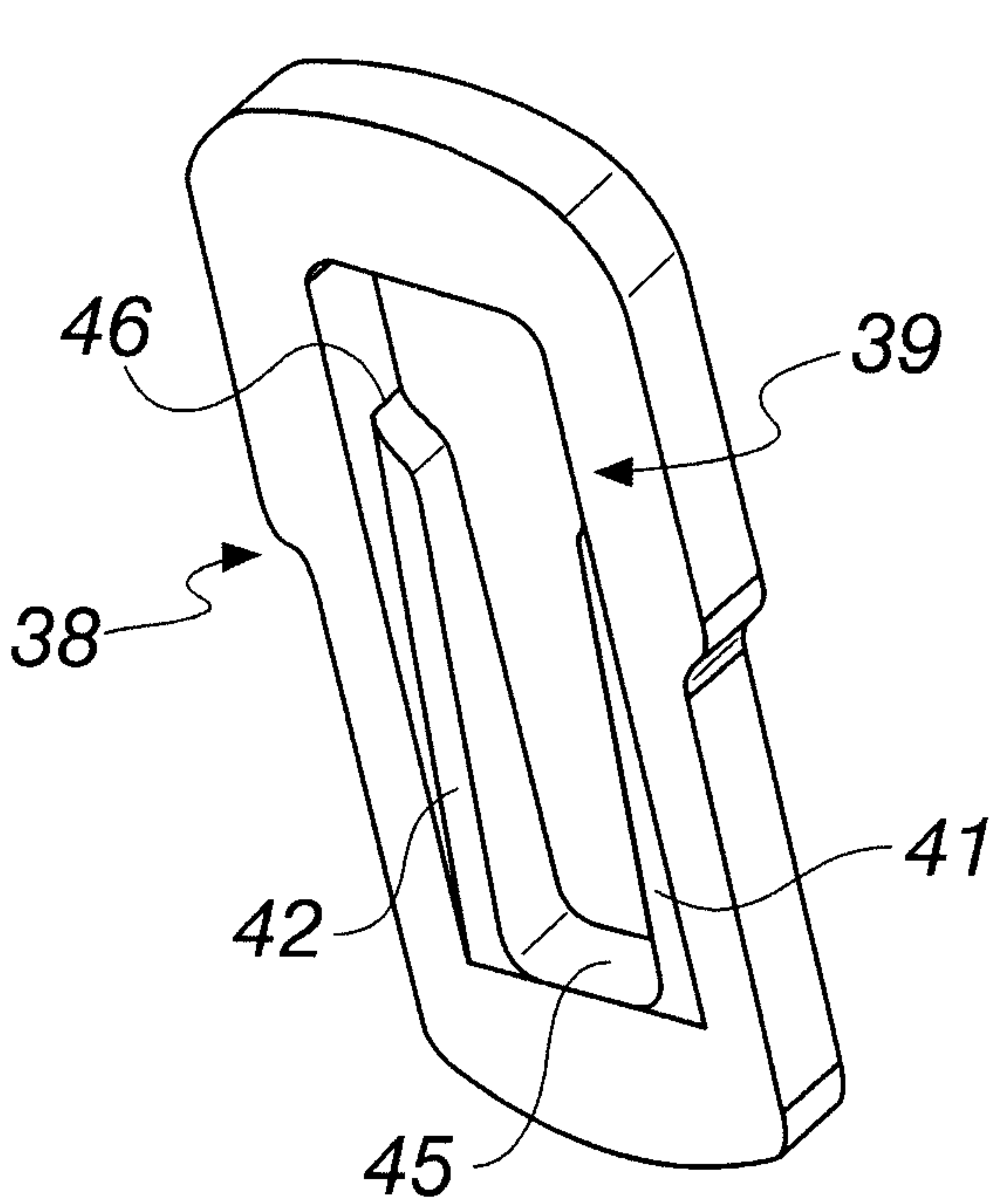

Fig. 8

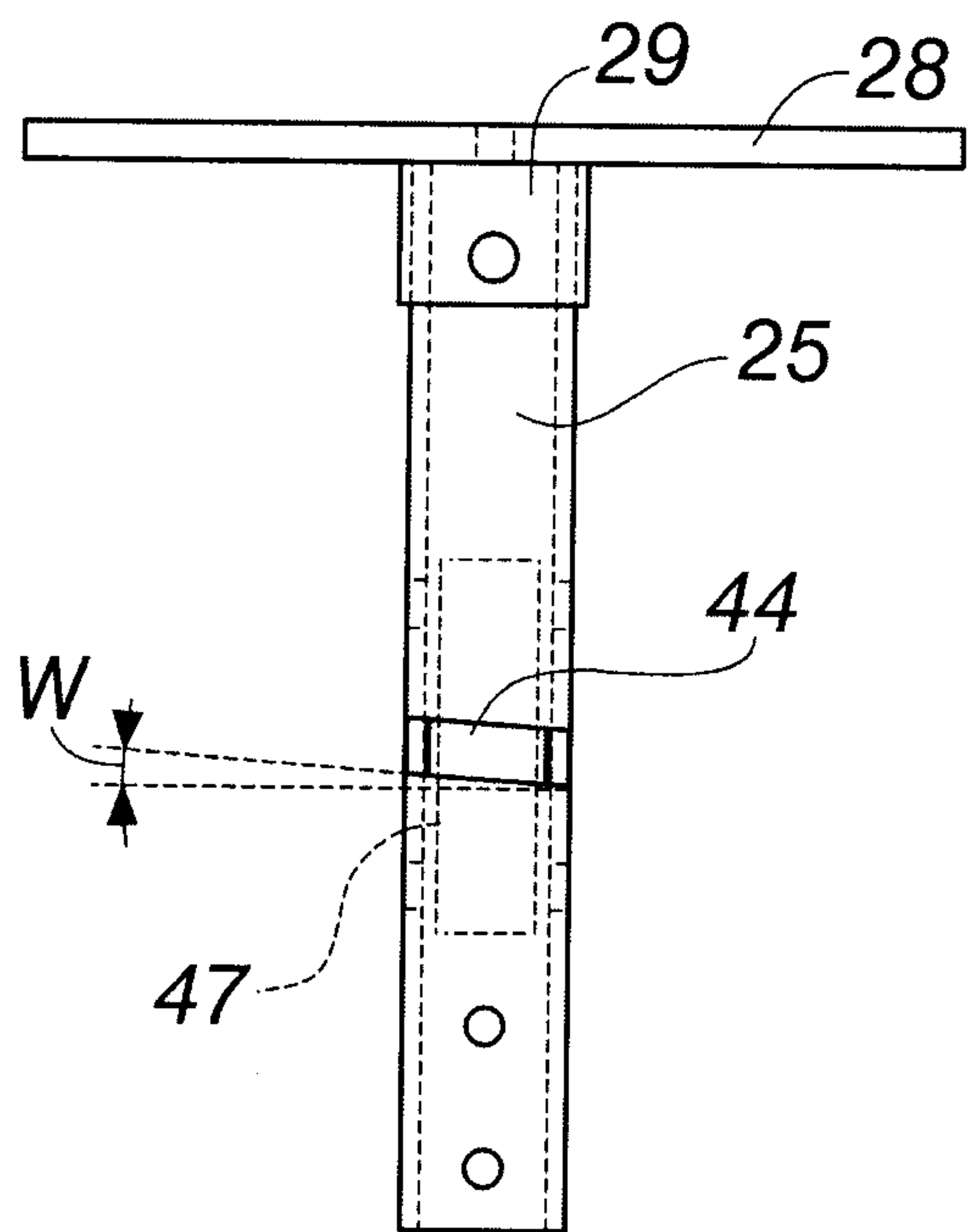

Fig. 9

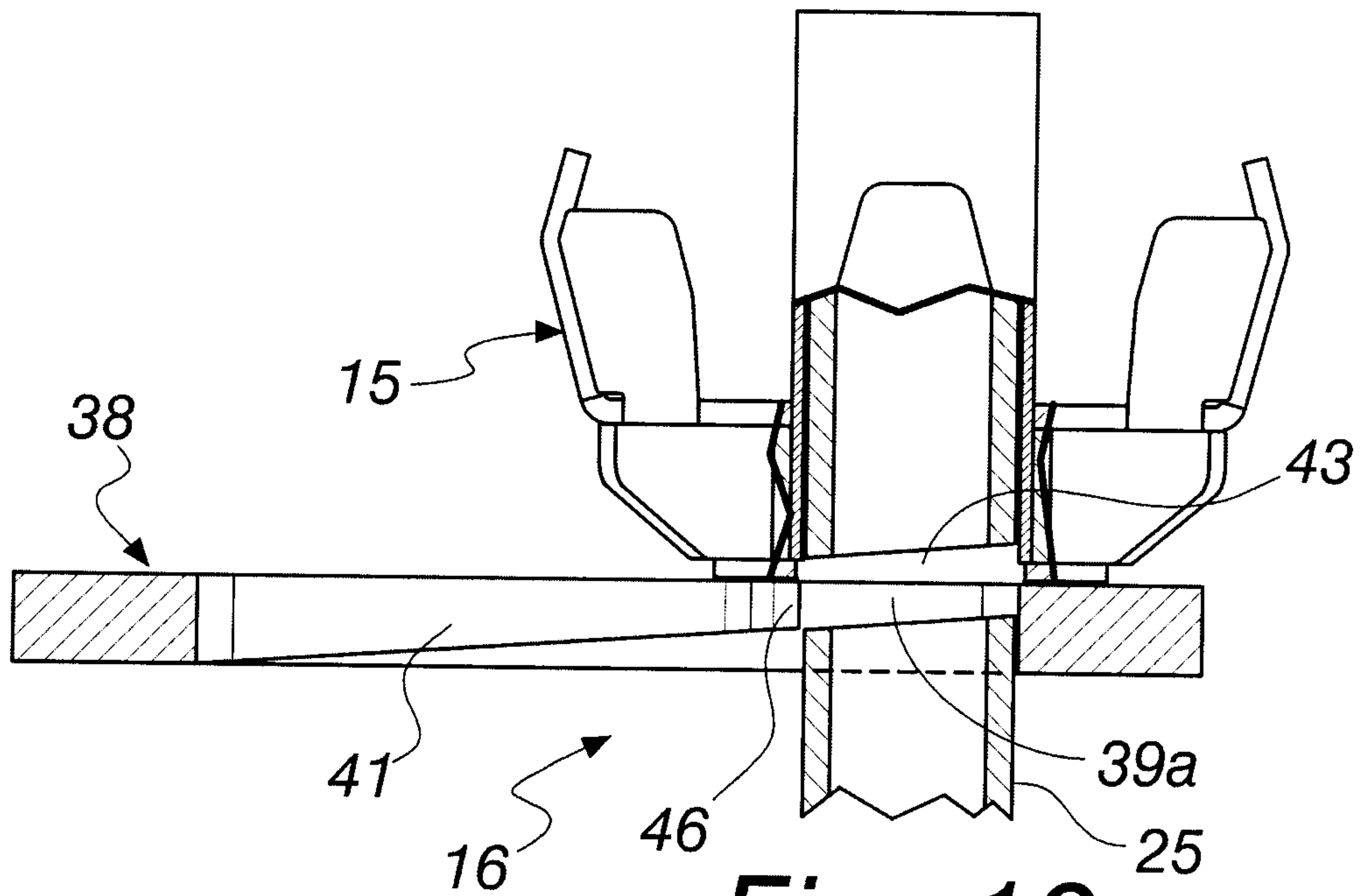

Fig. 10

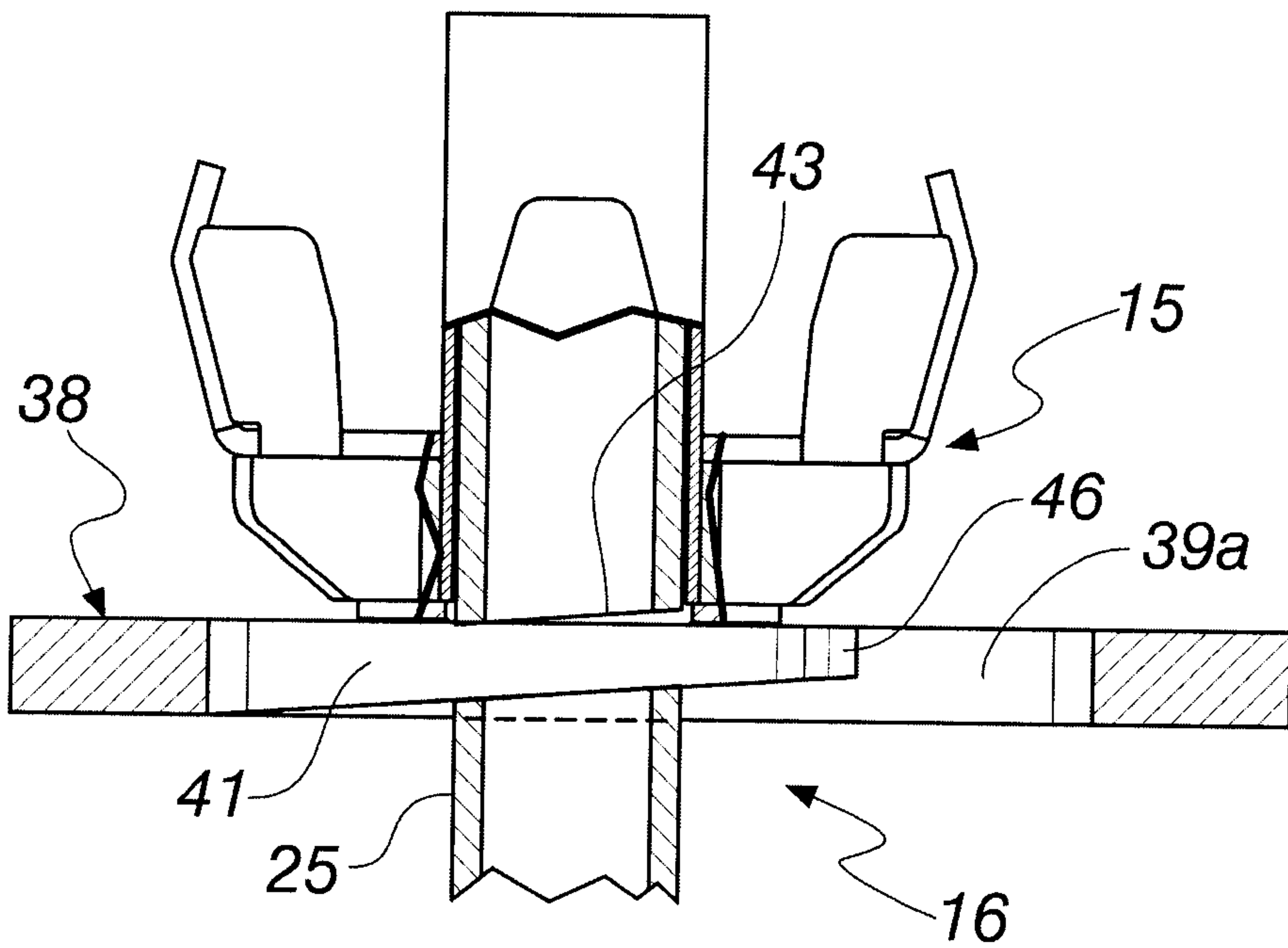

Fig. 11

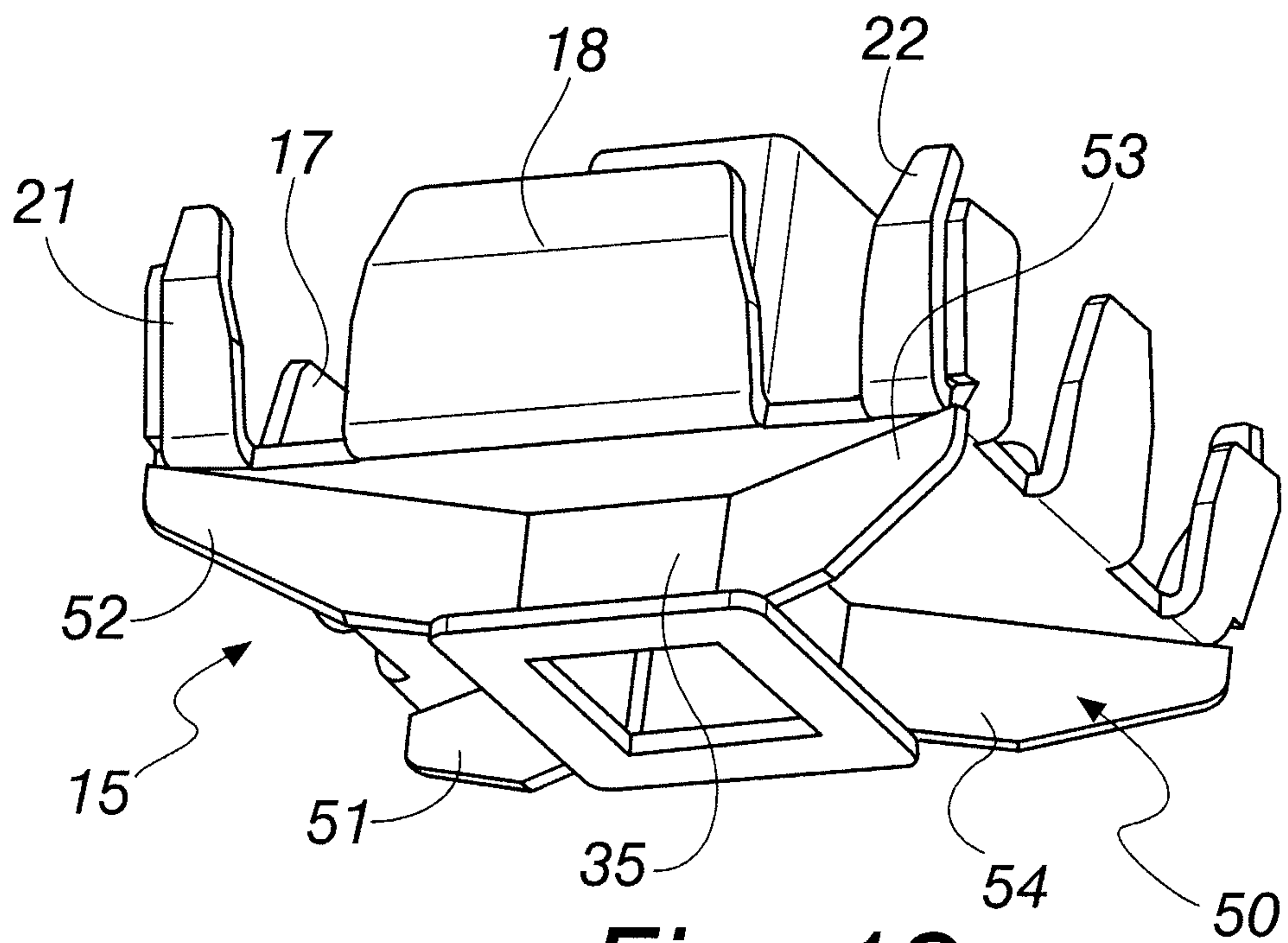

Fig. 12

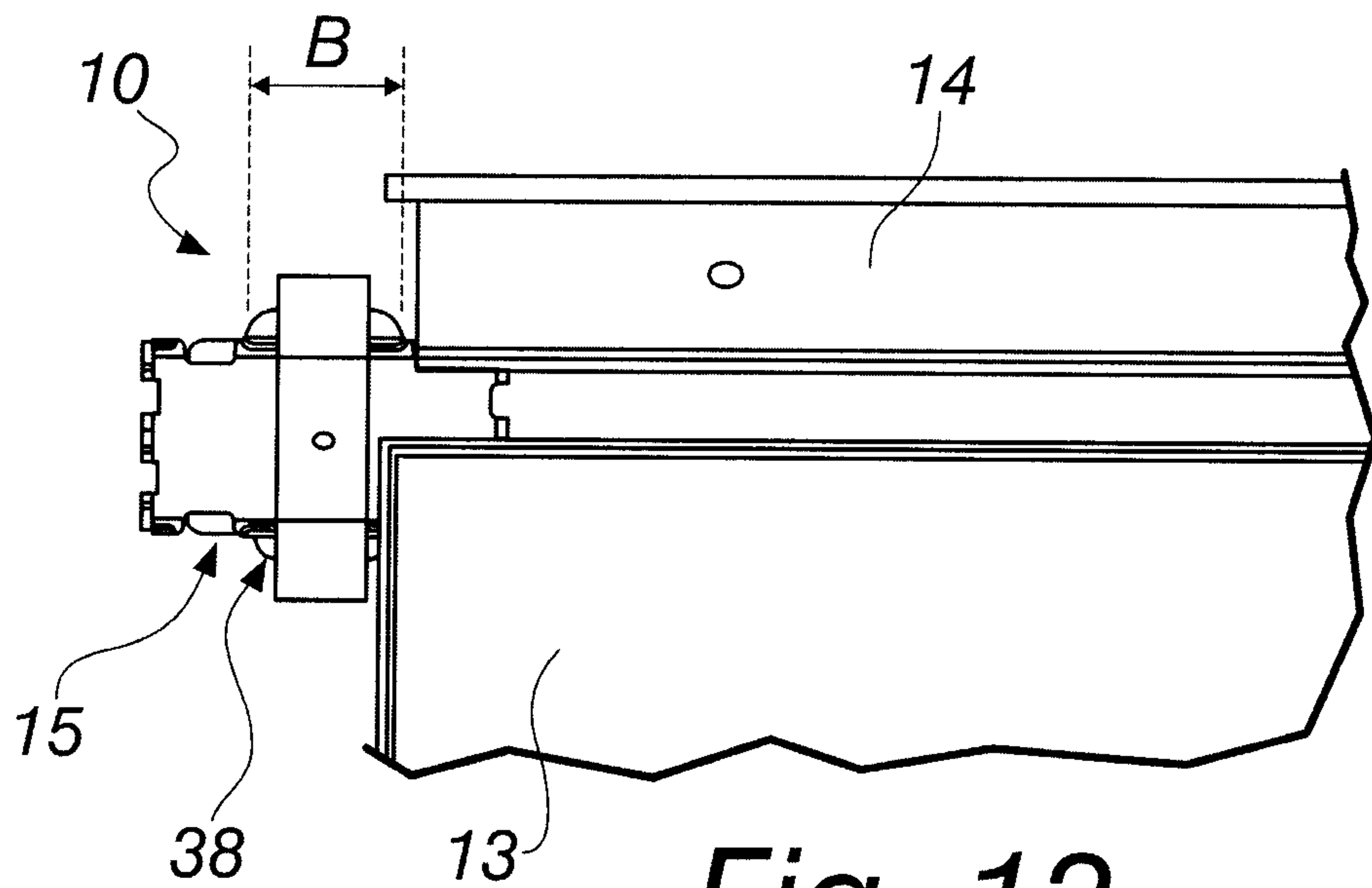

Fig. 13

