

(19) World Intellectual Property Organization
International Bureau



(43) International Publication Date
30 March 2006 (30.03.2006)

PCT

(10) International Publication Number
WO 2006/032099 A2

(51) International Patent Classification: Not classified

(21) International Application Number:
PCT/AU2005/001454

(22) International Filing Date:
22 September 2005 (22.09.2005)

(25) Filing Language: English

(26) Publication Language: English

(30) Priority Data:
2004905447 22 September 2004 (22.09.2004) AU

(71) Applicant (for all designated States except US): **BTEQ PTY LTD** [AU/AU]; Suite 3, 13 Cameron Street, Beenleigh, Queensland 4207 (AU).

(72) Inventors; and

(75) Inventors/Applicants (for US only): **POHLNER, Benjamin Mark** [AU/AU]; 17 Rowe Street, Earlville, Queensland 4870 (AU). **TRINDER, Kevin Vincent** [AU/AU]; 18 Nelson Parade, Manly, Queensland 4179 (AU).

(74) Agent: **CULLEN & CO**; Level 26, 239 George Street, Brisbane, Queensland 4000 (AU).

(81) Designated States (unless otherwise indicated, for every kind of national protection available): AE, AG, AL, AM, AT, AU, AZ, BA, BB, BG, BR, BW, BY, BZ, CA, CH, CN, CO, CR, CU, CZ, DE, DK, DM, DZ, EC, EE, EG, ES, FI, GB, GD, GE, GH, GM, HR, HU, ID, IL, IN, IS, JP, KE, KG, KM, KP, KR, KZ, LC, LK, LR, LS, LT, LU, LV, LY, MA, MD, MG, MK, MN, MW, MX, MZ, NA, NG, NI, NO, NZ, OM, PG, PH, PL, PT, RO, RU, SC, SD, SE, SG, SK, SL, SM, SY, TJ, TM, TN, TR, TT, TZ, UA, UG, US, UZ, VC, VN, YU, ZA, ZM, ZW.

(84) Designated States (unless otherwise indicated, for every kind of regional protection available): ARIPO (BW, GH, GM, KE, LS, MW, MZ, NA, SD, SL, SZ, TZ, UG, ZM, ZW), Eurasian (AM, AZ, BY, KG, KZ, MD, RU, TJ, TM), European (AT, BE, BG, CH, CY, CZ, DE, DK, EE, ES, FI, FR, GB, GR, HU, IE, IS, IT, LT, LU, LV, MC, NL, PL, PT, RO, SE, SI, SK, TR), OAPI (BF, BJ, CF, CG, CI, CM, GA, GN, GQ, GW, ML, MR, NE, SN, TD, TG).

Published:

— without international search report and to be republished upon receipt of that report

For two-letter codes and other abbreviations, refer to the "Guidance Notes on Codes and Abbreviations" appearing at the beginning of each regular issue of the PCT Gazette.

(54) Title: AQUACULTURE METHOD AND SYSTEM

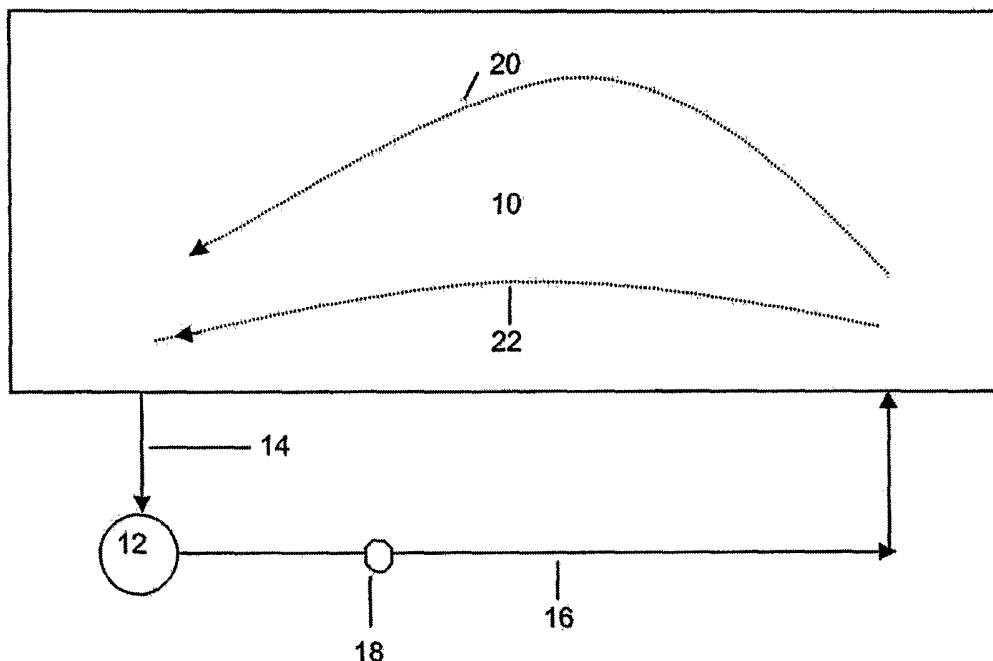

(57) Abstract: An aquaculture method for growing crustaceans or fish for harvest in which crustaceans or fish are placed in a body of water, characterised in that the water is treated to reduce a concentration of growth inhibiting compound therein. The growth limiting compound may be a growth limiting hormone. When the method is used to grow crustaceans, the growth limiting hormone may be methyl farnesoate. A zero discharge aquaculture system is also described.

WO 2006/032099 A2

AQUACULTURE METHOD AND SYSTEM

Field Of The Invention

The present invention relates to an aquaculture method for growing crustacea or fish for harvest. The present method is especially suitable for growing prawns and shrimp and is also applicable to some fish. The present invention also provides an aquaculture system for growing crustacean or fish.

Background Of The Invention

Demand for seafood is increasing across the world. As a result, the load on fisheries is increasing, leading to lower catches of some species and causing complete collapse in other fisheries.

To counter lower catches of seafood, increased interest is being taken in aquaculture. In aquaculture, aquatic creatures are grown in a body of water until a suitable harvesting size is reached. The aquatic creatures are then harvested. Aquaculture typically requires that the aquatic creatures be constrained to remain within a particular area. For example, ocean-going fish may be grown in a netted or caged enclosure positioned in the sea. Prawns (also called shrimp in parts of the world) are frequently grown in ponds located near the coast or near coastal rivers.

Although aquaculture promises to increase the harvest of aquatic creatures, aquaculture does have several disadvantages. These include increased prevalence of parasites in aquaculture, increased disease rates (both bacterial and viral) and increased levels of pollution and nutrient enhancement of water.

Growing prawns in aquaculture systems is a developing industry in Australia. Typical aquaculture systems for growing prawns in Australia involve excavating ponds near the coast or coastal rivers and filling those ponds with water from the sea and coastal rivers. As the prawns grow, uneaten food and excrement collect in the pond. In order to maintain good quality water for prawn growth, early prawn aquaculture systems removed some water from the pond and replaced it with water from the sea or coastal river. As will be appreciated, the water removed from the pond was high in nutrients and turbidity. Thus, disposal of this water caused environmental difficulties.

As environmental regulations become tighter, operating licences for prawn

and fish farms have increasingly stringent requirements for the discharge of effluent waters. In an effort to meet those requirements, trials have started in which water from the ponds is removed, subjected to water treatment to bring the water quality back to an acceptable level and subsequently returned to the pond. The water
5 treatment steps that the water removed from the pond passes through are typically designed to remove nutrients (particularly phosphates and nitrates). These aquaculture systems are known as "recirculating systems". It is readily apparent that an ideal recirculating system would have zero effluent discharge and only require top-up water to replace evaporative losses.

10 Although recirculating systems have been trialed for commercial production of native species of prawns in Australia, to date there has been no real success with such systems. Indeed, experience has shown that growing tiger prawns in recirculating systems sees tiger prawns stop growing when they reach about 14-15g in weight. In contrast, a fully grown tiger prawn should weigh around 30g. There are
15 several possible reasons why successful recirculation has not been demonstrated. Some anecdotal suggest that trace elements found naturally in seawater are quickly utilised by the prawns. Others suggest that native prawns do not favour nutrient rich waters associated until current recirculation technologies.

United States patent no. 6,584,935 in the name of Zohar et al. describes
20 aquaculture systems and processes, particularly for producing an optimal output of a crab species. A particular embodiment of the aquaculture system described in this patent is a recirculated aquaculture system that typically comprises an assembly of tanks each containing an aqueous medium for a specific stage of the aquaculture process (brood stock conditioning, spawning, egg incubation, larval rearing, nursery
25 rearing and grow out), with ancillary solids removal filters, bio filters having associated active microbial communities, oxygen (or oxygen-containing gas) sources, and automatic control units for monitoring and control of oxygen, salinity, temperature, photo exposure, pH and carbon dioxide in respective tanks of the aquaculture process system. The aquaculture system may also include optional
30 ancillary facilities such as ozonation/disinfection units, foam fractionation units, brine generator units, automatic feeder units, biopsy facilities, harvesting/packaging facilities, etc.

The aquaculture process and system of US 6,584,935 is stated to permit continuous culturing of a crab species in a high-rate growth operation to produce crabs of market size in a compressed time frame, relative to conventional marine-farming operations.

5 United States patent no. 5,161,481 to Laufer describes methods and compositions for use in crustacean aquaculture. The method of this patent involves increasing the production of viable larvae by female crustaceans in aquaculture by administering an effective amount of a compound having juvenile hormone activity to the crustaceans. The compound having juvenile hormone activity may be
10 administered to the crustacean orally (e.g. by incorporating the compound into the feedstock) topically (e.g. by dipping the female crustaceans in a relatively concentrated solution of the desired juvenile hormone) or by injection. Specific juvenile hormones named in this patent as being suitable for use in increasing larval production are methyl farnesoate; farnesoic acid; juvenile hormone I; juvenile
15 hormone II; juvenile hormone III; 8, 11, 14 eicosatrienoic acid; methoprene; hydroxyphen; pyriproxyfen and fenoxycarb. This patent also describes juvenile hormones as a family of sesquiterpenoid compounds that regulate both metamorphosis and gametogenesis in insects. The genus comprising juvenile hormone is described in US 5, 161, 481 as including any compound which, when applied to an insect cuticle,
20 prevents that portion of the cuticle to which it was applied from developing from pupa to adult. This patent states that many such compounds are known to those skilled in the art. In fact, the number of such compounds known probably exceeds one hundred and many more could be discovered by a simple assay in which a solution containing compound to be tested is applied to a cuticle of an insect and its effect on
25 development observed.

A number of fish species also show stunting of growth at the first sign of overcrowding. Such fish include Atlantic salmon, kingfish, cobia, mahi mahi, and some species of reef fish. Such fish currently can only be farmed in cages in the open ocean and are not currently suitable for farming in pond or recirculated systems.
30 Similarly, some estuarine and billabong fish, such as barramundi, are also not suited to intensive farming in fish ponds as their growth is stunted in such conditions.

The applicant does not concede that the prior art described in this

specification forms part of the common general knowledge.

The term “comprising” or its grammatical equivalents, when used in this specification, shall be taken to have an inclusive meaning unless its context determines otherwise.

5

Brief Description Of Invention

In a first aspect the present invention provides an aquaculture method for growing crustaceans or fish for harvest in which crustaceans or fish are placed in a discrete body of water, characterised in that the water is treated to reduce a concentration of growth inhibiting compound therein.

10

Throughout this specification, the term “growth inhibiting compound” or any reference to compounds that are associated with limiting the growth of organisms, shall be taken to include one or more growth inhibiting hormones or one or more growth inhibiting enzymes or one or more other compounds that inhibit growth or combinations of other hormones or enzymes or compounds which, in an enclosed

15 body of water, produce or enhance effects consistent with one or more growth inhibiting hormones.

15

Throughout this specification, the term “discrete body of water”, is to be taken to mean that water in the body of water is normally prevented from uncontrolled mixing with environmental water such as would happen if the crustaceans or fish

20 would be grown in a netted region or caged region in the open sea or river. Events such as overflow caused by flooding or leakage are not considered to be normal operation of the at least one discrete body of water.

20

Preferably, the water is treated such that the concentration of a growth limiting compound is reduced to below a predetermined level. More preferably, the

25 water is treated such that concentration of growth limiting compound is reduced to essentially zero.

25

In some embodiments of the present invention, the growth limiting compound is one or more growth limiting hormones.

30

In one embodiment, the method is used to grow crustaceans and the growth inhibiting hormone is methyl farnesoate.

In another embodiment, the growth inhibiting compound comprises two or

more growth limiting hormones or enzymes or other compounds.

In an especially preferred embodiment, the method includes the steps of detecting the presence of one or more growth limiting compounds in the water and treating the water to reduce the concentration of the one or more growth limiting
5 compounds when the presence of the compound(s) is detected. Most suitably, in the growing of crustaceans, the presence of methyl farnesoate is used to indicate the presence of one or more growth limiting compounds in the water and the water is treated to reduce the concentration of methyl farnesoate, thereby reducing the concentration of one or more growth limiting compounds.

10 The presence of the one or more growth limiting compounds in the water may be detected by direct means, such as by direct analysis of the water. Alternatively, the presence of one or more growth limiting compounds may be detected by indirect means. For example, the presence of one or more growth limiting compounds in the water may be inferred when the crustaceans or fish reach a certain
15 size at which observed growth rates slow dramatically or stop. Treatment of the water to reduce the concentration of the one or more growth limiting compounds may be commenced when inspection of the crustaceans or fish indicate that they have reached the certain size.

Preferably, the water is treated to reduce the concentration of growth
20 inhibiting compounds by exposing the water to an oxidizing agent. The oxidizing agent is suitably ozone, although any other oxidizing agent that is non toxic to the organisms may also be used.

In embodiments where ozone is used to treat the water, the dosage rate will be dependant on one or more of the following variables:

- 25 the organism/animal being cultured;
the stage of maturity;
the biomass present; and
the rate of water recirculation through the system.

The dosage rate for ozone may fall within the range of .5 to 20mg/L, more
30 suitably from 1 to 10 mg/L, even more suitably from 1 to 5 mg/L. Through the initial stages of growth, the dosage may be relatively low as very little growth limiting hormone/compound will be present. Dosage with ozone may not even be required in

the early stages. However as the animals increase in size and approach sexual maturity, the required ozone dosage will increase substantially to depress the levels of hormone chemicals in the culture water. It will be understood that each system will require different dosage levels based on the variables listed above.

5 When the present invention is used to grow crustaceans, the crustaceans are preferably prawns or shrimps. Examples of crustaceans that may be grown using the present invention include Black Tiger Prawns (*Penaeus Monodon* all *Penaeus spp.* and *Metapenaeus spp.*, and other species of prawns or shrimps, crab species such as the Blue Swimmer Crab (*Portunus pelagicus*), the mud crab (*Scylla serrata*), and lobster /
10 crayfish species and all other crustaceans.

 When the present invention is used to grow fish, the fish may include species such as Atlantic salmon, kingfish, cobia, mahi mahi, reef fish, barramundi, estuarine fish and billabong fish. This list is not limiting and the present invention may be used to rear many other fish species.

15 In a second aspect, the present invention provides a zero discharge aquaculture method in which crustaceans or fish are grown in a discrete body of water, the method comprising the steps of supplying crustaceans or fish to a body of water to allow the crustaceans or fish to grow to a size suitable for harvest, passing water from the body of water to a treatment zone, treating the water in the treatment
20 zone to reduce a concentration of one or more growth limiting compounds and returning the treated water to the body of water.

 The method of the first and second aspects of the present invention may further include other water treatment steps, for example, to control pH, to control nutrient levels (especially nitrates and phosphates), to control turbidity and to
25 oxygenate the water. Conventional known treatments may be used to achieve these further water treatment steps. For example, pH may be controlled by monitoring the pH and adding either an acid or an alkali to control the pH to a desired pH level. The level of nitrates may be controlled by use of appropriate bacterial treatments to denitrify the water. The level of phosphates may be controlled by adding appropriate
30 phosphate precipitating agents to the water and removing the solid phosphate containing precipitates from the water. Turbidity may be controlled by removing turbidity forming particles from the water. This step may require the use of

floculants to achieve. Oxygenating the water may be achieved by aerating the water in any known manner.

Although preferred embodiments of the method of the present invention reduce the concentration of one or more growth limiting compounds by contacting the water with an oxidizing agent, it will be appreciated that any other treatment that
5 reduces that level of growth limiting compounds may also be used. For example, the water may be contacted with an adsorbent that adsorbs one or more growth limiting compounds from the water. In this embodiment, the water is suitably passed through a packed bed of the adsorbent. Alternatively, the adsorbent may be dispersed into the
10 body of water.

The method of the present invention can provide a zero discharge aquaculture method in which the water in which the crustaceans or fish are growing is treated to maintain a healthy growing environment without the need to discharge the water and subsequently top up with fresh water to maintain a healthy growing environment. As
15 the method can provide a zero discharge aquaculture method, the discharge of polluted water or nutrient rich water from the aquaculture farm is avoided, thereby minimising the environmental impact of the aquaculture farm. It will be appreciated that it may be necessary to supply top-up water to the aquaculture farm in order to make up for evaporative losses.

20 The present invention also provides an aquaculture system. In a third aspect, the present invention provides an aquaculture system for growing crustaceans or fish for harvest, the aquaculture system comprising at least one discrete body of water and water treatment means for treating water from the at least one body of water to reduce a concentration of growth limiting compound therein.

25 Preferably, the aquaculture system is a zero discharge system in which water from the aquaculture system is not discharged to the environment.

In one embodiment, the water treatment means comprises contacting means for contacting an oxidizing agent with the water to reduce the concentration of one or more growth limiting compounds therein. The contacting means may comprise
30 dispersing means for dispersing the oxidizing agent in the water.

More preferably, the water treatment means comprises an ozone water treatment means in which ozone is contacted with the water to thereby reduce the

concentration of one or more growth limiting compounds in the water. The ozone contacting means may include a contacting chamber through which the water can pass and an ozone generating means for supplying ozone to the chamber.

In one preferred embodiment of the aquaculture system of the present invention the aquaculture system further includes water removal means for removing
5 water from the at least one discrete body of water, the water treatment means treating the water removed from the at least one discrete body of water by the water removal means, and water return means for returning treated water from the water treatment means to the at least one discrete body of water.

10 The water removal means may comprise at least one pipe to remove water from the at least one discrete body of water. One or more pumps may also be provided. In another embodiment, the water removal means may comprise a water removal channel. A flow control gate or valve may be operated to control the flow of water from the body of water to the water removal channel.

15 The water return means may comprise one or more pipes. The one or more pipes may have one or more pumps associated therewith. Alternatively, the water return means may comprise one or more water return channels for returning treated water to the at least one discrete body of water.

The at least one discrete body of water is suitably at least one pond or at least
20 one tank. By "discrete body of water", it is meant that water in the body of water is normally prevented from uncontrolled mixing with environmental water such as would happen if the crustaceans or fish would be grown in a netted region or caged region in the open sea or river. Event such as overflow caused by flooding or leakage are not considered to be normal operation of the at least one discrete body of water.

25 Most suitably, the at least one body of water is at least one pond.

In preferred embodiments of the aquaculture system, the water treatment means further treats the water to control one or more of the following water quality parameters: pH, turbidity, nutrient levels (especially nitrates and phosphates), oxygen levels, trace element levels. Any known systems for controlling these water quality
30 parameters may be included in the system of the present invention.

The method and system of the present invention has been based upon the surprising discovery that, of the numerous hormones secreted by crustaceans or fish,

one or more of those hormones can accumulate in the water in which the crustaceans or fish are growing and adversely inhibit the growth of the crustaceans or fish. As mentioned in the background to the invention, previous efforts to grow prawns in Australia using recirculating technology have resulted in the prawns reaching a maximum size that is well below maximum size that such prawns can grow to in the wild or in open discharge aquaculture systems. It had previously been thought that the recirculating technology resulted in a concentration of nutrients in the water, which limited the size to which the prawns could grow. Thus, current recirculation technologies attempted to address control of nutrients in the water.

10 In contrast, the present inventors looked at the problem from a very different perspective. The present inventors postulated that recirculating the water resulted in hormones, enzymes or other compounds secreted by the prawns or other crustaceans or fish being concentrated to a level where the presence of the hormones, enzymes or other compounds in the water had an adverse effect on the growth of the prawns or other crustaceans or fish. Thus, the present inventors postulated that treating the water to reduce the level of hormones, enzymes or other compounds would remove this constraint on growth.

For rearing of crustaceans, the present inventors targeted methyl farnesoate as one of the possible hormones that causes growth inhibition when it reaches certain concentration in the water and thus the method and system of the invention, in preferred embodiments for rearing crustaceans, is targeted towards reducing the concentration of methyl farnesoate. The present inventors without wishing to be bound by theory, have postulated that even if methyl farnesoate is not the compound responsible for growth limitations in the crustaceans, treating the water to control the level of methyl farnesoate will also result in the level of other (unspecified) compounds, such as hormones, that may affect the growth of the crustaceans also being controlled. In other words, if methyl farnesoate is not the hormone that causes a restriction on the growth of the crustaceans, it is a marker hormone for the presence of one or more other hormones or other compounds that do control the growth of the crustaceans. Thus, treating the water to reduce the concentration of methyl farnesoate is also postulated to reduce the level of any other hormones or compounds in the water that may effect the growth of the crustaceans.

- 10 -

The hormone or hormones or other compounds responsible for growth inhibition in fish rearing has not yet been identified, or at least has not been able to be determined by the inventors. However, the present inventors have found that treating the water to reduce the levels of fish hormones in the water results in enhanced growth of the fish. It is postulated that treating the water in accordance with the present invention reduces the levels of growth inhibitory fish hormones, enzymes or other compounds in the water, thereby allowing enhanced fish growth.

Brief Description Of Drawings

Preferred embodiments of the present invention will now be described with reference to the following drawings in which:

FIG 1 shows a schematic plan view of an aquaculture system and method in accordance with the present invention; and

FIG 2 shows a schematic plan view of an alternative embodiment of an aquaculture method and system in accordance with the present invention.

Detailed Description Of The Drawings

It will be appreciated that the drawings accompanying this specification have been provided for the purpose of illustrating the present invention. It is to be understood that the present invention should not be considered to be restricted to the features shown in those preferred embodiments as illustrated in the drawings.

The description of Figures 1 and 2 relates specifically to the growth and harvesting of prawns. However, it will be appreciated that the present invention is applicable to the growth and harvesting of other crustaceans and fish and that the present invention should not be limited to the growth and harvesting of prawns.

In FIG 1, a pond 10 is filled with water and stocked with prawns. A contacting chamber 12 is provided external to the pond 10. Contacting chamber 12 enables water removed from the pond 10 via pipe 14 to be contacted with ozone in order to reduce the concentration of hormones in the water. The treated water leaving the contacting chamber 12 is passed by a pipe 16 back to the pond 10. Pump 18 is used to facilitate return of the water via pump 16 to the pond 10. It will be appreciated that the pipe 14 may also be provided with a pump, if desired, in order to

remove the water from the pond 10.

As will be appreciated from FIG 1, the inlet for water removal pipe 14 is located away from the outlet water pipe 16. As a result, a gentle flow is established in pond 10, with this gentle flow being indicated by broken arrows 20 and 22. This
5 assists in ensuring that all of the water in pond 10 is treated in the contact chamber 12.

FIG 2 shows an alternative embodiment of the present invention in which two ponds 30, 32 are connected via respective water removal pipes 34, 36 to a contacting chamber 38. In contacting chamber 38, water removed from pond 30 and water removed from pond 32 is contact with ozone in order to reduce the
10 concentration of one or more hormones in the water. Treated water passes from the contacting chamber 38 via return pipe 40. The treated water from return pipe 40 then passes along return pipes 42 and 44 to be returned to respective ponds 30 and 32. As with the embodiment shown in FIG 1, a gentle flow is established in ponds 30 and 32.

In order to demonstrate the present invention a small scale farm trial
15 was conducted. The proposed methodology for the field trial involved the setting up of a small-scale model production pond on a commercial prawn farm. The trial utilised an existing, hothouse, nursery pond (area = 236m² floor area) on the commercial farm. Settlement/treatment was of similar area and utilised an adjacent, uncovered, nursery pond.

20 A treatment process was successfully installed to allow treatment and recirculation of growout water. The treatment process included ozone contacting to reduce the concentration of hormone(s) in the water.

Stocking was with 15 to 17g *P. monodon* prawns at a rate equivalent to 10t/Ha @25g (allowing for 10% mortality).

25 In this system, zero water was released throughout the trial. Prawns increased in size from stocking to an average of approximately 28g. Mortalities were low until shortly before the project was terminated, upon which approximately 75% mortality was noted due to equipment failure.

This small scale trial showed that growth of large prawns was possible
30 in a prawn aquaculture system that utilised full water recirculation and zero water discharge.

Similar water treatment systems used in growing fish should also

produce improved sizes for aquaculture methods and systems used to grow fish. For example, Mahi mahi grown in heavily stocked ponds may reach a size of around 3 kg in 2 years, whereas in the wild Mahi Mahi can grow to 20 kg in the same time period. The present invention is expected to be especially beneficial to the aquaculture of fish species that are particularly susceptible to stunting in the presence of overcrowding, as it is postulated that such fish are susceptible to the presence of growth inhibitory hormones in the water. Such fish include Atlantic salmon, kingfish, Cobia, Mahi Mahi, and reef fish. Presently, these fish are only farmed in sea cages at present. Farming of billabong and estuarine fish, such as barramundi, will also benefit from the present invention.

Those skilled in the area will appreciate that the present invention may be subject to variations and modifications other than those specifically described. It is to be understood that the present invention encompasses all such variations and modifications that fall within its spirit and scope.

15

Claims:

1. An aquaculture method for growing crustaceans or fish for harvest in which crustaceans or fish are placed in a discrete body of water, characterised in that the water is treated to reduce a concentration of growth inhibiting compound therein.
- 5 2. A method as claimed in claim 1 wherein the water is treated such that the concentration of a growth limiting compound in the discrete body of water is reduced to below a predetermined level.
3. A method as claimed in claim 2 wherein the water in the discrete body of water is treated such that a concentration of growth limiting compound is reduced to
10 essentially zero.
4. A method as claimed in any one of claims 1 to 3 wherein the growth inhibiting compound comprises two or more growth limiting compounds.
5. A method as claimed in any one of the preceding claims wherein the method includes the steps of detecting the presence of one or more growth limiting
15 compounds in the water and treating the water to reduce the concentration of the one or more growth limiting compounds when the presence of the hormones is detected.
6. A method as claimed in claim 5 wherein the presence of the one or more growth limiting compounds in the water is detected by direct means or detected by
20 indirect means.
7. A method as claimed in any one of the preceding claims wherein the water is treated to reduce to the concentration of growth inhibiting compounds by exposing the water to an oxidizing agent.
8. A method as claimed in claim 7 wherein the oxidizing agent is ozone.
- 25 9. A zero discharge aquaculture method in which crustaceans or fish are grown in a discrete body of water, the method comprising the steps of supplying crustaceans or fish to a body of water to allow the crustaceans or fish to grow to a size suitable for harvest, passing water from the body of water to a treatment zone, treating the water in the treatment zone to reduce a concentration of one or more growth
30 limiting compounds and returning the treated water to the body of water.
10. A method as claimed in any one of the preceding claims further including treating the water to control one or more of pH, nutrient levels (especially nitrates and

- 14 -

phosphates), and turbidity or to oxygenate the water.

11. A method as claimed in any one of the preceding claims wherein the method is used to grow crustaceans and the growth inhibiting compound is methyl farnesoate.
- 5 12. A method as claimed in any one of claims 1 to 10 wherein method is used to grow crustaceans and the presence of methyl farnesoate is used to indicate the presence of one or more growth limiting compounds in the water and the water is treated to reduce the concentration of methyl farnesoate, thereby reducing the concentration of one or more growth limiting compounds.
- 10 13. A method as claimed in any one of the preceding claims wherein the method provides a zero discharge aquaculture method in which the water in which the crustaceans or fish are growing is treated to maintain a healthy growing environment without the need to discharge the water and subsequently top up with fresh water to maintain a healthy growing environment.
- 15 14. An aquaculture system for growing crustaceans or fish for harvest, the aquaculture system comprising at least one discrete body of water and water treatment means for treating water from the at least one body of water to reduce a concentration of growth limiting compound therein.
- 20 15. A system as claimed in claim 14 wherein the aquaculture system is a zero discharge system in which water from the aquaculture system is not discharged to the environment.
16. A system as claimed in claim 14 or claim 15 wherein the water treatment means comprises contacting means for contacting an oxidizing agent with the water to reduce the concentration of one or more growth limiting compounds therein.
- 25 17. A system as claimed in claim 16 wherein the water treatment means comprises an ozone water treatment means in which ozone is contacted with the water to thereby reduce the concentration of one or more growth limiting compounds in the water.
- 30 18. A system as claimed in any one of claims 14 to 17 wherein the system further includes water removal means for removing water from the at least one discrete body of water, the water treatment means treating the water removed from the at least one discrete body of water by the water removal means, and water return

means for returning treated water from the water treatment means to the at least one discrete body of water.

19. A system as claimed in any one of claims 14 to 18 wherein the water treatment means further treats the water to control one or more of the following water quality parameters: pH, turbidity, nutrient levels (especially nitrates and phosphates), oxygen levels, and trace element levels.
20. A method as claimed in any one of claims 1 to 13 wherein the growth limiting compound is one or more growth limiting hormones.
21. A system as claimed in any one of claims 14 to 19 wherein the growth limiting compound is one or more growth limiting hormones.

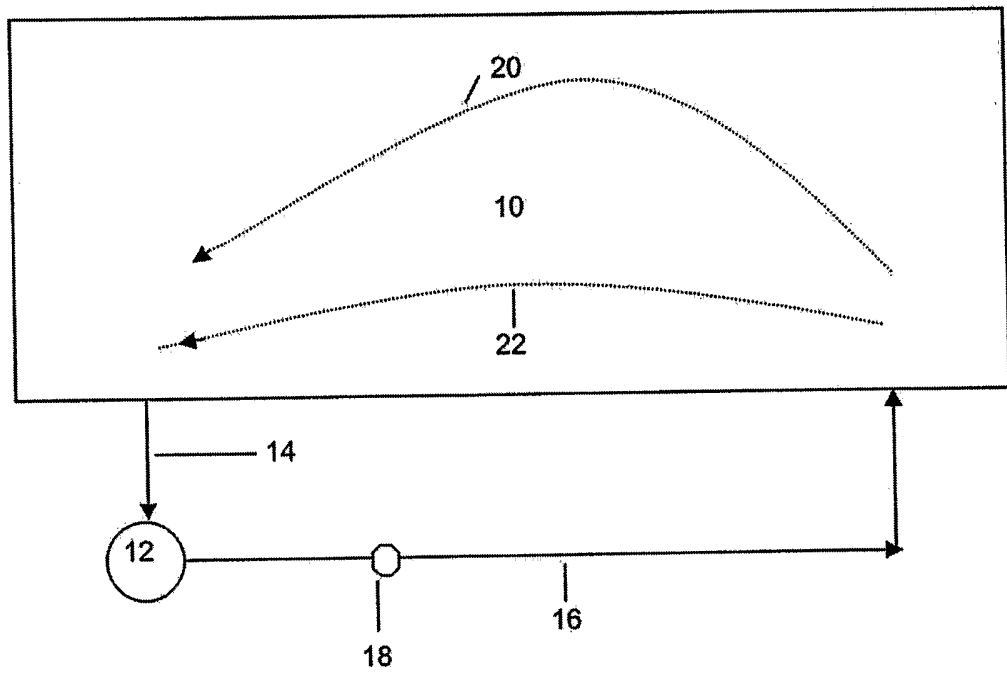

FIGURE 1

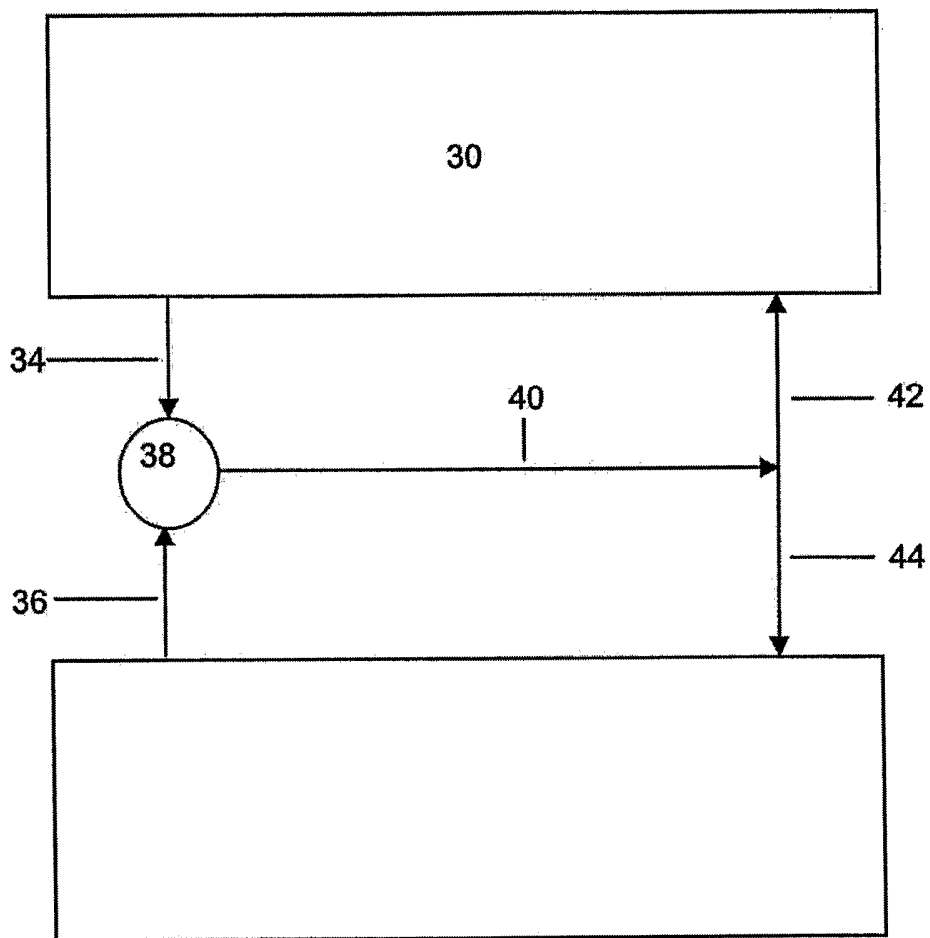

FIGURE 2