

(21) Application No 8208494
(22) Date of filing 23 Mar 1982
(43) Application published
29 Feb 1984

(51) INT CL³
F01D 25/14

(52) Domestic classification
F1T 3A2
F1G 6

(56) Documents cited
GBA 2081871
GBA 2054054
GBA 2016606

(58) Field of search
F1T
F1G

(71) Applicant
Rolls-Royce Limited
(United Kingdom),
65 Buckingham Gate,
London SW1E 6AT

(72) Inventors
David Anthony
Richardson,
Michael Harvey Coney

(74) Agent and/or Address for
Service
G. T. Kelvie,
Company Patents and
Licensing Dept., Rolls-
Royce Limited, P.O. Box
31, Moor Lane, Derby
DE2 8BJ

(54) **Coated gas contacting skin
shroud assembly for a gas turbine
engine**

(57) A shroud assembly (20) for a gas turbine engine consists of a housing (22) having a boundary wall (24) and a gas contacting skin (28), the wall and skin being in segmented form. The skin consists of a thin metal sheet (38) attached to the boundary wall,

and a ceramic gas contacting coating (40). The skin is impingement cooled by cooling air flowing through apertures (32) in the boundary wall, and the cooling air exhausts into the gas flow through passages (34).

The use of a thin metal sheet with a ceramic coating promotes favourable temperature gradients in the skin (28) enabling the coating to run at optimum conditions for maximum cooling effect.

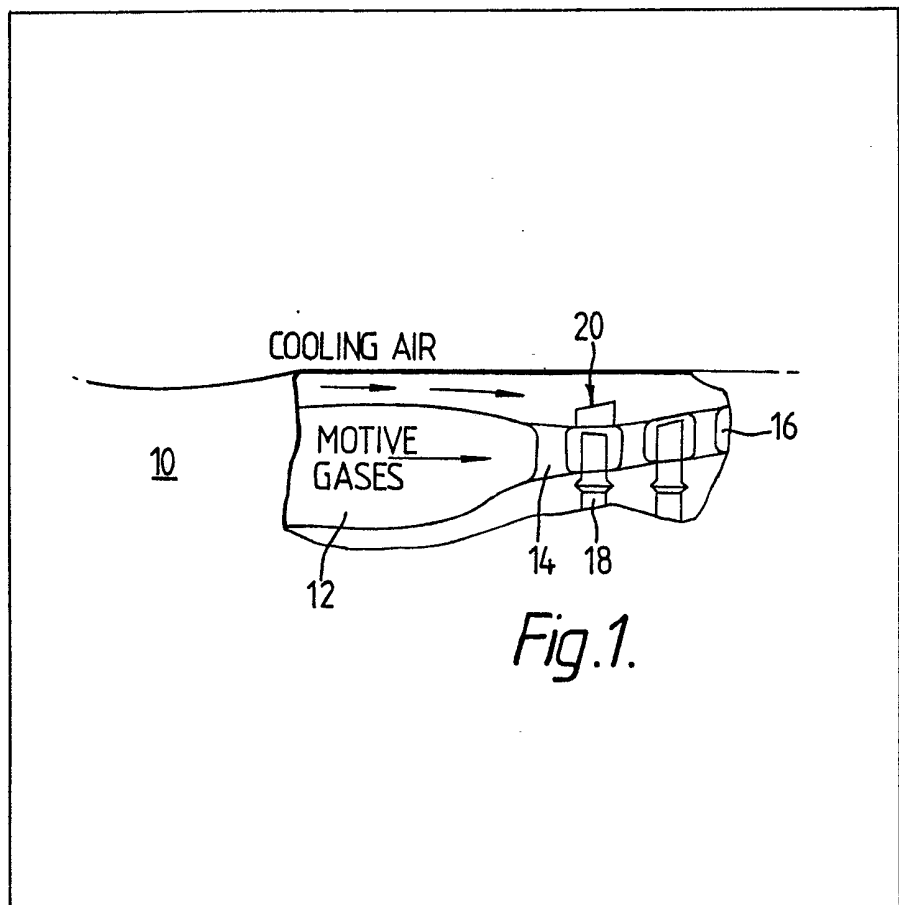

1/1

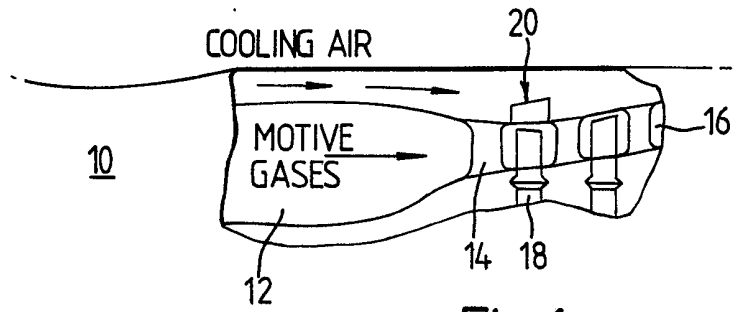

Fig. 1.

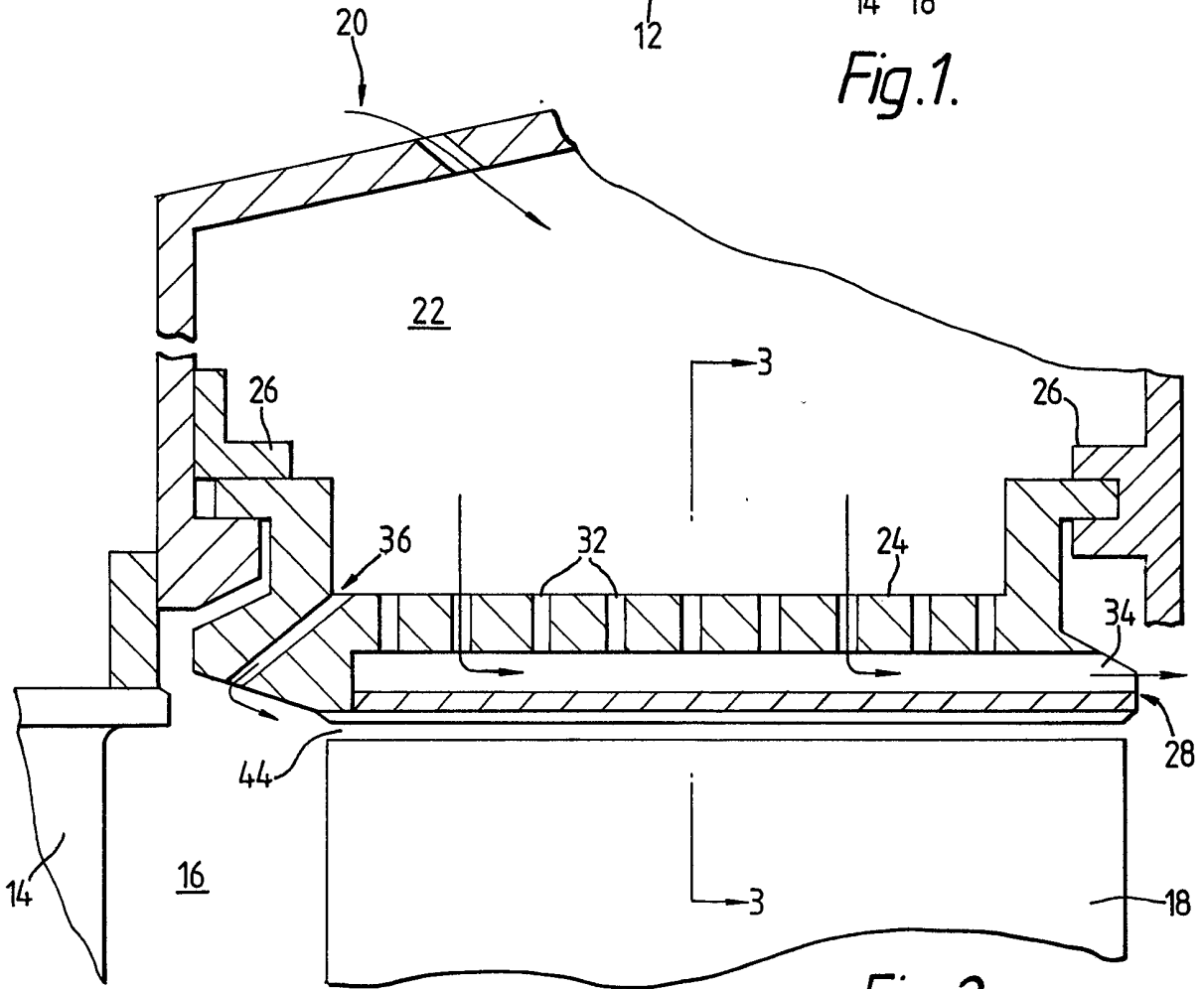

Fig. 2.

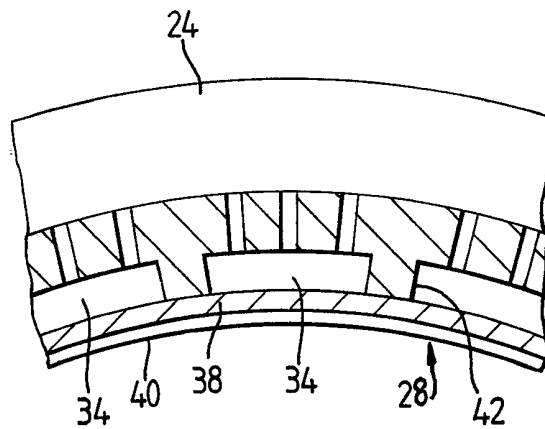

Fig. 3.

SPECIFICATION

Shroud assembly for a gas turbine engine

This invention relates to shroud assemblies for gas turbine engines and is more particularly
 5 concerned with shroud assemblies for the turbine or turbines of such engines.

The trend for improving gas turbine engine performance in terms of power output and efficiency continues. A well established method of
 10 performance improvement involves increasing the temperature of the motive gases, which in turn requires that special attention be paid to those components which are contacted by these gases. For example, the blades and vanes of the engine
 15 turbine and the walls which define the gas path may need a supply of cooling air, or they may need to be made of a particular material or to be of a particular structural form, or they may need to have a combination of any of these features.

20 In the case of turbine shroud assemblies, such assemblies need to maintain a small clearance between the shroud and the rotating turbine at all operating conditions in order to keep turbine efficiency at a maximum. A general form of design
 25 which provides for the cooling of the hot gas contacting part of the shroud and enables the shroud to respond to keep the shroud and turbine clearance to a minimum, involves the use of a plenum chamber, a temperature controlling flow
 30 of air and a gas contacting shroud portion. The shroud assembly is constructed and supported so as to have thermal response characteristics which are similar to those of the turbine, and the plenum chamber is arranged to receive a flowing of
 35 cooling air to discharge the cooling air to cool the gas contacting part of the shroud. The cooling may be by impingement or by transpiration, and a ceramic coating may be applied to the surface of the gas contacting shroud part.

40 The present invention proposes a shroud assembly of a design similar to that discussed above but modified to provide a number of significant advantages. In particular, the amount
 45 of cooling air required to maintain a specific shroud temperature may be reduced, or the same cooling air flow may be used to reduce the shroud temperature.

Accordingly, the present invention provides a shroud assembly for a gas turbine engine, the
 50 assembly comprising a shroud having a housing arranged to receive a flow of cooling fluid and to discharge the cooling fluid through apertures in a boundary wall of the housing, and a skin which in part defines an annular passage for the
 55 throughflow of motive gases, the outer surface of the skin being in contact with the motive gases and the inner surface of the skin being impinged by the flow of cooling fluid from the shroud housing, the cooling fluid being exhausted
 60 between the boundary wall and the skin adjacent the downstream end of the shroud assembly, the skin being attached to and relatively less stiff than the boundary wall, the skin comprising an inner thin metallic layer and an outer layer of ceramic

65 coating.

The boundary wall may include a number of ribs to which the skin is attached, the number, size and spacing of the ribs being such as to minimise distortion of the skin under gas and thermal
 70 loading.

The boundary wall may be a casting and the skin may comprise a thermal barrier coating on a metal sheet, e.g. magnesium zirconate or a stabilized zirconia a Nimonic alloy sheet.

75 The boundary wall may also have further cooling air apertures which discharge cooling air into the motive gas flow at the upstream end of the wall.

In one embodiment, the boundary wall and the
 80 respective skins are formed as a number of arcuate segments which are butted together and held by securing means to form a ring.

The present invention will now be more particularly described with reference to the
 85 accompanying drawing in which:

Fig. 1 shows diagrammatically, a part of a gas turbine engine incorporating a shroud assembly according to the present invention,

90 Fig. 2 is a sectional elevation of the shroud assembly of fig. 1 to a larger scale, and

Fig. 3 is a section on line 3—3 in fig. 2.

Referring to the figures a gas turbine engine 10, only a part of which is shown, includes a combustor 12 discharging motive gases *via* a ring
 95 of nozzle guide vanes 14 into an annular passage 16 which contains a high pressure turbine 18. A shroud assembly 20 surrounds the turbine 18 with a small running clearance being provided between the tips of the blades of the turbine and the shroud assembly. A supply of cooling air is taken from the engine compressor to cool the shroud assembly as
 100 will be described below.

The assembly 20 comprises a housing 22 and a boundary wall 24 held in position by securing
 105 means 26 and having a skin 28. The housing receives the cooling air through openings 30 and the cooling air is discharged through apertures 32 to impinge upon the inner face of the skin. The used cooling air is discharged into the gas annulus
 110 16 through passages 34, and if desired, some cooling air may be discharged through openings 36 in the boundary wall at its upstream end.

The skin 28 comprises a layer 38 of metal sheet, e.g. a Nimonic alloy and a thermal barrier
 115 coating 40, e.g. magnesium zirconate or a stabilised zirconia. The skin is attached to longitudinal ribs 42 which are cast integrally with the boundary wall, the number, size and spacing of the ribs being such as to minimise distortion of the
 120 skin when in use.

Although not shown in detail, the boundary wall and skin is divided up into a number of arcuate segments which are butted together and held by the securing means 26 to form a ring
 125 around the turbine 18, with a clearance 44 between the turbine blades and segments.

As compared with known forms of shroud assembly in which the impingement cooling is onto a relatively thick wall, the corresponding wall

of the present invention is the skin 28 which is relatively thin, and which enables the Biot number effects to be exploited, the Biot number being an indication of the ratio of thermal conductance at the surface to the thermal conductivity of a material. The use of a thin metal sheet means that the ceramic coatings employed, are provided with optimum running conditions for maximum cooling effect, because of the favourable temperature gradients in the ceramic and the metal sheet.

The invention enables a smaller flow of cooling air to be used to maintain a particular temperature in the shroud, or the same flow of cooling air can be used to maintain the shroud at a particular temperature if the motive gas temperature is increased.

If blade rub should occur between the blades and the skin, the ceramic coating provides an abradable coating, and in the extreme case of the skin becoming detached, the shroud segment reverts to pure film cooling. The segment can then be repaired fairly easily by brazing on a new skin.

CLAIMS

1. A shroud assembly for a gas turbine engine, the assembly comprising a shroud having a housing arranged to receive a flow of cooling fluid and to discharge the cooling fluid through apertures in a boundary wall of the housing, and a skin which in part defines an annular passage for the throughflow of motive gases, the outer surface of the skin being in contact with the motive gases and the inner surface of the skin being impinged by the flow of cooling fluid from the shroud

housing, the cooling fluid being exhausted between the boundary wall and the skin adjacent the downstream end of the shroud assembly, the skin being attached to and is relatively less stiff than the boundary wall, the skin comprising an inner thin metallic layer and an outer layer of ceramic coating.

2. An assembly as claimed in claim 1 in which the boundary wall includes two or more ribs to which are attached the skin, the spacing of the ribs being such as to keep distortion of the skin to a minimum.

3. An assembly as claimed in claim 1 in which the boundary wall is a casting, the thin inner metallic layer is a sheet and the ceramic coating is a thermal barrier coating.

4. An assembly as claimed in claim 1 in which the boundary wall includes further cooling fluid apertures which are arranged to discharge cooling fluid into the flow of motive fluid upstream of the skin.

5. An assembly as claimed in claim 1 in which the boundary wall and the respective skins are in the form of a number of arcuate segments, the ends of which are butted together to form a ring.

6. A turbine for a gas turbine engine including a bladed rotor and a shroud assembly as claimed in any one of claims 1 to 5, the shroud assembly being spaced outwardly of the bladed rotor and closely spaced therefrom.

7. A shroud assembly for a gas turbine constructed and arranged for use and operation substantially as herein described, and with reference to the accompanying drawing.