

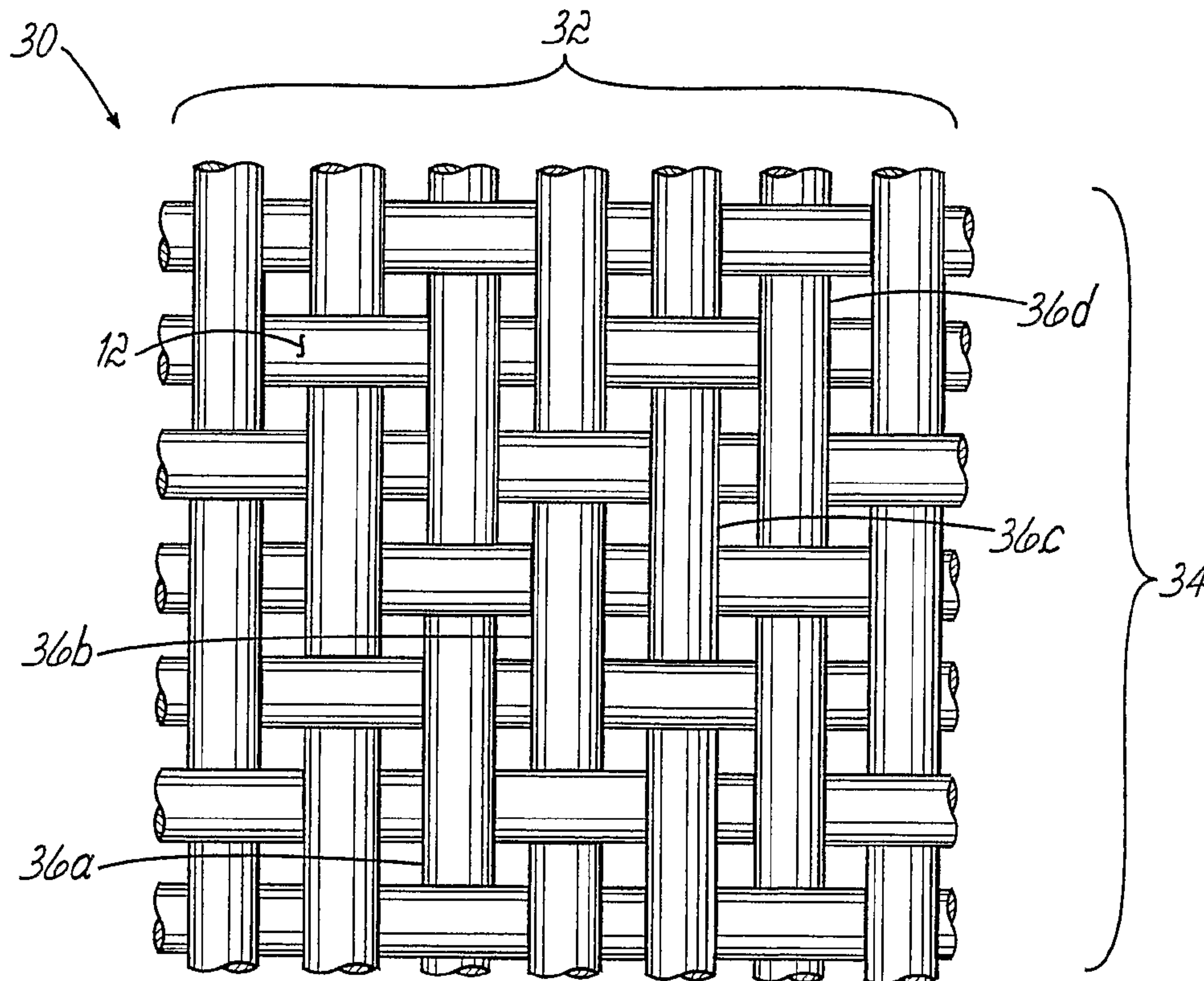

(86) Date de dépôt PCT/PCT Filing Date: 2004/10/12
 (87) Date publication PCT/PCT Publication Date: 2005/05/19
 (45) Date de délivrance/Issue Date: 2008/12/09
 (85) Entrée phase nationale/National Entry: 2006/01/24
 (86) N° demande PCT/PCT Application No.: US 2004/033603
 (87) N° publication PCT/PCT Publication No.: 2005/045111
 (30) Priorité/Priority: 2003/10/29 (US10/696,683)

(51) Cl.Int./Int.Cl. *D03D 15/00* (2006.01)
 (72) Inventeur/Inventor:
HEIMAN, GARY L., US
 (73) Propriétaire/Owner:
STANDARD TEXTILE CO., INC., US
 (74) Agent: MACRAE & CO.

(54) Titre : FEUILLE A GEOMETRIE DE SURFACE AMELIOREE
 (54) Title: ENHANCED SURFACE GEOMETRY SHEETING



(57) **Abrégé/Abstract:**

A woven fabric sheeting (30) includes a plurality of warp yarns (32) and filling yarns (34) woven together in a twill weave pattern, with the sheeting (30) including a plurality of warp yarn floats (36), and the filling including a synthetic filament yarn. Another woven fabric sheeting (40) includes a plurality of warp yarns (42) and filling yarns (44) woven together in a twill weave pattern, with the sheeting (40) including a plurality of filling yarn floats (46), and the warp including a synthetic filament yarn.

(12) INTERNATIONAL APPLICATION PUBLISHED UNDER THE PATENT COOPERATION TREATY (PCT)

(19) World Intellectual Property
Organization
International Bureau



(43) International Publication Date
19 May 2005 (19.05.2005)

PCT

(10) International Publication Number
WO 2005/045111 A1

- (51) International Patent Classification⁷: **D03D 15/00**
- (21) International Application Number:
PCT/US2004/033603
- (22) International Filing Date: 12 October 2004 (12.10.2004)
- (25) Filing Language: English
- (26) Publication Language: English
- (30) Priority Data:
10/696,683 29 October 2003 (29.10.2003) US
- (71) Applicant (for all designated States except US): **STANDARD TEXTILE CO., INC.** [US/US]; One Knollcrest Drive, P.O. Box 371805, Cincinnati, OH 45222-1805 (US).
- (72) Inventor; and
(75) Inventor/Applicant (for US only): **HEIMAN, Gary** [US/US]; 3005 Burning Tree Lane, Cincinnati, OH 45237 (US).
- (74) Agents: **GROSSMAN, Kurt, L.** et al.; Wood, Herron & Evans, L.L.P., 2700 Carew Tower, Cincinnati, OH 45202 (US).
- (81) Designated States (unless otherwise indicated, for every kind of national protection available): AE, AG, AL, AM, AT, AU, AZ, BA, BB, BG, BR, BW, BY, BZ, CA, CH, CN, CO, CR, CU, CZ, DE, DK, DM, DZ, EC, EE, EG, ES, FI, GB, GD, GE, GH, GM, HR, HU, ID, IL, IN, IS, JP, KE, KG, KP, KR, KZ, LC, LK, LR, LS, LT, LU, LV, MA, MD, MG, MK, MN, MW, MX, MZ, NA, NI, NO, NZ, OM, PG, PH, PL, PT, RO, RU, SC, SD, SE, SG, SK, SL, SY, TJ, TM, TN, TR, TT, TZ, UA, UG, US, UZ, VC, VN, YU, ZA, ZM, ZW.
- (84) Designated States (unless otherwise indicated, for every kind of regional protection available): ARIPO (BW, GH, GM, KE, LS, MW, MZ, NA, SD, SL, SZ, TZ, UG, ZM, ZW), Eurasian (AM, AZ, BY, KG, KZ, MD, RU, TJ, TM), European (AT, BE, BG, CH, CY, CZ, DE, DK, EE, ES, FI, FR, GB, GR, HU, IE, IT, LU, MC, NL, PL, PT, RO, SE, SI, SK, TR), OAPI (BF, BJ, CF, CG, CI, CM, GA, GN, GQ, GW, ML, MR, NE, SN, TD, TG).

[Continued on next page]

(54) Title: ENHANCED SURFACE GEOMETRY SHEETING

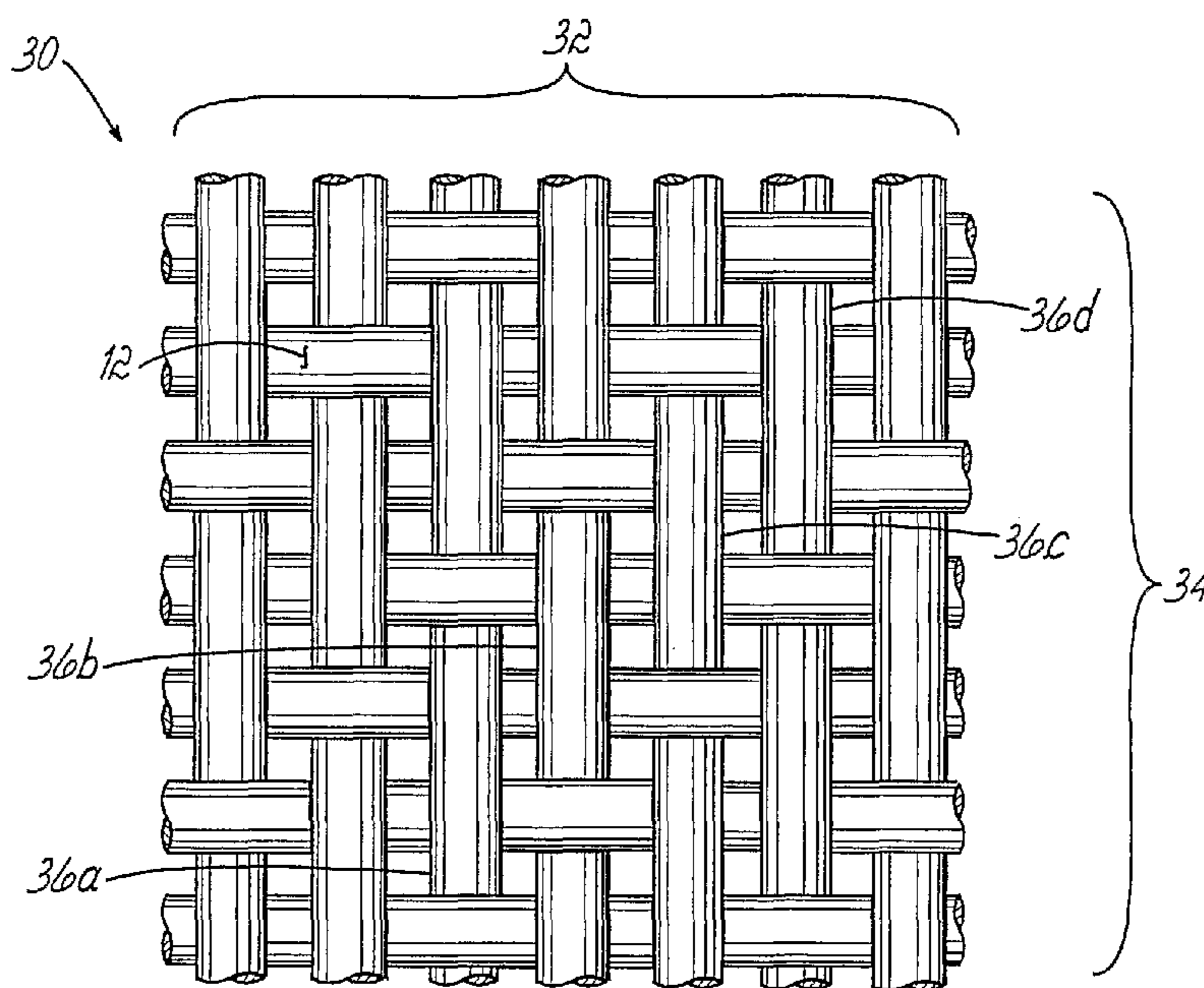

(57) Abstract: A woven fabric sheeting (30) includes a plurality of warp yarns (32) and filling yarns (34) woven together in a twill weave pattern, with the sheeting (30) including a plurality of warp yarn floats (36), and the filling including a synthetic filament yarn. Another woven fabric sheeting (40) includes a plurality of warp yarns (42) and filling yarns (44) woven together in a twill weave pattern, with the sheeting (40) including a plurality of filling yarn floats (46), and the warp including a synthetic filament yarn.

WO 2005/045111 A1

WO 2005/045111 A1



Published:

— *with international search report*

For two-letter codes and other abbreviations, refer to the "Guidance Notes on Codes and Abbreviations" appearing at the beginning of each regular issue of the PCT Gazette.

ENHANCED SURFACE GEOMETRY SHEETING

Background of the Invention

Field of the Invention

[0001] This invention is directed to woven fabric sheeting.

Description of Related Art

[0002] Woven fabric sheeting typically is made of 100% cotton or a combination of cotton and a synthetic material such as, for example, polyester. Sheeting made entirely of cotton usually is quite comfortable to the touch. However, such all-cotton sheeting tends to lack long-term durability. For example, the sheeting may deteriorate at an undesirably fast rate due to yarn damage from normal washing and use. In contrast, sheeting which includes a synthetic material typically has a higher durability. However, this feature comes at the expense of comfort.

[0003] In an effort to combine comfort features of cotton fabrics with durability advantages of synthetic fabrics, U.S. Patent No. 5,495,874 (owned by the assignee of the present invention) proposes a plain woven fabric sheeting constructed of cotton warp yarns and polyester filament filling yarns. However, it would be desirable to make that plain weave fabric more comfortable.

[0004] Thus, further improvements in woven fabric sheeting are desired.

Summary of the Invention

[0005] I have determined that a woven sheeting construction which includes warp yarn floats and a synthetic filament yarn in the filling is sufficient to provide a woven fabric sheeting with improved levels of comfort and durability. Such a construction brings a greater proportion of each of the floated yarns (i.e., the warp yarns) to the surface of the sheeting, which tends to increase surface tactile comfort. Thus, the floated yarns may be said to be "comfort yarns". At the same time, the synthetic filament yarn enhances the durability of the sheeting. In addition, the construction provides differentially elevated and/or depressed areas or designs on the surface of the sheeting, which may create pathways or channels for increased airflow through and/or across the sheeting. This feature not only enhances comfort, but also is believed to have a positive impact on skin care.

[0006] Alternatively, the sheeting may include filling yarn floats and a synthetic filament yarn in the warp. And if desired, the sheeting may include both warp yarn floats and filling yarn floats, with the filling and/or the warp including a synthetic filament yarn. These constructions also achieve the advantages described above.

[0007] The woven fabric sheeting may be characterized by a float pattern, x/y , which is specific to a given warp or filling yarn (and/or to a plurality of warp or filling yarns) as that yarn relates to yarns in the perpendicular direction of the weave. x represents the number of adjacent yarns (at least two) over which a floated yarn extends or "floats", and y represents the number of adjacent yarns (at least one) under which the floated yarn passes. Although not required, a float pattern typically is repeated along the length of a given warp yarn or filling yarn. The portion of the floated yarn which extends over two or more adjacent yarns is referred to as a "float". In general, each of x and y is a whole number greater than zero (0), and x is at least two (2). If a warp or filling yarn does not include floats, then that yarn does not have a float pattern.

[0008] Any of the floated yarns may be formed of natural fibers, synthetic staple fibers, and/or synthetic filaments. Advantageously, the floated yarns are natural yarns, for example, cotton yarns to provide the most desired comfort. At least one of the yarns which is perpendicular (in the weave) to a given floated yarn is formed of synthetic filament, for example, polyester. Advantageously, a plurality of the perpendicular yarns in the sheeting are formed of synthetic filament. If desired, one or more of the perpendicular yarns may be formed of natural fibers and/or synthetic staple fibers.

[0009] The woven fabric sheeting may be constructed using any non-plain weave pattern or combination of such patterns. For example, the sheeting may be formed using a twill weave, a satin weave, a gabardine weave, a herringbone weave, or a combination of such weaves. In addition, any suitable

yarn float pattern may be used. Nonlimiting examples include a 2/1 twill weave pattern, a 2/2 twill weave pattern, and a 4/1 satin weave pattern, although other float patterns and weaves with floated yarns are possible, as will be appreciated by one of ordinary skill in the art.

[0010] By virtue of the foregoing, there is thus provided a woven fabric sheeting having advantages over prior woven fabric sheetings. These and other advantages of the present invention shall be made apparent from the accompanying drawings and description of the drawings.

Brief Description of the Drawings

[0011] The accompanying drawings, which are incorporated in, and constitute a part of this specification, illustrate versions of the invention, and, together with the general description of the invention given above, and the detailed description of versions of the invention given below, serve to explain the principles of the invention.

[0012] Fig. 1 is a perspective view of a woven fabric sheeting in accordance with the principles of the invention;

[0013] Fig. 2 is an enlarged, fragmentary top view, not to scale, of a portion of a woven fabric sheeting in accordance with the principles of the invention; and

[0014] Fig. 3 is an enlarged, fragmentary top view, not to scale, of a portion of another woven fabric sheeting in accordance with the principles of the present invention.

Detailed Description of the Drawings

[0015] With reference to Fig. 1, a woven fabric sheeting 10 includes a first surface 12 and an oppositely-disposed second surface 14, with the surfaces 12, 14 extending between a left selvage 16 and a right selvage 18, as well as a top or trailing end 20 and a bottom or leading end 22.

[0016] With reference to Fig. 2, a woven fabric sheeting 30 includes a plurality of warp yarns 32 and filling yarns 34, with the yarns 32, 34 woven together in a twill weave having a warp yarn float pattern of 2/1. In other words, a series of floats, as at 36a,b,c,d, are staggered in the filling direction, with the floats being formed by the warp yarns 32. As seen in Fig. 2, the 2/1 float pattern simply indicates that each of the warp yarns 32 extends, or "floats", over two adjacent filling yarns, and then passes under a single filling yarn, a pattern which is repeated along the length of each of the warp yarns 32. The warp yarns 32 are natural yarns, for example, cotton yarns; and the filling yarns 34 are multifilament yarns, for example polyester multifilament yarns. Because the warp yarns 32 are floated, a greater proportion of each of the warp yarns 32 is present at the first surface 12 of the sheeting 30. In contrast, the filament filling yarns 34 are not floated, and therefore a lesser proportion of each of these yarns 34 is present at the surface 12. The net effect is an increase in tactile comfort at the surface 12 and an overall enhancement in durability.

[0017] With reference to Fig. 3, a woven fabric sheeting 40 includes a plurality of warp yarns 42 and a plurality of filling yarns 44, with the yarns 42, 44 woven together in a twill weave which includes a plurality of filling yarn floats, as

at 46a,b,c,d, having a float pattern of 2/1. In this particular sheeting 40, the filling yarn floats are staggered in the warp direction. In addition, given the 2/1 float pattern, each of the filling yarns 44 extends (i.e., "floats") over two adjacent warp yarns, and under a single warp yarn, with this pattern being repeated along the length of each of the filling yarns 44. The warp yarns 42 are multifilament yarns, for example, polyester multifilament yarns; and the filling yarns 44 are natural yarns, for example cotton yarns. Because the filling yarns 44 are floated, a greater proportion of each of the yarns 44 is present at the first surface 12 of the sheeting 40. In contrast, the filament warp yarns 42 are not floated, and therefore a lesser proportion of each of these yarns 42 is present at the surface 12. The result is an increase in tactile comfort at the surface 12 and an overall enhancement in durability.

[0018] Each of the woven fabric sheetings described above provides several benefits and advantages. For example, the sheeting offers an enhanced level of comfort and durability. In addition, air is able to pass across or through the sheeting to an extent which not only improves comfort, but also may have a favorable impact on skin care.

[0019] In use, the woven fabric sheeting may be formed into suitable items. For example, any of the sheetings may be formed into sheets, pillow cases, and the like, all of which are both comfortable and durable.

[0020] By virtue of the foregoing, there is thus provided a woven fabric sheeting having advantages over prior woven fabric sheetings.

[0021] While the present invention has been illustrated by the description of versions and specific examples, and while the versions have been described in considerable detail, I do not intend to restrict or in any way limit the scope of the appended claims to such detail. Additional advantages and modifications readily will appear to those skilled in the art. For example, although the drawings illustrate a twill weave, any non-plain weave may be used, with nonlimiting examples including a twill weave, a satin weave, a gabardine weave, a herringbone weave, and combinations of such weaves. And although multifilament yarns are used in the sheeting versions illustrated in Figs. 2 and 3, a woven fabric sheeting may use monofilament yarns — either in place of, or in combination with, multifilament yarns. In addition, while Figs. 2 and 3 depict sheetings having a single float pattern which is maintained throughout the sheeting, as well as floats in only one of the weave (i.e., warp or filling) directions, any suitable float pattern or combination of float patterns may be used — either in a single weave (i.e., warp or filling) direction or in both (i.e., both warp and filling) weave directions. The invention, in its broader aspects, therefore is not limited to the specific details, representative apparatus and methods, and illustrative examples shown and described. Accordingly, departures may be made from such details without departing from the scope or spirit of my general inventive concept.

[0022] Having described the invention, I claim:

CLAIMS

1. A woven fabric sheeting, comprising:
a plurality of warp yarns (32, 42); and
a plurality of filling yarns (34, 44),
the warp yarns (32, 42) and the filling yarns (34, 44) being woven together in a weave pattern,
and at least one of the warp yarns (32, 42) being a spun yarn of natural fibers,
characterized in that the weave pattern includes a plurality of warp yarn floats repeating along substantially the length of respective ones of the warp yarns (32, 42) in an x/y float pattern, wherein each of x and y are whole numbers greater than zero (0), x is at least two (2), and x is greater than y, and in that at least one of the filling yarns (34, 44) is a synthetic multifilament yarn.
2. The sheeting of claim 1 wherein at least one of the warp yarns (32, 42) including a synthetic filament.
3. The sheeting of claim 2 wherein the one of the warp yarns (32, 42) is a synthetic multifilament yarn.
4. The sheeting of claim 1 or claim 3 wherein the synthetic multifilament yarn is formed of polyester.
5. The sheeting of any one of claims 1 to 4 wherein at least one of the filling yarns (34, 44) is a spun yarn.
6. The sheeting of claim 5 wherein the spun yarn includes natural fibers.

7. The sheeting of claim 5 or claim 6 wherein the spun yarn includes synthetic staple fibers.
8. The sheeting of claim 1 wherein at least one of the warp yarns is a spun yarn including synthetic staple fibers.
9. The sheeting of claim 1 wherein each of the filling yarns is a synthetic multifilament yarn and each of the warp yarns is a spun yarn of natural fibers.
10. The sheeting of claim 1 wherein each of the filling yarns is a synthetic multifilament yarn.
11. The sheeting of claim 1 wherein each of the warp yarns is a spun yarn of natural fibers.
12. The sheeting of any one of claims 1 to 11 wherein the sheeting has a warp yarn float pattern of 2/1.
13. The sheeting of any one of claims 1 to 11 wherein the sheeting has a warp yarn float pattern of 3/1.
14. The sheeting of any one of claims 1 to 13 wherein the warp yarns (32, 42) and the filling yarns (34, 44) are woven together in a weave pattern selected from the group consisting of a twill weave, a satin weave, a gabardine weave, a herringbone weave, and combinations thereof.
15. The sheeting of claim 14 wherein the weave pattern is a twill weave.

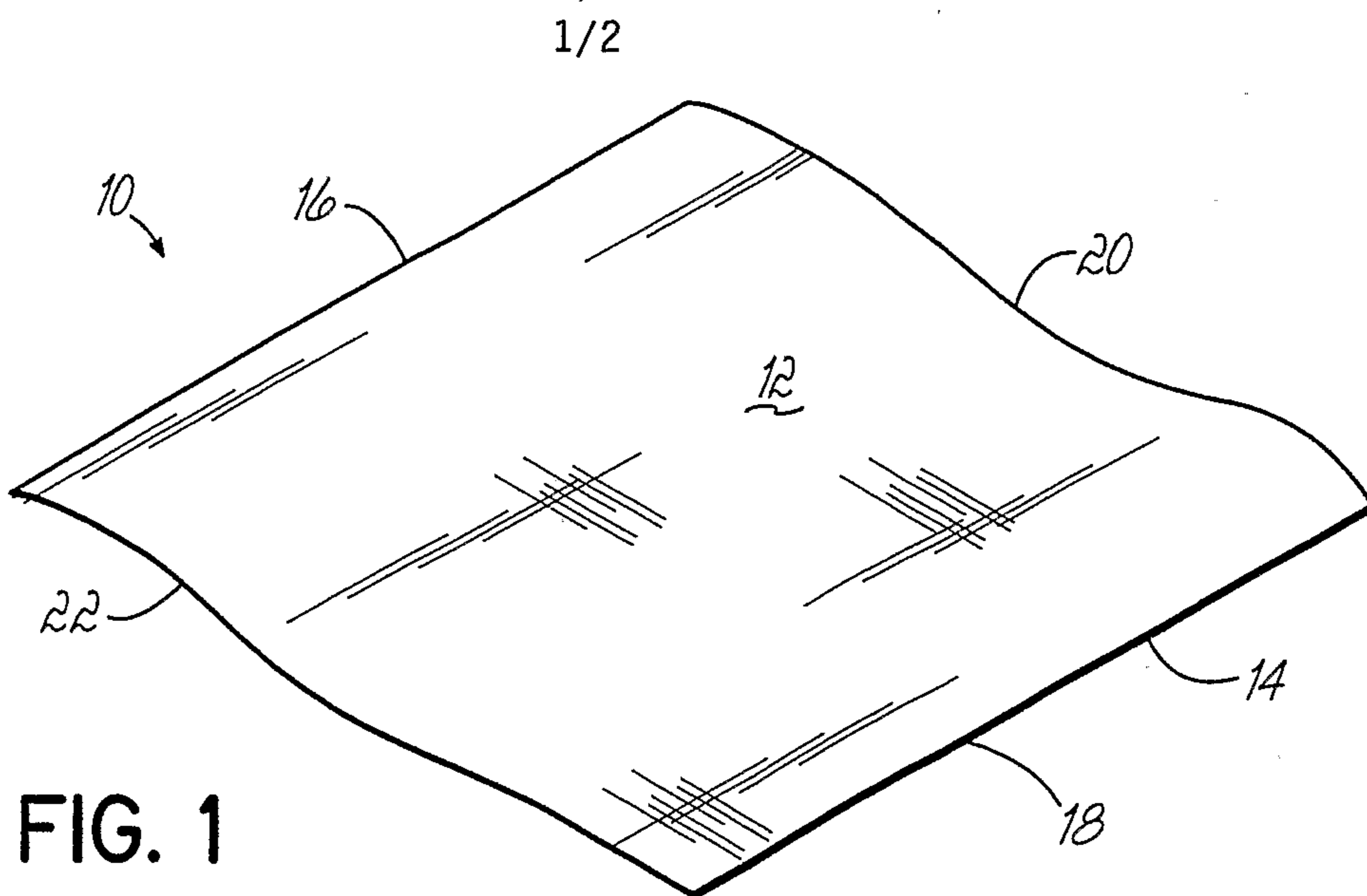

FIG. 1

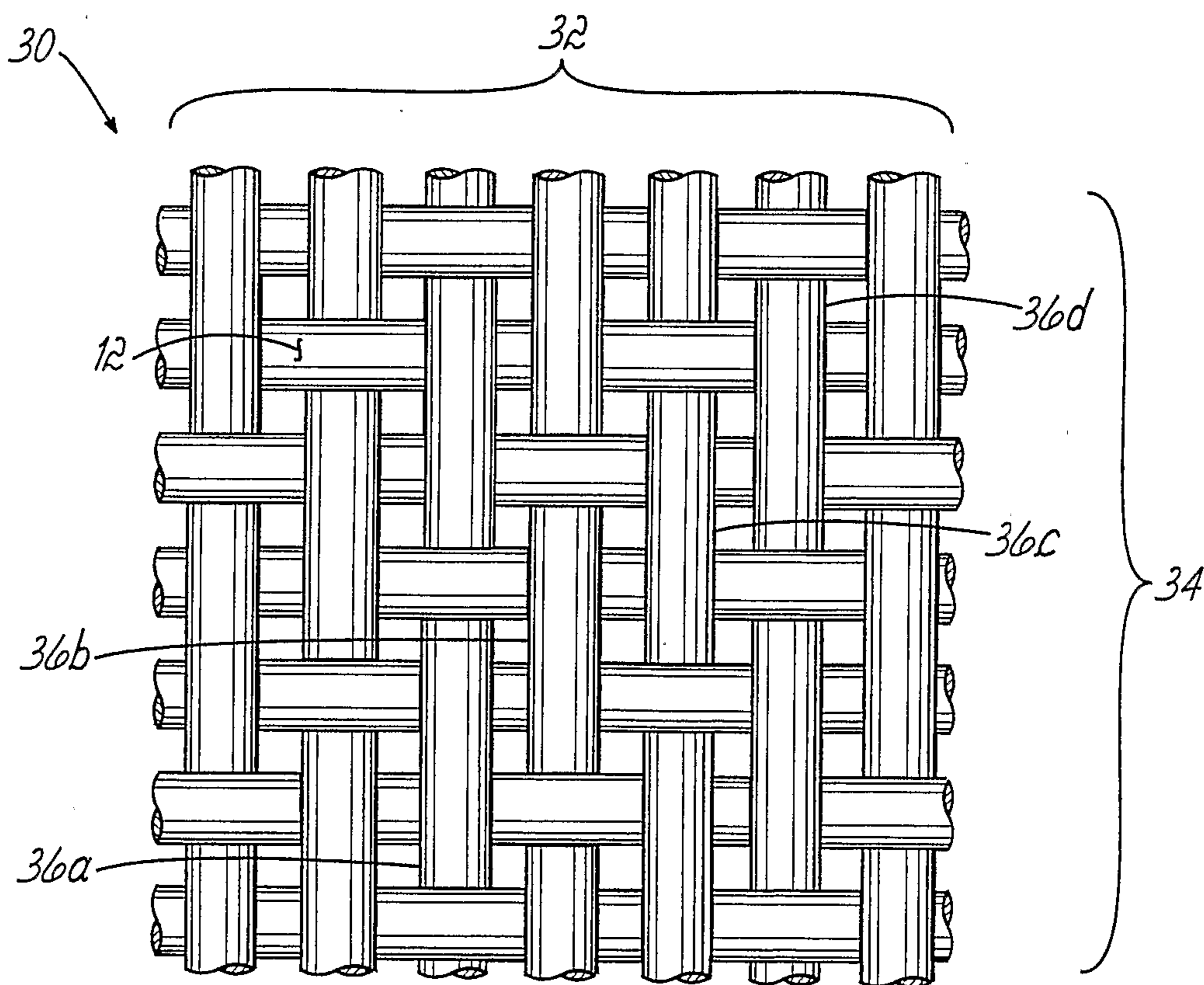

FIG. 2

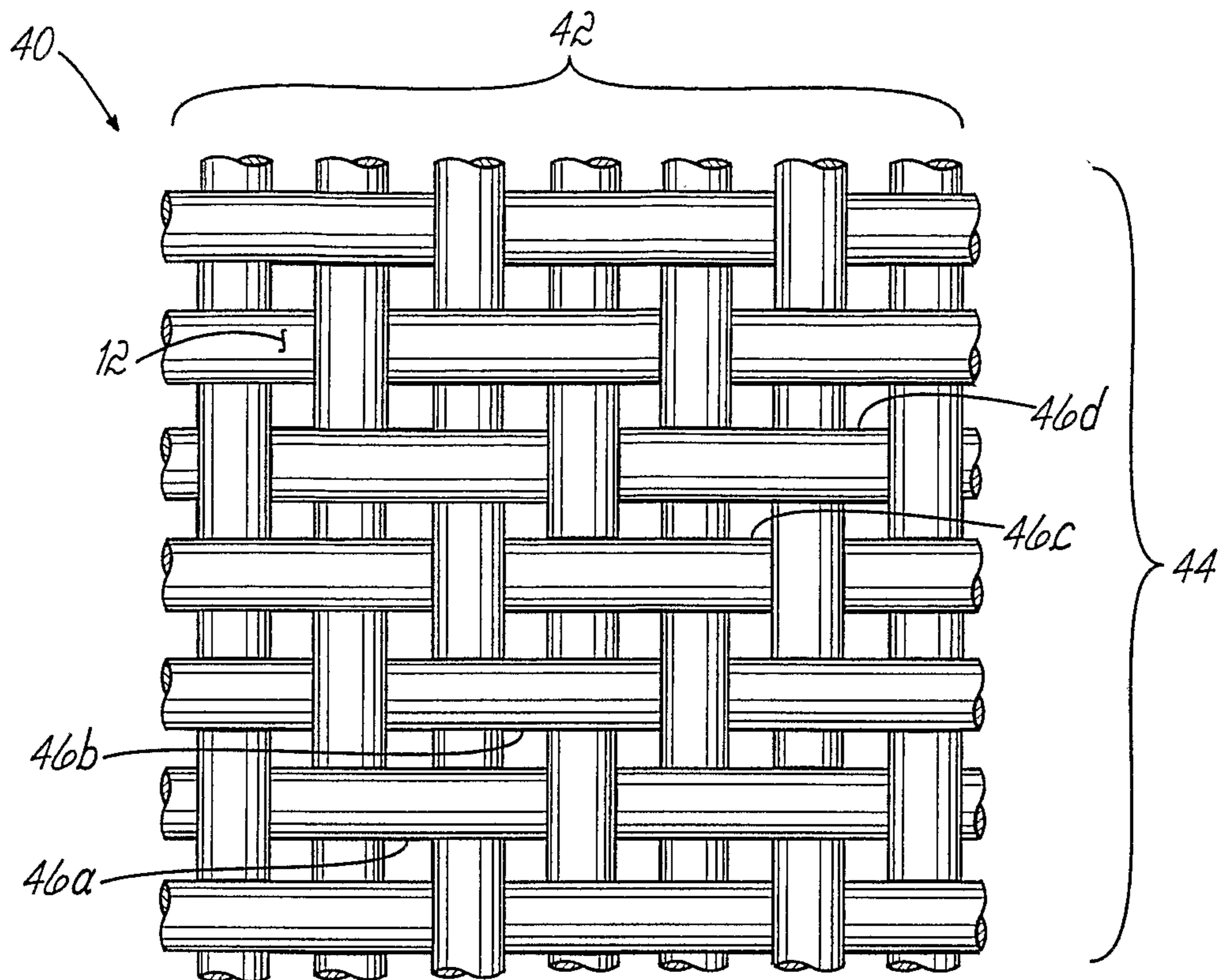

FIG. 3

30

32

12

36d

36c

36b

36a

34

