

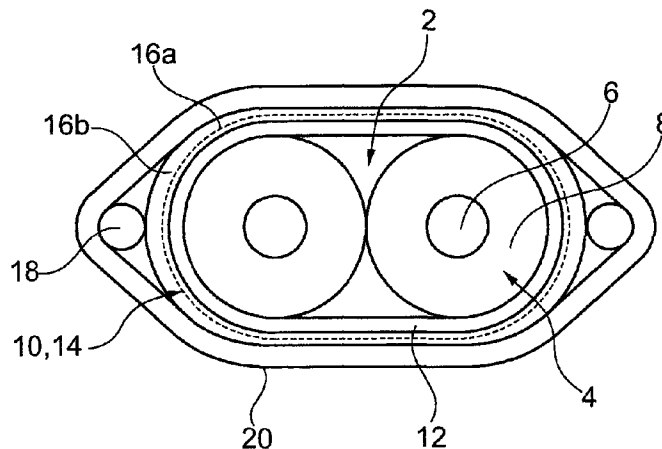

(86) Date de dépôt PCT/PCT Filing Date: 2015/07/01
 (87) Date publication PCT/PCT Publication Date: 2016/01/28
 (45) Date de délivrance/Issue Date: 2020/01/07
 (85) Entrée phase nationale/National Entry: 2017/01/03
 (86) N° demande PCT/PCT Application No.: EP 2015/065034
 (87) N° publication PCT/PCT Publication No.: 2016/012213
 (30) Priorité/Priority: 2014/07/25 (DE10 2014 214 726.3)

(51) Cl.Int./Int.Cl. *H01B 11/06* (2006.01),
H01B 11/20 (2006.01)
 (72) Inventeurs/Inventors:
JANSSEN, BERND, DE;
DETTMER, MELANIE, DE
 (73) Propriétaire/Owner:
LEONI KABEL GMBH, DE
 (74) Agent: MARKS & CLERK

(54) Titre : CABLE DE DONNEES POUR TRANSMISSIONS DE DONNEES A HAUT DEBIT
 (54) Title: DATA CABLE FOR HIGH-SPEED DATA TRANSMISSIONS



(57) **Abrégé/Abstract:**

The data cable (22) for high-speed data transmissions comprises at least one conductor pair (2) that consists of conductors (4) extending in the longitudinal direction (17) and being surrounded by a shielding foil (14) to give a pair shielding unit (10), a dielectric intermediate foil (12), having a varying lay length (l), being spun around the conductor pair (2) between the shielding foil (14) and the conductor pair (2). In this way, a damping peak at high transmission frequencies is effectively avoided.

(12) NACH DEM VERTRAG ÜBER DIE INTERNATIONALE ZUSAMMENARBEIT AUF DEM GEBIET DES PATENTWESENS (PCT) VERÖFFENTLICHTE INTERNATIONALE ANMELDUNG

(19) Weltorganisation für geistiges Eigentum

Internationales Büro

(43) Internationales Veröffentlichungsdatum
28. Januar 2016 (28.01.2016)(10) Internationale Veröffentlichungsnummer
WO 2016/012213 A1

- (51) **Internationale Patentklassifikation:**
H01B 11/00 (2006.01) *H01B 11/20* (2006.01)
- (21) **Internationales Aktenzeichen:** PCT/EP2015/065034
- (22) **Internationales Anmeldedatum:**
1. Juli 2015 (01.07.2015)
- (25) **Einreichungssprache:** Deutsch
- (26) **Veröffentlichungssprache:** Deutsch
- (30) **Angaben zur Priorität:**
10 2014 214 726.3 25. Juli 2014 (25.07.2014) DE
- (71) **Anmelder:** LEONI KABEL HOLDING GMBH
[DE/DE]; Marienstraße 7, 90402 Nürnberg (DE).
- (72) **Erfinder:** JANSSEN, Bernd; Luchsweg 5, 26169 Friesoythe OT Neuscharrel (DE). DETTMER, Melanie; Tulpenstr. 19, 26892 Heede (DE).
- (74) **Anwalt:** FDST PATENTANWÄLTE; Nordostpark 16, 90411 Nürnberg (DE).
- (81) **Bestimmungsstaaten** (soweit nicht anders angegeben, für jede verfügbare nationale Schutzrechtsart): AE, AG, AL, AM, AO, AT, AU, AZ, BA, BB, BG, BH, BN, BR, BW,

BY, BZ, CA, CH, CL, CN, CO, CR, CU, CZ, DE, DK, DM, DO, DZ, EC, EE, EG, ES, FI, GB, GD, GE, GH, GM, GT, HN, HR, HU, ID, IL, IN, IR, IS, JP, KE, KG, KN, KP, KR, KZ, LA, LC, LK, LR, LS, LU, LY, MA, MD, ME, MG, MK, MN, MW, MX, MY, MZ, NA, NG, NI, NO, NZ, OM, PA, PE, PG, PH, PL, PT, QA, RO, RS, RU, RW, SA, SC, SD, SE, SG, SK, SL, SM, ST, SV, SY, TH, TJ, TM, TN, TR, TT, TZ, UA, UG, US, UZ, VC, VN, ZA, ZM, ZW.

- (84) **Bestimmungsstaaten** (soweit nicht anders angegeben, für jede verfügbare regionale Schutzrechtsart): ARIPO (BW, GH, GM, KE, LR, LS, MW, MZ, NA, RW, SD, SL, ST, SZ, TZ, UG, ZM, ZW), eurasisches (AM, AZ, BY, KG, KZ, RU, TJ, TM), europäisches (AL, AT, BE, BG, CH, CY, CZ, DE, DK, EE, ES, FI, FR, GB, GR, HR, HU, IE, IS, IT, LT, LU, LV, MC, MK, MT, NL, NO, PL, PT, RO, RS, SE, SI, SK, SM, TR), OAPI (BF, BJ, CF, CG, CI, CM, GA, GN, GQ, GW, KM, ML, MR, NE, SN, TD, TG).

Veröffentlicht:

- mit internationalem Recherchenbericht (Artikel 21 Absatz 3)

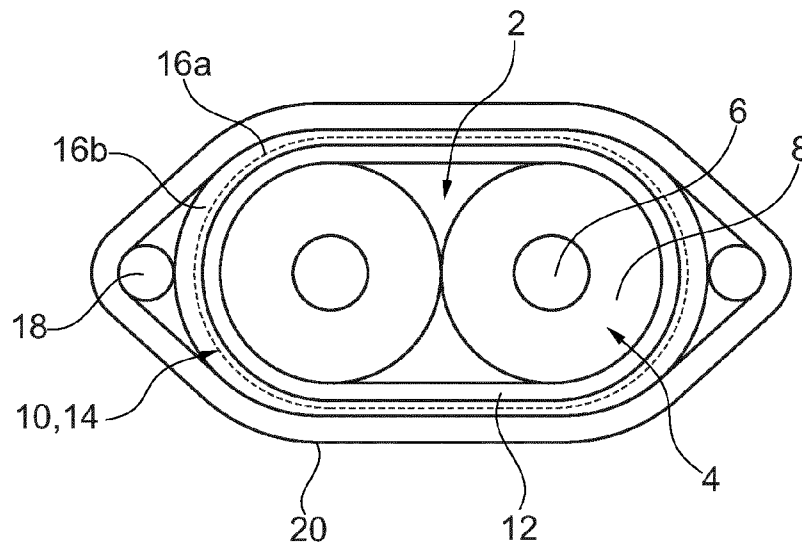
(54) **Title:** DATA CABLE FOR HIGH-SPEED DATA TRANSMISSIONS(54) **Bezeichnung:** DATENKABEL FÜR HIGH-SPEED DATENÜBERTRAGUNGEN**Fig. 1**

(57) **Abstract:** The data cable (22) for high-speed data transmissions comprises at least one conductor pair (2) that consists of conductors (4) extending in the longitudinal direction (17) and being surrounded by a shielding foil (14) to give a pair shielding unit (10), a dielectric intermediate foil (12), having a varying lay length (I), being spun around the conductor pair (2) between the shielding foil (14) and the conductor pair (2). In this way, a damping peak at high transmission frequencies is effectively avoided.

(57) **Zusammenfassung:**

[Fortsetzung auf der nächsten Seite]

WO 2016/012213 A1 

Das Datenkabel (22) für High-Speed-Datenübertragungen weist zumindest ein Adernpaar (2) aus zwei sich in Längsrichtung (17) erstreckenden Adern (4) auf, die zur Ausbildung einer Paarschirmung (10) von einer Schirmfolie (14) umgeben sind, wobei zwischen der Schirmfolie (14) und dem Adernpaar (2) eine dielektrische Zwischenfolie (12) als zusätzliche Folie um das Adernpaar (2) mit einer variierenden Schlaglänge (I) gesponnen ist. Hierdurch wird ein Dämpfungsspeak bei hohen Übertragungsfrequenzen wirksam vermieden.

Description

Data cable for high-speed data transmissions

5 The invention relates to a data cable for high-speed
data transmissions, with at least one pair of wires
consisting of two wires extending in the longitudinal
direction which for the purpose of forming a pair
shielding are surrounded pairwise by a shielding foil,
10 a non-conductive intermediate film having been spun
around the pair of wires as an additional film between
the shielding foil and the pair of wires. At the time
of filing, a data cable of such a type is being offered
for sale by the applicant under the brand name "23
15 Paralink". Data cables of such a type are employed, in
particular, for the high-speed transmission of signals
between computers, for example in computing centers.

In the field of data transmission, for example in
20 computer networks, data cables are employed in which,
typically, several data lines have been combined in a
common cable jacket. In the case of high-speed data
transmissions, in each instance shielded pairs of wires
are used as data lines, the two wires running, in
25 particular, parallel to one another or alternatively
having been twisted together. A respective wire in
this case consists of the actual conductor, for example
a solid conductor wire or even a stranded wire, which
in each instance is surrounded by an insulation. The
30 pair of wires of a respective data line is surrounded
by the (pair) shielding. The data cables typically
exhibit a plurality of pairs of wires shielded in such
a manner, which form a line core and which are
surrounded by a common outer shield and a common cable
35 jacket. Data cables of such a type are employed for
high-speed data connections and are designed for data
rates of more than 10 Gbit/s at a transmission
frequency greater than 14 GHz. The outer shield in
this case is important for the electromagnetic

- 2 -

compatibility (EMC) and also for the electromagnetic interference (EMI) with the environment. No signals are transmitted via the outer shield. The respective pair shield, in contrast, determines the symmetry and the signal properties of a respective pair of wires. In this connection, a high symmetry of the pair shield is important for an undisturbed transmission of data.

In the case of data cables of such a type it is typically a question of so-called symmetrical data lines, in which the signal is communicated via the one wire and the inverted signal is communicated via the other wire. The differential signal component between these two signals is evaluated, so that external effects that act on both signals have been eliminated.

Data cables of such a type are frequently linked to connectors in preassembled form. In the case of applications for high-speed transmissions, the connectors are frequently designed as so-called small-form-pluggable connectors, SFP connectors for short. In this case there are differing practical variants, for example so-called SFP+, CXP or QSFP connectors. These connectors exhibit special connector housings such as can be gathered from WO 2011/072869 A1 or from WO 2011/089003 A1, for example. Alternatively, a direct so-called back-plane connection without connector is also possible.

The pair shielding of a respective pair of wires in this case is frequently formed - as can be gathered from EP 2 112 669 A2, for example - as a longitudinally folded shielding foil. The shielding foil has therefore been folded around the pair of wires, running in a longitudinal direction of the cable, the opposite outer side regions of the shielding foil overlapping in an overlapping region running in the longitudinal direction. In order to guarantee a defined seating of

- 3 -

this longitudinally folded shielding foil, and to avoid a kinking of the same into a filler region between the two wires, a dielectric intermediate film consisting of plastic, in particular a PET film, has been spun
5 between the shielding foil and the pair of wires.

In the case of the shielding foil used for the shielding, it is a question of a multilayered shielding consisting of at least one conductive (metal) layer and
10 an insulating backing layer. By way of conductive layer, use is ordinarily made of a layer of aluminum, and by way of insulating layer, use is ordinarily made of a film of PET. The PET film takes the form of a support on which a metallic coating has been applied
15 for the purpose of forming the conductive layer.

In addition to the longitudinally folded shielding in the case of pairs guided in parallel, in principle there is also the possibility of wrapping or spinning a
20 shielding foil of such a type around the pair of wires in the form of a helix. However, at higher signal frequencies starting from approximately 15 GHz such a wrapping of the pair of wires with a shielding foil is not readily possible, by reason of resonance effects
25 due to the type of construction. For these high frequencies, the shielding foil is therefore frequently preferentially attached as a longitudinally folded shielding foil.

30 From DE 10 2012 204 554 A1 a signal cable for a high-frequency signal transmission can be gathered, in the case of which the signal conductor takes the form of a stranded conductor with a varying length of lay. In supplement, the signal cable further exhibits a
35 shielding braiding, individual braiding strands of the shielding braiding having been wound, here also, with a varying length of lay. By virtue of these measures, the transmission quality is improved.

- 4 -

From DE 103 15 609 A1 a data cable for a high-frequency transmission of data can be gathered, in which a pair of wires is surrounded by a pair shielding taking the
5 form of a shielding foil. In supplement, an intermediate film has also been spun around the pair of wires.

From US 2014/0124236 A1 a further high-speed data cable
10 can be gathered, in which a shielding foil provided in the form of a pair shielding has been spun around the pair of wires with a varying length of lay.

Proceeding from this, the object underlying the
15 invention is to specify a high-speed data cable with good transmission properties also at high transmission rates and high transmission frequencies.

In accordance with the invention, the object is
20 achieved by a data cable for high-speed data transmissions with at least one pair of wires consisting of two wires extending in the longitudinal direction, which, in particular, run parallel to one another and which for the purpose of forming a pair
25 shielding are surrounded pairwise by a shielding foil. Between the shielding foil and the pair of wires a dielectric intermediate film has been spun around the pair of wires as an additional film. The additional dielectric intermediate film in this case has been spun
30 around the pair of wires with a varying length of lay.

The data cable takes as its starting-point, in particular, a data cable with a longitudinally folded shielding foil with the additional intermediate film
35 between wire pair and the pair shielding. Studies have shown that at very high transmission frequencies a peak-type attenuation occurs also in data cables of such a type. This peak-type attenuation could be

- 5 -

distinctly reduced by variation of the length of lay of the dielectric intermediate film. It will be assumed that the peak-type attenuation is to be attributed to a reflection effect by reason of the periodic interference structure with the period of the length of lay, which has been introduced by the wrapping of the intermediate film. In each instance a part of the signal is reflected on this interference structure. By virtue of the strict periodicity, a narrowband, sharp attenuation at high frequencies is formed, due to the reflection effects at the plurality of points of interference. This results, therefore, in a high attenuation peak at high frequencies in the case of the so-called insertion loss. By "insertion loss" in the present case is understood the attenuation that a signal undergoes when passing through a signal path (cable length). By virtue of the periodic structure, in addition this also results in a high attenuation peak at high frequencies in the case of the so-called return loss. In this case, on the feed side of the signal a signal peak that correlates with the absorption peak of the insertion loss is obtained at the high frequency by reason of the reflections.

In principle, there would be the possibility to shift the attenuation frequency toward higher frequencies by geometrical measures such as, for example, a shorter length of lay. In the ParaLink cables described in the introduction, this is obtained by a very steep pitch of the winding. The length of lay in this case is, in particular, approximately 3 mm, so the peak-type insertion loss and hence also the return loss lies above 25 GHz. According to the currently applicable standards, a peak of such a type in such lines must not occur within the frequency range up to 25 GHz. However, by reason of the more intense wrapping, the short length of lay results in a low processing speed

- 6 -

in the course of the wrapping of the pair of wires, leading to higher costs.

Accordingly, in conventional data cables with the intermediate film a comparatively large attenuation (attenuation peak) occurs by reason of the addition of all the individual reflections at a fixed, narrow frequency. As a result, a high attenuation of the signal occurs, so the requirements of the so-called insertion loss for high transmission frequencies are only satisfied inadequately. In contrast, by reason of the varying length of lay no attenuation peak is present any longer at a fixed frequency, so the requirements of the insertion loss are satisfied also at high frequencies. At the same time, as a result there is the possibility to lengthen the length of lay and hence to increase the processing speed and consequently lower the costs.

By "length of lay" or "pitch" of the intermediate film in this connection, the spacing in the longitudinal direction of the cable is understood that the wrapping needs for a 360° revolution around the pair of wires.

In an expedient further development in this connection, the length of lay is varied within the range of at least +/-5 % and, in particular, of at least +/-10 %, relative to a mean length of lay. Just this comparatively small variation has proved sufficient to avoid the undesirable attenuation peak. An upper limit of the variation is, for example, +/-40 %.

The mean length of lay of the intermediate film in this case preferentially lies within the range of a few millimeters, in particular within the range from 5 mm to 15 mm. In particular, the mean length of lay in this case lies approximately between 6 mm and 8 mm. With this length of lay, a fast and reliable - in terms

- 7 -

of process engineering - production of the wrapping of the intermediate film is made possible. A high processing speed is achieved. At the same time, the properties desired with the intermediate film can be
5 obtained by this means - namely a defined, fixed wrapping of the pair of wires, in order to place the shielding foil attached over it in a defined uniform geometry around the pair of wires, so that no symmetrical points of interference of the shielding
10 foil have been formed.

The particular advantage of the varying length of lay becomes clear on the basis of the following example: in the case of a length of lay of 6 mm, about 166
15 wrappings, and hence 166 periodic points of interference, result per meter. As a consequence of these points of interference at 15 GHz, this results in a sharp peak in the return loss, which at the base is only approximately 180 MHz wide. In the case of a
20 variation by +/-15 %, the base is widened to 4500 MHz and the maximum is distinctly reduced.

In this case the length of lay expediently varies uniformly and in particular continuously, for example
25 sinusoidally, in the longitudinal direction. The length of lay therefore varies between a maximum value and a minimum value around the mean value. In terms of process engineering this can be achieved, for example, by a variation of the draw-off speed of the pair of
30 wires in the course of the wrapping process and/or by a variation of the spinning speed. Expediently, in this case the length of lay in the longitudinal direction varies periodically with a period length that preferentially lies within the range of a few meters,
35 in particular within the range from 1 m to 5 m, and preferably amounts to 2 m. By "period length of the variation", the length in the longitudinal direction is therefore understood, which lies between two maximum

- 8 -

values of the length of lay. By virtue of this periodicity, although a periodic point of interference is introduced in turn, by reason of the chosen period length for the transmission frequencies of interest in the present case, and with the typical cable lengths, this is irrelevant.

A further, in particular adhesive, outer film has expediently been spun around the pair shielding. Said outer film serves, in particular, for fixing the entire structure. Said outer film is, in turn, a dielectric film, in particular a PET film.

In a preferred further development, there is provision that this outer film also exhibits a varying length of lay. The arguments and preferred embodiments adduced with regard to the intermediate film are also to be applied in like manner to this outer film. Said outer film therefore preferentially exhibits identical or at least comparable lengths of lay and an identical or at least similar variation of the length of lay as the intermediate film. Said outer film has expediently been spun in the opposite direction with respect to the intermediate film.

Furthermore, the intermediate film has preferentially been spun around the pair of wires with a mean length of lay that is different to a length of lay of the shielding foil. In principle, the differing attenuation effects that arise by reason of differing physical boundary conditions, on the one hand of the shielding foil and on the other hand of the intermediate film, can, as a result, each be selectively reduced or avoided.

In particular, there is provision that the shielding foil has been spun around the pair of wires with constant length of lay.

- 9 -

In an expedient configuration the shielding foil is a longitudinally folded foil - that is to say, virtually a shielding foil in which the length of lay is infinite. By virtue of this measure, the attenuation effect of the shielding foil by reason of the previously described resonance effect has been reliably avoided.

10 The shielding foil exhibits, in principle, a multilayered structure with an insulating backing layer, also designated as a backing film, and with a conductive layer attached thereto. The backing layer is, in particular, a dielectric plastic film, in particular a PET film. In the case of the conductive layer attached thereto, it is a question, in particular, of a layer of aluminum which, for example, has been applied onto the backing film by vapor deposition.

20 Ordinarily, the entire data cable further exhibits a cable jacket which has been arranged around the at least one pair of wires. The data cable typically exhibits several pairs of wires provided with a pair shielding, the pairs of wires ordinarily running, stranded together, within the common cable jacket. In supplement, an outer shielding has typically been arranged around the entire composite of the individual pairs of wires. In this case it is a question, for example, of a shielding braiding and/or a multilayered shielding structure. This outer shielding has been galvanically separated with respect to the individual pair shields. This is obtained, in particular, via the aforementioned outer film of each pair, or even by a common insulating film which surrounds the stranded composite of the pairs of wires.

According to an aspect of the present invention there is provided a data cable for high-speed data transmissions, the data cable comprising:

at least one wire pair, each wire pair being formed
5 of two wires extending in a longitudinal direction;

at least one shielding foil, each shielding foil surrounding a respective wire pair to form a pair shielding; and

at least one dielectric intermediate film, each
10 dielectric intermediate film being spun around a respective wire pair as an additional film between said shielding foil and said wire pair, said dielectric intermediate film being spun around said wire pair with a varying length of lay.

- 10 -

Embodiments of the invention will be elucidated in more detail below with reference to the figures. The latter show, in each instance in simplified representations:

- 5 Fig. 1 a cross-sectional representation of a pair of wires, surrounded by a pair shielding, of a data cable,
Fig. 2 in a detailed side view, the pair of wires, wrapped with an intermediate film, according
10 to fig. 1,
Fig. 3 a schematic cross-sectional representation of a data cable with two shielded pairs of wires,
Fig. 4 an illustration of the variation of the
15 length of lay of the intermediate film,
Fig. 5A a representation of the insertion loss in the case of a conventionally shielded pair of wires, and
Fig. 5B a representation of the insertion loss in the
20 case of a pair of wires that has been provided with an intermediate film wound with varying length of lay,
Fig. 6A a representation, correlated with fig. 5A, of the return loss in the case of the
25 conventionally shielded pair of wires, and
Fig. 6B a representation, correlated with fig. 5B, of the return loss in the case of the pair of wires that has been provided with an
intermediate film wound with varying length
30 of lay.

In the figures, identically-acting parts have been provided with the same reference symbols.

- 35 In figs. 1 to 3 at least one wire pair 2, consisting of two wires 4, is represented, each wire 4 in turn exhibiting a central conductor 6 which is surrounded by a wire insulation 8. The wire pair 2 is surrounded in

- 11 -

each instance by a pair shielding 10 which surrounds the wire pair 2, with interpolation of an intermediate film 12.

5 In the embodiment variant according to fig. 1, the pair shielding 10 has been formed by a single multilayered shielding foil 14 which is formed a backing layer 16a taking the form of a PET backing film and also an aluminum coating, attached thereto, by way of
10 conductive layer 16b. The conductive layer 16b is oriented outward. In the case of shielding foil 14, it is a question of a longitudinally folded shielding foil 14, the longitudinal edges of which therefore run parallel to the wires 4 in the longitudinal direction
15 17. The wires 4 run in the longitudinal direction 17, untwisted and parallel to one another.

Furthermore, the entire pair structure has been wrapped by an adhesive outer film 20, with the aid of which the
20 entire structure is fixed. This outer film 20 is, in turn, a plastic film.

Between the pair shielding 10 and the outer film 20, drain wires 18 have furthermore been arranged which are
25 in electrical contact with the conductive layer 16b. The drain wires 18 serve for simplified connection of the pair shielding 10 in a connector region. The drain wires 18 lie on a common line of centers which also passes through the center axes of the wires 4. They
30 are situated, in particular, outside the intermediate film 12 and hence also outside filler regions between the wires 4. By virtue of the bilateral opposing arrangement, a highly symmetrical structure has been obtained. In principle, alternative configurations
35 with no drain wire or with only one drain wire are possible.

- 12 -

All the foils/films exhibit a thickness ordinarily within the range of merely a few μm . Insofar as it is a question of spun films - as is the case, in particular, with the intermediate film 12 and also the
5 outer film 20 - these typically exhibit a width within the range from 4 mm to 6 mm.

Whereas in the case of shielding foil 14 it is preferentially a question of a longitudinally folded
10 foil, the intermediate film 12 has been wound around the wire pair 2. This can be gathered, in particular, from the side view according to fig. 2. The intermediate film 12 has been wound around the wire pair 2 in this case with a mean length of lay l_m . The
15 length of lay 1 and hence the pitch of the intermediate film 12 varies in this case by a difference Δ around the mean length of lay 1.

In fig. 2 the representation of the pair shielding 10
20 has been dispensed with for a better overall view, and merely the intermediate film 12 can still be discerned.

A data cable 22, as represented in exemplary manner in fig. 3, typically exhibits one or more wire pairs 2,
25 each provided with a pair shielding 10. Each pair element preferably exhibits a structure such as has been described with reference to figs. 1 and 2. The individual wire pairs 2 surrounded by the pair shielding 10 form a transmission core which
30 subsequently is also surrounded by an outer shielding 24 which is galvanically separated from the pair shielding 10. In the case of the outer shielding 24 it is a question, in the embodiment, of a multilayered structure with, here, an exterior braiding shield 24A
35 and with an interior overall shielding foil 24B which has preferably been formed like shielding foil 14. The outer shielding 24 may also have been formed in one layer. Between the outer shielding and the

- 13 -

transmission core in the embodiment a further insulating film 25 has been spun. Around the outer shielding 24, finally, a cable jacket 26 has been arranged by way of outer protective sheath of the data cable 22. In this case it is typically a question of an extruded cable jacket 26.

In fig. 4 an exemplary curve of the variation of the mean length of lay 1 of the intermediate film 12 is represented. As can be discerned, the length of lay 1 varies around the mean length of lay l_m by the difference Δ between a maximum length of lay l_{max} and a minimum length of lay l_{min} . In this case the variation occurs uniformly and periodically and, in particular, in accordance with a sine curve represented in exemplary manner in fig. 4. This curve therefore exhibits a periodicity with a period length p which typically lies within the range of a few meters.

In the following, the effect of the variation of the length of lay 1 in the case of the intermediate film 12 will be elucidated with reference to figs. 5A and 5B and also 6A and 6B. The diagrams represented show, schematically in each instance, measurement curves in which the attenuation a in decibels dB has been plotted over the frequency f in gigahertz GHz. The measurement curves were implemented in the case of data cables 22 having a fundamental structure according to fig. 1 for the pair-shielded wire pair 2. In the case of the measurement according to figs. 5A, 6A, the basis was a conventional structure with an intermediate film 12 having constant length of lay 1, and in the case of the measurement curves of figs. 5B, 6B the basis was a structure having varying length of lay 1 of the intermediate film 12. The measurements were made with a mean length of lay l_m of the intermediate film 12 of approximately 6 mm. The length of lay 1 therefore lies distinctly above the conventionally chosen length of

- 14 -

lay of, typically, approximately 3 mm, which is required - if no varying length of lay has been set - in order to shift the attenuation peak toward sufficiently high frequencies above 25 GHz.

5

The pair of diagrams of figs. 5A, 5B shows the curve of the insertion loss [in dB] in a comparison of the two cable variants, and the diagram pair of figs. 6A, 6B shows the curve of the return loss [in dB] in a comparison of the two cable variants, in each instance plotted against the frequency.

10

As can be readily discerned, the insertion loss generally increases continuously with increasing frequency. At approximately 19 GHz the data cable 22 in the variant with the constant length of lay displays a very strong attenuation peak which, in the example shown here, displays an excursion of over 50 dB. Correspondingly, the return loss displays a similar curve and a reflection peak likewise at approximately 19 GHz. The height of the peak depends on the absolute attenuation and on the length of the line.

15

20

In contrast, in the case of the data cable 22 with the intermediate film 12 having the varying length of lay 1 neither a peak in the insertion loss nor a peak in the return loss exists within the corresponding frequency range. By virtue of the varying length of lay, the base of the peak is accordingly distinctly widened to a width of, preferentially, several GHz, in particular from 3 GHz to 6 GHz, for example. Correspondingly, the height of the peak is also distinctly reduced, and merely a wavy curve in the manner of a noise is evident over the width. The signal level of this noise amounts to only a fraction of the original peak height, for example less than 10 % of the original peak height.

30

35

List of Reference Symbols

	2	wire pair
	4	wire
5	6	conductor
	8	insulation of wire
	10	pair shielding
	12	intermediate film
	14	shielding foil
10	16a	backing layer
	16b	conductive layer
	17	longitudinal direction
	18	drain wire
	20	outer film
15	22	data cable
	24	outer shielding
	24A	braiding shield
	24B	shielding foil
	25	film
20	26	cable jacket
	a	attenuation
	f	frequency
	l	length of lay
25	l_m	mean length of lay
	l_{max}	maximum length of lay
	l_{min}	minimum length of lay
	p	period length
	Δ	difference of pitch
30	B	width

The embodiments of the invention in which an exclusive property or privilege is claimed are defined as follows:

1. A data cable for high-speed data transmissions, the data cable comprising:

at least one wire pair, each wire pair being formed of two wires extending in a longitudinal direction;

at least one shielding foil, each shielding foil surrounding a respective wire pair to form a pair shielding; and

at least one dielectric intermediate film, each dielectric intermediate film being spun around a respective wire pair as an additional film between said shielding foil and said wire pair, said dielectric intermediate film being spun around said wire pair with a varying length of lay.

2. The data cable according to claim 1, wherein said length of lay varies at least within a range of $\pm 5\%$ relative to a mean length of lay.

3. The data cable according to claim 1, wherein said length of lay varies at least within a range of at least up to $\pm 10\%$ relative to a mean length of lay.

4. The data cable according to claim 1, wherein said intermediate film has a mean length of lay lying within a range of from 5 mm to 15 mm.

5. The data cable according to claim 1, wherein said intermediate film has a mean length of lay amounting to 6 mm to 8 mm.

6. The data cable according to claim 1, wherein said length of lay varies uniformly in said longitudinal direction.

7. The data cable according to claim 1, wherein said length of lay varies periodically in said longitudinal direction with a period length lying within a range of from 1 m to 5 m.

8. The data cable according to claim 1, wherein said length of lay varies periodically in said longitudinal direction with a period length of 2 m.

9. The data cable according to any one of claims 1 to 8, which further comprises a further outer film spun around said pair shielding.

10. The data cable according to claim 9, wherein said further outer film has a varying length of lay.

11. The data cable according to claim 9 or 10, wherein said further outer film is an adhesive.

12. The data cable according to claim 1, wherein said at least one dielectric intermediate film is spun around said at least one wire pair with a length of lay being different than a length of lay of said at least one shielding foil.

13. The data cable according to any one of claims 1 to 12, wherein said at least one shielding foil and said at least one dielectric intermediate film are spun around said at least one wire pair with opposite-sense lays.

14. The data cable according to claim 1, wherein said at least one shielding foil is spun around said at least one wire pair with a constant length of lay.

15. The data cable according to any one of claims 1 to 14, wherein said at least one shielding foil is at least one longitudinally folded foil.

16. The data cable according to any one of claims 1 to 15, wherein said at least one shielding foil has a multilayered structure with an insulating backing layer and a conductive layer attached to said insulating backing layer.

17. The data cable according to any one of claims 1 to 16, wherein a course of a feed of a high-frequency data signal within a GHz range, at least within a frequency band up to 25 GHz, causes no signal peak to occur either in an insertion loss or in a return loss.

1/4

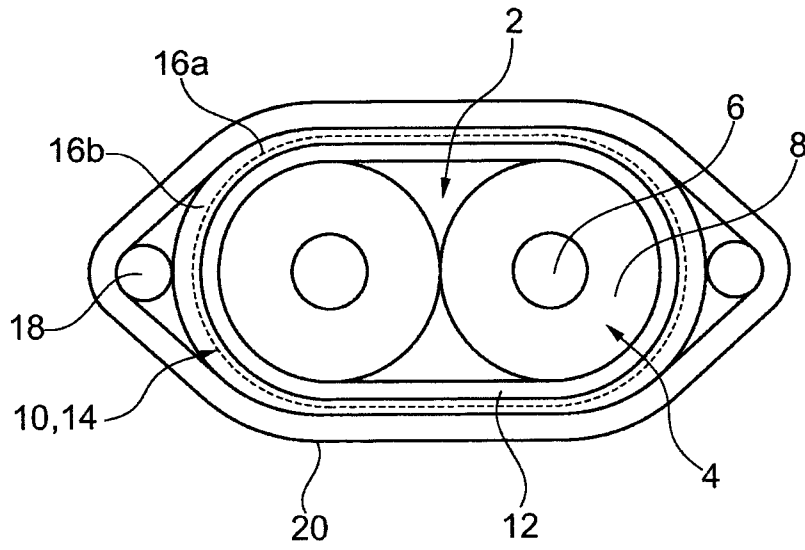

Fig. 1

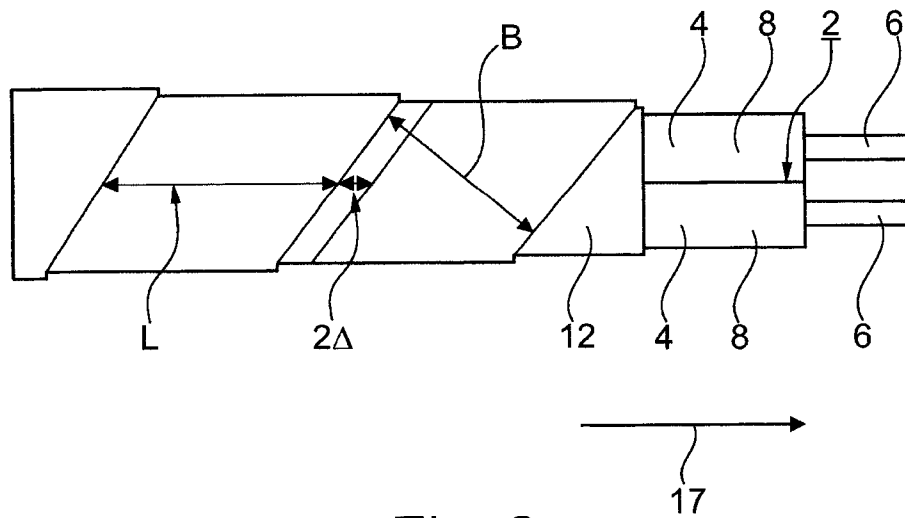

Fig. 2

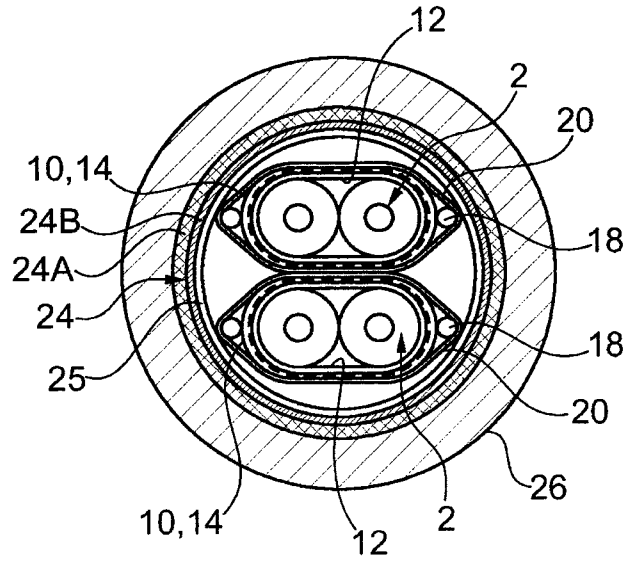

Fig. 3

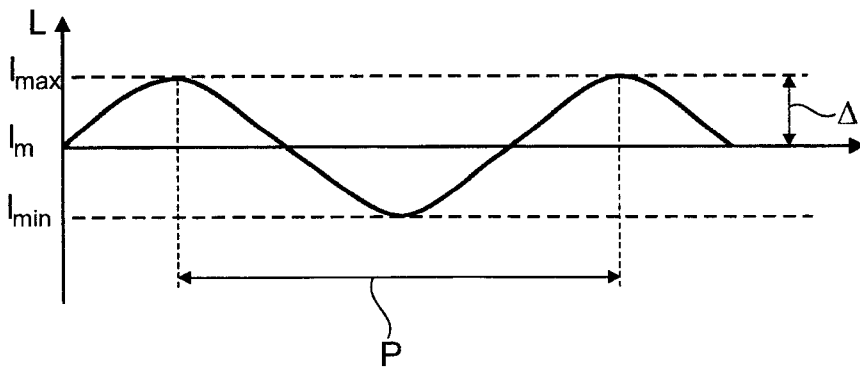

Fig. 4

3/4

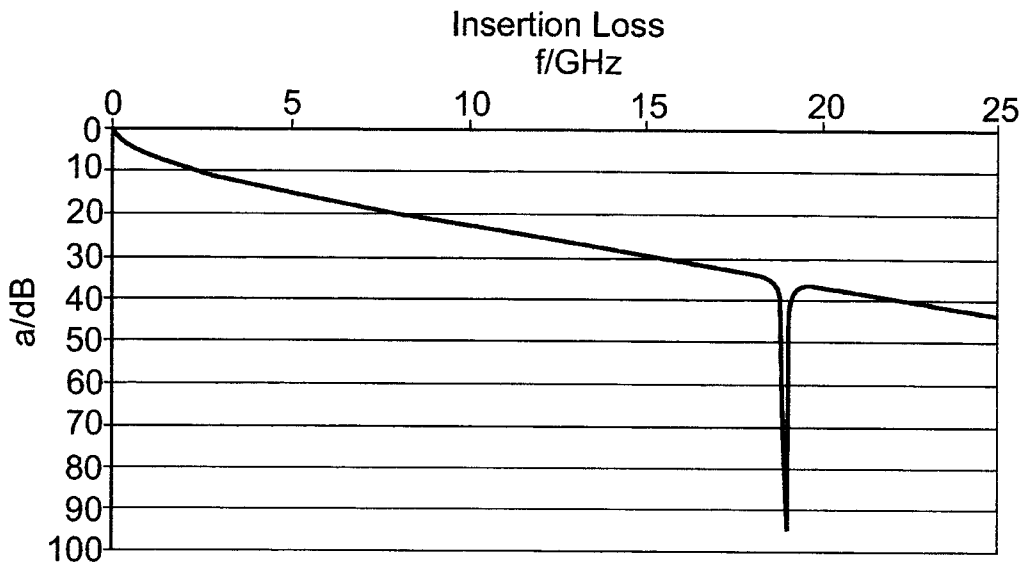

Fig. 5A

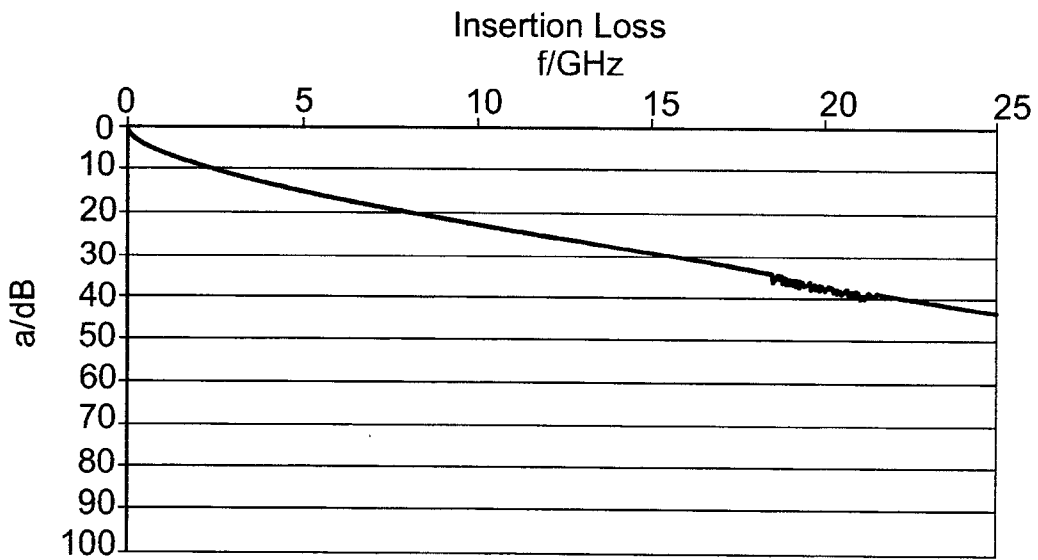

Fig. 5B

4/4

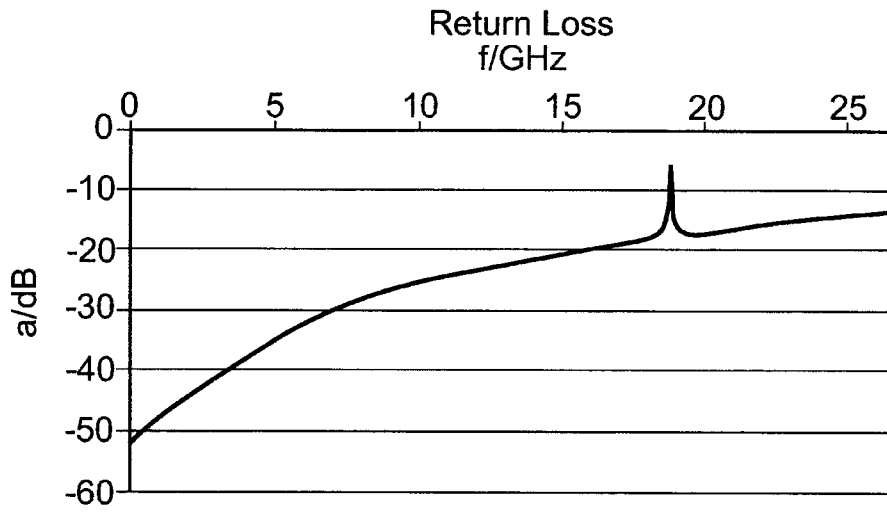

Fig. 6A

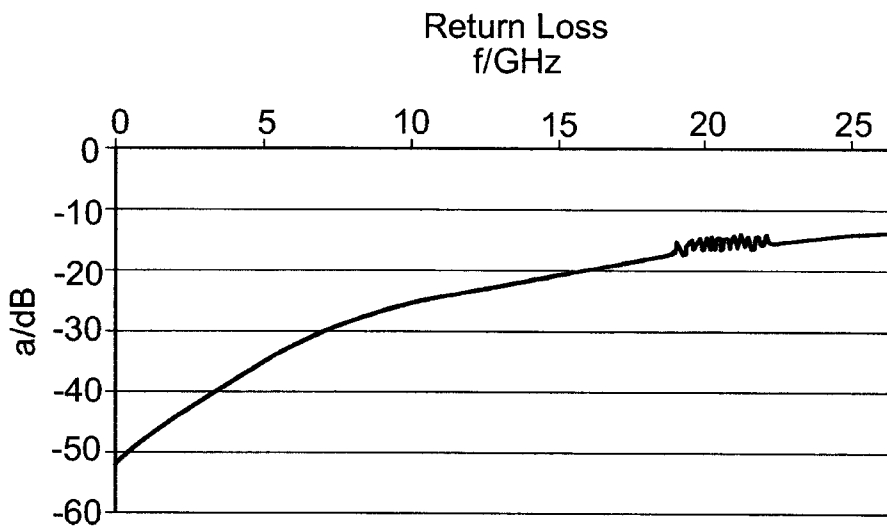

Fig. 6B

