

U. Blickensderfer,

Excavator.

No. 106653.

Patented Aug. 23. 1870.

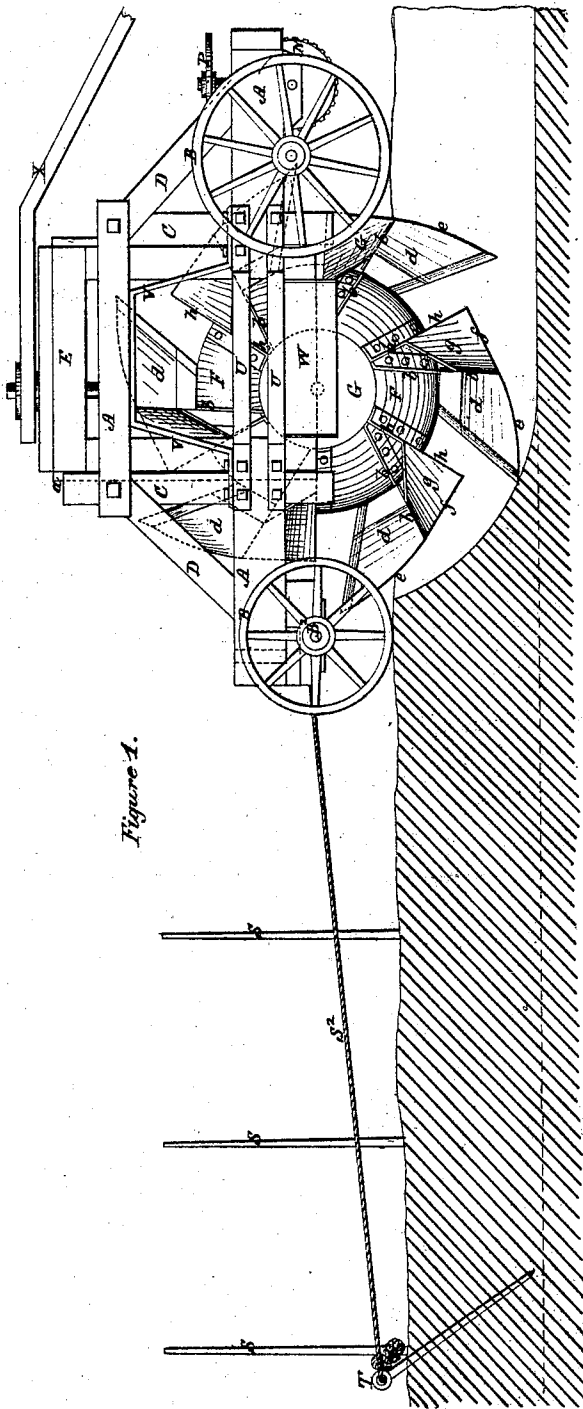

Figure 1.

Witnesses
 G. H. Hamilton Johnson
 Chas. Collyerman

Inventor
 Ulic Blickensderfer
 By his attorneys,
 W. H. H. Johnson

U. Blickensderfer, 2. Sheets, Sheet 2.

Excavator.

No. 106,653.

Patented Aug. 23, 1870.

Figure 6.

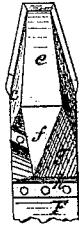

Figure 5.

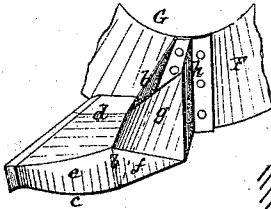

Figure 2.

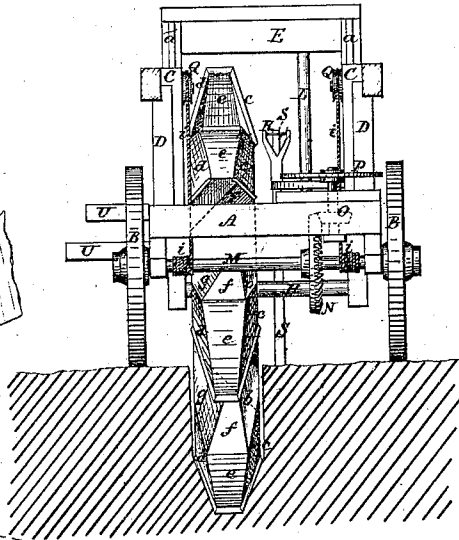

Figure 4.

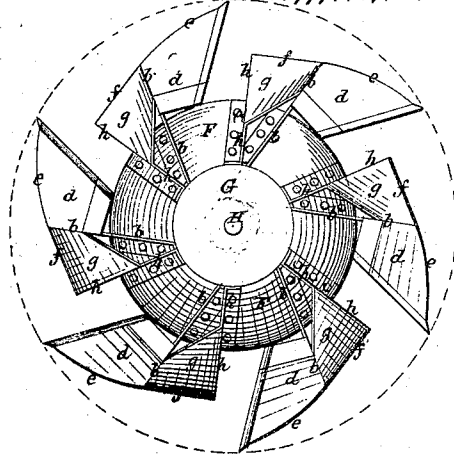
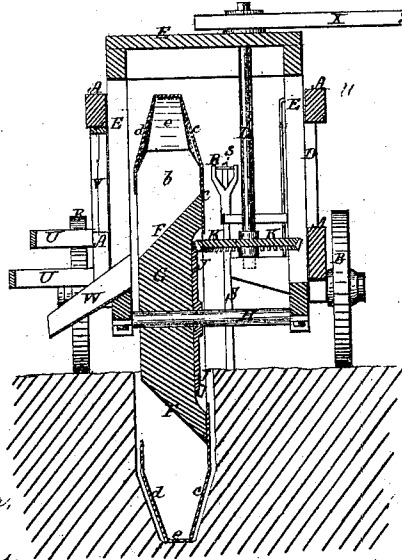

Figure 3.



Witnesses.
A. W. Hamilton, Arthur
Chas. Clipperman
Inventor.
U. Blickensderfer,
By his attorneys,
Clipperman & Johnson

UNITED STATES PATENT OFFICE.

ULRIC BLICKENSDEKFER, OF SPRINGFIELD, PENNSYLVANIA.

IMPROVEMENT IN DITCHING-MACHINES.

Specification forming part of Letters Patent No. 106,653, dated August 23, 1870.

To all whom it may concern:

Be it known that I, ULRIC BLICKENSDEKFER, of Springfield, in the county of Erie and State of Pennsylvania, have invented certain new and useful Improvements in Ditching-Machines; and I do hereby declare that the following is a full, clear, and exact description thereof, reference being had to the accompanying drawings, which make part of the same, and in which—

Figure 1 represents an elevation of a machine embracing my improvements, it being shown in the position it occupies when in operation. Fig. 2 represents an elevation of the rear end of the machine. Fig. 3 represents a transverse section of the same. Fig. 4 represents an elevation of the discharging side of the buckets and their hub; Fig. 5, a view in perspective of one of the buckets, and Fig. 6 an elevation of the back of the same.

My improvements relate to machines for ditching and draining lands, and the accompanying drawings represent such a machine as consisting of an oblong frame, A, mounted upon supporting-wheels B in any suitable manner. Four grooved standards, C, connected by rails above the main frame and braced by diagonal bars D, are secured to this frame near the middle of its length, so as to project above and below the same, between which is secured a vertical adjustable frame, E, which carries the revolving ditching-buckets. This adjustable frame is provided with tongues *a*, which fit into the grooves of the vertical standards C, so as to guide it while being raised, and allow it to descend by its own weight.

The ditching-buckets are secured directly upon and to the oblique surface F of a solid or hollow hub, G, equal in thickness to the width of the buckets, made in the form of a frustum of a cone, and mounted on a horizontal shaft, H, secured in suitable bearings. They are of peculiar construction, consisting of a back plate, *b*, secured to the inclined face of the hub, so as to form a tangent to a circle of a diameter less than that of the smallest end of the hub, having for its center the axis of the hub, having one of their sides, *c*, secured to one side of the hub G, while their other sides, *d*, are left open for the discharge of the soil, and are therefore on the side of the inclined or discharging surface F of the

hub, as shown in Figs. 3, 4, and 5. Their outer sides are coincident with circles struck from points eccentric with the axis, so that the outer side, *e*, of the bucket recedes from its cutting-point for two purposes—to clear the soil entirely after it has made its cut, and to increase the area of the bucket gradually from its cutting-edge to its back, which is produced by converging the opposite sides, *c* and *d*, of the bucket toward *e*, and curving and converging the latter toward its cutting-edge from the back *b*, as shown in Figs. 2, 3, 5, and 6 of the drawings. The sides of the buckets, thus inclined and curved, enlarge the space within them, and allows the soil to spread, and, instead of packing itself within the bucket, is entirely loose and free to be discharged therefrom as each bucket approaches a vertical position. The front edges of these buckets may be made of boiler-iron, and the cutting-edges laid with steel. They are braced and secured to the hub by means of angular braces, a part, *f*, of which forms a continuation of the outer side, *e*, of the bucket, while another side, *g*, has its base-line parallel, or thereabout, with the inclined face F of the hub, and these two angles meet and are connected to the hub G by a radial portion, *h*, directly in front of each bucket, in such manner as not to interfere with the mouth or cutting-edges thereof, while they form chutes in front of each bucket to direct the earth therefrom, and prevent it from falling out upon the back of the adjacent bucket and scattering. The buckets thus constructed are arranged suitable distances apart, and motion is communicated to them by a bevel-gear wheel, J, secured to the inner face of the hub, which meshes into a horizontal bevel-gear wheel, K, secured upon the lower end of a driving-shaft, L, mounted in suitable bearings in the vertical adjustable frame E, to the upper projecting end of which one or more levers, X, are secured, to which the horses are attached, so that the latter, traveling around the machine in a circle, impart motion to the revolving buckets.

The mechanism for raising and lowering the frame which carries the buckets consists of a shaft, M, secured transversely in bearings at the rear end of the main frame, carrying at one end a bevel-gear wheel, N, into which meshes a smaller bevel-gear wheel, O, on the

vertical shaft of a hand-wheel, P. To the transverse shaft M are secured the ends of two ropes or chains, *i*, arranged at each side of the main frame, and their opposite ends pass up over sheaves Q, secured to the standards C, and are connected to the lower side of the vertical adjustable frame E, so that as the attendant turns the wheel P these cords may be wound or unwound upon or from the shaft M, and thus raise or lower the frame which carries the buckets, to cut the ditch a greater or less depth. In order to cut the bottom of the ditch horizontal, or with a regular descending grade, without regard to the surface of the ground, I employ a graduating-sight, R, Figs. 2 and 3, secured to the vertical adjustable frame E, which, in connection with a series of graded stakes, S, driven into the ground in advance of the machine at suitable distances apart, produces the result just stated. The sight R is secured to the frame E, so that it may be adjusted higher or lower, and set when the buckets have reached the required depth of ditch, and when the sight is once obtained with the graded stakes, the attendant, who stands at the wheel P, can easily control the latter, so as to maintain the depth or grade of cut thus established. This is important, especially in land of irregular surface, as it obviates the necessity of subsequently grading the ditch.

The machine is drawn along by means of a rope or chain, S², the front end of which is attached to a strong stake or anchor, T, driven into the ground some distance in advance of the machine, the other end of said rope being passed around the axles B² H, and thence to the rear of the machine, where it is held by the attendant, so as to take up the slack. Whenever the buckets come in contact with a stone or other obstruction, so as to prevent their proper operation, the attendant need only slack the drawing-chain, when the machine will back up, so that the obstruction may be removed. The discharging side of the carriage-frame is left open, and braced and supported by two horizontal iron yokes, U, and a vertical iron yoke, V, so as to leave an unobstructed opening at the discharging side, and for the movement of a chute or spout, W, secured to the vertical frame in a position near the inclined face F of the hub, so as to rise and fall with the latter

and discharge the earth at the side of the machine, and the supporting-wheels may extend out from the side of the frame a suitable distance to allow the deposit of the earth free from them.

The buckets being mounted upon a hub of equal thickness with their width, and braced and secured directly upon its inclined face, adds increased strength to them, admits of a smaller wheel being used; and allows the hub to descend into the ditch nearly on a line with its supporting-shaft.

The horse or horses may cross the ditch in the rear of the machine over a bridge attached to and drawn after it.

Having described my invention, I claim—

1. The ditching-buckets arranged and secured directly upon the surface of a frustum-of-a-cone hub, G, having a thickness equal to the width of the buckets, as herein shown and described.

2. The buckets having a gradually-increasing area from their cutting-edges to their backs *b*, for the purpose of facilitating the discharge of the earth therefrom and relieving their outer sides, *e*, from friction, as described.

3. The ditching-buckets arranged as described, provided with angular braces *f g h*, in such manner that each brace shall also form part of a chute to the discharging-mouth of each succeeding bucket, substantially as described.

4. In combination with a ditching-machine, an adjustable sight, R, and graduated stakes S, for the purpose of graduating and maintaining a uniform depth of cut or given grade in the ditch, substantially in the manner herein described.

5. The arrangement, in a ditching-machine, of a frustum-of-a-cone hub, G, having buckets shaped and braced as described, the vertical supporting and carrying frame E, the hand-wheel P, the yoke-braces U V, and the sight R and graduated stakes S, the whole constructed, arranged, and operating as described.

In testimony whereof I have hereunto signed my name.

ULRIC BLICKENSDECKER.

Witnesses:

I. NEWTON MILLER,
F. D. MILLER.