

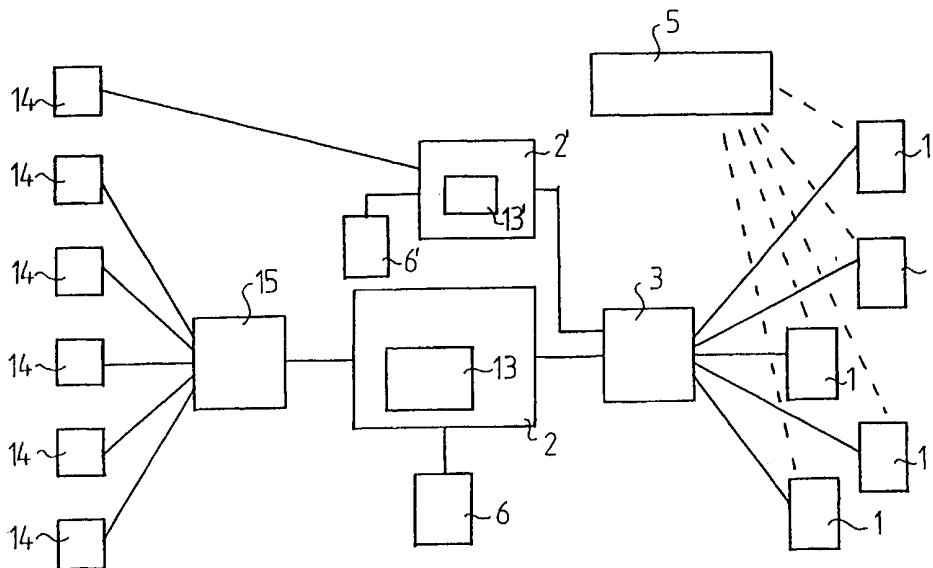

INTERNATIONAL APPLICATION PUBLISHED UNDER THE PATENT COOPERATION TREATY (PCT)

<p>(51) International Patent Classification ⁶ : G09B 29/10</p>	<p>A1</p>	<p>(11) International Publication Number: WO 99/67765 (43) International Publication Date: 29 December 1999 (29.12.99)</p>
<p>(21) International Application Number: PCT/SE99/01081 (22) International Filing Date: 16 June 1999 (16.06.99) (30) Priority Data: 9802174-4 17 June 1998 (17.06.98) SE 9803176-8 18 September 1998 (18.09.98) SE (71)(72) Applicant and Inventor: ISMAIL, Ziad [SE/SE]; Froskarbacken 1, 1gh 107, S-104 05 Stockholm (SE). (74) Agents: BERGLUND, Stefan et al.; Bjerkéns Patentbyrå KB, Östermalmsgatan 58, S-114 50 Stockholm (SE).</p>		<p>(81) Designated States: AL, AM, AT, AT (Utility model), AU, AZ, BA, BB, BG, BR, BY, CA, CH, CN, CU, CZ, CZ (Utility model), DE, DE (Utility model), DK, DK (Utility model), EE, EE (Utility model), ES, FI, FI (Utility model), GB, GE, GH, GM, HR, HU, ID, IL, IS, JP, KE, KG, KP, KR, KZ, LC, LK, LR, LS, LT, LU, LV, MD, MG, MK, MN, MW, MX, NO, NZ, PL, PT, RO, RU, SD, SE, SG, SI, SK, SK (Utility model), SL, TJ, TM, TR, TT, UA, UG, US, UZ, VN, YU, ZW, ARIPO patent (GH, GM, KE, LS, MW, SD, SL, SZ, UG, ZW), Eurasian patent (AM, AZ, BY, KG, KZ, MD, RU, TJ, TM), European patent (AT, BE, CH, CY, DE, DK, ES, FI, FR, GB, GR, IE, IT, LU, MC, NL, PT, SE), OAPI patent (BF, BJ, CF, CG, CI, CM, GA, GN, GW, ML, MR, NE, SN, TD, TG).</p> <p>Published <i>With international search report. Before the expiration of the time limit for amending the claims and to be republished in the event of the receipt of amendments. In English translation (filed in Swedish).</i></p>

(54) Title: A DEVICE AND A METHOD FOR PROVIDING A SERVICE



(57) Abstract

The invention refers to a device and a method for providing at least one service to at least one of a number of users who are connected to the device. The device includes a portable unit (1) for each user and at least one central unit (2, 2') having a computer (13, 13'). Furthermore, the device includes first means (15), which are arranged to enable communication from at least one producer (14) of said service to said central unit, second means (5) which are arranged to determine the geographic position of essentially each portable unit (1), and third means (3) which are arranged to enable communication in both directions between each portable unit and said central unit via a wireless communication network. The central unit (2, 2') is arranged to provide said service to the portable units fulfilling a certain criterion with respect to said geographic position.

FOR THE PURPOSES OF INFORMATION ONLY

Codes used to identify States party to the PCT on the front pages of pamphlets publishing international applications under the PCT.

AL	Albania	ES	Spain	LS	Lesotho	SI	Slovenia
AM	Armenia	FI	Finland	LT	Lithuania	SK	Slovakia
AT	Austria	FR	France	LU	Luxembourg	SN	Senegal
AU	Australia	GA	Gabon	LV	Latvia	SZ	Swaziland
AZ	Azerbaijan	GB	United Kingdom	MC	Monaco	TD	Chad
BA	Bosnia and Herzegovina	GE	Georgia	MD	Republic of Moldova	TG	Togo
BB	Barbados	GH	Ghana	MG	Madagascar	TJ	Tajikistan
BE	Belgium	GN	Guinea	MK	The former Yugoslav Republic of Macedonia	TM	Turkmenistan
BF	Burkina Faso	GR	Greece	ML	Mali	TR	Turkey
BG	Bulgaria	HU	Hungary	MN	Mongolia	TT	Trinidad and Tobago
BJ	Benin	IE	Ireland	MR	Mauritania	UA	Ukraine
BR	Brazil	IL	Israel	MW	Malawi	UG	Uganda
BY	Belarus	IS	Iceland	MX	Mexico	US	United States of America
CA	Canada	IT	Italy	NE	Niger	UZ	Uzbekistan
CF	Central African Republic	JP	Japan	NL	Netherlands	VN	Viet Nam
CG	Congo	KE	Kenya	NO	Norway	YU	Yugoslavia
CH	Switzerland	KG	Kyrgyzstan	NZ	New Zealand	ZW	Zimbabwe
CI	Côte d'Ivoire	KP	Democratic People's Republic of Korea	PL	Poland		
CM	Cameroon	KR	Republic of Korea	PT	Portugal		
CN	China	KZ	Kazakstan	RO	Romania		
CU	Cuba	LC	Saint Lucia	RU	Russian Federation		
CZ	Czech Republic	LI	Liechtenstein	SD	Sudan		
DE	Germany	LK	Sri Lanka	SE	Sweden		
DK	Denmark	LR	Liberia	SG	Singapore		
EE	Estonia						

5 A device and a method for providing a service

THE BACKGROUND OF THE INVENTION AND PRIOR ART

10 The present invention refers to a device for providing at least one service to a number of users which are connected to the device. Furthermore, the invention refers to a method for providing at least one service to a number of users by means of at least one central unit, which comprises a computer.

15 Many places, for instance cities, are frequently visited by persons who do not have any or only a small knowledge of the local geography regarding the place in question. Such persons may for instance be tourists or businessmen visiting many different foreign places. These persons are confronted with many different problems
20 regarding orientating themselves geographically and finding the address to be visited. Furthermore, it may be difficult to such persons to know about and find for instance interesting museums, theatres, exhibitions and other types of events. It is also difficult for a person, who is located at a place where he maybe has not been
25 previously, to find restaurants which suit the taste of the person in question. Consequently, persons visiting foreign places normally need information related to the foreign place.

30 Producers of different services and products within an area also have a desire to reach, in a simple and comfortable manner, persons visiting the area in order to inform about their offer of services and products.

35 These information needs are satisfied today by means of maps and different prospects, which may be distributed at tourist information bureaux, in shops, at hotels etc and by means of newspapers and different types of advertisement products. However, it is both time-

consuming and difficult to find and evaluate all such printed matters in order to extract the information which is essential for a certain individual and in a certain situation.

- 5 JP-A-08292714 discloses a tourist guide device arranged to receive a GPS signal and disclose information about an area regarding maps, destinations, present places etc. The information is read from an external medium and stored in the device.
- 10 GB-A-2 278 196 discloses a unit which is arranged to disclose information related to the geographic position of the unit. The unit includes a receiver which is arranged to receive a position signal via the GPS system and a computer arranged to load the information, which is adequate for a certain position, from a
15 database and thereafter disclose the information to a user. The database may be stored on a local medium of the unit or stored centrally and may be obtained via for instance radio transmission. However, the known unit does not seem to be arranged to communicate with any central unit.
- 20 WO-A-93/20546 discloses a similar unit which is arranged to load tourist information from a local storing medium of the unit and from a central medium via radio transmissions. Furthermore, the unit is arranged to receive a position signal and by means of this position,
25 adequate information is processed and disclosed.

However, these known devices all have the disadvantage that they do not enable a producer of a service or a product to reach a certain selection of users, for instance one or several users.

30

SUMMARY OF THE INVENTION

The object of the present invention is to overcome the problems mentioned above and improve the information offer to persons
35 visiting a foreign place.

This object is obtained by the device initially defined, which comprises a portable unit for each user, at least one central unit with a computer, first means, which are arranged to enable communication from at least one producer of said service to said central unit, second means, which are arranged to determine the geographic position of substantially each portable unit, and third means which are arranged to enable communication in both directions between each portable unit and the central unit via a wireless communication network, wherein the central unit is arranged to provide said service to the portable units fulfilling a certain criterion with respect to said geographic position.

This criterion can be determined by for instance the producer who wants to reach every user within one or several determined areas during a certain period of time with a piece of information. By means of the computerised central unit and the wireless communication network, which for instance may include a cellular mobile telephone network, the information in question may be transmitted from the central unit only to the users who the producer wishes to reach. The thought is that each user, such as a tourist or another visitor of a foreign place, for a suitable fee is allotted such a portable unit by which the user may get access to several different services, for instance information in the form of a description of a geographic area, in which the portable unit is located, or a menu of a selection of different services or products which are offered within said area. It is to be noted that the expression "information" is to be broadly interpreted and to include all messages, which are desired to be received and/or transmitted, for instance advertisement for a product which is sold by said producer.

According to an embodiment of the invention, the central unit is connected to a database, which is arranged to store said geographic position for each portable unit. Thereby, the device may advantageously be arranged to update said geographic position in the database according to a certain algorithm in such a manner that the central unit via the database always has access to substantially

correct information about the position of substantially each portable unit. In such a manner it is possible to transmit information to one single determined user of the device.

5 According to a further embodiment of the invention, the database is arranged to store at least one individual-related parameter regarding at least a part of said number of portable units. Such an individual-related parameter may include at least one individual
10 desire of the user in question, which is communicable via the portable unit and the central unit to the database.

According to a further embodiment of the invention, said portable unit includes a displaying member for disclosing the information. Furthermore, said portable unit may include a memory unit for
15 storing said information.

According to a further embodiment of the invention, said service includes providing information from said producer via the central unit which is arranged to transmit the information in question to said
20 portable unit. For instance, a producer, in the form of a manufacturer or salesman, may provide information such as for instance advertisement for said products. Thereby, the central unit may be arranged to provide said information to a selection of said users and to determine said selection with regard to said individual-
25 related parameters. The information may also include a map of a geographic area, in which the portable unit is located or a menu over a selection of services which are provided by said producer, such as services provided by at least one of a restaurant, a museum, a theatre, a cinema.

30

According to further embodiments of the invention, the central unit may be either substantially stationary or mobile.

The object is also obtained by the method initially defined, which
35 includes the steps of:

- connecting at least one producer of said service to said central unit,

- allotting to each user a respective portable unit which includes means for two-way communication with the central unit via a wireless communication network,

- determining the geographic position for substantially each portable unit, and

- providing said service to the portable units which fulfil a certain criterion with respect to said geographic position.

According to one embodiment of the method according to the invention, said service is ordered via one of said portable units and delivered to the geographic position at which the portable unit in question is located.

BRIEF DESCRIPTION OF THE DRAWINGS

15

The invention is now to be described by means of different embodiments and with reference to the drawings attached, in which Fig 1 discloses schematically the different main components included by the device,

20 Fig 2 discloses a portable unit included by the device, and

Fig 3 discloses schematically different components included by the portable unit.

25 DETAILED DESCRIPTION OF DIFFERENT EMBODIMENTS OF THE INVENTION

Fig 1 discloses schematically the structure of a device according to the present invention. The device, which forms a system of different components, includes a great number of portable units 1 which each is intended to be allotted to a user, such as a tourist or any other visitor, who wishes to utilise the device or the system. Each portable unit is arranged to communicate with a central unit 2 via a wireless communication network, which may be formed by a cellular mobile telephone network, for instance the GSM network. The wireless communication network includes a communication unit 3, which is connected to the central unit 2. The communication unit 3 and the portable units 1 may thus be formed by an existing cellular

mobile telephone network, wherein the different portable units may communicate with each other over the existing cellular mobile telephone network.

5 According to the present invention, the device includes means for determining the geographic position of substantially each portable unit 1. Such a position determination may be performed in different manners, for instance by means of a global position-determining system (GPS), wherein each portable unit 1 includes a receiver 4,
10 see Figs 2 and 3, which via an antenna 4a is arranged to receive a position-determination from a GPS satellite 5. The position received is transmitted via the communication unit 3 to the central unit 2 which is arranged to store the position of the portable unit 1 in question in a suitable datastoring medium in a database 6. The
15 position of each portable unit 1 may also be determined in other ways, for instance the GSM-system as such offers certain possibilities of position-determination of the portable unit 1 communicating with the system.

20 Each portable unit 1, see Figs 2 and 3, includes a local computer 7 with a memory member 8. Furthermore, each unit includes a display member 9, preferably in the form of a so-called LCD-screen. Furthermore, each unit 1 includes a communication unit 10, which is connected to the local computer 7 and via an antenna 10a is
25 arranged to communicate data and possibly speech (via a microphone/loudspeaker 10b) with the central unit 2 and/or one or several other portable units 1 via said communication unit 3, and input members, for instance in the form of a key set 11 and a so-called control pen 12 for the input via the display member 9.

30 The central unit 2 includes a relatively powerful computer 13, which communicates with the database 6. Furthermore, the central unit 2 is arranged to communicate with one or several producers 14 of different products and services. This communication may be
35 performed via a communication unit 15, which may be formed by a wireless communication network, for instance a cellular mobile telephone network, merely a keyboard or any other input member to

the computer 13 of the central unit 2. It is to be noted here that several different producers 14 may share a central unit 2 which administers the information which the producers 14 want to communicate with different portable units 1 or users, but it is also possible within the device according to the invention to arrange several central units 2, 2', see Fig 1, wherein certain producers 14 may utilise a central unit 2' proper, which in its turn includes a database 6' proper and a computer 13' proper. According to a further possible embodiment of the invention, several different central units 2, 2' may co-operate with one and the same database 6 (not disclosed). The central unit 2, 2' may be designed as a stationary unit but it is also possible to design one or several central units as mobile units, which for instance follow a group of users during a journey.

The definition producer 14 is to be broadly interpreted, i.e. it includes all persons or organisations which wish to provide services to the users defined above. Also, the definition service is to be broadly interpreted in the present application and includes information and the communication which may be advantageous or necessary in connection with providing different services or products. Producers 14 may for instance be a tourist information agency which wishes to provide maps of areas, appropriate information about different events, which are to take place within an area, a menu of different interesting places or other cultural things worth seeing. Other possible producers 14 may be a hotel providing information about for instance free rooms, a restaurant providing a menu over the offers of today, a museum, a theatre providing information about the actual program, a cinema, stores providing information about actual products and prices etc.

The central unit 2, 2' is advantageously arranged to update the geographic position of each portable unit 1 according to a determined algorithm. For instance, the geographic position may be updated each time a portable unit 1 communicates with the central unit 2, 2'. Another possibility is to update the geographic position at regular time intervals or each time the positioning system 5 detects

a movement of the unit 1 in question, wherein the movement preferably has a minimum determined size.

5 The database 6, 6' may also be arranged to store other information regarding each portable unit 1 or user than the geographic position. For instance, the database 6, 6' may store different individual-related parameters, which include one or several individual desires of the user in question. Consequently, a user may, when he gets access to the portable unit via the communication unit 3 and the
10 central unit 2, 2', define different desires regarding for instance the type of information desired.

Consequently, the central unit 2, 2' is arranged to provide information from said producers 14 to the portable units 1 with
15 regard to the geographic position of each individual unit 1 and the individual-related parameters. One producer 14 may for instance wish to provide advertisement for a product or a service to the users located within a determined geographic area. Such a desire from the producer 14 in question may easily be satisfied since the
20 central unit 2, 2' has access to the geographic position of substantially all portable units 1.

The device offers many advantages and there is a great number of examples of how it may be used. A producer 14 may for instance be
25 a taxi company, which is connected to the device, and a user may, via his portable unit 1, get access to a taxi merely by defining that a taxi is desired. Since the central unit 2, 2' knows the position of the user in question, it may communicate an order to the producer 14, i.e. the taxi company, to send a taxi to the position where the user
30 in question is located. The system also offers the possibility to determine in a rational and efficient manner which taxi is to perform said order since there is an appropriate knowledge about the position of the user in question.

35 Another example of how the device may be utilised is that the different users may find out the geographic position of other users

via the communication unit 3 and the geographic positions, which are stored in the database 6, 6'.

5 The invention is not limited to the embodiments described above but may be varied and modified within the scope of the following claims.

Claims

1. A device for providing at least one service to at least one of a number of users who are connected to the device, wherein the device includes a portable unit (1) for each user, at least one central unit (2, 2') having a computer (13, 13'), first means (15), which are arranged to enable communication from at least one producer (14) of said service to said central unit (2, 2'), second means (5), which are arranged to determine the geographic position of substantially every portable unit (1), and third means (3) arranged to enable communication in both directions between each portable unit (1) and said central unit (2) via a wireless communication network, wherein the central unit (2, 2') is arranged to provide said service to the portable units (1) fulfilling a certain criterion with respect to said geographic position.
2. A device according to claim 1, characterised in that the central unit (2, 2') is connected to a database (6, 6') which is arranged to store said geographic position for each portable unit (1).
3. A device according to claim 2, characterised in that it is arranged to update said geographic position in the database (6, 6') according to a certain algorithm in such a manner that the central unit (2, 2') via the database (6, 6') always has access to substantially correct information about the position of substantially each portable unit (1).
4. A device according to any one of the preceding claims, characterised in that the database (6, 6') is arranged to store at least one individual-related parameter regarding at least one of said number of portable units (1).
5. A device according to claim 4, characterised in that said individual-related parameter includes at least an individual desire of the user in question which is communicable via the portable unit (1) and the central unit (2, 2') to the database (6, 6').

6. A device according to any one of the preceding claims, characterised in that said portable unit (1) includes a display member (9) for disclosing information.
- 5
7. A device according to claim 6, characterised in that said portable unit (1) includes a memory unit (8) for storing said information.
- 10
8. A device according to any one of the preceding claims, characterised in that said service includes providing information from said producer (14) via the central unit (2, 2') which is arranged to transmit the information in question to said portable unit (1).
- 15
9. A device according to claims 4 and 8, characterised in that the central unit (2, 2') is arranged to provide said information to a selection of said users, wherein the central unit (2, 2') is arranged to decide said selection with respect to said individual-related parameter.
- 20
10. A device according to any one of claims 6-9, characterised in that said information includes a map of a geographic area in which the portable unit (1) is located.
- 25
11. A device according to any one of claims 6-10, characterised in that said information includes a menu of a selection of services, which are provided by, said producer (14).
- 30
12. A device according to claim 11, characterised in that said information includes services which are provided by at least one of a restaurant, a museum, a theatre, a cinema.
- 35
13. A device according to any one of claims 6-12, characterised in that said information includes information about at least one product which is provided by said producer (14).

14. A device according to any one of the preceding claims, characterised in that said central unit (2, 2') is stationary.

5 15. A device according to any one of the preceding claims, characterised in that said central unit (2, 2') is mobile.

10 16. A device according to any one of the preceding claims, characterised in that said communication network (3) includes a present cellular mobile telephone network.

15 17. A method for providing at least one service to at least a number of users by means of at least one central unit which includes a computer, including the steps of

- connecting at least one producer of said service to said central unit,
- allotting to each user a respective portable unit which includes means for two-way communication with the central unit via a wireless communication network,
- determining the geographic position for substantially each portable unit, and

20 -providing said service to the portable units, which fulfil a certain criterion with respect to said geographic position.

25 18. A method according to claim 17, characterised in that said service is ordered via one of said portable units and delivered to the geographic position at which the portable unit in question is located.

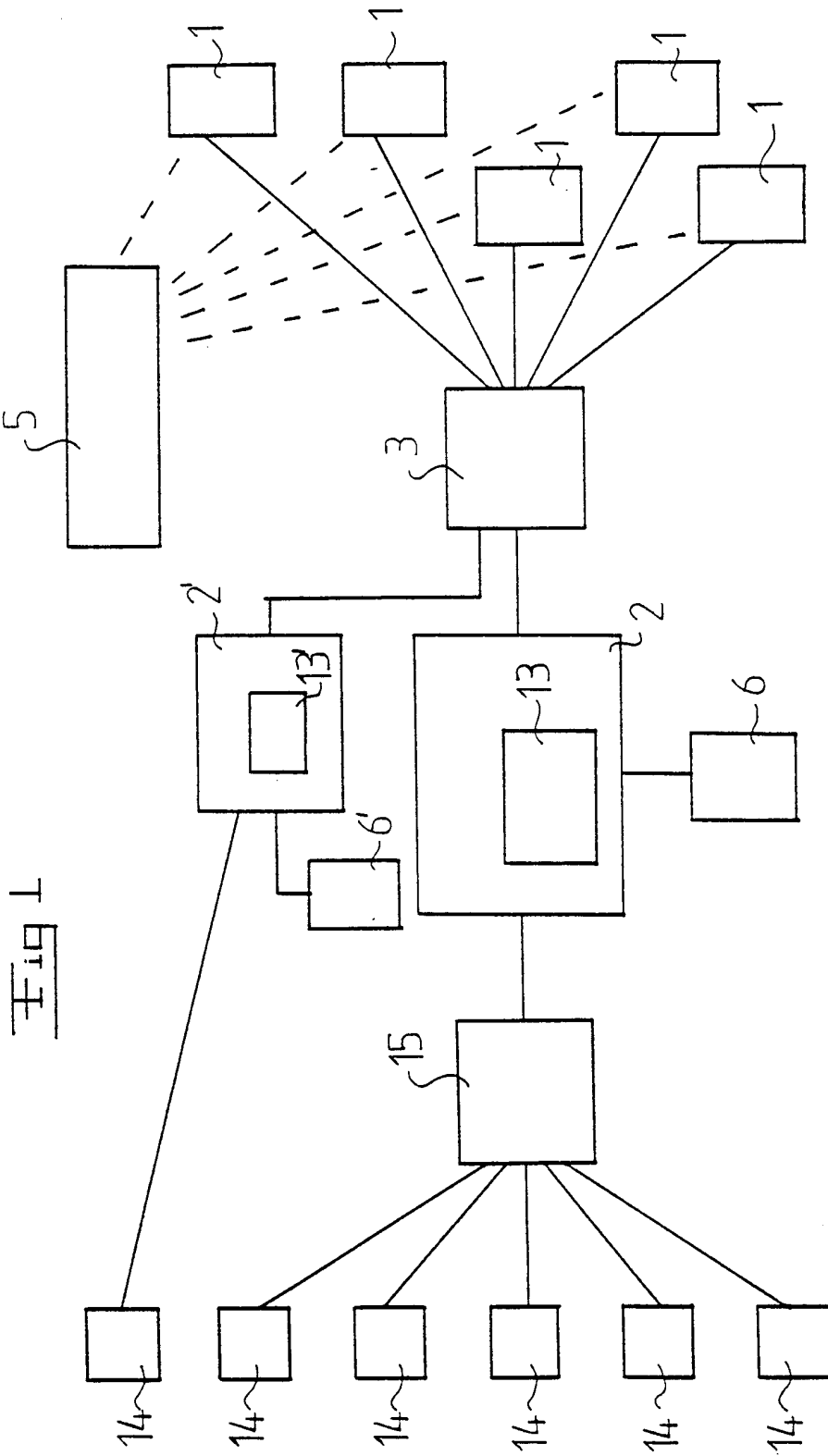

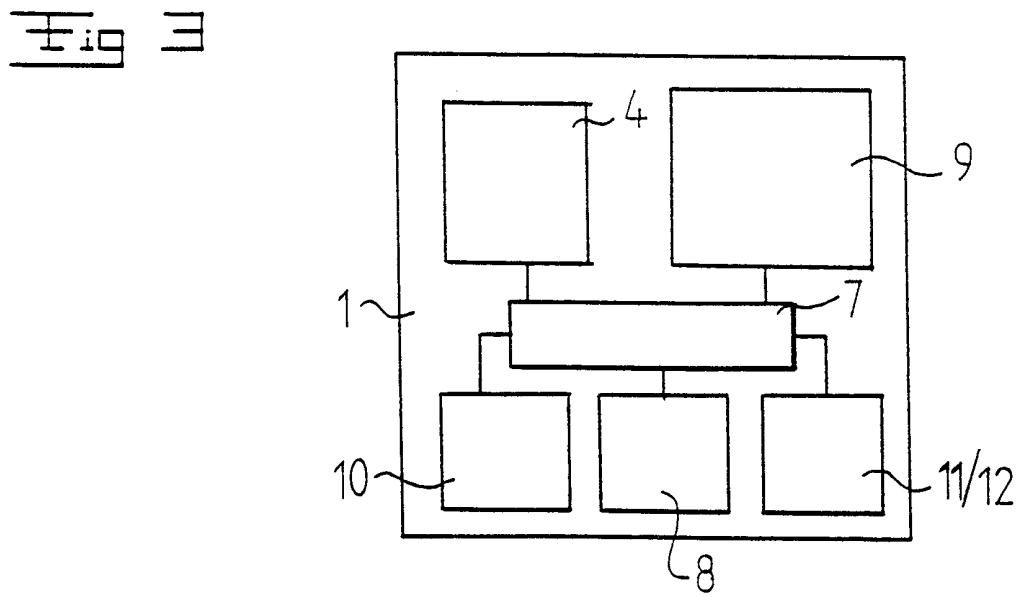
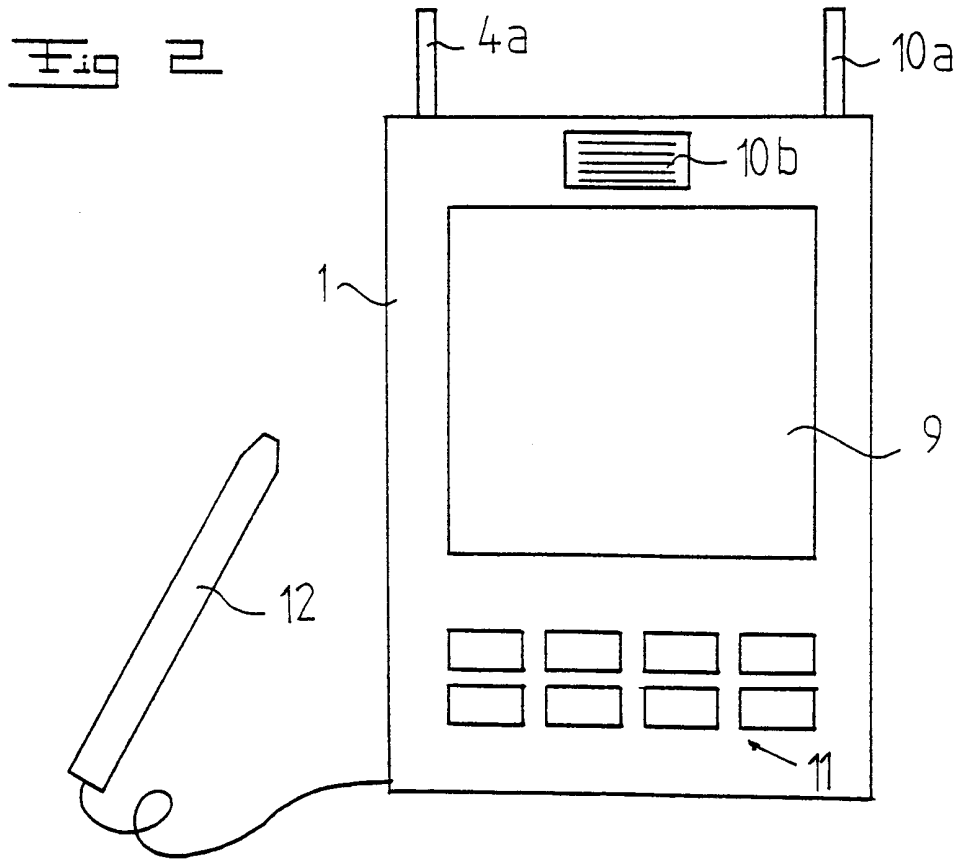

INTERNATIONAL SEARCH REPORT

International application No.

PCT/SE 99/01081

A. CLASSIFICATION OF SUBJECT MATTER

IPC6: G09B 29/10

According to International Patent Classification (IPC) or to both national classification and IPC

B. FIELDS SEARCHED

Minimum documentation searched (classification system followed by classification symbols)

IPC6: G09B, G01C

Documentation searched other than minimum documentation to the extent that such documents are included in the fields searched

SE,DK,FI,NO classes as above

Electronic data base consulted during the international search (name of data base and, where practicable, search terms used)

WPI, EPODOC

C. DOCUMENTS CONSIDERED TO BE RELEVANT

Category*	Citation of document, with indication, where appropriate, of the relevant passages	Relevant to claim No.
P,A	WO 9835333 A1 (CASIO COMPUTER CO., LTD.), 13 August 1998 (13.08.98), the whole document --	1-18
A	WO 9730430 A1 (NATALINI, G. ET AL), 21 August 1997 (21.08.97), the whole document --	1-18
A	EP 0539143 A2 (PIONEER ELECTRONIC CORPORATION), 28 April 1993 (28.04.93), the whole document --	1-18
A	GB 2287535 A (UNIVERSITY OF SURREY), 20 Sept 1995 (20.09.95), the whole document --	1-18

 Further documents are listed in the continuation of Box C.
 See patent family annex.

* Special categories of cited documents:

"A" document defining the general state of the art which is not considered to be of particular relevance

"E" earlier document but published on or after the international filing date

"I" document which may throw doubts on priority claim(s) or which is cited to establish the publication date of another citation or other special reason (as specified)

"O" document referring to an oral disclosure, use, exhibition or other means

"P" document published prior to the international filing date but later than the priority date claimed

"T" later document published after the international filing date or priority date and not in conflict with the application but cited to understand the principle or theory underlying the invention

"X" document of particular relevance: the claimed invention cannot be considered novel or cannot be considered to involve an inventive step when the document is taken alone

"Y" document of particular relevance: the claimed invention cannot be considered to involve an inventive step when the document is combined with one or more other such documents, such combination being obvious to a person skilled in the art

"&" document member of the same patent family

Date of the actual completion of the international search

15 Sept 1999

Date of mailing of the international search report

18-10-1999

Name and mailing address of the ISA

Swedish Patent Office
Box 5055, S-102 42 STOCKHOLM
Facsimile No. +46 8 666 02 86

Authorized officer

Johan Winther / MR
Telephone No. +46 8 782 25 00

INTERNATIONAL SEARCH REPORT

International application No.

PCT/SE 99/01081

C (Continuation). DOCUMENTS CONSIDERED TO BE RELEVANT

Category*	Citation of document, with indication, where appropriate, of the relevant passages	Relevant to claim No.
A	US 5067081 A (C.E. PERSON), 19 November 1991 (19.11.91), the whole document --	1-18
A	US 5696684 A (H.-J. UEBERSCHAER), 9 December 1997 (09.12.97), the whole document -- -----	1-18

INTERNATIONAL SEARCH REPORT

Information on patent family members

30/08/99

International application No.

PCT/SE 99/01081

Patent document cited in search report	Publication date	Patent family member(s)	Publication date
WO 9835333 A1	13/08/98	CN 1216132 A	05/05/99
		EP 0901676 A	17/03/99
		JP 10222057 A	21/08/98
		JP 10320597 A	04/12/98
-----	-----	-----	-----
WO 9730430 A1	21/08/97	NONE	
-----	-----	-----	-----
EP 0539143 A2	28/04/93	DE 69218548 D,T	02/10/97
		EP 0747670 A,B	11/12/96
		JP 5113752 A	07/05/93
		JP 5113753 A	07/05/93
		JP 5113754 A	07/05/93
-----	-----	-----	-----
GB 2287535 A	20/09/95	GB 9405210 D	00/00/00
		GB 9505478 D	00/00/00
-----	-----	-----	-----
US 5067081 A	19/11/91	NONE	
-----	-----	-----	-----
US 5696684 A	09/12/97	DE 4122398 A	07/01/93
		DE 59203916 D	00/00/00
		EP 0592524 A,B	20/04/94
		JP 7505231 T	08/06/95
		WO 9301469 A	21/01/93
-----	-----	-----	-----