



(51) International Patent Classification:
A43C 17/00 (2006.01)

(21) International Application Number:

PCT/US2014/038982

(22) International Filing Date:

21 May 2014 (21.05.2014)

(25) Filing Language:

English

(26) Publication Language:

English

(30) Priority Data:

61/825,873 21 May 2013 (21.05.2013) US
61/825,864 21 May 2013 (21.05.2013) US

(71) Applicant: **ARIAT INTERNATIONAL, INC.** [US/US];
3242 Whipple Road, Union City, California 94587 (US).

(72) Inventors: **MONROY, Jose Rafael**; 750 N. Shoreline
Blvd., Apt. 165, Mountain View, California 94043 (US).
GROTT, Marco Aurelio; 3326 Amillo Court, Pleasanton,
California 94566 (US). **CONDIT, Austin C.F.**; 352 Alisal

Mesa Road, Solvang, California 93463 (US). **BUCK IV, Calvin Myron**; 13314 SE 19th Street, Apt S # 5, Vancouver, Washington 98683 (US).

(74) Agents: **CHANG, James K.** et al.; Kilpatrick Townsend & Stockton LLP, Eighth Floor, Two Embarcadero Center, San Francisco, California 94111 (US).

(81) Designated States (unless otherwise indicated, for every kind of national protection available): AE, AG, AL, AM, AO, AT, AU, AZ, BA, BB, BG, BH, BN, BR, BW, BY, BZ, CA, CH, CL, CN, CO, CR, CU, CZ, DE, DK, DM, DO, DZ, EC, EE, EG, ES, FI, GB, GD, GE, GH, GM, GT, HN, HR, HU, ID, IL, IN, IR, IS, JP, KE, KG, KN, KP, KR, KZ, LA, LC, LK, LR, LS, LT, LU, LY, MA, MD, ME, MG, MK, MN, MW, MX, MY, MZ, NA, NG, NI, NO, NZ, OM, PA, PE, PG, PH, PL, PT, QA, RO, RS, RU, RW, SA, SC, SD, SE, SG, SK, SL, SM, ST, SV, SY, TH, TJ, TM, TN, TR, TT, TZ, UA, UG, US, UZ, VC, VN, ZA, ZM, ZW.

(84) Designated States (unless otherwise indicated, for every kind of regional protection available): ARIPO (BW, GH,

[Continued on next page]

(54) Title: BOOTS WITH SPUR STABILITY SYSTEM

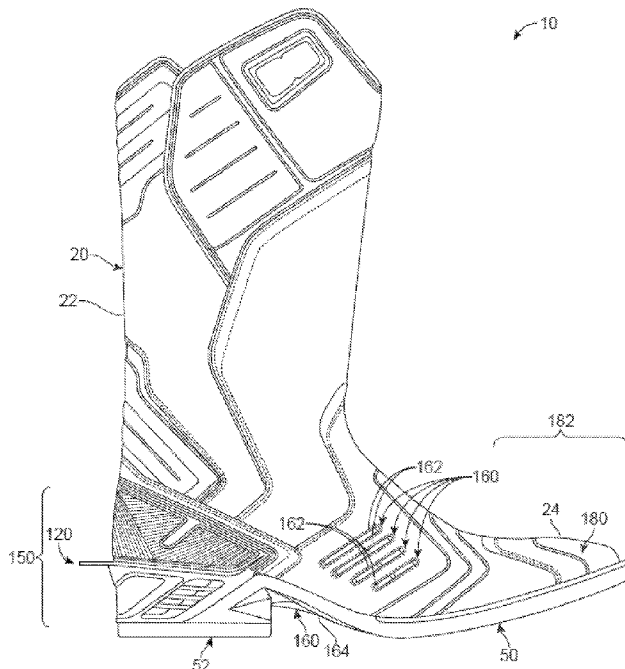

FIG. 4

(57) Abstract: Boots with spur stability systems are disclosed herein. A spur stability system can be configured to couple with a boot having an upper and an outsole, where the spur stability system includes at least one strap stability structure that is configured to resist motion of a spur strap relative to the boot when a spur is operatively attached to the boot with the spur strap. The spur stability system can have an upper strap coupled to the spur, in contact with at least one stability structure on the external surface of the upper. The spur stability system can additionally have a lower strap coupled to the spur, in contact with at least one stability structure on the external surface of the outsole.

WO 2014/190061 A1



GM, KE, LR, LS, MW, MZ, NA, RW, SD, SL, SZ, TZ, UG, ZM, ZW), Eurasian (AM, AZ, BY, KG, KZ, RU, TJ, TM), European (AL, AT, BE, BG, CH, CY, CZ, DE, DK, EE, ES, FI, FR, GB, GR, HR, HU, IE, IS, IT, LT, LU, LV, MC, MK, MT, NL, NO, PL, PT, RO, RS, SE, SI, SK, SM, TR), OAPI (BF, BJ, CF, CG, CI, CM, GA, GN, GQ, GW, KM, ML, MR, NE, SN, TD, TG).

Published:

- *with international search report (Art. 21(3))*
- *before the expiration of the time limit for amending the claims and to be republished in the event of receipt of amendments (Rule 48.2(h))*

BOOTS WITH SPUR STABILITY SYSTEM

CROSS-REFERENCES TO RELATED APPLICATIONS

[0001] The present application claims priority to U.S. provisional patent application 61/825,873 and U.S. provisional patent application 61/825,864, both filed on May 21, 2013,
5 which are hereby incorporated by reference.

FIELD OF THE DISCLOSURE

[0002] The present disclosure is directed to footwear, and more particularly to boots that include a spur stability system.

10

BACKGROUND OF THE INVENTION

[0003] Wearers of western and/or equestrian boots often may utilize spurs, which are tools that may be operatively attached, or coupled, to the wearer's boot and positioned for engaging and/or directing a horse. Spurs typically have a yoke that wraps partially around a
15 rear portion of the boot and that is attached to the boot by one or more straps. This yoke additionally or alternatively may be referred to as a band or a heel band. While a wearer is riding a horse, the spurs may move and/or translate relative to the wearer's boot, thereby decreasing their effectiveness. Thus, there exists a need for boots with a spur stability system.

20

BRIEF SUMMARY OF THE INVENTION

[0004] A spur stability system as disclosed herein can be configured to couple with a boot having an upper and an outsole, where the spur stability system includes at least one strap stability structure that is configured to resist motion of a spur strap relative to the boot when a
25 spur is operatively attached to the boot with the spur strap. The spur stability system can have an upper strap coupled to the spur or spur yoke, in contact with at least one stability structure on the external surface of the upper. The spur stability system can additionally have a lower strap coupled to the spur or spur yoke, in contact with at least one stability structure on the external surface of the outsole.

30

[0005] Illustrative, non-exclusive examples of systems and methods according to the present disclosure are presented below. In some embodiments, a boot can include an upper

that defines a shaft and a shell which is configured to receive a wearer's foot, an outsole that is operatively attached to the upper and configured to contact a ground surface when the wearer wears the boot, and a spur stability system that includes at least one strap stability structure that is configured to resist motion of a spur strap relative to the boot when a spur is

5 operatively attached to the boot with the spur strap. In some aspects, the boot strap stability structure can include an upper strap stability structure that is either or both (i) operatively attached to the upper and (ii) forms a portion of the upper. In other aspects, the upper strap stability structure is configured to resist motion of an upper spur strap that, when present, extends across the upper in contact with the upper strap stability structure. In further aspects,

10 the upper strap stability structure can extend from a surface of the upper to contact one or more upper spur straps. In some aspects, the strap stability structure can include a lower strap stability structure that is either or both (i) operatively attached to the outsole and (ii) forms a portion of the outsole.

[0006] In some aspects a boot having a lower strap stability structure can be configured to

15 resist motion of a lower spur strap that, when present, extends across the outsole in contact with the lower strap stability structure. In other aspects, the lower strap stability structure can extend from a surface of the outsole to contact a/the lower spur strap. In further aspects, the spur stability system can include a spur rest that is configured to support a yoke of the spur. In some aspects, a boot having a spur rest can be located at least partially between the yoke

20 and the outsole when the spur is operatively attached to the boot. In other aspects, the spur rest is sized to resist motion toward the outsole by a portion of the yoke that is in contact with the spur seat. In further aspects, the spur rest can be defined by a protrusion that extends from a surface of the boot. In some aspects, the boot can further include an abrasion-resistant toe region that is selected to resist damage to a toe region of the boot. In such aspects, the

25 abrasion-resistant toe region can be formed from an abrasion-resistant material that is operatively attached to the upper. In further aspects, the abrasion-resistant toe region can be formed from a different material than (at least a portion of) a remainder of the upper.

[0007] In some aspects, a boot having a strap stability structure can be defined by a

30 stability structure material that is selected to have a high coefficient of static friction with the spur strap. In such aspects, a coefficient of static friction between the stability structure material and the spur strap is at least a threshold multiple larger than a coefficient of static friction between a remainder of the upper and the spur strap, where the threshold multiple can be at least 2, at least 3, at least 4, at least 5, at least 6, at least 8, or at least 10 times larger

than the coefficient of static friction between the remainder of the upper and the spur strap. In some aspects, the strap stability structure is formed from at least one of a resilient material, a flexible material, an abrasion-resistant material, and a high-friction material. In other aspects, the strap stability structure is formed from a material that is either or both (i) grips the spur strap, and (ii) conforms to a surface of the spur strap. In further aspects, the strap stability structure can be formed from at least one of a polymeric material and an elastomeric material. In some aspects, the strap stability structure defines any one or a combination of (i) a plurality of raised projections, (ii) a plurality of raised ribs, and (iii) a plurality of raised ridges. In some aspects, the strap stability structure can be configured to be compressed between the spur strap and the boot.

[0008] These and other features, aspects, and advantages are described below with reference to the following drawings, and will become better understood when the following detailed description is read with reference to the accompanying drawings.

BRIEF DESCRIPTION OF THE DRAWINGS

[0009] FIG. 1 is a schematic representation of illustrative, non-exclusive examples of a boot that includes a spur stability system according to the present disclosure.

[0010] FIG. 2 is a schematic representation of illustrative, non-exclusive examples of the boot of FIG. 1 with an attached spur.

[0011] FIG. 3 is a schematic illustration of non-exclusive examples of a side view of a boot that includes a spur stability system according to the present disclosure.

[0012] FIG. 4 is a schematic illustration of a non-exclusive example of an opposed side view of the boot of FIG. 3.

[0013] FIG. 5 is a schematic illustration of a non-exclusive example of a top view of a toe region of the boot of FIGS. 3-4.

[0014] FIG. 6 is a schematic illustration of a non-exclusive example of an upper strap stability structure according to the present disclosure.

[0015] FIG. 7 is a schematic illustration of non-exclusive examples of an outer surface of an outsole that includes a lower strap stability structure according to the present disclosure.

DETAILED DESCRIPTION OF THE INVENTION

[0016] Throughout this description for the purposes of explanation, numerous specific details are set forth in order to provide a thorough understanding of the many embodiments disclosed herein. It will be apparent, however, to one skilled in the art that the many
5 embodiments may be practiced without some of these specific details. In other instances, well-known structures and devices are shown in diagram or schematic form to avoid obscuring the underlying principles of the described embodiments.

[0017] Western-style and equestrian boots often use spurs, which are tools that can be mechanically attached or coupled to a boot, and positioned for engaging and/or directing a
10 horse. Spurs generally have a yoke that wraps partially around a rear portion of the boot and that is attached to the boot by one or more straps. The yoke, or yoke straps, can be further secured to the boot through the use of a spur stability system, constructed into the exterior structure of the boot. In various embodiments, a spur stability system can include, independently or in combination: strap stability structures on the upper portion of the boot
15 (e.g. on the vamp or shell) that have a coefficient of friction greater than that of the remainder of the upper that engages with parts of the yoke or straps and generally prevents unwanted movement of the yoke or straps; strap stability structures on the outsole of the boot that have a coefficient of friction greater than that of the remainder of the outsole that engages with parts of the yoke or straps and generally prevents unwanted movement of the yoke or straps;
20 and ridges, ribs, or protrusions along the upper of the boot, which can provide for spaces in which the yoke or straps can rest and be secured, or can act as a biasing member against forces that may otherwise cause the spur or yoke to move in an unwanted direction while coupled to the boot.

[0018] FIGS. 1-7 provide illustrative, non-exclusive examples of a boot 10, or portions
25 thereof, that include a spur stability system 150 according to the present disclosure. Elements that serve a similar, or at least substantially similar, purpose are labeled with like numbers in each of FIGS. 1-7, and these elements may not be discussed in detail herein with reference to each of FIGS. 1-7. Similarly, all elements may not be labeled in each of FIGS. 1-7, but reference numerals associated therewith may be utilized herein for consistency. Elements,
30 components, and/or features that are discussed herein with reference to one or more of FIGS. 1-7 may be included in and/or utilized with any of FIGS. 1-7 without departing from the scope of the present disclosure.

[0019] In general, elements that are likely to be included in a given (i.e., a particular) embodiment are illustrated in solid lines, while elements that are optional to a given embodiment are illustrated in dashed lines. However, elements that are shown in solid lines are not essential to all embodiments, and an element shown in solid lines may be omitted
5 from a particular embodiment without departing from the scope of the present disclosure.

[0020] FIG. 1 is a schematic representation of illustrative, non-exclusive examples of a boot
10 that includes a spur stability system 150 according to the present disclosure, while FIG. 2 is a schematic representation of the boot of FIG. 1 with an attached spur 90. In FIGS. 1-2, boot 10 includes an upper 20, an outsole 50, and spur stability system 150. Spur stability system 150 includes at least one strap stability structure 160, which is configured to resist motion of a spur strap 94 relative to the boot when spur 90 is operatively attached to the boot with the spur strap (as illustrated in FIG. 2). Spur stability system 150 optionally may include a spur rest 120 (which can alternatively be referred to as a spur ledge or a spur seat). In aspects, the spur stability structure 160 can include more than one spur strap 94, which in
15 further aspects can include an upper spur strap 96 and a lower spur strap 98.

[0021] Strap stability structure 160 may include an upper strap stability structure 162 that may be operatively attached to, formed by, and/or form a portion of upper 20. Upper strap stability structure 162 may be selected, sized, designed, constructed, and/or configured to resist a motion of an upper spur strap 96 that may extend across and/or around upper 20 and in contact with the upper strap stability structure when spur 90 is operatively attached to boot
20 10 (as illustrated in FIG. 2). As an illustrative, non-exclusive example, upper strap stability structure 162 may project or otherwise extend from an external surface 14 of boot 10 (or upper 20 thereof) to contact, interface with, and/or decrease a motion of upper spur strap 96. As discussed herein, the upper strap stability structure 162 may frictionally engage and limit
25 relative sliding movement of the upper spur strap 96 relative to the external surface of the boot. Moreover, the upper strap stability structure 162 may frictionally engage and limit relative sliding movement to a greater extent than the portions of the external surface of the boot that are adjacent, and optionally immediately adjacent, to the upper strap stability structure 162.

[0022] Additionally or alternatively, strap stability structure 160 also may include a lower strap stability structure 164 that may be operatively attached to, formed by, and/or form a portion of outsole 50. Lower strap stability structure 164 may be selected, sized, designed,
30

constructed, and/or configured to resist a motion of a lower spur strap 98 that may extend across and/or around outsole 50 (or an arch region 65 thereof) and in contact with the lower strap stability structure when spur 90 is operatively attached to boot 10 (as illustrated in FIG. 2). As an illustrative, non-exclusive example, lower strap stability structure 164 may project or otherwise extend from external surface 14 of boot 10 (or an outer surface 68 of outsole 50) to contact, interface with, and/or decrease a motion of lower spur strap 98. As discussed herein, the lower strap stability structure 164 may frictionally engage and limit relative sliding movement of the lower spur strap 98 relative to the external surface of the boot. Moreover, the lower strap stability structure 164 may frictionally engage and limit relative sliding movement to a greater extent than the portions of the external surface of the boot that are adjacent, and optionally immediately adjacent, to the lower strap stability structure 164.

[0023] Regardless of the location of strap stability structure 160 on and/or within boot 10, the strap stability structure 160 may include and/or be defined by a stability structure material that is adapted, configured, formulated, synthesized, and/or selected to have a high coefficient of static friction with spur strap(s) 94. As an illustrative, non-exclusive example, the coefficient of static friction between strap stability structure 160 and strap(s) 94 may be greater than a coefficient of static friction between strap(s) 94 and a remainder of boot 10, upper 20, and/or outsole 50 at least a threshold multiple. As used herein, this “remainder” additionally or alternatively may be referred to as a conventional portion, an adjacent portion, an immediately adjacent portion, and/or a leather portion of the boot, upper, and/or outsole against which a spur strap is in engagement during use of a boot with the corresponding spur and/or against which the spur strap would be in engagement but for the presence of the strap stability structure 160. As illustrative, non-exclusive examples, the coefficient of static friction between strap stability structure 160 and strap(s) 94 may be at least 2, at least 3, at least 4, at least 5, at least 6, at least 8, or at least 10 times larger than the coefficient of static friction between strap(s) 94 and the remainder of boot 10, upper 20, and/or outsole 50.

[0024] As additional illustrative, non-exclusive examples, strap stability structure 160 may include and/or be formed from a resilient material, a flexible material, an abrasion-resistant material, and/or a high-friction material. Additionally or alternatively, strap stability structure 160 also may be formed from a material that grips spur strap(s) 94 and/or conforms to a surface, or surface profile, of spur strap(s) 94. As more specific but still illustrative, non-exclusive examples, strap stability structure 160 may include and/or be a polymeric material and/or an elastomeric material.

[0025] It is within the scope of the present disclosure that strap stability structure 160 may include and/or define any suitable shape and/or conformation. For example, the strap stability structure 160 may include at least one (and optionally a plurality of spaced-apart) strap-stabilizing and/or strap-retaining region, or surface, such as on the top, side, and/or
5 opposed sides of the upper's shell or vamp, and/or on the outsole, such as on the bottom surface, one side, and/or opposed sides of the outsole. As illustrative, non-exclusive examples (and as illustrated in FIG. 6 at 166), the strap stability structure 160 may include and/or be a plurality of raised projections, a plurality of raised ribs, a plurality of raised ridges, a plurality of spaced-apart projections, a plurality of spaced-apart ribs, and/or a
10 plurality of spaced-apart ridges. As another illustrative, non-exclusive example, strap stability structure 160 also may be selected, sized, and/or configured to be compressed between spur strap(s) 94 and a remainder of boot 10, such as to increase a friction between the strap stability structure and the strap(s) and/or to decrease a potential for relative motion between boot 10 and strap(s) 94.

[0026] As discussed, spur stability system 150 also may include spur rest 120, which also may be referred to herein as a spur rest 120. Spur rest 120 may be selected, sized, and/or configured to support a yoke 92 of spur 90 (as illustrated in FIG. 2). As an illustrative, non-exclusive example, spur rest 120 may be located at least partially between yoke 92 and
15 outsole 50, and spur rest 120 may be configured to resist motion of a portion of the yoke 92 that is in contact with the spur rest toward outsole 50. As another illustrative, non-exclusive example, spur rest 120 may include and/or be a stop, rib, and/or other protrusion 122 that extends from external surface 14 of boot 10.
20

[0027] As illustrated in FIGS. 1-2, boot 10 further may include an abrasion-resistant toe region 180 that is adapted, configured, and/or selected to resist damage to a toe region 182 of
25 boot 10. As an illustrative, non-exclusive example, abrasion-resistant toe region 180 may be formed from an abrasion-resistant material 184. As another illustrative, non-exclusive example, abrasion-resistant toe region 180 may be formed from a different material than at least a portion of a remainder of upper 20 and/or may extend over and/or across the portion of the remainder of upper 20.

[0028] Upper 20 may include any suitable structure that is sized, designed, constructed, and/or configured to receive a wearer's foot and may be constructed from any suitable material. This may include any suitable conventional upper that may be utilized in
30

conventional boots. As illustrative, non-exclusive examples, upper 20 may include a shaft 22 and a shell (or vamp) 24, with shaft 22 permitting entry of the wearer's foot into shell 24 and encircling a lower portion of a wearer's leg when the wearer is wearing the boot, and with shell 24 housing the wearer's foot while the wearer is wearing boot 10. Typically, shaft 22 (which additionally or alternatively may be referred to as a chimney) will extend around at least an ankle and an Achilles portion of the wearer's lower leg, with some shafts extending to the wearer's mid-calf and/or to or toward the wearer's knee. As additional illustrative, non-exclusive examples, upper 20 may be constructed from naturally occurring materials, leather, cloth, synthetic materials, and/or polymers. Additional illustrative, non-exclusive examples of uppers 20 that may be utilized with and/or included in boots 10 according to the present disclosure are disclosed in U.S. Patent No. 7,980,010, the complete disclosure of which is hereby incorporated by reference.

[0029] Outsole 50 may include any suitable structure that is sized, designed, constructed, and/or configured to contact the ground surface when the wearer wears boots 10. This may include any suitable conventional outsole that may be utilized in conventional boots. As illustrated in FIGS. 1-2, outsole 50 may include and/or have attached thereto a heel, or heel cap, 52. Heel 52 may be described as a projecting heel, or projecting heel cap, because it extends away from the shaft and defines an engagement surface 63, such as may be used to engage and position the boot within a stirrup. It is within the scope of the present disclosure that outsole 50 may be formed and/or constructed from any suitable material, or combinations of materials, including naturally occurring materials, leather, rubber, synthetic materials, and/or polymers. Further, in some aspects, the structure of the heel 52 can include an extension that is functional as a spur rest 120. As indicated in FIG. 1, outsole 50 may include a shank 64, which supports an arch region 65 of the outsole, and may include and/or be used in combination with a midsole 66 and/or footbed 67, which (when present) are located closer to the wearer's foot when the boot is worn than the remainder of the outsole. The outer (i.e., ground contacting or bottom) surface 68 of outsole 50 and/or heel 52 may optionally include a tread structure. Illustrative, non-exclusive examples of outsoles 50 that may be included in and/or utilized with boots 10 according to the present disclosure are disclosed in U.S. Patent Application Publication Nos. 2010/0126044 and 2011/0271553, the complete disclosures of which are hereby incorporated by reference.

[0030] FIGS. 3-7 are schematic illustrations of non-exclusive examples of boots 10 and/or spur stability systems 150 according to the present disclosure that may include and/or be

boots 10 and/or spur stability systems 150 of FIGS. 1-2. In FIGS. 3-7 locations, orientations, and/or dimensions of boots 10 and/or components thereof may be described in specific detail. These locations, orientations, and/or dimensions represent illustrative, non-exclusive examples of locations, orientations, and/or dimensions according to the present disclosure, and boots 10 and/or components thereof according to the present disclosure are not limited to the illustrated locations, orientations, and/or dimensions (including relative dimensions).

[0031] FIG. 3 is a schematic illustration of a non-exclusive example of a side view of boot 10, while FIG. 4 is an opposed side view of the boot of FIG. 3. As illustrated in FIGS. 3-4 and discussed herein, boots 10 include an upper 20, an outsole 50, and spur stability system 150.

Spur stability system 150 includes a spur rest 120 and strap stability structure 160. Strap stability structure 160 includes upper strap stability structure 162 and lower strap stability structure 164. In aspects, the strap stability structure 160 is made of a rubberized and abrasive material that can grip to spur straps and yoke structures.

[0032] In some aspects as shown, the upper strap stability structure 162 includes a plurality of ridges (alternatively referred to as raised ribs, ridges, and/or projections) extending from the surface of the shell 24. The plurality of ridges defining the upper strap stability structure 162 in such aspects can be of varying length and/or parallel relative to each other. In other aspects, a plurality of ridges defining the upper strap stability structure 162 can be of equal length and/or non-parallel relative to each other. In some aspects, a plurality of ridges defining an upper strap stability structure 162 can include two ridges, three ridges, four ridges, five ridges, or more than five ridges. In some embodiments, an upper strap stability structure 162 can have portions on both the medial side of a boot 10 or shell 24 and on the lateral side of a boot 10 or shell 24. In some aspects, the configuration of an upper strap stability structure 162 on the medial side of a shell 24 can be symmetrical to the configuration of the upper strap stability structure 162 on the lateral side of a shell 24. In other aspects, the configuration of an upper strap stability structure 162 on the medial side of a shell 24 can be asymmetrical to the configuration of the upper strap stability structure 162 on the lateral side of a shell 24.

[0033] FIG. 5 is a schematic illustration of a non-exclusive example of a top view of a toe region 182 of boot 10 of FIGS. 3-4. Toe region 182 is an abrasion-resistant toe region 180 and includes a plurality of regions that are formed from an abrasion-resistant material 184. One or more of these abrasion-resistant regions, such as the illustrated region or regions distal

from the toe region 182, may additionally or alternatively be or form a portion of a strap stability structure 160 of a spur stability system 150.

[0034] In some embodiments, the abrasion-resistant material 184 can be attached to the exterior of a portion of the shell 24 in the toe region 182, thereby forming an abrasion-resistant toe region 180. In some aspects, the abrasion-resistant material 184 can be sewn or welted to the shell. In other aspects, additionally or alternatively, an adhesive can be used to attach the abrasion-resistant material 184 to the shell 24. In other embodiments, the abrasion-resistant material 184 can be manufactured as part of the shell 24. In embodiments as illustrated, the abrasion-resistant toe region 180 can include three distinct sections of abrasion-resistant material 184. In other embodiments, the abrasion-resistant toe region 180 can be configured to have on section of abrasion-resistant material 184, two distinct sections of abrasion-resistant material 184, or more than three distinct sections of abrasion-resistant material 184. In embodiments as illustrated, the abrasion-resistant material 184 can span the full width of the shell 24 across the toe region 182. In other embodiments, abrasion-resistant material 184 can span a portion of the width of the shell 24 across the toe region 182. For example, in some aspects, abrasion-resistant material 184 can be present any one or a combination of on the medial side of a shell 24 in the toe region 182, on the lateral side of a shell 24 in the toe region 182, and on the top surface of a shell 24 in the toe region 182. The abrasion-resistant material 184 can be angled upward along the shape of the shell 24, and further each section of the abrasion-resistant material 184 can have a particular length, as measured between the toe and the heel of the boot, where each element individually and in combination contributes to the ability of the abrasion-resistant material 184 to grip and secure spur straps and yoke structures.

[0035] FIG. 6 is a schematic illustration of a non-exclusive example of an upper strap stability structure 162 according to the present disclosure that may be operatively attached to boot 10 and/or to upper 20 thereof. As illustrated in FIG. 6, upper strap stability structure 162 includes and/or defines a plurality of spaced-apart raised ribs, ridges, and/or projections 166 that may be sized to extend from a surface of upper 20 and/or to contact upper spur strap 96 (as illustrated in FIG. 2).

[0036] In some aspects, as seen along the cross-sectional view 163 of the upper strap stability structure 162 taken along the line A-A, where the upper strap stability structure 162 is defined by a plurality of spaced-apart ridges 166, the individual ridges can each extend

about 0.5 mm to about 3.5 mm from the surface of an upper. In other aspects, the individual ridges can each be about 2.5 mm to about 3.5 mm in thickness (where the thickness of the ridge is measured along a primarily vertical axis of a boot 10). In further aspects, the individual ridges can have a width that is about the length of a section of strap stability structure 160 that is attached or adhered to a shell 24 (where the thickness of the ridge is measured along a primarily longitudinal axis of a boot 10). In some aspects, an individual ridge of a plurality of spaced-apart ridges 166 can be about 0.5 cm to about 1.5 cm distant from an adjacent individual ridge.

[0037] FIG. 7 is a schematic illustration of non-exclusive examples of an outer surface 68 of an outsole 50 that includes a lower strap stability structure 164 according to the present disclosure. As illustrated in FIG. 7, lower strap stability structure 164 may be associated with, defined by, defined on, and/or operatively attached to any suitable portion of outer surface 68, such as a portion of outer surface 68 that is within arch region 65.

[0038] In some aspects, the lower strap stability structure 164 can include a projection that projects about 0.5 to 1.5 mm outward from the outer surface 68 of an outsole 50. In other aspects, a projection of the lower strap stability structure 164 can have a width (as measured between the medial and lateral sides of a boot 10) of from about 1 cm to about 4 cm. In further aspects, the lower strap stability structure 164 can include sections on either or both of the lateral and medial sides of the outsole 50 that project inward toward the centerline of a boot 10, providing for spaces in which a lower spur strap 98 can secure or rest when a spur 90 is attached to the boot 10.

[0039] As used herein, the term “and/or” placed between a first entity and a second entity means one of (1) the first entity, (2) the second entity, and (3) the first entity and the second entity. Multiple entities listed with “and/or” should be construed in the same manner, i.e., “one or more” of the entities so conjoined. Other entities may optionally be present other than the entities specifically identified by the “and/or” clause, whether related or unrelated to those entities specifically identified. Thus, as a non-limiting example, a reference to “A and/or B,” when used in conjunction with open-ended language such as “comprising” may refer, in one embodiment, to A only (optionally including entities other than B); in another embodiment, to B only (optionally including entities other than A); in yet another embodiment, to both A and B (optionally including other entities). These entities may refer to elements, actions, structures, steps, operations, values, and the like.

[0040] As used herein, the phrase “at least one,” in reference to a list of one or more entities should be understood to mean at least one entity selected from any one or more of the entity in the list of entities, but not necessarily including at least one of each and every entity specifically listed within the list of entities and not excluding any combinations of entities in the list of entities. This definition also allows that entities may optionally be present other than the entities specifically identified within the list of entities to which the phrase “at least one” refers, whether related or unrelated to those entities specifically identified. Thus, as a non-limiting example, “at least one of A and B” (or, equivalently, “at least one of A or B,” or, equivalently “at least one of A and/or B”) may refer, in one embodiment, to at least one, optionally including more than one, A, with no B present (and optionally including entities other than B); in another embodiment, to at least one, optionally including more than one, B, with no A present (and optionally including entities other than A); in yet another embodiment, to at least one, optionally including more than one, A, and at least one, optionally including more than one, B (and optionally including other entities). In other words, the phrases “at least one,” “one or more,” and “and/or” are open-ended expressions that are both conjunctive and disjunctive in operation. For example, each of the expressions “at least one of A, B and C,” “at least one of A, B, or C,” “one or more of A, B, and C,” “one or more of A, B, or C” and “A, B, and/or C” may mean A alone, B alone, C alone, A and B together, A and C together, B and C together, A, B and C together, and optionally any of the above in combination with at least one other entity.

[0041] In the event that any patents, patent applications, or other references are incorporated by reference herein and (1) define a term in a manner that is inconsistent with and/or (2) are otherwise inconsistent with, either the non-incorporated portion of the present disclosure or any of the other incorporated references, the non-incorporated portion of the present disclosure shall control, and the term or incorporated disclosure therein shall only control with respect to the reference in which the term is defined and/or the incorporated disclosure was present originally.

[0042] As used herein the terms “adapted” and “configured” mean that the element, component, or other subject matter is designed and/or intended to perform a given function. Thus, the use of the terms “adapted” and “configured” should not be construed to mean that a given element, component, or other subject matter is simply “capable of” performing a given function but that the element, component, and/or other subject matter is specifically selected, created, implemented, utilized, programmed, and/or designed for the purpose of performing

the function. It is also within the scope of the present disclosure that elements, components, and/or other recited subject matter that is recited as being adapted to perform a particular function may additionally or alternatively be described as being configured to perform that function, and vice versa. Similarly, subject matter that is recited as being configured to perform a particular function may additionally or alternatively be described as being operative to perform that function.

[0043] As used herein, the terms “medial” and “medial side” refer to the inner side of a foot extending from the large toe to the heel, and the terms “lateral” and “lateral side” refer to the outer side of the foot extending from the small toe to the heel. Similarly, articles of footwear include medial and lateral sides that conform to the medial and lateral sides, respectively, of the foot. The term “centerline” refers to the major longitudinal axis along the length of an article of footwear, centered between the medial and lateral sides of the footwear article.

[0044] It is believed that the disclosure set forth above encompasses multiple distinct inventions with independent utility having applicability to the footwear industry. While each of these inventions has been disclosed in its preferred form, the specific embodiments thereof as disclosed and illustrated herein are not to be considered in a limiting sense as numerous variations are possible. The subject matter of the inventions includes all novel and non-obvious combinations and subcombinations of the various elements, features, functions and/or properties disclosed herein. Similarly, when the disclosure, the preceding numbered paragraphs, or subsequently filed claims recite “a” or “a first” element or the equivalent thereof, such claims should be understood to include incorporation of one or more such elements, neither requiring nor excluding two or more such elements.

[0045] Applicant reserves the right to submit claims directed to certain combinations and subcombinations that are directed to one of the disclosed inventions and are believed to be novel and non-obvious. Inventions embodied in other combinations and subcombinations of features, functions, elements and/or properties may be claimed through amendment of those claims or presentation of new claims in that or a related application. Such amended or new claims, whether they are directed to a different invention or directed to the same invention, whether different, broader, narrower or equal in scope to the original claims, are also regarded as included within the subject matter of the inventions of the present disclosure.

WHAT IS CLAIMED IS:

1. A boot, comprising:
an upper that defines a shaft and a shell and is configured to receive a wearer's foot;
an outsole that is operatively attached to the upper and configured to contact a ground surface when the wearer wears the boot; and
a spur stability system that includes at least one strap stability structure that is configured to resist motion of a spur strap relative to the boot when a spur is operatively attached to the boot with the spur strap.
2. The boot of claim 1, wherein the strap stability structure includes an upper strap stability structure that forms a portion of the upper.
3. The boot of claim 2, wherein the upper strap stability structure is configured to resist motion of an upper spur strap that, when present, extends across the upper in contact with the upper strap stability structure.
4. The boot of claim 2, wherein the upper strap stability structure extends from a surface of the upper to contact the upper spur strap.
5. The boot of claim 1, wherein the strap stability structure includes an upper strap stability structure that is operatively attached to the upper.
6. The boot of claim 1, wherein the strap stability structure includes a lower strap stability structure that forms a portion of the outsole.
7. The boot of claim 5, wherein the lower strap stability structure is configured to resist motion of a lower spur strap that, when present, extends across the outsole in contact with the lower strap stability structure.
8. The boot of claim 5, wherein the lower strap stability structure extends from a surface of the outsole to contact the lower spur strap.
9. The boot of claim 1, wherein the strap stability structure includes a lower strap stability structure that is operatively attached to the outsole.

10. The boot of claim 1, wherein the spur stability system further includes a spur rest that is configured to support a yoke of the spur.

11. The boot of claim 10, wherein the spur rest is located at least partially between the yoke and the outsole when the spur is operatively attached to the boot.

12. The boot of claim 10, wherein the spur rest is sized to resist motion toward the outsole by a portion of the yoke that is in contact with the spur seat.

13. The boot of claim 10, wherein the spur rest is defined by a protrusion that extends from a surface of the boot.

14. The boot of claim 1, wherein the boot further includes an abrasion-resistant toe region that is selected to resist damage to a toe region of the boot.

15. The boot of claim 14, wherein the abrasion-resistant toe region is formed from an abrasion-resistant material that is operatively attached to the upper.

16. The boot of claim 14, wherein the abrasion-resistant toe region is formed from a different material than at least a portion of a remainder of the upper.

17. The boot of claim 1, wherein the strap stability structure is defined by a stability structure material that is selected to have a high coefficient of static friction with the spur strap.

18. The boot of claim 17, wherein a coefficient of static friction between the stability structure material and the spur strap is at least a threshold multiple larger than a coefficient of static friction between a remainder of the upper and the spur strap, wherein the threshold multiple is at least 2 times larger than the coefficient of static friction between the remainder of the upper and the spur strap.

19. The boot of claim 17, wherein a coefficient of static friction between the stability structure material and the spur strap is at least a threshold multiple larger than a coefficient of static friction between a remainder of the upper and the spur strap, wherein the threshold multiple is at least 3 times larger than the coefficient of static friction between the remainder of the upper and the spur strap.

20. The boot of claim 17, wherein a coefficient of static friction between the stability structure material and the spur strap is at least a threshold multiple larger than a coefficient of static friction between a remainder of the upper and the spur strap, wherein the threshold multiple is at least 5 times larger than the coefficient of static friction between the remainder of the upper and the spur strap.

21. The boot of claim 17, wherein a coefficient of static friction between the stability structure material and the spur strap is at least a threshold multiple larger than a coefficient of static friction between a remainder of the upper and the spur strap, wherein the threshold multiple is at least 10 times larger than the coefficient of static friction between the remainder of the upper and the spur strap.

22. The boot of claim 1, wherein the strap stability structure is formed from at least one of a resilient material, a flexible material, an abrasion-resistant material, and a high-friction material.

23. The boot of claim 1, wherein the strap stability structure is formed from a material that grips the spur strap.

24. The boot of claim 1, wherein the strap stability structure is formed from a material that conforms to a surface of the spur strap.

25. The boot of claim 1, wherein the strap stability structure is formed from at least one of a polymeric material and an elastomeric material.

26. The boot of claim 1, wherein the strap stability structure defines a plurality of raised projections.

27. The boot of claim 1, wherein the strap stability structure defines a plurality of raised ribs.

28. The boot of claim 1, wherein the strap stability structure defines a plurality of raised ridges.

29. The boot of claim 1, wherein the strap stability structure is configured to be compressed between the spur strap and the boot.

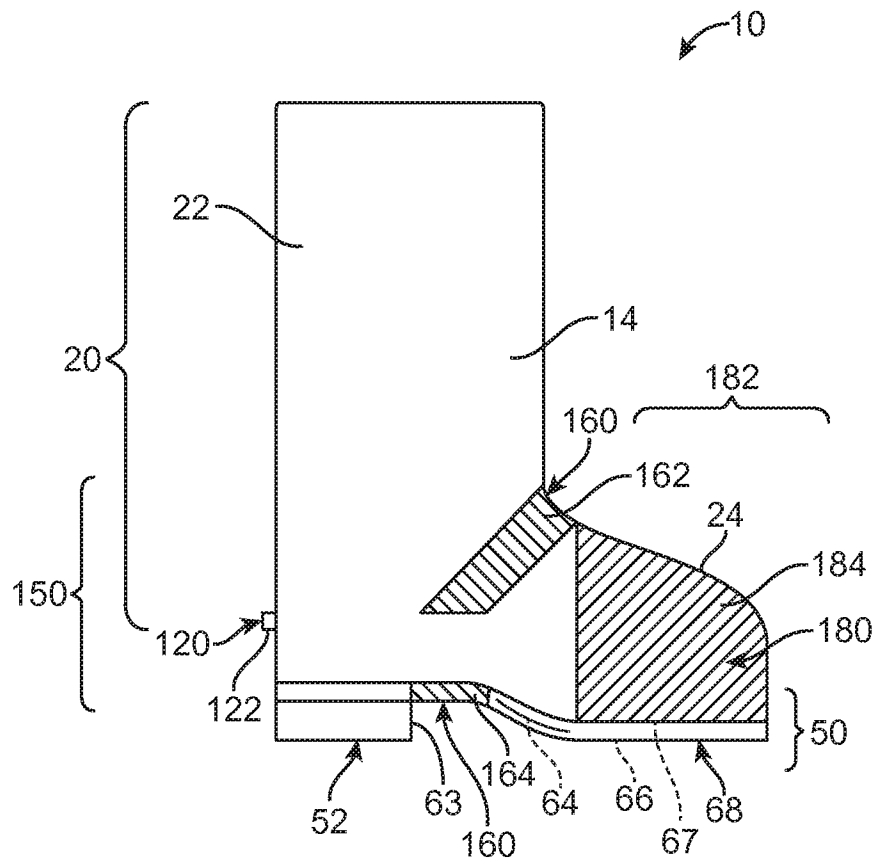

FIG. 1

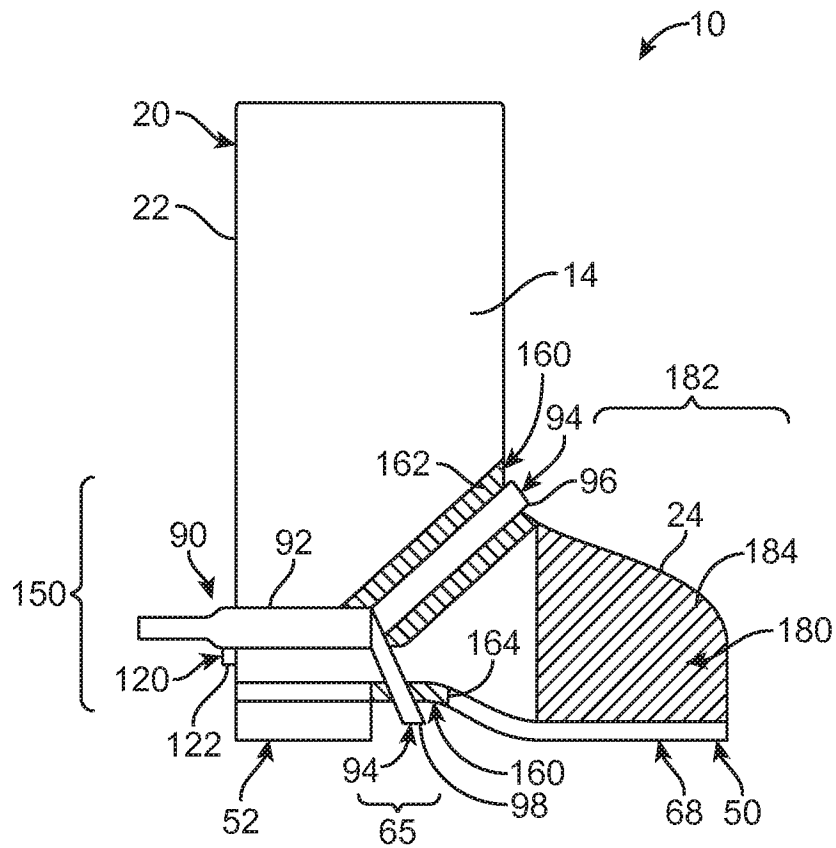

FIG. 2

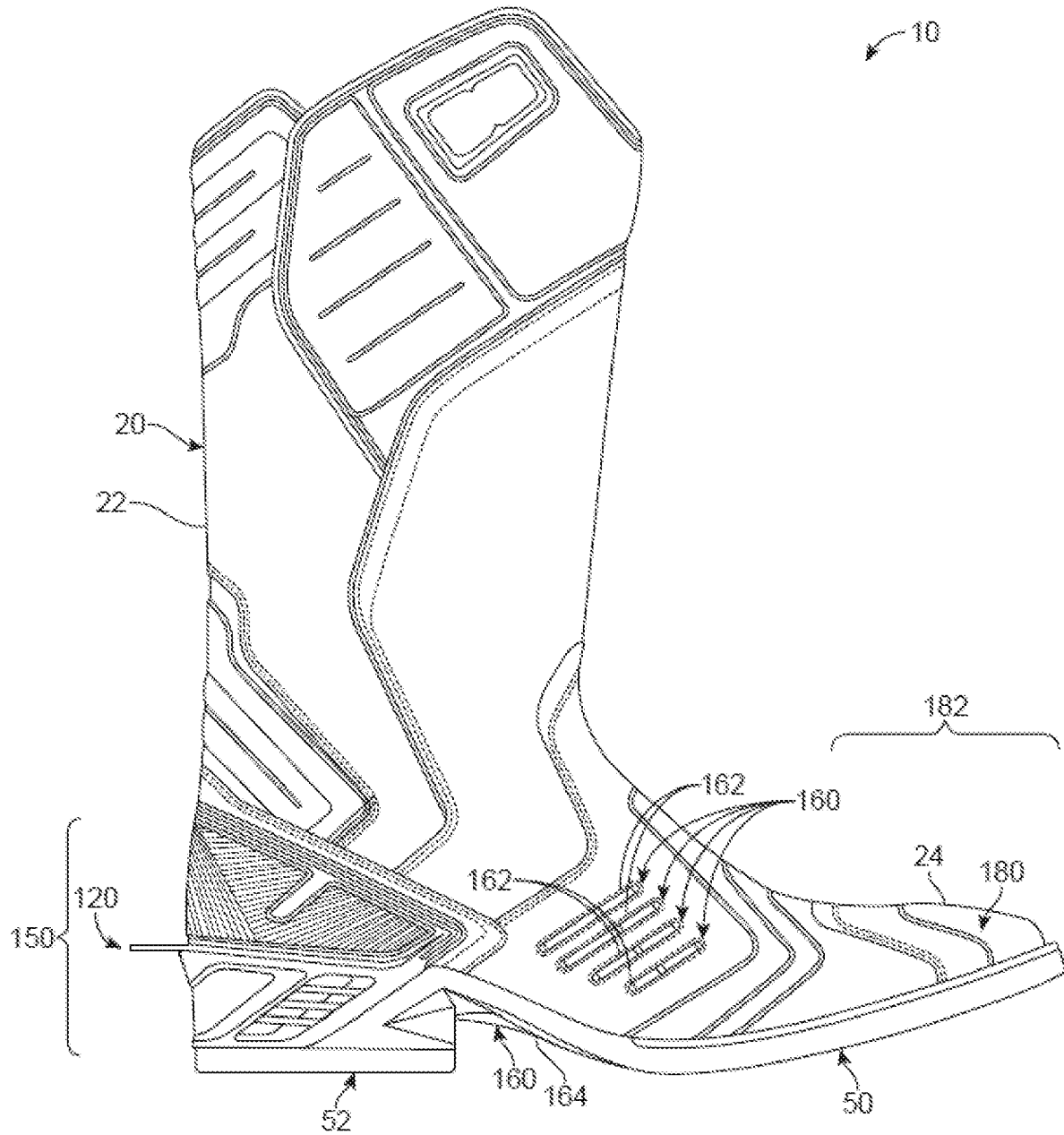

FIG. 4

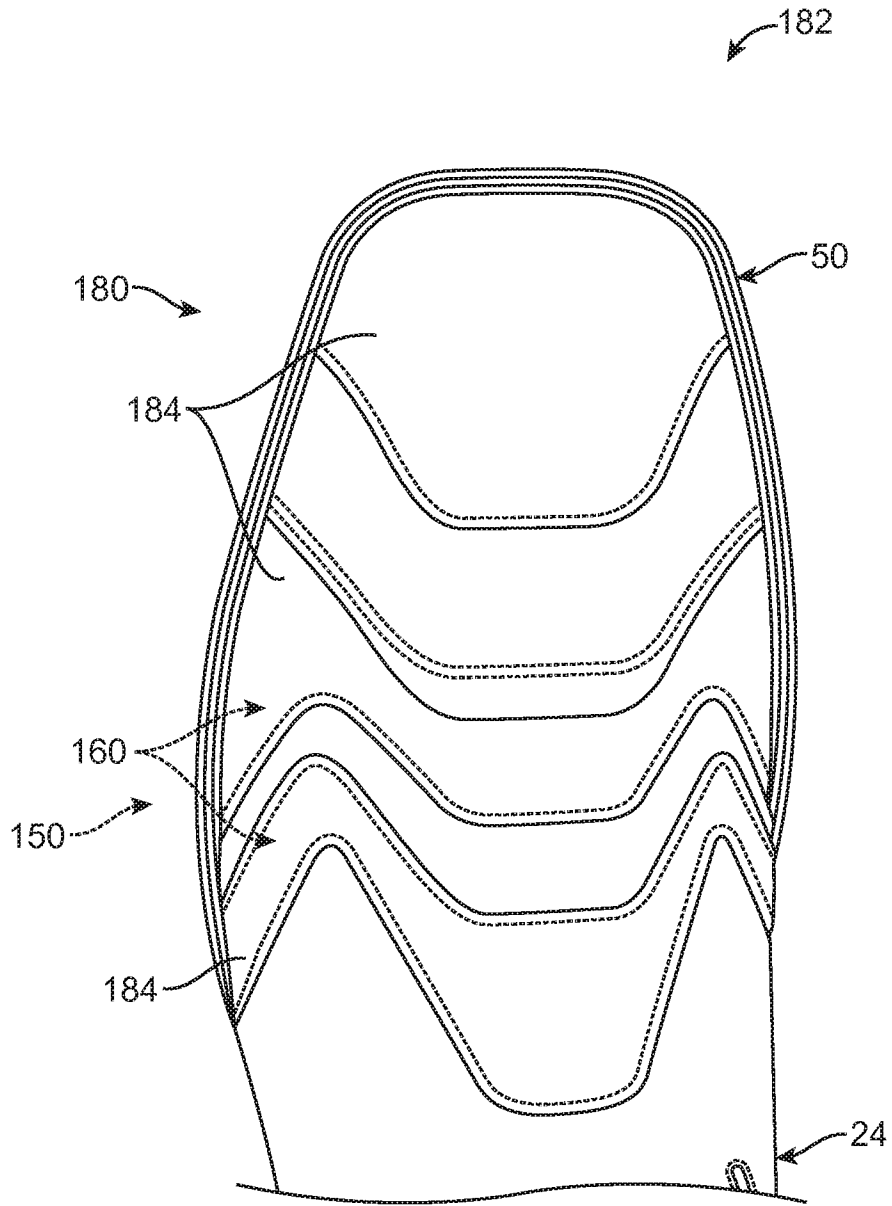

FIG. 5

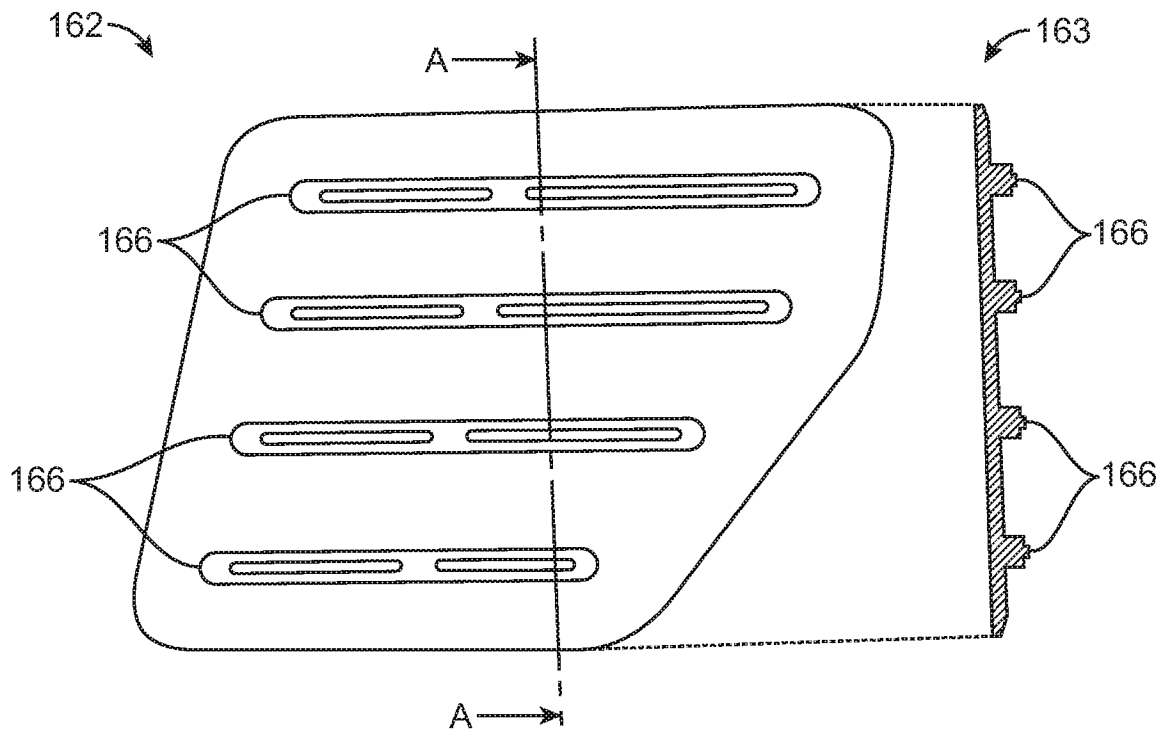

FIG. 6

7 / 7

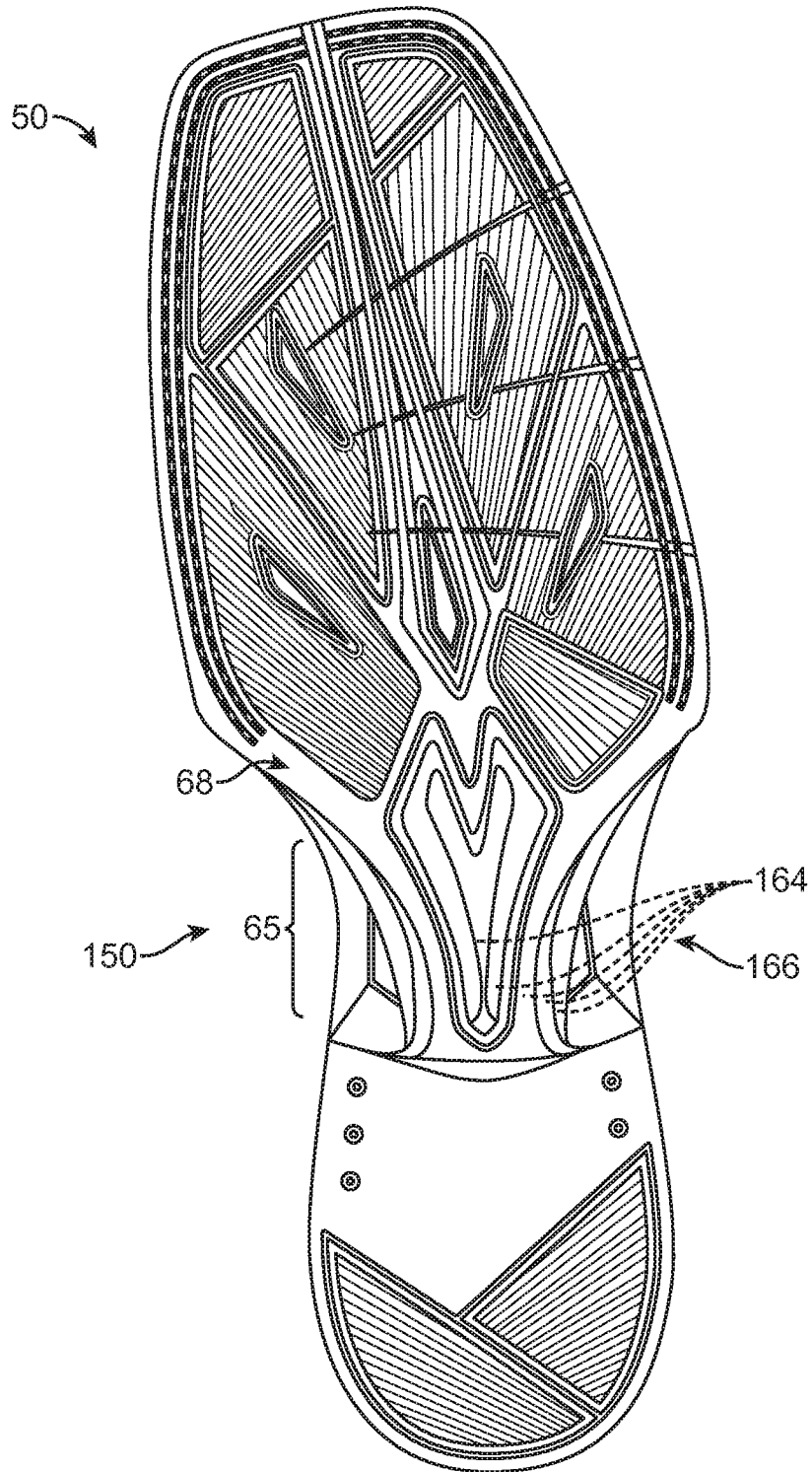

FIG. 7

INTERNATIONAL SEARCH REPORT

International application No.
PCT/US2014/038982

<p>A. CLASSIFICATION OF SUBJECT MATTER IPC(8) - A43C 17/00 (2014.01) CPC - A43C 17/00 (2014.07) According to International Patent Classification (IPC) or to both national classification and IPC</p>																																
<p>B. FIELDS SEARCHED</p> <p>Minimum documentation searched (classification system followed by classification symbols) IPC(8) - A43B 5/00, 5/14, 7/06, 7/08, 7/20, 11/00, 13/14, 23/02, 23/08; A43C 17/00, 17/04 (2014.01) CPC - A43B 3/0063, 5/006, 5/145, 7/08, 7/12, 11/00, 13/187, 21/26, 23/086, 23/16, 23/0235; A43C 17/00, 17/02, 17/04, 19/00 (2014.07)</p> <p>Documentation searched other than minimum documentation to the extent that such documents are included in the fields searched USPC - 36/31, 69, 74, 109, 114, 131, 136, 138; 54/83.1, 83.2</p> <p>Electronic data base consulted during the international search (name of data base and, where practicable, search terms used) Orbit, Google Patents, Google Scholar</p>																																
<p>C. DOCUMENTS CONSIDERED TO BE RELEVANT</p> <table border="1"> <thead> <tr> <th>Category*</th> <th>Citation of document, with indication, where appropriate, of the relevant passages</th> <th>Relevant to claim No.</th> </tr> </thead> <tbody> <tr> <td>X</td> <td>US 2011/0271553 A1 (MCCARRON) 10 November 2011 (10.11.2011) entire document</td> <td>1-9, 26-28</td> </tr> <tr> <td>...</td> <td></td> <td></td> </tr> <tr> <td>Y</td> <td></td> <td>10-17, 22-25, 29</td> </tr> <tr> <td>Y</td> <td>US 5,450,712 A (VAN SCOYK) 19 September 1995 (19.09.1995) entire document</td> <td>10-13</td> </tr> <tr> <td>Y</td> <td>US 2006/0042125 A1 (CHEN et al) 02 March 2006 (02.03.2006) entire document</td> <td>14-16</td> </tr> <tr> <td>Y</td> <td>US 7,866,065 B2 (MUNNS) 11 January 2011 (11.01.2011) entire document</td> <td>17, 22-25, 29</td> </tr> <tr> <td>A</td> <td>EP 2 319 345 A1 (MELE) 11 May 2011 (11.05.2011) entire document</td> <td>1-29</td> </tr> <tr> <td>A</td> <td>US 6,360,456 B2 (DAVIS et al) 26 March 2002 (26.03.2002) entire document</td> <td>1-29</td> </tr> <tr> <td>A</td> <td>US 2012/0266575 A1 (CHANG) 25 October 2012 (25.10.2012) entire document</td> <td>1-29</td> </tr> </tbody> </table>			Category*	Citation of document, with indication, where appropriate, of the relevant passages	Relevant to claim No.	X	US 2011/0271553 A1 (MCCARRON) 10 November 2011 (10.11.2011) entire document	1-9, 26-28	...			Y		10-17, 22-25, 29	Y	US 5,450,712 A (VAN SCOYK) 19 September 1995 (19.09.1995) entire document	10-13	Y	US 2006/0042125 A1 (CHEN et al) 02 March 2006 (02.03.2006) entire document	14-16	Y	US 7,866,065 B2 (MUNNS) 11 January 2011 (11.01.2011) entire document	17, 22-25, 29	A	EP 2 319 345 A1 (MELE) 11 May 2011 (11.05.2011) entire document	1-29	A	US 6,360,456 B2 (DAVIS et al) 26 March 2002 (26.03.2002) entire document	1-29	A	US 2012/0266575 A1 (CHANG) 25 October 2012 (25.10.2012) entire document	1-29
Category*	Citation of document, with indication, where appropriate, of the relevant passages	Relevant to claim No.																														
X	US 2011/0271553 A1 (MCCARRON) 10 November 2011 (10.11.2011) entire document	1-9, 26-28																														
...																																
Y		10-17, 22-25, 29																														
Y	US 5,450,712 A (VAN SCOYK) 19 September 1995 (19.09.1995) entire document	10-13																														
Y	US 2006/0042125 A1 (CHEN et al) 02 March 2006 (02.03.2006) entire document	14-16																														
Y	US 7,866,065 B2 (MUNNS) 11 January 2011 (11.01.2011) entire document	17, 22-25, 29																														
A	EP 2 319 345 A1 (MELE) 11 May 2011 (11.05.2011) entire document	1-29																														
A	US 6,360,456 B2 (DAVIS et al) 26 March 2002 (26.03.2002) entire document	1-29																														
A	US 2012/0266575 A1 (CHANG) 25 October 2012 (25.10.2012) entire document	1-29																														
<p><input type="checkbox"/> Further documents are listed in the continuation of Box C. <input type="checkbox"/></p>																																
<p>* Special categories of cited documents:</p> <table border="0"> <tr> <td style="vertical-align: top;"> <p>"A" document defining the general state of the art which is not considered to be of particular relevance</p> <p>"E" earlier application or patent but published on or after the international filing date</p> <p>"L" document which may throw doubts on priority claim(s) or which is cited to establish the publication date of another citation or other special reason (as specified)</p> <p>"O" document referring to an oral disclosure, use, exhibition or other means</p> <p>"P" document published prior to the international filing date but later than the priority date claimed</p> </td> <td style="vertical-align: top;"> <p>"T" later document published after the international filing date or priority date and not in conflict with the application but cited to understand the principle or theory underlying the invention</p> <p>"X" document of particular relevance; the claimed invention cannot be considered novel or cannot be considered to involve an inventive step when the document is taken alone</p> <p>"Y" document of particular relevance; the claimed invention cannot be considered to involve an inventive step when the document is combined with one or more other such documents, such combination being obvious to a person skilled in the art</p> <p>"&" document member of the same patent family</p> </td> </tr> </table>			<p>"A" document defining the general state of the art which is not considered to be of particular relevance</p> <p>"E" earlier application or patent but published on or after the international filing date</p> <p>"L" document which may throw doubts on priority claim(s) or which is cited to establish the publication date of another citation or other special reason (as specified)</p> <p>"O" document referring to an oral disclosure, use, exhibition or other means</p> <p>"P" document published prior to the international filing date but later than the priority date claimed</p>	<p>"T" later document published after the international filing date or priority date and not in conflict with the application but cited to understand the principle or theory underlying the invention</p> <p>"X" document of particular relevance; the claimed invention cannot be considered novel or cannot be considered to involve an inventive step when the document is taken alone</p> <p>"Y" document of particular relevance; the claimed invention cannot be considered to involve an inventive step when the document is combined with one or more other such documents, such combination being obvious to a person skilled in the art</p> <p>"&" document member of the same patent family</p>																												
<p>"A" document defining the general state of the art which is not considered to be of particular relevance</p> <p>"E" earlier application or patent but published on or after the international filing date</p> <p>"L" document which may throw doubts on priority claim(s) or which is cited to establish the publication date of another citation or other special reason (as specified)</p> <p>"O" document referring to an oral disclosure, use, exhibition or other means</p> <p>"P" document published prior to the international filing date but later than the priority date claimed</p>	<p>"T" later document published after the international filing date or priority date and not in conflict with the application but cited to understand the principle or theory underlying the invention</p> <p>"X" document of particular relevance; the claimed invention cannot be considered novel or cannot be considered to involve an inventive step when the document is taken alone</p> <p>"Y" document of particular relevance; the claimed invention cannot be considered to involve an inventive step when the document is combined with one or more other such documents, such combination being obvious to a person skilled in the art</p> <p>"&" document member of the same patent family</p>																															
<p>Date of the actual completion of the international search 07 September 2014</p>		<p>Date of mailing of the international search report 09 OCT 2014</p>																														
<p>Name and mailing address of the ISA/US Mail Stop PCT, Attn: ISA/US, Commissioner for Patents P.O. Box 1450, Alexandria, Virginia 22313-1450 Facsimile No. 571-273-3201</p>		<p>Authorized officer: Blaine R. Copenheaver PCT Helpdesk: 571-272-4300 PCT OSP: 571-272-7774</p>																														