

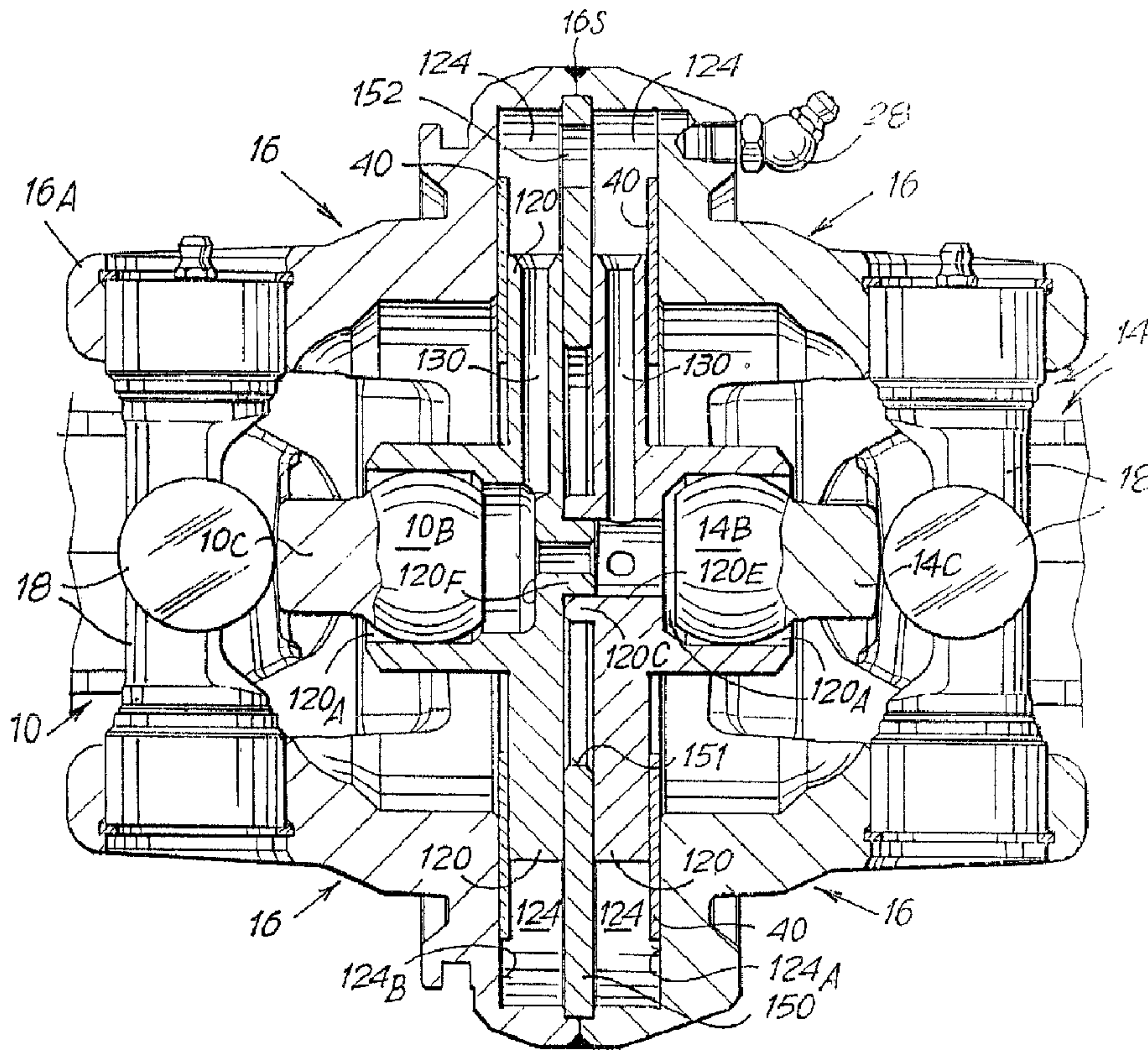

(22) Date de dépôt/Filing Date: 2003/12/31
 (41) Mise à la disp. pub./Open to Public Insp.: 2004/07/03
 (45) Date de délivrance/Issue Date: 2011/04/05
 (30) Priorité/Priority: 2003/01/03 (IT FI2003A000001)

(51) Cl.Int./Int.Cl. *F16D 3/30* (2006.01),
F16D 3/32 (2006.01)
 (72) Inventeur/Inventor:
BONDIOLI, EDI, IT
 (73) Propriétaire/Owner:
BONDIOLI, EDI, IT
 (74) Agent: FETHERSTONHAUGH & CO.

(54) Titre : JOINT HOMOCINETIQUE A GRAND ANGLE FABRIQUE DE FACON A REDUIRE LES CONTRAINTES DES ELEMENTS INTERNES
 (54) Title: WIDE-ANGLE CONSTANT-VELOCITY JOINT, WITH ARRANGEMENT FOR REDUCING THE STRESSES OF THE INTERNAL MEMBERS



(57) Abrégé/Abstract:

The joint comprises two spiders (10, 14) and a central core forming a cavity for sliding movement in a transverse plane for two constraint members (120) with seats (120A) for the spherical heads (10B; 14B) on the ends of the two forks (10, 14); a divider (150) divides said cavity into two housings (124) for the two constraint members (120).

WIDE-ANGLE CONSTANT-VELOCITY JOINT, WITH ARRANGEMENT
FOR REDUCING THE STRESSES OF THE INTERNAL MEMBERS

ABSTRACT

The joint comprises two spiders (10, 14) and a central core forming
5 a cavity for sliding movement in a transverse plane for two constraint
members (120) with seats (120A) for the spherical heads (10B; 14B) on the
ends of the two forks (10, 14); a divider (150) divides said cavity into two
housings (124) for the two constraint members (120).

10

(Fig. 5)

20333-545

1

"WIDE-ANGLE CONSTANT-VELOCITY JOINT, WITH ARRANGEMENT
FOR REDUCING THE STRESSES OF THE INTERNAL MEMBERS"

DESCRIPTION

The invention relates to a wide-angle constant-velocity joint for drive
5 shafts and the like, improved to give a reduction in the stresses to which
the internal members of conventional joints are usually subjected. These
and other objects and advantages will become clear in the course of the
following text.

The present wide-angle constant-velocity joint is of the type
10 comprising two forks forming the input and output members of the joint, two
spiders, and a central core forming a cavity for sliding movement in a
transverse plane for means forming constraint seats for the spherical
heads on the ends of the two forks.

According to an aspect of the invention, the joint comprises a divider which
15 divides said cavity into two housings for two substantially symmetrical
constraint members forming the respective seats for the spherical heads of
said forks; each of the two constraint members slides simultaneously with
the other member between said divider and the wall of the corresponding
one of the two parts of said central core or a laminar ring that bears against
20 said wall.

The two constraint members are joined together by two central
protrusions that slide one inside the other and the divider has a large
central window inside which said protrusions are able to move about.

Communication holes for lubrication of said seat are formed
25 between each housing and the seat of the constraint member housed in
said housing.

The two housings communicate through holes, to allow the supply of
lubricating grease from a single grease nipple.

20333-545

1a

According to another aspect of the invention, there is provided wide-angle constant-velocity joint comprising two forks forming the input and output members of the joint, two spiders, and a central core comprised of two parts and forming a cavity between two opposed walls, each formed by a corresponding one
5 of said two parts, for sliding movement in a transverse plane of two substantially symmetrical constraint members forming respective seats for spherical heads on the ends of said forks, the two constraint members being connected together, wherein a discoidal divider divides said cavity into two housings, each constraint member sliding between said discoidal divider and the corresponding one of said
10 opposed walls of said cavity or a laminar ring that bears against said wall.

A clearer understanding of the invention will be provided by the description and the attached drawing, the latter showing a practical, non-restrictive example of the invention. In the drawing:

Figs. 1 and 2 show a constant-velocity joint of an essentially
15 conventional kind, in longitudinal, section and in two positions which it is capable of assuming;

- 2 -

Figs. 3 and 4 show an improved constant-velocity joint according to the invention in longitudinal section and in two positions;

Fig. 5 shows a partial enlargement of Fig. 3;

5 Figs. 6 and 7 show in isolation one of two components constructed in accordance with the invention, in end view and in section on VII-VII as marked in Fig. 6; and

Fig. 8 is an exploded view in axial section of three internal components of a central core.

The accompanying drawing (Figs. 1 and 2) illustrates a wide-angle
10 constant-velocity joint of an essentially conventional kind. Reference 1 denotes a tubular component of a telescopic shaft ending in a wide-angle constant-velocity joint 5. The telescopic shaft 1 may be fitted with a protective sheath. The constant-velocity joint 5, of the wide-angle kind, comprises a power coupling member 9, for input to or output from the joint,
15 forming a grooved seat 9A for connection to a drive member with which the constant-velocity joint is combined. Integral with the member 9 is the base 10A of a fork 10 forming part of said joint 5. The telescopic shaft 1 is linked to a member 12 integral with the base 14A of a fork 14 forming part of said constant-velocity joint. Each of the two forks 10 and 14 comprises a
20 terminal crosspiece 10C, 14C, from which a spherical head 10B, 14B extends, the said two spherical heads being opposite each other. The constant-velocity joint also includes a central core 16 that is made in two parts which are basically symmetrical about a plane at right angles to the overall axis of the joint considered with the input and output components of
25 the members 9 and 12 in line with each other. The said two parts of the member 16 are connected together by welding at 16S, or by other means, such as bolts. The central core 16 has two opposing pairs of projections 16A, the projections of each pair forming seats of rotation for a corresponding spider, and each spider 18 is further hinged to the
30 corresponding fork 10, 14, respectively, described above.

The arrangement described above gives a typical constant-velocity joint, which is further completed by a constraint member 20 which is of a discoidal shape with a central circular cylindrical through seat 20A in which the opposing spherical heads 10B, 14B of the two forks 10 and 14 are

- 3 -

housed. The discoidal constraint member 20 is housed movably inside a discoidal housing 24, which is formed by two opposing parallel walls 24A, 24B formed by the two components of the central core 16. These two components are machined appropriately and then welded at 16S or otherwise connected together to retain the discoidal constraint member 20, 20B while allowing it to move. The central core 16 is provided with a grease nipple 28, which reaches the discoidal housing 24 via the discoidal constraint member 20. This member 20 has at least one radial hole 30 to allow communication between the housing 24 and the through seat 20A. This allows lubrication of the sliding surfaces 24A, 24B and the discoidal constraint member 20, and between the through seat 20A and the spherical heads 10B, 14B. Laminar rings 40 are usually interposed between the surfaces 24A and 24B and the two faces of the discoidal constraint member 20 to limit the losses of lubricating grease, which must first lubricate between the heads 10B or 14B and their seats.

So far an example of a shaft with a constant-velocity joint of known type has been described, of the type designed to transmit drive even at large angles, such as the angle X° shown in Fig. 2, the purpose of which is well known.

In conventional solutions, such as that defined above and illustrated in Figs. 1 and 2, fierce stresses are set out due to the simultaneous action of both spherical heads 10C, 14C rubbing against the discoidal constraint member 20 and against the seat 20A. This creates wrenching and wear, necessitating continual and efficient lubrication between parts in relative motion, and limits the total life of the joint.

This invention solves these problems. As illustrated in Fig. 3 and ff, where the same references in Figs. 1 and 2 are used for the corresponding parts, the single constraint member 20 is replaced with two substantially symmetrical separate constraint members 120, each having a seat 120A in which the corresponding spherical head 10B or 14B of the two forks 10 and 12, respectively, is slidingly accommodated. The central core 16 still consists of two substantially symmetrical parts, shaped to form a discoidal housing similar to the housing 24 of the embodiment shown in Figs. 1 and 2. When the two parts of the central core 16 are connected together (for

- 4 -

example by the weld 16S), a discoidal divider 150 (see also figs. 6, 7 and 8) with a large central circular window 151 is held peripherally between them. This divider 150 separates the abovementioned discoidal housing (similar to the housing 24) into two separate housings 124 communicating with each other through said window 151 and through a number of through holes 152. The grease nipple 28 therefore supplies both housings 124. Each of said two housings accommodates one of the two constraint members 120, which can slide in a guided manner between the corresponding surface of the divider 150 and the corresponding wall 124A or 124B or the corresponding laminar ring 40, if present. Each of said constraint members 120 has a number of radial holes 130 (for example three) which allow communication between the housing 124 and the corresponding seat 120A, to allow lubrication between the seat 120A and the corresponding head 10B or 14B. One of the two constraint members 120 (that on the right-hand side viewing the drawing) has a cylindrical protrusion 120C with a large through hole 120E into which the holes 130 lead. The other constraint member 120 has in turn a smaller cylindrical protrusion 120F designed to fit into the through hole 120E. When the components 120, 120 and 150 are brought together and the two parts of the core 16 welded at 16S, the protrusions 120C and 120F engage one inside the other in a sliding manner and can move about inside the window 152 of the divider 150 during the identical and simultaneous movements of the two constraint members 120 inside the housings 124. A through hole 120G in the protrusion 120F allows communication between the two seats 120A of the two constraint members 120.

As a result of the above arrangement, with the separation provided by the divider 150 and with the doubling up of the conventional constraint member 20 into two constraint members 120 constrained by each other in only a limited degree by the protrusions 120C and 120F, there is a reduction in the stresses which are otherwise very high between the members of the joints, especially those in relative sliding movement and in particular between the heads 10B, 14B and the corresponding seats 120A, which now belong to two separate components. The resulting joint has a much longer life than conventional constant-velocity joints.

- 5 -

It will be understood that the drawing shows only an example given purely as a practical demonstration of the invention, which latter may be varied in its shapes and arrangements without thereby departing from the scope of the concept on which the invention is based. The presence of any
5 reference numbers in the appended claims is purely for the purpose of facilitating the reading of the claims with reference to the description and drawing, and does not limit the scope of protection represented by the claims.

20333-545

6

CLAIMS:

1. Wide-angle constant-velocity joint comprising two forks forming the input and output members of the joint, two spiders, and a central core comprised of two parts and forming a cavity between two opposed walls, each formed by a
5 corresponding one of said two parts, for sliding movement in a transverse plane of two substantially symmetrical constraint members forming respective seats for spherical heads on the ends of said forks, the two constraint members being connected together, wherein a discoidal divider divides said cavity into two housings, each constraint member sliding between said discoidal divider and the
10 corresponding one of said opposed walls of said cavity or a laminar ring that bears against said wall.
2. Constant-velocity joint according to claim 1, wherein the two constraint members are joined together by two central protrusions that slide one inside the other, and wherein the discoidal divider has a central window inside
15 which said protrusions are able to move about.
3. Constant-velocity joint according to claim 1, wherein each of said constraint members has a discoidal shaped portion sliding in a guided manner between the corresponding surface of said discoidal divider and the respective one of said walls or the corresponding laminar ring.
- 20 4. Constant-velocity joint according to claim 2, wherein each of said constraint members has a discoidal shaped portion sliding in a guided manner between the corresponding surface of said discoidal divider and the respective one of said walls or the corresponding laminar ring.
5. Constant-velocity joint according to claim 4, wherein the central
25 protrusion of each constraint member is arranged centrally with respect to the corresponding discoidal shaped portion.
6. Constant-velocity joint according to any one of claims 1 to 5, wherein said discoidal divider is rigidly connected to said central core.

20333-545

7

7. Constant-velocity joint according to any one of claims 1 to 6, wherein said discoidal divider is held peripherally between said two parts forming the central core, when said two parts are connected together.

8. Constant-velocity joint according to any one of claims 1 to 7, wherein
5 communication holes for lubrication of said seats are formed between each housing and the seat of the constraint member housed in said housing.

9. Constant-velocity joint according to any one of claims 1 to 8, wherein the two housings communicate through holes in said discoidal divider, to allow the supply of lubricating grease from a single grease nipple.

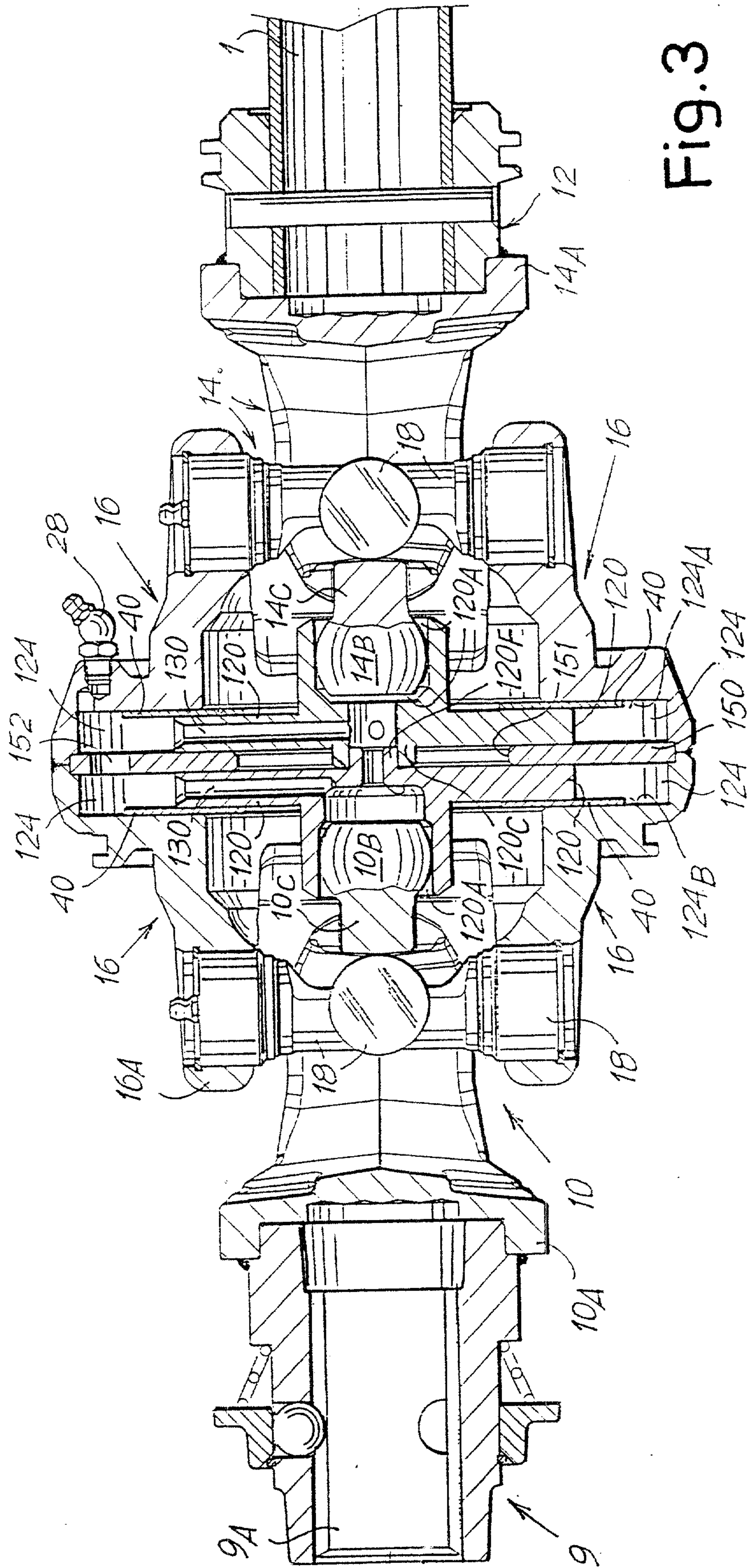

Fig. 3

4 / 7

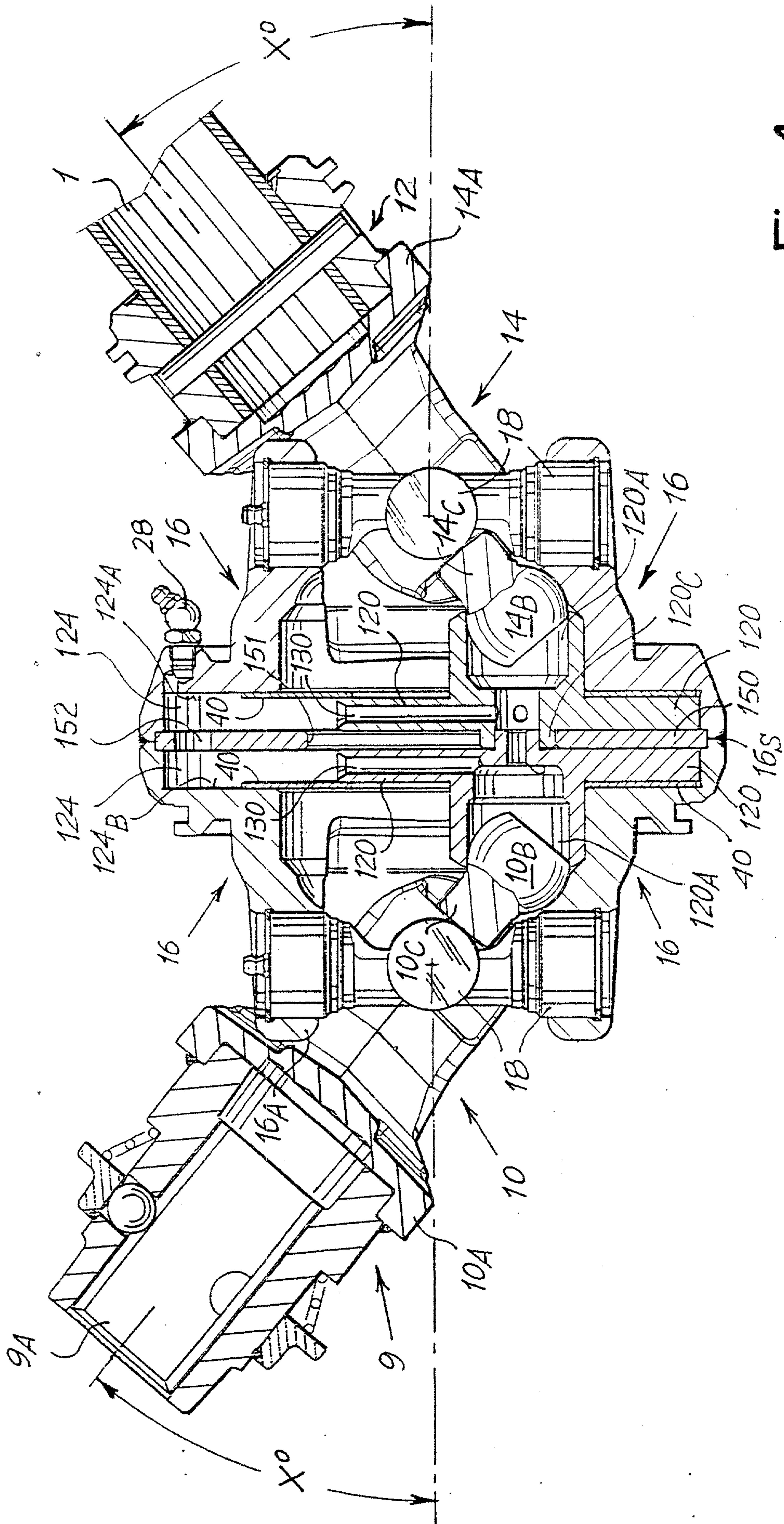

Fig. 4

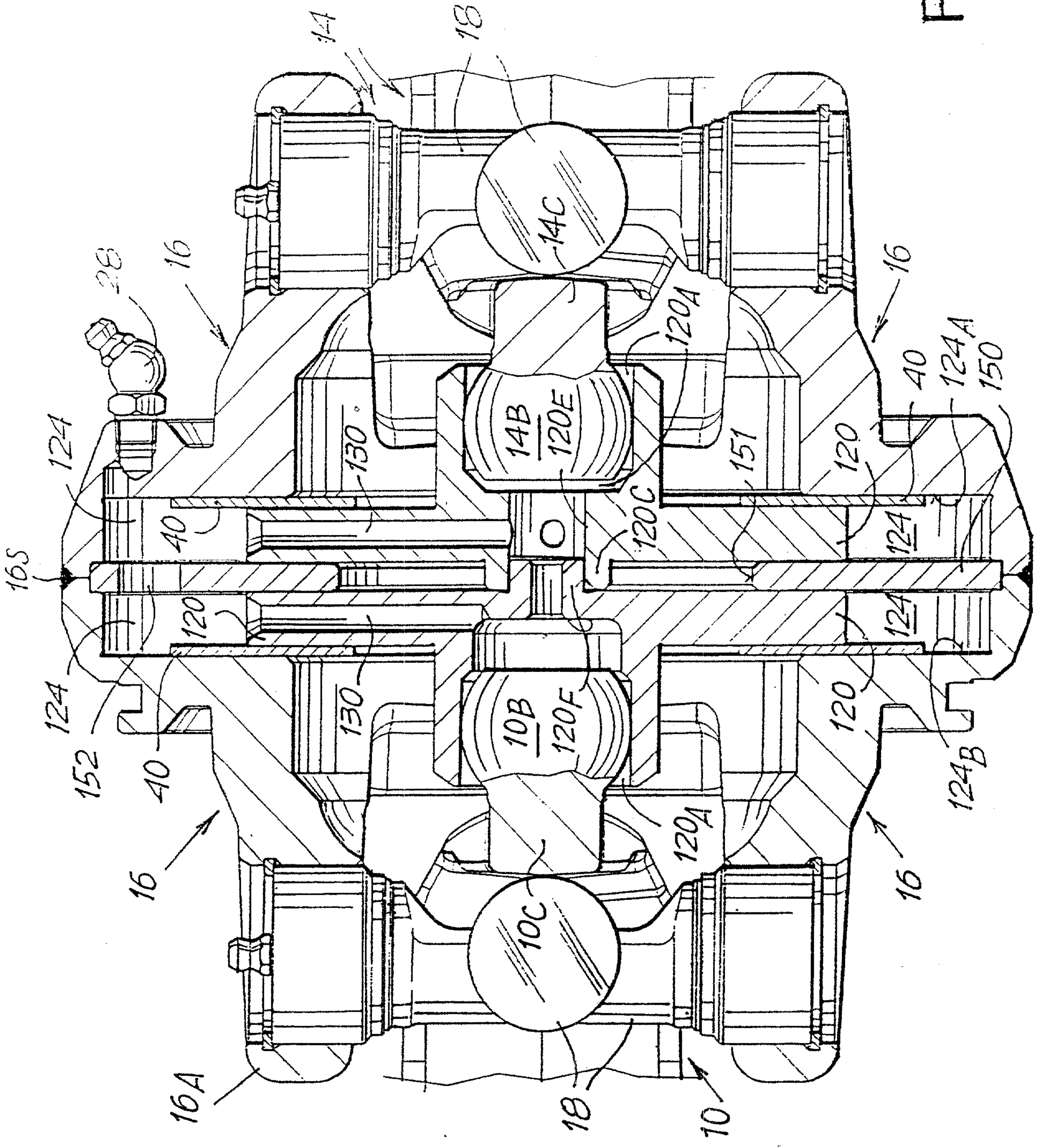

Fig. 5

6 / 7

Fig 6

Fig.7

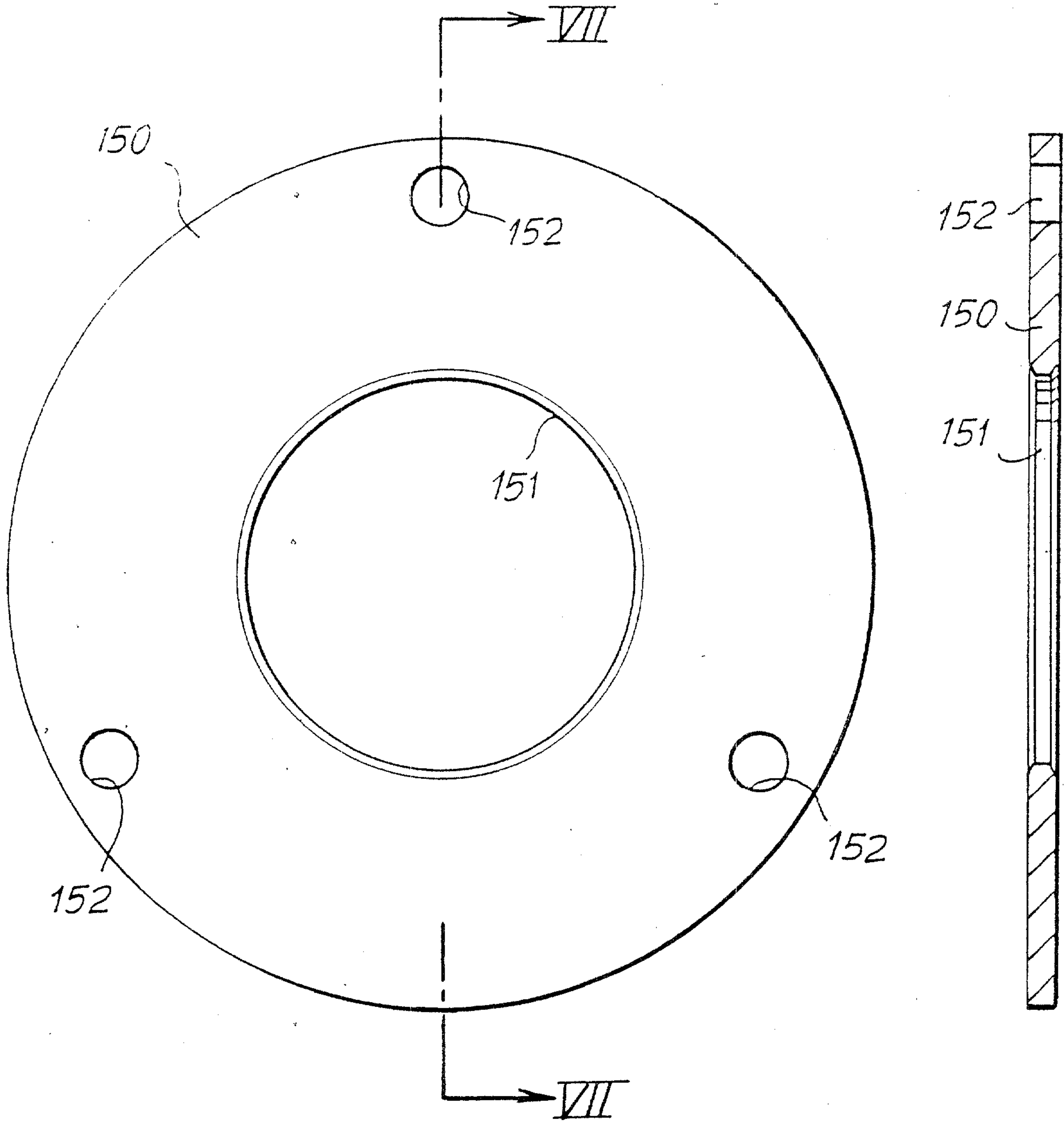

Fig. 8

