

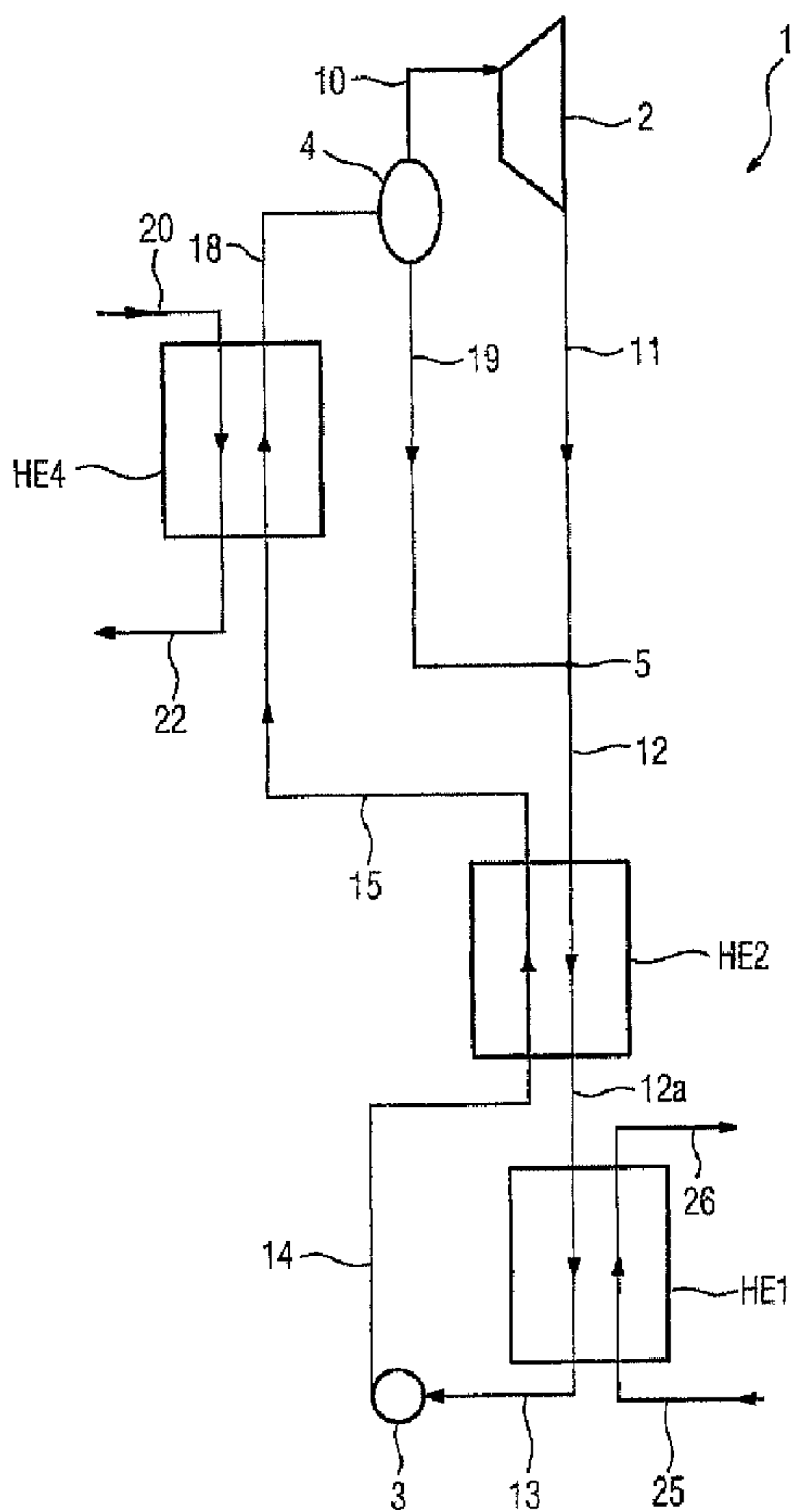

(86) Date de dépôt PCT/PCT Filing Date: 2005/04/13
 (87) Date publication PCT/PCT Publication Date: 2005/10/27
 (45) Date de délivrance/Issue Date: 2010/03/23
 (85) Entrée phase nationale/National Entry: 2006/10/13
 (86) N° demande PCT/PCT Application No.: EP 2005/051617
 (87) N° publication PCT/PCT Publication No.: 2005/100755
 (30) Priorité/Priority: 2004/04/16 (DE10 2004 018 627.8)

(51) Cl.Int./Int.Cl. *F01K 25/06* (2006.01)
 (72) Inventeur/Inventor:
 LENGERT, JOERG, DE
 (73) Propriétaire/Owner:
 SIEMENS AKTIENGESELLSCHAFT, DE
 (74) Agent: FETHERSTONHAUGH & CO.

(54) Titre : METHODE ET DISPOSITIF POUR EXECUTER UN PROCEDE A CYCLE THERMODYNAMIQUE
 (54) Title: METHOD AND DEVICE FOR EXECUTING A THERMODYNAMIC CYCLE PROCESS



(57) Abrégé/Abstract:

The aim of the invention is to reduce the complexity of a cyclic process. To this end, the pressure of a liquid working substance flow (13) is increased and a first partially evaporated working substance flow (15) is produced by the partial condensation of a working

(57) Abrégé(suite)/Abstract(continued):

substance flow (12) with a low surface tension. Further evaporation of the first partially evaporated working substance flow (15) with heat transmitted by an external heat source (20) produces a second at least partially evaporated working substance flow (18). In said second at least partially evaporated working substance flow (18), the vaporous phase (10) is separated from the liquid phase, the energy of the vaporous phase (10) is converted into a usable form, and a vaporous phase (11) with a low surface tension is combined with the liquid phase (19) in such a way as to form the working substance flow (12) with a low surface tension. The liquid working substance flow (13) is, in turn, obtained by complete condensation of the partially condensed working substance flow (12a) with a low surface tension.

(12) NACH DEM VERTRAG ÜBER DIE INTERNATIONALE ZUSAMMENARBEIT AUF DEM GEBIET DES PATENTWESENS (PCT) VERÖFFENTLICHTE INTERNATIONALE ANMELDUNG

(19) Weltorganisation für geistiges Eigentum
Internationales Büro(43) Internationales Veröffentlichungsdatum
27. Oktober 2005 (27.10.2005)

PCT

(10) Internationale Veröffentlichungsnummer
WO 2005/100755 A1(51) Internationale Patentklassifikation⁷: F01K 25/06

(72) Erfinder; und

(21) Internationales Aktenzeichen: PCT/EP2005/051617

(75) Erfinder/Anmelder (nur für US): LENGERT, Jörg
[DE/DE]; Schwalbenstr. 6, 91475 Lonnerstadt (DE).(22) Internationales Anmeldedatum:
13. April 2005 (13.04.2005)

(74) Gemeinsamer Vertreter: SIEMENS AKTIENGESELLSCHAFT; Postfach 22 16 34, 80506 München (DE).

(25) Einreichungssprache: Deutsch

(26) Veröffentlichungssprache: Deutsch

(30) Angaben zur Priorität:
10 2004 018 627.8 16. April 2004 (16.04.2004) DE

(71) Anmelder (für alle Bestimmungsstaaten mit Ausnahme von US): SIEMENS AKTIENGESELLSCHAFT [DE/DE]; Wittelsbacherplatz 2, 80333 München (DE).

(81) Bestimmungsstaaten (soweit nicht anders angegeben, für jede verfügbare nationale Schutzrechtsart): AE, AG, AL, AM, AT, AU, AZ, BA, BB, BG, BR, BW, BY, BZ, CA, CH, CN, CO, CR, CU, CZ, DE, DK, DM, DZ, EC, EE, EG, ES, FI, GB, GD, GE, GH, GM, HR, HU, ID, IL, IN, IS, JP, KE, KG, KM, KP, KR, KZ, LC, LK, LR, LS, LT, LU, LV, MA, MD, MG, MK, MN, MW, MX, MZ, NA, NI, NO, NZ, OM, PG, PH, PL, PT, RO, RU, SC, SD, SE, SG, SK, SL, SM, SY,

[Fortsetzung auf der nächsten Seite]

(54) Title: METHOD AND DEVICE FOR CARRYING OUT A THERMODYNAMIC CYCLIC PROCESS

(54) Bezeichnung: VERFAHREN UND VORRICHTUNG ZUR AUSFÜHRUNG EINES THERMODYNAMISCHEN KREISPROZESSES

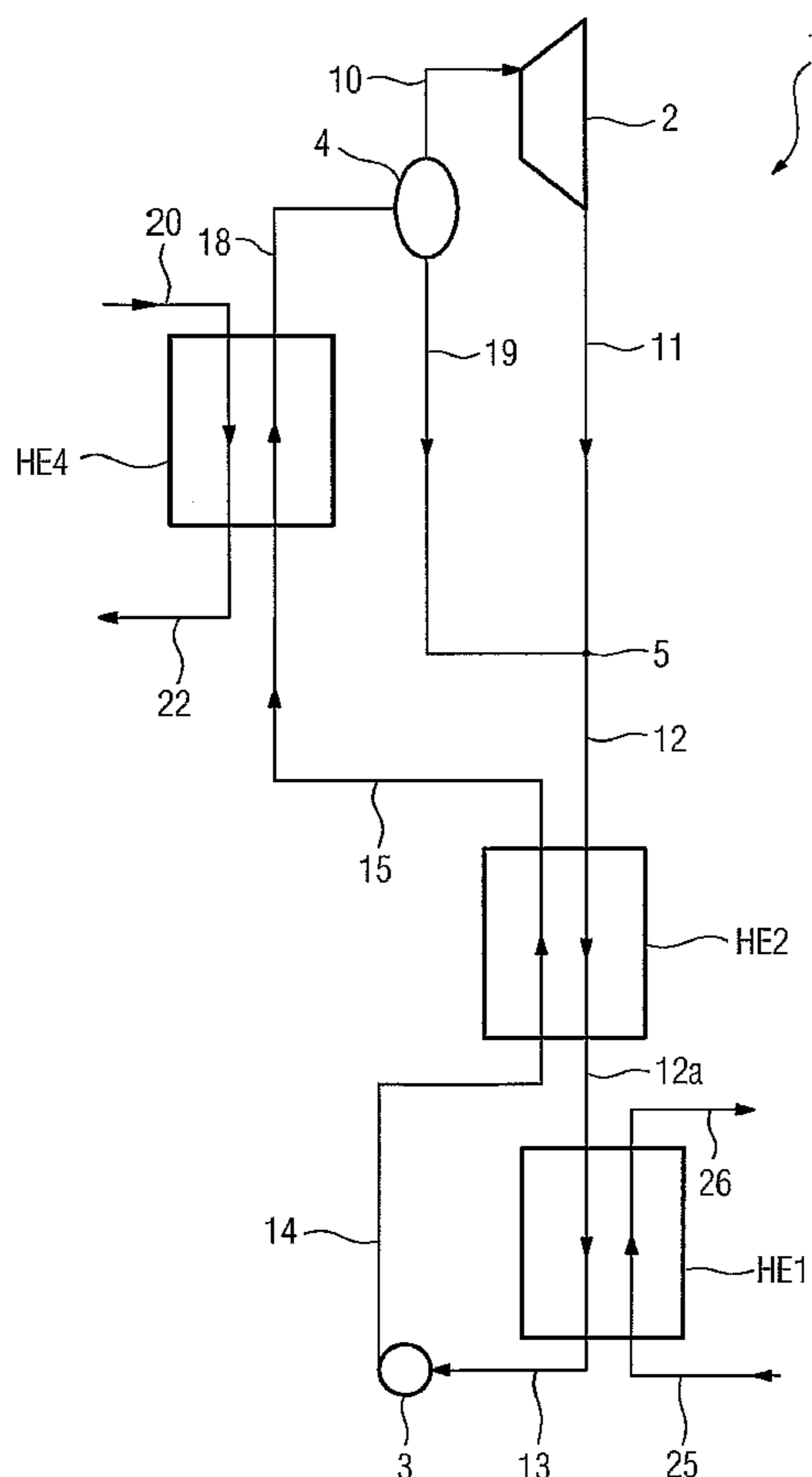

(57) Abstract: The aim of the invention is to reduce the complexity of a cyclic process. To this end, the pressure of a liquid working substance flow (13) is increased and a first partially evaporated working substance flow (15) is produced by the partial condensation of a working substance flow (12) with a low surface tension. Further evaporation of the first partially evaporated working substance flow (15) with heat transmitted by an external heat source (20) produces a second at least partially evaporated working substance flow (18). In said second at least partially evaporated working substance flow (18), the vaporous phase (10) is separated from the liquid phase, the energy of the vaporous phase (10) is converted into a usable form, and a vaporous phase (11) with a low surface tension is combined with the liquid phase (19) in such a way as to form the working substance flow (12) with a low surface tension. The liquid working substance flow (13) is, in turn, obtained by complete condensation of the partially condensed working substance flow (12a) with a low surface tension.

(57) Zusammenfassung: Gemäß der Erfindung wird zur Reduzierung der Komplexität eines Kreisprozesses ein flüssiger Arbeitsmittelstrom (13) auf einen erhöhten Druck gebracht und durch Teilkondensation eines entspannten Arbeitsmittelstroms (12) ein erster teilweise verdampfter Arbeitsmittelstrom (15) erzeugt. Durch weiteres Verdampfen des ersten teilweise verdampften Arbeitsmittelstroms (15) mit Wärme, die von einer externen Wärmequelle (20) übertragen wird, wird ein zweiter zumindest teilweise verdampfter Arbeitsmittelstrom (18) erzeugt. Bei diesem zweiten zumindest teilweise verdampften Arbeitsmittelstroms (18) wird die dampfförmige Phase (10) von der flüssigen Phase getrennt, anschließend die Energie der dampfförmigen Phase (10) in eine nutzbare Form umgewandelt und eine entspannte dampfförmige Phase (11) wird mit der flüssigen Phase (19) zusammengeführt und der entspannte Arbeitsmittelstrom (12) gebildet. Durch vollständige Kondensation des teilkondensierten, entspannten Arbeitsmittelstroms (12a) wird wiederum der flüssige Arbeitsmittelstrom (13) gewonnen.

WO 2005/100755 A1

WO 2005/100755 A1

TJ, TM, TN, TR, TT, TZ, UA, UG, US, UZ, VC, VN, YU,
ZA, ZM, ZW.

PL, PT, RO, SE, SI, SK, TR), OAPI (BF, BJ, CF, CG, CI,
CM, GA, GN, GQ, GW, ML, MR, NE, SN, TD, TG).

(84) Bestimmungsstaaten (*soweit nicht anders angegeben, für jede verfügbare regionale Schutzrechtsart*): ARIPO (BW, GH, GM, KE, LS, MW, MZ, NA, SD, SL, SZ, TZ, UG, ZM, ZW), eurasisches (AM, AZ, BY, KG, KZ, MD, RU, TJ, TM), europäisches (AT, BE, BG, CH, CY, CZ, DE, DK, EE, ES, FI, FR, GB, GR, HU, IE, IS, IT, LT, LU, MC, NL,

Veröffentlicht:

— *mit internationalem Recherchenbericht*

Zur Erklärung der Zweibuchstaben-Codes und der anderen Abkürzungen wird auf die Erklärungen ("Guidance Notes on Codes and Abbreviations") am Anfang jeder regulären Ausgabe der PCT-Gazette verwiesen.

20365-5058

- 1 -

Description

Method and device for executing a thermodynamic cycle process

The invention relates to a method and a device for executing a thermodynamic cycle process.

Thermal power stations use thermodynamic cycle processes for converting heat into mechanical or electrical energy. Conventional thermal power stations create the heat by burning fuel, in particular the fossil fuels coal, oil and gas. The cycle processes are operated in this case for example on the basis of the classic Rankine cycle process with water as its working medium. Its high boiling point however makes water unattractive, especially when using heat sources with temperatures between 100° to 200°C, e.g. geothermal liquids or waste heat from combustion processes, because the process is not cost effective.

For heat sources with such a low temperature a wide diversity of technologies have been developed over recent years which make it possible to convert their heat into mechanical or electrical energy with a high degree of efficiency. As well as the Rankine process with organic working media (Organic Rankine Cycle, ORC) a process known as the Kalina cycle process stands out above all by virtue of its markedly better levels of efficiency compared to the classic Rankine process. Various cycles for different applications have been developed on the basis of the Kalina cycle process. Instead of water these cycles use a mixture of two substances (e.g. ammonia and water) as their working medium, with the non-isothermic boiling and condensation process of the mixture being utilized to increase the efficiency of the cycle by comparison with the Rankine cycle.

2004P03875 WO (amended sheet for the transition, not for US and WE)

2

For temperatures of the heat source of 100 to 140°C the Kalina cycle KCS 34 (Kalina Cycle System 34) is preferably used, which is employed for example in the geothermal power plant at Husavik in Iceland (see also EP 1 070 830 A1). In this cycle (see also FIG 3) a liquid working medium is pumped into a first heat exchanger where it is heated up by a part condensation of an expanded working medium flow. The heated working medium flow produced in this way is then further heated up by cooling the liquid phase of a partly vaporized working medium flow in a second heat exchanger and subsequently partly vaporized (e.g. to a liquid content of 14 - 18%) in a third heat exchanger using heat transmitted from an external heat source (e.g. a geothermal liquid). Then the liquid phase of the partly vaporized working medium flow is separated from the vapor phase in a separator.

The vapor phase is expanded in a turbine and its energy is used for generating power. The liquid phase is directed through the second heat exchanger and used for further heating of the heated working medium flow. In a mixer the liquid phase and the expanded vapor phase are merged and the expanded working medium flow already mentioned is formed. The expanded working medium flow is subsequently partly condensed in the first heat exchanger and finally fully condensed in a condenser so that the liquid working medium flow mentioned at the start is created and the cycle is completed.

Using this known cycle process as its starting point, the object of the present invention is to specify a method and a device for executing a thermodynamic cycle process, which, with the same external heat source and cooling water temperature, and with plant costs which essentially remain the same, makes it possible to produce the same or even a higher yield of mechanical

20365-5058

- 3 -

and/or electrical energy, but with the method and the device standing out however by virtue of their lower complexity.

In accordance with one aspect of the invention, there is provided a method for executing a thermodynamic cycle process with at least the following steps: pumping a flow of liquid working medium at an increased pressure and forming a pressurized, liquid working medium flow; heating up and part vaporization of the pressurized, liquid working medium flow by part condensation of an expanded working medium flow and creation of a first partly vaporized working medium flow and of a partly condensed, expanded working medium flow; further vaporization of the partly vaporized working medium flow with heat which is transferred from an external heat source, and creation of a second at least partly vaporized working medium flow; separation of a liquid phase from a vapor phase of the second at least partly vaporized working medium flow; expansion of the vapor phase conversion of its energy into a usable form and creation of an expanded vapor phase; mixing of the liquid phase with the expanded vapor phase and formation of the expanded working medium flow; complete condensation of the partly condensed, expanded working medium flow and creation of the liquid working medium flow.

Advantageous embodiments of the method are described herein.

In another aspect of the invention, there is provided a device for executing a thermodynamic cycle process, especially for executing the method described herein, with at least a pump for pumping a flow of liquid working medium at an increased pressure and creating a pressurized liquid working medium flow; a first heat exchanger for creating a first partly vaporized working medium flow by heating up and part vaporization of the pressurized liquid working medium flow through part

20365-5058

- 3a -

condensation of an expanded working medium flow; a second heat exchanger for creating a second at least partly vaporized working medium flow through further vaporization of the first partly vaporized working medium flow with heat
5 which is transferred from an external heat source; a separator for separation of a liquid phase from a vapor phase of the second at least partly vaporized working medium flow; a device, especially a turbine, for expanding the vapor phase, converting its energy into a usable form and
10 creating an expanded vapor phase; a mixer for mixing the liquid phase with the expanded vapor phase and creating an expanded working medium flow; a third heat exchanger for completely condensing the partly condensed, expanded working medium flow and creating the liquid working medium flow.

15 Advantageous embodiments of the device are described herein.

In accordance with the invention, by part condensation of the expanded flow of working medium the pressurized liquid flow of working medium is not only heated up but even partly vaporized. This is possible because, by comparison with the
20 KCS 34 cycle mentioned at the start, the second heat exchanger and thereby the transmission of heat from the liquid phase of the partly vaporized working medium flow for further heating or for part vaporization of the heated working medium flow is dispensed with. This removes less
25 heat in the liquid phase which is subsequently used for better heating and partial vaporization of the pressurized liquid working medium flow by part condensation of the expanded working medium flow.

By suitably adapting the heating surfaces of the remaining
30 heat exchangers and other cycle parameters it is possible not only to keep the yield of mechanical and/or electrical energy the same by comparison with the known cycle but even

20365-5058

- 3b -

to increase it. The costs of a possibly increased heating surface requirement in the remaining heat exchangers could in this case be largely compensated for by the omission of the second heat exchanger and the associated simplification of the pipework, thus keeping the plant costs essentially the same.

PCT/EP2005/051617
2004P03875WOAU

- 4 -

By dispensing with the second heat exchanger mentioned at the start or dispensing with a heat transfer from the liquid phase to the first partly vaporized working medium flow, the device and the method in accordance with the invention stand out because of they are less complex by comparison with the prior art.

The part vaporization of the pressurized, liquid working medium flow by part condensation of the expanded working medium flow can be favorably improved by the pressure of the vapor phase amounting to less than 24 bar and thereby being far less than the 33 bar figure known from previous cycles. In this way the overall pressure level in the cycle can be reduced, which enables the boiling temperature of the working medium in its turn to be reduced.

When the pressure of the vapor phase before entry into the turbine is three times as great as the pressure of the expanded vapor phase it is also possible to use conventional single-stage expander turbines. These types of expander turbines have levels of efficiency of up to 88% and thereby far greater levels of efficiency than the multi-stage expander turbines previously used in these types of cycles, e.g. designed for a maximum pressure of 33 bar with levels of efficiency of appr. 75%. A loss in the degree of efficiency possibly associated with a reduction in the pressure level or the lower pressure ratio over the expander turbine in the cycle is there by more than compensated for by the better efficiency of the turbine and the greater possible throughput of working medium which allows comparably more energy to be extracted from the thermal water.

When a conventional single-stage expander turbine is used, the costs of a second turbine stage or the additional costs for a specific turbine design for high differences in pressure are also not incurred.

PCT/EP2005/051617
2004P03875WOAU

- 5 -

In accordance with an embodiment of the invention a multi-substance mixture is used as the working medium. The multi-substance mixture is preferably a two-substance mixture, especially an ammonia-water mixture. As a result of the non-isothermic vaporization and condensation of such a mixture an especially high level of efficiency of the cycle can be achieved.

Energy can be obtained in an especially environmentally friendly way by using a geothermal liquid, especially thermal water, from a geothermal source, as the heat source. Waste gases (exhaust gases) from gas and/or steam turbine plants can however also be used as the heat source or heat generated in industrial production processes (e.g. in steel production) can be used.

A high level of efficiency of the cycle can in this case be achieved by the heat source having a temperature of 100°C to 200°C, especially 100°C to 140°C.

The invention as well as further advantageous embodiments of the invention in accordance with the features of the subclaims are explained in more detail below with reference to exemplary embodiments in the figures. The figures show:

- FIG 1 a circuit of an inventive device for executing a thermodynamic cycle process in a simplified schematic presentation,
- FIG 2 a cycle calculation for a device in accordance with Figure 1,
- FIG 3 a circuit for a device known from the prior art for executing a thermodynamic cycle process in a simplified, schematic presentation,
- FIG 4 a cycle calculation for a device in accordance with Figure 3.

PCT/EP2005/051617
2004P03875WOAU

- 6 -

The device 1 shown in Figure 1 for executing a thermodynamic cycle process features a (recuperative) heat exchanger HE4, which on the primary side has hot thermal water 20 from a geothermal source not shown in any greater detail flowing through it and is connected on the secondary side on the one hand to a heat exchanger HE2 and on the other hand to a separator 4. The separator 4 is used for separating a vapor phase from a liquid phase of a partly vaporized working medium. A vapor-side output of the separator 4 is connected to a turbine 2. The turbine 2 is connected on its output side to a mixer 5 which is still connected with a liquid input of the separator 4. On the output side the mixer 5 is connected to the secondary side of a (recuperative) heat exchanger HE2 which in its turn is connected to the primary side of a condenser HE1 through which cooling water flows on the secondary side. The condenser HE1 is connected at its primary-side output, if necessary via a condensing tank, via a pump 3 to the primary side of the heat exchanger HE2. The primary side of the heat exchanger HE2 is in its turn connected to the secondary side of the heat exchanger HE4 already mentioned.

A two-substance mixture of water and ammonia is used as the working medium in the device 1, which thus exhibits a non-isothermic vaporization and condensation. After the condenser HE1 the working medium is in a liquid state as a liquid working medium flow 13. With the aid of the pump 3 the entire flow of liquid working medium 13 is pumped up to a higher pressure and a pressurized liquid working medium flow 14 is created.

The pressurized liquid working medium flow 14 is fed to the primary side of the heat exchanger HE2 and heated up and partly vaporized by part condensation of a secondary-side expanded working medium flow 12 fed through the heat exchanger HE2, so that on the primary side after the heat exchanger HE2 a first partly vaporized flow of working medium

PCT/EP2005/051617
2004P03875WOAU

- 7 -

15 and on the secondary side a partly condensed, expanded flow of working medium 12a are present. The proportion of vapor in the first partly vaporized flow of working medium 15 is 15% for example.

The first partly vaporized flow of working medium 15 is fed without further heating to the secondary side of the heat exchanger HE4.

On the primary side hot thermal water 20 flows through the heat exchanger HE4. In the heat exchanger HE4 the first partly vaporized working medium flow 15 is further vaporized by the cooling down of the thermal water 20 and a second partly vaporized working medium flow 18 created. The second partly vaporized working medium flow 18 is fed to the separator 4, in which the vapor phase 10 is separated from the liquid phase 19 of the second partly vaporized working medium flow 18. The vapor phase 10 is subsequently expanded in the turbine 2 and its energy is converted into a usable form, e.g. into current by a generator not shown in the figure and an expanded vapor phase 11 created.

In the mixer 5 the expanded vapor phase 11 and the liquid phase 19 separated off in the separator 4 are merged again and an expanded working medium flow 12 is formed.

In this case no provision is made for an explicit transfer of heat from the liquid phase 19 to the first partly vaporized working medium flow 15, e.g. by means of a heat exchanger provided specifically for the purpose. The partly vaporized working medium flow 15 thus, before its further vaporization in heat exchanger HE4, has essentially the same temperature as it does after its creation by part condensation of the expanded working medium flow 12. "Essentially the same temperature" is taken in this case to mean that the temperature

PCT/EP2005/051617
2004P03875WOAU

- 8 -

difference only amounts to a few Kelvin and is caused for example by a slight cooling down of the first partly vaporized working medium flow leaving heat exchanger HE2 as a result of heat losses in the connecting pipes to heat exchanger HE4.

The expanded working medium flow 12 is partly condensed in heat exchanger HE2 and a partly condensed, expanded working medium flow 12a created. The partly condensed, expanded working medium flow 12 is subsequently condensed in condenser HE1 with the aid of the (incoming) flow of cooling water 25 and the liquid working medium flow 13 created. The heat transferred by the condensation of the expanded working medium flow 12a to the cooling water flow 25 is removed by the outgoing cooling water flow 26.

Figure 2 shows a cycle calculation for a device for execution of the thermodynamic cycle process, which essentially corresponds to the device shown in Figure 1 and has additionally only been supplemented by a number of valves 27. As initial conditions for the calculations an ammonia concentration in the water of 95% (with a liquid, fully condensed working medium) and a thermal water flow 20 with a temperature of 120°C as well as a mass flow of 141.8 kg/s are assumed. The temperature of cooling water flow 25 is 9.4°C. As can be seen from FIG 1 and 2, there is no provision for changes in the concentration of ammonia to increase the level of efficiency, apart from through the separation of the vapor phase from the liquid phase after the heat transfer from the external heat source into the ammonia concentrations which are different in the two phases.

Table 1 shows for a number of selected flows of the cycle the result of the cycle calculation, with the power of the heat exchangers being selected in accordance with Table 2.

PCT/EP2005/051617
2004P03875WOAU

- 9 -

Table 1:

Flow	Temperature (°C)	Enthalpy (kJ/kg)	Mass flow (kg/s)	Pressure (bar)
10	106.7	1507.8	27.59	22.3
11	56.51	1355.9	27.59	7.158
13	13.13	24.8	27.6	6.9
15	53.52	221.4	27.6	23.26
20	119.9	-1997.8	141.8	20
22	57.45	-2250.6	141.8	19.61

Table 2:

Heat exchanger	Power (kW)
HE1 (condenser)	31.0
HE2	5.3
HE4	34.5
Total	70.8

The temperature of the first partly vaporized working medium flow 15 before entry into the heat exchanger HE4 is 53.52°C and is thus the same temperature as after leaving the heat exchanger HE2. The electrical power which can be generated under these conditions with the aid of the turbine 2 amounts to 4033 kW.

The pressure of the vapor phase 10 before entry into the turbine 2 amounts to 22.3 bar and the pressure of the expanded, vapor phase 11 on exit from the turbine 2 amounts to 7.158 bar. The selected inlet pressure of 22.3 bar and the pressure ratio of appr. 3.1 between the pressure of the vapor phase before and after the turbine 2 enables a conventional single-stage high-efficiency turbine to be used as turbine 2, with the associated cost and efficiency level benefits.

PCT/EP2005/051617
2004P03875WOAU

- 10 -

Figure 3 by contrast shows the circuit of a device 30 known in the prior art as KCS 34 (Kalina Cycle System 34) for executing a thermodynamic cycle process. For better comparison of the known device 30 with the inventive device shown in FIG 1, components and flows which correspond to each other are identified by the same reference symbols. Device 30 differs from the inventive device shown in FIG 1 in having an additional, heat exchanger HE3 connected on the primary side between heat exchanger HE2 and heat exchanger HE4 and on the secondary side between separator 4 and mixer 5. With the aid of heat exchanger HE2 the pressurized, liquid working medium flow 14 is heated up by part condensation of the expanded working medium flow 12 and a heated (liquid) working medium flow 15 created. The heated working medium flow 15 is subsequently further heated by means of the heat exchanger HE3 by cooling down of the liquid phase 19 and thereby a further heated working medium flow 15a created.

Figure 4 shows a cycle calculation for a device known from the prior art which essentially corresponds to the device 30 shown in Figure 3 and has additionally only been supplemented by a number of valves 27. The initial conditions assumed for the calculations were an ammonia concentration in the water of 89.2% and - as in the case of the cycle calculation of Figure 2 - a thermal water flow 20 with a temperature of 120°C as well as a mass flow of 141.8 kg/s. The temperature of cooling water flow 25 is 9.4°C.

Table 3 shows for a number of selected flows of the cycle the result of the cycle calculation, with the power of the heat exchangers being selected in accordance with Table 4.

PCT/EP2005/051617
2004P03875WOAU

- 11 -

Table 3:

Flow	Temperature (°C)	Enthalpy (kJ/kg)	Mass flow (kg/s)	Pressure (bar)
10	115	1487.2	20.71	32.41
11	43.23	1294.5	20.71	6.775
13	13.16	-18.52	24.3	6.5
15	39	105.4	24.3	34.4
15a	48.67	153.5	24.3	33.72
20	119.9	-1997.8	141.8	20
22	70.46	-2196.3	141.8	19.61

Table 4:

Heat exchanger	Power (kW)
HE1 (condenser)	24.1
HE2	2.7
HE3	1.2
HE4	28.1
Total	55.1

The electrical power that can be generated in this case amounts to only 3818 kW. The obtainable electrical power is thus higher in the case of the inventive cycle according to FIG 1 and 2 by 5.6% than in the case of the cycle process known from the prior art.

The heated working medium flow 15 which leaves heat exchanger HE2 at a temperature of 39°C is further heated up in heat exchanger HE3 through cooling down of the liquid phase 19 to 48.87°C and fed as working medium flow 15a to heat exchanger HE4.

Whereas in the known case the temperature of the discharged thermal water 22 is still 70.46°C, in the case of the

PCT/EP2005/051617
2004P03875WOAU

- 12 -

inventive cycle process as shown in FIG 2 the discharged thermal water 22 only has a temperature of 57.45°C. In the case of the inventive cycle process comparatively more energy can thus be extracted from the thermal water.

As a result of the pressure of the vapor phase 10 at the input of the turbine 2 of 32.41 bar and of the pressure ratio of 4.8 between the pressure of the vapor phase at the input of the turbine 2 and the pressure of the expanded vapor phase 11 at the output of the turbine, a conventional single-stage turbine cannot be used in the case of the cycle shown in FIG 4. Either two conventional single-stage turbines connected in series must then be used, or a single turbine specifically suitable for high pressures and pressure ratios greater than 4 must be used, which in both cases is associated with higher costs and with efficiency losses compared to a single conventional turbine.

The increased heating surface requirement of 28.5% also resulting from the increased heat exchanger power results in a greater need for investment. These increased costs can however be compensated for in a large part by the simplified pipework and the omission of heat exchanger HE3, so that the plant costs overall remain essentially the same.

The invention has been described above with reference to preferred exemplary embodiments, but can generally be seen as not being restricted to these exemplary embodiments. Instead there is the option of a plurality of variations and modifications of the invention or of these exemplary embodiments. For example - as also occurs in the typical circuit shown in FIG 2 - additional valves can be connected into the circuit.

20365-5058

- 13 -

CLAIMS:

1. Method for executing a thermodynamic cycle process with at least the following steps:

pumping a flow of liquid working medium at an
5 increased pressure and forming a pressurized, liquid working medium flow;

heating up and part vaporization of the
pressurized, liquid working medium flow by part condensation
of an expanded working medium flow and creation of a first
10 partly vaporized working medium flow and of a partly
condensed, expanded working medium flow;

further vaporization of the partly vaporized
working medium flow with heat which is transferred from an
external heat source, and creation of a second at least
15 partly vaporized working medium flow;

separation of a liquid phase from a vapor phase of
the second at least partly vaporized working medium flow;

expansion of the vapor phase conversion of its
energy into a usable form and creation of an expanded vapor
20 phase;

mixing of the liquid phase with the expanded vapor
phase and formation of the expanded working medium flow;

complete condensation of the partly condensed,
expanded working medium flow and creation of the liquid
25 working medium flow.

2. Method in accordance with claim 1, with the
pressure of the vapour phase amounting to less than 24 bar.

20365-5058

- 14 -

3. Method in accordance with claim 1 or 2, with the pressure of the vapor phase being three to four times as great as the pressure of the expanded vapor phase.
4. Method in accordance with any one of claims 1 to 5 3, with a multi-substance mixture being used as the working medium.
5. Method in accordance with claim 4, with a two-substance mixture, especially an ammonia-water mixture, being used as the multi-substance mixture.
- 10 6. Method in accordance with any one of claims 1 to 5, with a geothermal liquid, especially thermal water, being used as the external heat source.
7. Method in accordance with any one of claims 1 to 6, with the heat source having a temperature of 100°C to 15 140°C.
8. Device for executing a thermodynamic cycle process, especially for executing the method in accordance with any one of claims 1 to 7, with at least
- a pump for pumping a flow of liquid working medium
20 at an increased pressure and creating a pressurized liquid working medium flow;
- a first heat exchanger for creating a first partly vaporized working medium flow by heating up and part vaporization of the pressurized liquid working medium flow
25 through part condensation of an expanded working medium flow;
- a second heat exchanger for creating a second at least partly vaporized working medium flow through further vaporization of the first partly vaporized working medium

20365-5058

- 15 -

flow with heat which is transferred from an external heat source;

a separator for separation of a liquid phase from a vapor phase of the second at least partly vaporized
5 working medium flow;

a device, especially a turbine, for expanding the vapor phase, converting its energy into a usable form and creating an expanded vapor phase;

a mixer for mixing the liquid phase with the
10 expanded vapor phase and creating an expanded working medium flow;

a third heat exchanger for completely condensing the partly condensed, expanded working medium flow and creating the liquid working medium flow.

15 9. Device in accordance with claim 8, with the pressure of the vapour phase amounting to less than 24 bar.

10. Device in accordance with claim 8 or 9, with the pressure of the vapor phase being three to four times as great as the pressure of the expanded vapour phase.

20 11. Device in accordance with any one of claims 8 to 10, with the working medium consisting of a multi-substance mixture.

12. Device in accordance with claim 11, with the multi-substance mixture being a two-substance mixture,
25 especially an ammonia-water mixture.

13. Device in accordance with any one of claims 8 to 12, with a geothermal liquid, especially thermal water, as external heat source.

20365-5058

- 16 -

14. Device in accordance with any one of claims 8 to 13, with the external heat source having a temperature of 100°C to 140°C.

FETHERSTONHAUGH & CO.

OTTAWA, CANADA

PATENT AGENTS

PCT/EP2005/051617
2004P03875WOAU

1 / 4

FIG 1.

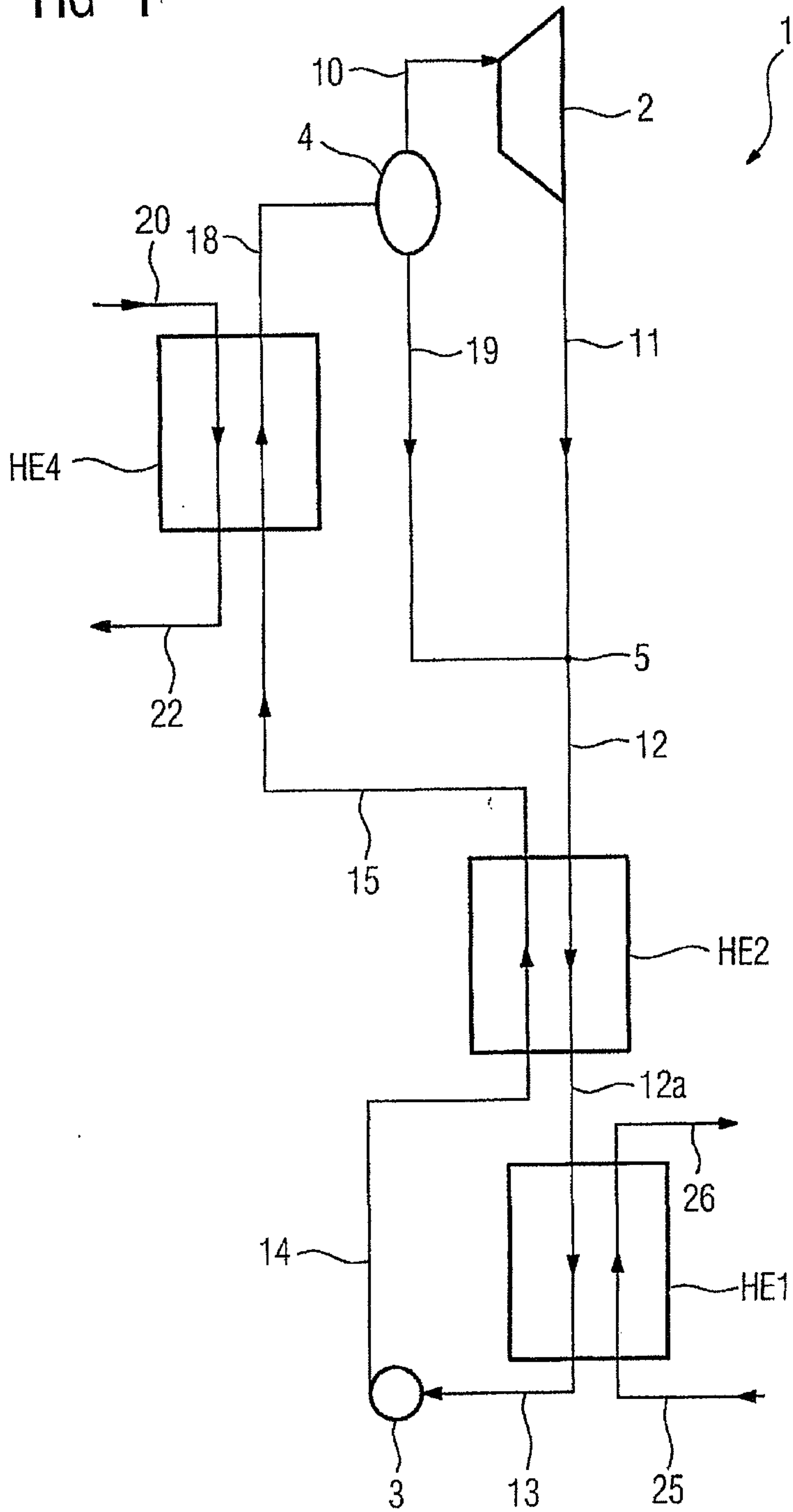

PCT/EP2005/051617
2004P03875WOAU

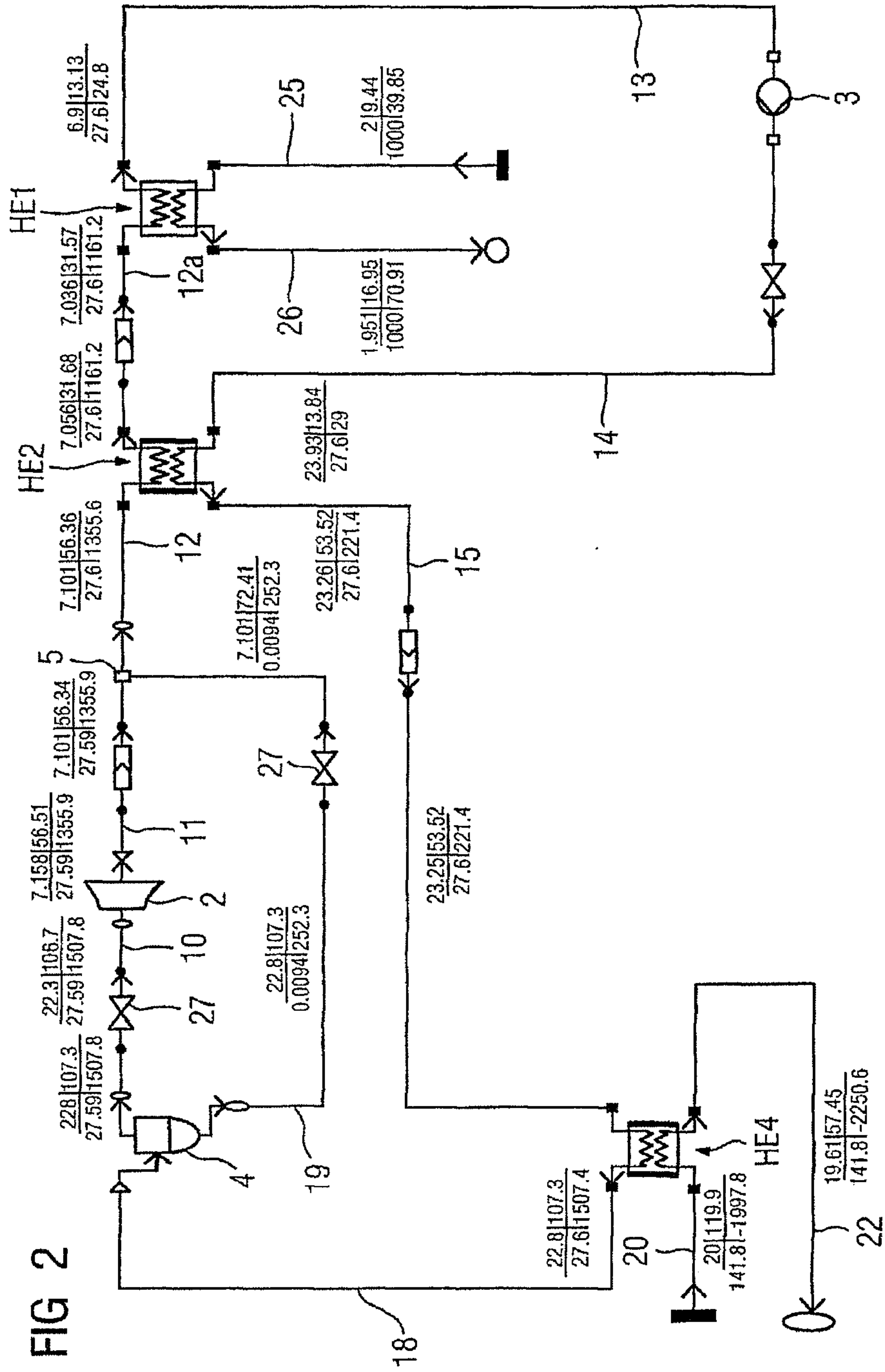
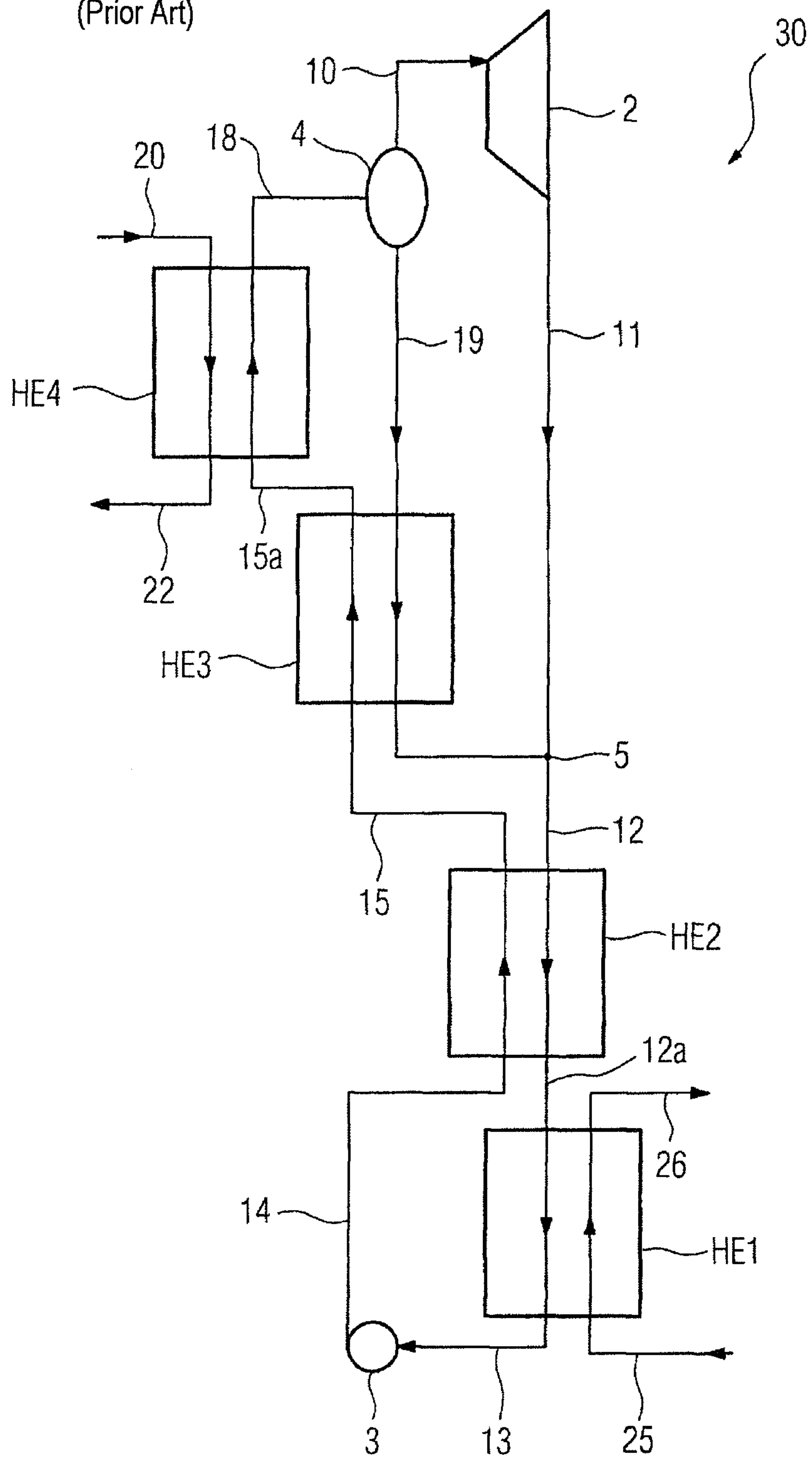

FIG 3

(Prior Art)



PCT/EP2005/051617
2004P03875WOAU

4/4

