

(19) AUSTRALIAN PATENT OFFICE

(54) Title
Improvements in or relating to tube couplings

(51)⁶ International Patent Classification(s)
F16L 21/06 (2006.01) 1BHAU F16L
F16L 19/08 (2006.01) 19/08
F16L 37/092 20060101ALI2006010
(2006.01) 1BHAU F16L
F16L 21/06 37/092
20060101AFI2006010 20060101ALI2006010
1BHAU

(21) Application No: 2002301873 (22) Application Date: 2002 .11 .07

(30) Priority Data

(31) Number	(32) Date	(33) Country
0126798.8	2001 .11 .07	GB

(43) Publication Date : 2003 .07 .10

(43) Publication Journal Date : 2003 .07 .10

(71) Applicant(s)
John Guest International Limited

(72) Inventor(s)
Guest, John Derek

(74) Agent/Attorney
Davies Collison Cave, 1 Nicholson Street, Melbourne, VIC, 3000

(56) Related Art
DE3525502

ABSTRACT

5 The disclosure relates to a tube coupling to
receive and hold a tube comprising a coupling body
(10) having a throughway (11) open at one end (12) to
receive an end portion of tube, an annular step (28)
in the throughway facing the open end to provide an
10 end stop for a tube end, and an end cap (13) engaging
the coupling body for axial movement between forward
and retracted positions on the body. The end cap has
an opening (20) for the end portion of the tube to
extend therethrough and a tube locking collet (21) in
15 the cap to permit entry of a tube into the cap and to
resist withdrawal. An annular seal (29) is located in
the coupling body adjacent the annular step, the seal
having an inner annular portion (30) with which the
tube end is engageable and an outer annular portion
20 (31), and a sleeve (32) between the locking device and
seal to compress the outer annular portion of the seal
axially in response to forward movement of the end cap
to cause the inner portion of the seal to be pressed
into sealing engagement with the tube end.

25

: 335561: GCB: LMC: LONDONS

**AUSTRALIA
PATENTS ACT 1990
COMPLETE SPECIFICATION**

NAME OF APPLICANT(S):

John Guest International Limited

ADDRESS FOR SERVICE:

DAVIES COLLISON CAVE
Patent Attorneys
1 Little Collins Street, Melbourne, 3000.

INVENTION TITLE:

Improvements in or relating to tube couplings

The following statement is a full description of this invention, including the best method of performing it known to me/us:-

- la -

This invention relates to tube couplings which may be single or multiple tube couplings providing inline, elbow or T-couplings or tube closures.

5 Our "Speedfit" tube connector (the subject of UK Patent No. 1520742) has a coupling body with a throughway open at one end and a tapered cam surface in the open end to receive a collet for locking a tube in the coupling. The collet is compressed against the tube by a slight withdrawal of the tube and collet from the coupling body which locks the tube in the coupling body. The collet can be depressed into the body to release the tube.

10 Our "Superseal" connector (the subject of our UK Patent No. 2167147) has a separate sleeve screwed onto the open end of the coupling body in which the tapered cam is formed. By screwing the sleeve onto the coupling body the gripping action of the collet on the tube is increased. Also the collet becomes locked up in the coupling body and cannot be depressed to release the tube.

15 Our "Speedfit/Superseal" coupling (the subject of European Patent Publication No. 0945662) comprises a coupling body having a throughway open at one end to receive an end portion of a tube and having an internal cam surface tapering towards the open end in which a collet is located for locking the tube in the coupling body by engagement with the tapered cam surface, and having step means to limit entry of the collet into the throughway, the coupling body having a main body the throughway of which receives the end of a tube and contains said step means to limit insertion of the collet and an end cap in screw threaded engagement with the main body containing said open end to the throughway and the tapered cam surface, and indexing means between the end cap and main body to

- 2 -

define different positions of rotational adjustment in the first of which a tube can be inserted and, by depressing the collet into the coupling body, released from the coupling body and in the second of which the
5 collet is engaged with the step means to prevent the collet being depressed into the coupling body to release the tube. In the preferred arrangement the end cap has an internally threaded sleeve portion encircling and in screw threaded engagement with an
10 external thread on the main body.

In the latter construction, an "O" ring seal is provided in the throughway in the coupling body to engage and seal with the outer surface of the tube. The seal is spaced from the ends of the collet by a
15 washer or sleeve. This arrangement provides small cavities between adjacent components in which liquids can penetrate and become trapped and difficult to remove by cleaning. Such entrapped liquids can deteriorate over a period of time and cause
20 contamination in subsequent liquid flowing through the coupling.

Our European Patent Publication No. 1233225 discloses a tube coupling to receive and hold a tube comprising a coupling body having a throughway open at
25 one end to receive a tube, an annular step in the throughway facing the open end to receive an end of a tube, an end cap engaging the coupling body for axial movement between forward and retracted position on the coupling body, the end cap having an opening for the
30 tube to extend through, a seal located in the coupling body between the step and the open end of the body and in the form of an annular sleeve encircling the throughway, the seal having an out turned annular flange at one end which engages with the annular step
35 to receive and seal with an end of the tube inserted into the throughway and means operable by the end cap to compress the sleeve around the outer surface of the

2002301873 09 Mar 2007

tube adjacent said end of the tube to form a seal with the end of the tube.

This arrangement provides a combination of the "Speedfit" and "Superseal" features referred to above in which any potential leak paths from an end of a tube in the coupling body is minimised and recesses or cavities between adjacent components in the leak path are minimised to present a substantially clean, smooth internal surface to the outer side of the tube connected in the coupling.

The latter arrangement is, however, relatively complicated requiring inter fitting components which present some manufacturing difficulties particularly for small sizes of tube couplings.

According to the present invention, there is provided a tube coupling to receive and hold a tube comprises:

a coupling body having a throughway open at at least one end to receive an end portion of the tube;

an annular step in the throughway facing said open end to provide an end stop for a tube end;

an end cap engaging the coupling body for axial movement between forward and retracted positions on the body, the end cap having an opening for the end portion of the tube to extend therethrough and a tube locking device in the cap to permit entry of a tube into the cap and to resist withdrawal of the tube comprising a collet having an annular head disposed outside the end cap and axially extending arms projecting through the opening into the end cap and to engage a cam surface in the end cap which tapers towards the opening to press the collet arms into gripping engagement with a tube with outward movement of the collet in the end cap in the retracted position of the end cap;

an annular seal located in the coupling body against the annular step;

and an annular sleeve provided between the ends of the arms of the tube locking device and the seal for compressing the seal axially in response to forward movement of the locking device with the end cap, the sleeve having a cylindrical inner surface;

wherein the seal has an outer annular portion engaged by the annular sleeve and an inner annular portion to be

2002301873 09 Mar 2007

- 4 -

engaged by the end of the tube, the seal being located against the step so that both inner and outer annular portions of the seal are supported by the step whereby moving the end cap into the forward position causes the
5 collet arms to engage with the annular sleeve pressing the sleeve further into the coupling body against the outer annular portion of the seal and thereby forcing the inner annular portion of the seal into engagement with the end of the tube held by the collet.

10 The annular seal may be in the form of an annular disc having an inner and an annular portion for engagement by the tube end, and an outer annular portion for engagement by said compressing means.

15 More specifically, the outer portion of the annular seal may have an annular projection facing the open end of the coupling body with which said compressing means is engageable, the end portion of the tube engaging the inner annular portion of the seal within the projection so that
20 sealing engagement with the outer surface of the tube.

The projection on the outer annular portion of the seal may comprise a shallow collar formed on the outer periphery of the seal within which the tube end may engage, the collar having a rounded end portion with
25 which the means to compress the outer portion of the seal engage.

Alternatively, the outer annular portion of the seal may have a toroidal shape project within which the end portion of the tube engages the seal and with which the means
30 to compress the outer portion of the seal engage the toroidal shaped projection when compressed the sealing against the outer surface of the tube end.

In any of the above arrangements the tube locking device in the cap may comprise an annular collet having a
35 plurality of resilient arms and the cap has a cam surface which tapers towards the open end of the cap with which the resilient arms of the collet are engageable to be pressed inwardly with movement of the collet towards the open end of the cap

- 5 -

to force the arms into gripping engagement with the tube.

In the latter arrangement, the ends of the arms of the collet may be engageable with the means to
5 compress the outer portion of the sealing ring so that when the cap is moved in a forward direction on the coupling body, the collet moving with the cap forcing the compression means to act on the outer portion of the seal to compress the seal into sealing engagement
10 with the end of the tube.

Also in any of the above arrangements the interengaging means may be provided between the cap and coupling body which, on rotation of the cap in one direction drives the cap forwardly on the coupling
15 body and in the opposite direction rearwardly on the coupling body.

By way of example, the coupling body may have a spirally wound groove, and the cap has a projection or projections engaging in the groove to cause the cap to
20 move forwardly or rearwardly on the body with rotation of the cap in one or other direction.

More specifically, the spirally wound groove on the coupling body may extend approximately half way round the coupling body and the cap may have a
25 projection engaging in the groove so that a half turn of the cap with respect to the coupling body advances or retracts the cap over the total travel of the cap permitted by the groove.

In the latter arrangement detent means may be
30 provided for retaining the projection in the fully advanced or fully retarded position in the helically wound groove.

The following is a description of some specific
35 embodiments to the invention, reference being made to the accompanying drawings in which:-

Figure 1 is an exploded perspective view of a

- 6 -

straight double-ended connector for two lengths of tube;

Figure 2 is a sectional view through the coupling of Figure 1;

5 Figure 3 is a sectional view through a first modified version of the coupling of Figure 1; and

Figure 4 is a sectional view through a second modified version of the coupling

10 Referring firstly to Figures 1 and 2 of the drawings, there is shown a tube coupling which is generally of the form described and illustrated in our European Patent Publication No. 0945662. That
15 application discloses a tube coupling embodying features of our "Speedfit" tube connector which forms the subject of our UK Patent No. 1520742 with the features of our "Superseal" connector as described in our UK patent No. 2167147. The tube coupling
20 comprises a coupling body having a main body part and an end cap on the body part, and a collet for gripping a tube to be locked in the coupling body located in the end cap with a seal for engaging the tube is located in the main body part. In one position of the end cap on the main body part, a tube can be locked in or
25 released from the coupling body by the collet as described in our UK Patent Publication No. 1520742. The gripping action of the collet on the tube can be enhanced by screwing the end cap further onto the main body part of the coupling as described in our UK
30 Patent Publication No. 2167147 and means are provided as described in our European Patent Publication No. 0945662 to index the movement of the end cap with respect to the main body part so that the end cap is readily adjustable between the first position in which
35 the tube can be engaged by a collet but readily released when required and a second position in which the tube is locked against release in the collet.

- 7 -

In accordance with the present invention, a tube connector comprises a coupling body 10 having a throughway 11 open at one end 12 to receive internally an end portion of a tube (not shown) and externally an end cap 13. The coupling body has a pair of helical grooves 14 spaced diametrically apart around the body, each having an axially extending entry 15 over a step 16. The grooves extend from the entry around and along the coupling body to terminate at inner ends 17 adjacent an enlarged integral collar 18 encircling the coupling body. The caps 13 has lugs 19 spaced diametrically across the lugs 14 on the inner periphery of the cap to engage in the grooves 14. The cap 13 is presented to the coupling body with the lugs 19 in line with the entry ends 15 to the grooves. The lugs are snapped over the steps 16 by an axial movement of the cap following which the cap can be tightened onto the coupling body by rotation. As the cap rotates the lugs 18 traverse the grooves 14 drawing the cap along the body until the lugs reach the inner ends 17 of the grooves adjacent the central block 11a.

The end cap 13 has an open end 20 in which a collet indicated generally at 21 is engaged. The collet comprises an annular portion 22 which projects from the open end 20 of the end cap and is formed with an out turned annular flange or head 23 which can be manually gripped for manipulating the collet. A portion of the collet extending into the throughway in the end cap has axially extending resilient arms 24 with which terminate in heads 25 having integral barbs or teeth 26 on the inner sides thereof to grip the tube extending through the collet.

There is a tapered cam surface 27 formed in the end cap with which the heads 25 of the collet are engageable to be compressed inwardly as the collet is drawn outwardly of the throughway to cause the barbs

- 8 -

26 on the inner sides of the heads of the collet to grip and engage a tube extending through the collet.

The throughway 11 in the main body part is formed with a step 28 facing the open end of the coupling body to receive an end of a tube to be connected in the coupling body. An annular seal 29 is positioned in the coupling body against the annular step 28. The seal has an inner annular portion 30 to receive an end of a tube to be secured in the coupling body as described later. The end of the tube is cut square to ensure full engagement with the seal. The seal has an outer annular portion 31 and an annular sleeve 32 is slidably located in the throughway between the outer portion 31 of the seal and the heads 25 of the collet.

As shown in Figure 2 of the drawings the end cap 13 is in its retracted position in which a tube is received. The tube is pushed fully home into the coupling body by turning the end cap 13 through approximately a half turn of movement with the tube locked in the cap by the collet. The endcap advances along the coupling body and the end of tube is moved in engagement with the seal 31. The heads 25 of the ends of the arms 14 of the collet engage the adjacent end of the sleeve 32 forcing the sleeve further into the coupling body. The sleeve 32 is forced by the collet against the outer portion 31 of the seal to compress the seal and force the inner portion 30 into engagement with the end of the tube.

One end only of the coupling body has been described and the other end of the body illustrated which is an in-line connector is similarly formed.

Figure 3 of the drawings shows a further arrangement in which the seal 29 is formed with an axially projecting collar 33 around the outer peripheral portion 31. The collar has a rounded end 34 with which the sleeve is engageable. The end of the tube engages the seal within the collar and

- 9 -

pressure of the sleeve on the collar forces the collar inwardly to seal with the outer periphery of the tube in addition to the end seal on the tube.

Figure 4 shows a still further arrangement in which the seal 29 has a raised toroidal shaped projection 35 around the outer portion of the seal with which the sleeve is engageable to press the toroid shaped projection in engagement with the periphery of the tube. Other features of the arrangement are as previously described with reference to Figures 1 and 2.

Throughout this specification and the claims which follow, unless the context requires otherwise, the word "comprise", and variations such as "comprises" and "comprising", will be understood to imply the inclusion of a stated integer or step or group of integers or steps but not the exclusion of any other integer or step or group of integers or steps.

The reference to any prior art in this specification is not, and should not be taken as, an acknowledgement or any form of suggestion that that prior art forms part of the common general knowledge in Australia.

2002301873 09 Mar 2007

THE CLAIMS DEFINING THE INVENTION ARE AS FOLLOWS:

1. A tube coupling to receive and hold a tube comprises:
 - a coupling body having a throughway open at at least
 - 5 one end to receive an end portion of the tube;
 - an annular step in the throughway facing said open end to provide an end stop for a tube end;
 - an end cap engaging the coupling body for axial movement between forward and retracted positions on the
 - 10 body, the end cap having an opening for the end portion of the tube to extend therethrough and a tube locking device in the cap to permit entry of a tube into the cap and to resist withdrawal of the tube comprising a collet having an annular head disposed outside the end cap and axially extending arms
 - 15 projecting through the opening into the end cap and to engage a cam surface in the end cap which tapers towards the opening to press the collet arms into gripping engagement with a tube with outward movement of the collet in the end cap in the retracted position of the end cap;
 - 20 an annular seal located in the coupling body against the annular step;
 - and an annular sleeve provided between the ends of the arms of the tube locking device and the seal for compressing the seal axially in response to forward movement of the
 - 25 locking device with the end cap, the sleeve having a cylindrical inner surface;
 - wherein the seal has an outer annular portion engaged by the annular sleeve and an inner annular portion to be engaged by the end of the tube, the seal being located
 - 30 against the step so that both inner and outer annular portions of the seal are supported by the step whereby moving the end cap into the forward position causes the

2002301873 09 Mar 2007

- 11 -

collet arms to engage with the annular sleeve pressing the sleeve further into the coupling body against the outer annular portion of the seal and thereby forcing the inner annular portion of the seal into engagement with the end of
5 the tube held by the collet.

2. A tube coupling as claimed in claim 1, wherein the annular seal is in the form of an annular disc having an inner annular portion for engagement by the tube end, and an
10 outer annular portion for engagement by the sleeve.

3. A tube coupling as claimed in claim 1 or claim 2, wherein the outer annular portion of the annular seal has an annular projection facing the open end of the coupling body
15 with which the sleeve is engageable, the end portion of the tube engaging the inner annular portion of the seal within the projection so that compression of the projection presses the projection into sealing engagement with the outer surface of the tube.

20
4. A tube coupling as claimed in claim 3, wherein the projection on the outer annular portion of the seal comprises a shallow collar formed on the outer periphery of the seal within which the tube end may engage, the collar
25 having a rounded end portion with which the sleeve engages.

5. A tube coupling as claimed in claim 3, wherein the outer peripheral portion of the seal has a toroidal shaped projection within which the end portion of the tube engages
30 and with which the sleeve engages for compressing the outer portion of the seal engages, the toroidal shaped projection being compressed into sealing engagement against the outer

2002301873 09 Mar 2007

- 12 -

surface of the tube end by the sleeve.

6. A tube coupling substantially as hereinbefore described with reference to the accompanying drawings.

1/4

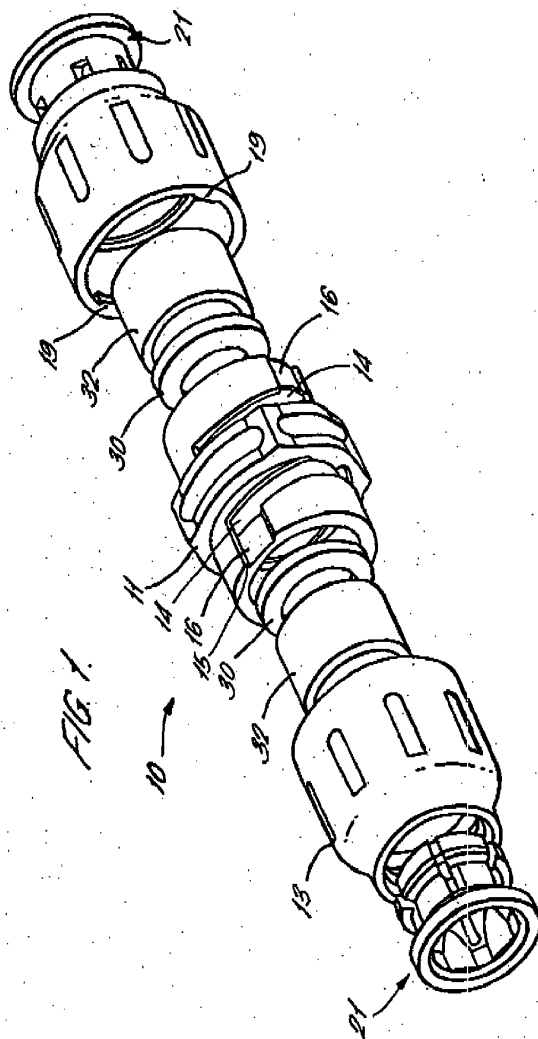

2/4

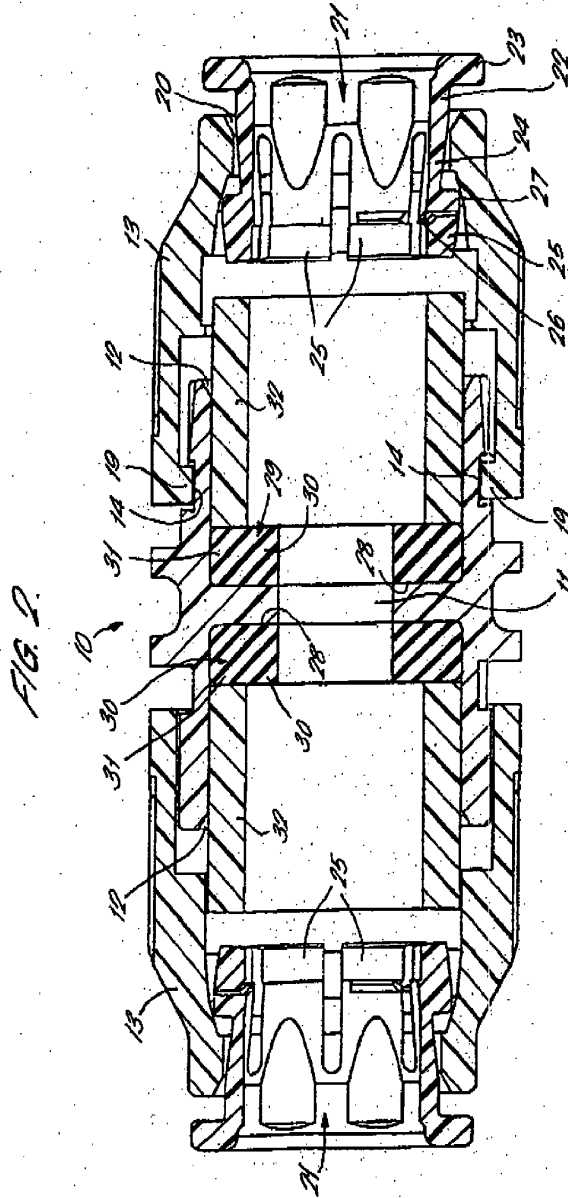

3/4

FIG. 3.

