

(19) AUSTRALIAN PATENT OFFICE

(54) Title
Drink dispenser assembly and container for drink and drink dispensing line

(51)⁶ International Patent Classification(s)
B67D 1/06 (2006.01) 7BMAU **B67D**
B67D 1/00 (2006.01) 1/04
B67D 1/04 (2006.01) 20060101ALI2006042
B67D 1/08 (2006.01) 7BMAU **B67D**
B67D 1/14 (2006.01) 1/08
B67D 1/06 20060101ALI2006042
20060101AFI2006042 7BMAU **B67D**
7BMAU **B67D** 1/14
1/00 20060101ALI2006042
20060101ALI2006042 7BMAU

(21) Application No: 2006201657 (22) Application Date: 2006 .04 .20

(43) Publication Date : 2006 .05 .11

(43) Publication Journal Date : 2006 .05 .11

(62) Divisional of:
2001264403

(71) Applicant(s)
Heineken Technical Services B.V.

(72) Inventor(s)
Van Der Klaauw, Guido Petrus Johannes, Bax, Bart Jan, Van Duuren, Marius Corstiaan

(74) Agent/Attorney
FB Rice & Co, Level 23 200 Queen Street, Melbourne, VIC, 3000

(56) Related Art
WO 00/03944
GB 2176766

ABSTRACT

The invention relates to a drink dispenser assembly comprising a dispenser device provided with a dispensing head for accommodating a dispensing line and a
5 container containing drink, in particular carbonated drink, connected during use to the dispensing line, which has a coupling element at an outlet end for connection to the dispensing head. The drink dispenser assembly is characterised in that the coupling
element comprises a shut-off valve that can be closed when placing the outlet end of
the dispensing line into the dispensing head and, respectively, removing the outlet end
10 of the dispensing line from the dispensing head.

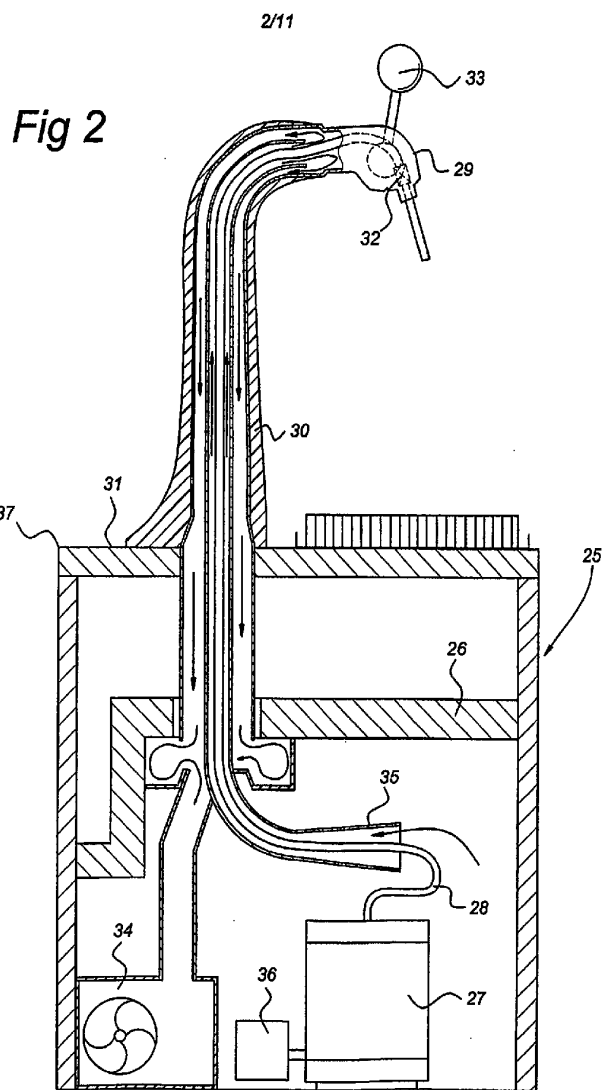

AUSTRALIA
Patents Act 1990

HEINEKEN TECHNICAL SERVICES B.V.

COMPLETE SPECIFICATION
STANDARD PATENT

Invention Title:

*Drink dispenser assembly and container for drink and drink
dispensing line*

The following statement is a full description of this invention including
the best method of performing it known to us:-

2006201657 20 Apr 2006

DRINK DISPENSER ASSEMBLY AND CONTAINER FOR DRINK AND DRINK DISPENSING LINE

This application is a divisional application of Australian Application No. 2001264403, the contents of which are incorporated herein by reference.

5 The invention relates to a drink dispenser assembly comprising: a dispenser device provided with a dispensing head for accommodating a dispensing line, and a container containing drink, in particular carbonated drink, connected during use to the dispensing line which has a coupling element at an outlet end for connection to the dispensing head.

10 A drink dispenser assembly of this type is disclosed in PCT/NL 99/00454. The known dispenser device comprises a chill chamber in which a pack containing carbonated drink, such as beer, can be placed. The pack containing carbonated drink comprises an outer container made of plastic and an inner, flexible bag with the carbonated drink therein. The flexible bag is connected via a filling and dispensing head to the neck of the outer container. The dispensing head is provided with a first, relatively broad fill channel to which a filling head of a fill line can be connected in order to fill the flexible bag. After 15 filling and removing the filling head from the fill line, the fill channel of the filling and dispensing head is closed by a spring-loaded valve. A second, relatively narrow dispensing channel of the filling and dispensing head is connected to a flexible hose that extends at right angles to the longitudinal direction of the container. Before the container is placed in the chill chamber of the drink dispenser device, the dispensing channel is also closed by a 20 spring-loaded valve. A plastic outlet component at right angles that is provided with a plate displaying a make is fixed to the end of the flexible hose, which outlet component can be placed in a receiver component in the dispensing head of the drink dispenser device. The dispensing head comprises two hingeable parts, which delimit a feed-through channel for the flexible hose, and a shut-off valve connected to a tap handle. The shut-off valve 25 comprises a spring-loaded clamping mechanism that by operation of the tap handle is able to squeeze shut the flexible hose in the feed-through channel and is able to release it.

After the flexible hose has been placed in the feed-through channel the dispensing head is closed and the tap handle is placed in the closed position. A cover on the dispenser device can then be closed and pressure means, such as a compressor, can be connected to 30 the container to feed a pressure medium into the space between the wall of the outer container and the flexible bag. On closing the cover of the chill chamber in the dispenser device, the dispensing channel of the filling and dispensing head is opened, so that the contents of the flexible bag are driven into the flexible hose. The flexible hose is released

by opening the tap handle and assumes its free, undeformed cross-section and the carbonated drink is dispensed from the dispensing head under pressure. The known dispenser device is also provided with a cooler, such as a Peltier element, for cooling the drink.

5 The known device has the disadvantage that controlled dispensing through the flexible hose is possible to only a limited extent and that dispensing is dependent on the flexible characteristics of the hose. If the drink is carbonated drink, such as beer, this can lead to undesired frothing.

10 If the tap handle is not closed when the container containing drink is placed in the dispenser device, undesired dispensing of drink can take place with the known dispenser device. Furthermore, drink will also be able to leak from the dispensing line when the empty container is removed from the dispenser device. The dispensing head and other components of the dispensing device can be soiled as a result. Consequently the known device has to be cleaned relatively frequently. Moreover, as a result of the
15 contamination the life of the drink can be shortened.

Finally, after dispensing a quantity of drink, after closing the tap handle drink can still leak for a prolonged period from that part of the flexible hose that is located downstream of the shut-off valve.

20 One aim of the invention is to provide a drink dispenser assembly, as well as a container and a dispensing line of the abovementioned type, with which these problems are solved.

A further aim of the invention is to provide a drink dispenser assembly that requires very little maintenance, requires little cleaning and provides a hygienic environment with a relatively long life for the drink.

25 The present invention provides a drinks dispenser assembly comprising:
a dispenser device provided with a dispensing head for accommodating a flexible dispensing line, and a container containing carbonated drink, connected during use to the flexible dispensing line which has a coupling element at an outlet end for connection to the dispensing head, characterised in that the coupling element
30 comprising a shut off valve that, when it is connected to the dispensing head, can be opened and closed via the dispensing head for dispensing the carbonated drink through the valve and which shut-off valve can be closed while placing the outlet end of the dispensing line into the dispensing head and respectively, removing the outlet end of the dispensing line from the dispensing head, the shut off valve comprising a first
35 sleeve and a second sleeve, which is concentric with respect to the first sleeve, which first sleeve is provided with an inlet to an upstream part of the dispensing line and an

outlet, the second sleeve being provided with an inlet which interacts with the outlet of the first sleeve and with an outlet, coupling means being arranged on one of the sleeves which can be moved by the coupling means between a flow position, in which the outlet of the first sleeve is in fluid communication with the inlet of the second sleeve, and a shut-off position in which the outlet of the first sleeve is closed off by the second sleeve.

The present invention also provides a container provided with a carbonated drink, having a flexible dispensing line which is connected to or can be connected to the container and has a coupling element close to one end for connection to a dispensing head of a drink dispensing device, characterised in that the coupling element comprises a shut-off valve that, when it is connected to the dispensing head, can be opened and closed via the dispensing head for dispensing the carbonated drink through the valve and which shut-off valve can be closed while placing the end of the dispensing line into the dispensing head and, respectively, removing the end of the dispensing line from the dispensing head, the shut off valve comprising a first sleeve and a second sleeve, which is concentric with respect to the first sleeve, which first sleeve is provided with an inlet to an upstream part of the dispensing line and an outlet, the second sleeve being provided with an inlet which interacts with the outlet of the first sleeve and with an outlet, coupling means being arranged on one of the sleeves which can be moved by the coupling means between a flow position, in which the outlet of the first sleeve is in fluid communication with the inlet of the second sleeve, and a shut-off position in which the outlet of the first sleeve is closed off by the second sleeve.

To this end the drink dispenser assembly according to the invention is characterised in that the coupling element comprises a shut-off valve that can be closed when placing the outlet end of the dispensing line into the dispensing head and, respectively, removing the outlet end of the dispensing line from the dispensing head.

Because the coupling element of the dispensing line, which can be placed in an unambiguous position in the dispensing head, is provided with a shut-off valve, controlled dispensing of the drink can be obtained. Especially if the drink is carbonated drink, such as beer, undesired frothing can be counteracted by this means. Furthermore, in contrast to the known flexible dispensing line, the flow characteristics through the dispensing line

according to the invention can be adjusted by sizing the dimensions and the stroke of the shut-off valve. Tap feel, the flow rate and the type of jet of drink can be accurately adjusted by this means.

5 The drink dispenser device, the container and the dispensing line according to the present invention are suitable for dispensing all types of drink, but are particularly suitable for dispensing carbonated drink, such as beer. In the illustrative embodiments given below reference is made to carbonated drinks by way of example.

10 Furthermore, the shut-off valve can be closed when placing the pack containing carbonated drink in the dispenser device, so that leakage of carbonated drink is prevented even if the tap handle is in the open position. The shut-off valve is closed when the empty or partially empty pack is removed from the dispenser device and leakage of drink, present in the flexible dispensing line, from the dispensing line is prevented. As a result a favourable microbiological environment is maintained and the need for frequent cleaning of the dispenser device decreases. Finally, as a result of the use of the shut-off valve in the
15 dispensing line a relatively simple filling and dispensing head can suffice for the container containing carbonated drink, which filling and dispensing head is provided with a dispensing channel with a simple closure, for example a breakable seal that is opened after placing the pack in the dispenser device and can no longer be resealed.

20 The dispensing line can be of rigid construction, but can also be telescopic or at least partially of flexible construction. The latter is preferred since this facilitates the positioning of the shut-off valve in the dispensing head. It is preferable to make the dispensing line of flexible plastic so that this constitutes a disposable or semi-disposable line that is thrown away after it has been used once or a number of times.

25 The dispensing line can be permanently connected to the container containing carbonated drink, but can also be provided with a coupling for detachable connection to the container.

30 The shut-off valve can be a normally closed shut-off valve, such as a slit valve in the flexible hose, that can be opened by compression by the tap handle, a separate plastic shut-off valve with a closed equilibrium position, a spring-loaded (ball) valve or an electromagnetic valve. The shut-off valve can, however, also comprise a tap or valve known per se and can be provided with an operating element by means of which it can be opened and closed by a user after it has been placed in the dispensing head.

Preferably, however, the shut-off valve is not provided with an operating element for

the user, but the dispensing head comprises an operating element, joined to the handle or knob, by means of which the shut-off valve can be detachably connected, so that the shut-off valve itself can have small dimensions. This has the advantage that the shut-off valve is not only of lightweight construction and has a small number of components, so that it can easily be made as a disposable item for once-only use, but that it can also easily be accommodated, stored and transported in the pack, it being possible, for example, to accommodate the dispensing line in the coiled state on top of or beneath the base of the pack containing carbonated drink.

Furthermore, as a result of the relatively small dimensions of the shut-off valve, which preferably has a cylindrical cross-section which is not much larger than the external diameter of the dispensing line, said shut-off valve can easily be fed through an - optionally cooled - guide tube of a drink dispenser device of a type that is described in Patent Application number 1015359 bearing the title "Tap device and container therefor, as well as method for the production thereof", which was filed on 31 May 2000 in the name of the Applicant. In such a dispenser assembly with guide tube, the compartment for accommodating the pack containing carbonated drink comprises a refrigerator located beneath a bar, the flexible dispensing line extending from the refrigerator to the pump, which carries the dispensing head. When connecting a new pack and associated dispensing line, which in this case can have a length of 1 metre or more, the shut-off valve at the end of the flexible dispensing line can easily be pushed through the guide tube to the dispensing head.

The operating element of the dispensing head can comprise a fork in which the shut-off valve can be fitted. The shut-off valve is provided with coupling means, for example in the form of a flange or a groove, which can be detachably connected to the fork.

In one embodiment the shut-off valve comprises a first sleeve and a second sleeve, which is concentric with respect to the first sleeve, which first sleeve is provided with an inlet to an upstream part of the dispensing line and an outlet, the second sleeve being provided with an inlet which interacts with the outlet of the first sleeve and with an outlet, coupling means being arranged on one of the sleeves which can be moved by the coupling means between a flow position, in which the outlet of the first sleeve is in fluid communication with the inlet of the second sleeve, and a shut-off position in which the outlet of the first sleeve is closed off by the second sleeve.

The dispensing line is opened and closed by relative rotation, translation, or a

combination thereof, of the sleeves by the operating element of the shut-off valve. A simple shut-off valve that is reliable in operation comprises sleeves that can be moved with respect to one another in the direction of the dispensing line. With such an "in line" shut-off valve the pressure of the carbonated drink can provide an additional closing force, a simple operating element can be used in the dispensing head for an accurately adjustable stroke, which can easily be adjusted for a tap handle, and the size of the shut-off valve can remain small.

By using a "can" shut-off valve that can be opened and closed in the axial direction of the dispensing line, which shut-off valve is pushed into its closed position by the pressure of the carbonated drink, a simple, compact shut-off valve that is reliable in operation is formed which is suitable for once-only use and which can easily be fitted in the dispensing head and can easily be removed therefrom.

The dispensing head can have a base section into which the shut-off valve can be placed. The shut-off valve can be provided with a protective cap which interacts with the base section, such that the shut-off valve is enclosed between the base section and the protective cap and is not accessible to the user during use.

The dispensing head is preferably divided into two halves which are hingeable with respect to one another and which delimit a feed-through channel in which the dispensing line can be placed.

Preferably, the hingeable halves are provided with a locking mechanism that can be released only when the shut-off valve is closed.

The outlet end of the dispensing line that is located downstream of the shut-off valve can consist of a relatively rigid plastic section with a peripheral groove or flange which interacts with a complementary flange or groove in the dispensing head for accurate positioning of the end of the dispensing line. If a cooling medium is fed through the dispensing head, as described in Patent Application no. 1015359 filed on 31 May 2000 in the name of the Applicant, the dispensing head is closed off by the dispensing line such that it is at least partially fluid-tight at the point where the dispensing line emerges from the dispensing head.

The outlet end of the dispensing line can be provided with a plate with, for example, the tradename of the drink thereon. This plate can be fitted in a chamber in the dispensing head, which chamber is provided with a window through which the plate is visible to the user. By this means the content of the pack containing carbonated drink that has been

placed in the dispenser device can easily be established.

Finally, in one embodiment the shut-off valve is provided with a vent which is closed when the shut-off valve is open and which connects the outlet end of the shut-off valve to the environment when the shut-off valve is closed. By this means, a vacuum arising after
5 dispensing drink and then closing the shut-off valve is released and all drink downstream of the closed shut-off valve will be dispensed rapidly from the outlet end of the dispensing line without significant subsequent dripping.

A few embodiments of a drink dispenser assembly according to the invention will be explained in more detail with reference to the appended, non-limiting drawing, in which:

10 Fig. 1 shows a diagrammatic cross-section of a first embodiment of a drink dispenser assembly according to the invention, suitable in particular for use by the consumer at home,

Fig. 2 shows a diagrammatic cross-section of a second embodiment of a drink dispenser assembly according to the invention, suitable in particular for use in catering establishments,

15 Figs 3, 4 and 5 show, respectively, a longitudinal section, a cross-section and an exploded view of a dispensing head and dispensing line of the drink dispenser assembly according to Fig. 2,

Figs 6a and 6b show a longitudinal section of, respectively, the outlet end of the dispensing line and of the shut-off valve in the closed position,

20 Figs 7a and 7b show a longitudinal section of, respectively, the outlet end of the dispensing line and of the shut-off valve in the flow position,

Figs 8a - 8d show longitudinal sections of a number of alternative embodiments of the shut-off valve according to the invention;

25 Fig. 9 and Fig. 10 show a perspective view and a cross-section of the outlet end of the dispensing line and of the dispensing head of the drink dispenser assembly according to Fig. 1 in, respectively, the disassembled state and the assembled state;

Fig. 11 shows a cross-sectional view of the upper part of a preferred drink dispenser assembly according to the invention; and

30 Fig. 12 and 13 show enlarged details of the dispensing head of Fig. 11 in the closed and open state, respectively.

Figure 1 shows a drink dispenser assembly 1 provided with dispenser device 2 with a chill chamber 3 that can be closed off by means of a cover 4. A pack 5 containing carbonated drink is placed in the chill chamber 3. In the embodiments described below the

carbonated drink is beer that is contained in a flexible bag 6 of the pack 5 under an excess pressure of between 0 and 3 bar, for example 1 to 1.5 bar (the equilibrium pressure of CO₂ above beer). The pack can, however, also contain other carbonated drinks, such as non-alcoholic drinks, under pressures which in general are between 0 and 5 bar excess pressure.

5 The flexible bag 6 is accommodated in an outer, rigid container 7 of the pack 5 and close to a neck is fixed to a flat lip 9 of a filling and dispensing head 10 so as to provide a seal. The filling and dispensing head 10 has an air channel 11 that can be connected to a pressure line 12 in the cover 4, which pressure line is connected to a compressor 13. Instead of a compressor it is also possible to use a different pressure medium, such as a 10 pre-compressed gas, for example compressed air or pressurised CO₂ that is supplied from a separate cylinder. On closing the cover 4, a spring-loaded valve 14 of the filling and dispensing head 10 is moved downwards so that an outlet 15 is exposed and an air channel in the head 10 to the space 16 between the flexible bag 6 and the rigid container 7 is opened, which air channel is in communication with the pressure line 12.

15 A flexible dispensing line 17 is connected to the filling and dispensing head 10 and when the pack 5 is placed in the chill chamber 3 is connected to a dispensing head 18. The dispensing line 17 has a shut-off valve 19 close to an outlet end, which shut-off valve 19 is removably fitted in the dispensing head 18 and is in a normally closed position. When the pack 5 is placed in the dispenser device 2 and the cover 3 is closed, as a result of which the 20 compressor 13 is activated, the shut-off valve 19 is closed and, as a consequence of the pressure built up in the gap 16 by the compressor 13, the beer is driven out of the flexible bag into the flexible line 17, against the shut-off valve 19. By operating a handle 20, the shut-off valve 19, which is an integral part of the dispensing line 17, can be opened and the beer can be tapped from the bag 6. When the pack 5 has been emptied, or if another drink 25 pack is placed in the dispenser device when the pack is still partly full, the container 7 and the flexible dispensing line 17 with the closed shut-off valve 19, which are connected thereto, are removed from the chill chamber 3. The container 7 of the empty pack 5, which, for example, can be made of plastic such as PET or ABS, can be re-used, whilst the flexible bag 6, the filling and dispensing head 10 and the flexible line 17 with the shut-off 30 valve 19 can have been made for once-only use and thrown away or recycled after use. For further details of the drink dispenser device 2 reference is made to International Patent Application PCT/NL 99/00454 in the name of the Applicant, the contents of which are incorporated herein by reference.

Fig. 2 shows an embodiment of a drink dispenser device 25 that is suitable in particular for use in catering establishments. The dispenser device 25 comprises a chill compartment, or refrigerator, 26 with a container 27 containing a carbonated drink therein. The container 27 can comprise a double-walled pack with a rigid outer casing with a flexible bag therein, as shown in Fig. 1, but can also comprise a metal container, such as a stainless steel beer keg known per se. The capacity of the container 27 can vary from a few litres up to 50 litres or more. A compressor or CO₂ cartridge 36 is connected to the container 27. Furthermore, instead of a compressor or CO₂ cartridge, a cartridge containing carbon and CO₂ can be placed in the container 27 to generate the desired pressure, as described in International Patent Application PCT/NL/99/00144. The container 27 is connected via a flexible plastic dispensing line 28 to a dispensing head 29. The dispensing head 29 is part of a beerpull 30 that is fixed to the counter of a bar 31. A shut-off valve 32 according to the present invention is fitted on the outlet end of the flexible line 28, which shut-off valve 32 can be opened and closed by means of handle 33 at the end of the beerpull 30.

A cooling element, that is not indicated in more detail, is accommodated inside the refrigerator 26, which cooling element cools the air in the refrigerator down to, for example, 5 °C - 10 °C. By means of a fan 34, warm air from the hollow beerpull 30 is drawn back into the refrigerator 26. Via a guide tube 35, in which the flexible dispensing line 28 is accommodated and which opens into the dispensing head 29, cold air is fed from the refrigerator 26 through the guide tube 35 over the dispensing line 28 as a result of the vacuum thus produced in the dispensing head 29. The drink is cooled to, for example, 8 °C by this means. The device described above is described in more detail in Netherlands Patent Application no. 1015359 filed on 31 May 2000 in the name of the Applicant and entitled "Tap device and container therefor, as well as method for the production thereof".

Figure 3 shows a longitudinal section of the dispensing head 29 according to Fig. 2. The handle 33 is joined to the housing 43 such that it can rotate about a shaft 40 and engages via a spring 57 and projection 57' on operating element 45 for opening and closing the shut-off valve 32. The free stroke of the handle 33 can be adjusted by positioning projection 57' with respect to the control element 45. In the position shown in Fig. 3 the projection 57' engages directly on the operating element 45, so that the shut-off valve 32 is opened and closed by a small movement of the handle 33. Exchanging the projection 57' for a projection 57' located further to the right compared with the projection in Fig. 3 will

allow the handle 33 to make a greater free stroke before engaging on the operating element 45. By this means, complete opening and closing of shut-off valve 32 can be obtained with a large stroke, such as 90°, of the handle 33. The stroke of the handle 33 can be adjusted between the relatively small stroke (for example 10°) as shown in Fig. 3, and a relatively large stroke, such as 90°, by simply changing the projection 57'.

By means of the spring 57 a certain movement of the handle 33 is possible without this leading to movement of the operating element 45 and the play is eliminated from the rotation of the handle about shaft 40.

An outlet end 41 of the flexible dispensing line 28, which is guided along a curved path by the dispensing head 29, is enclosed in the seat 42 of the dispensing head. The outlet end 41, made of rigid plastic, is provided with a peripheral groove 52 into which a rim 53 of the seat 42 of the dispensing head 29 drops to provide rigid enclosure of the outlet end 41.

The dispensing head 29 comprises a fixed lower section of the housing 43 to which a cover 44 is hingeably joined between a closed position and an open position, in which the outlet end 41 and the shut-off valve 32 of the line 28 can be placed in the dispensing head 29.

The operating element 45 comprises an essentially horizontal arm 46 that is joined by a first end to a pin 48 such that it can pivot. The flexible dispensing line 28 is placed via a guide 49, attached to the top of the operating element 45, in a curved path in contact with a curved end 46' of the operating element 45.

Coupling means of the shut-off valve 32, which, for example, are formed by a flange 51 on a slideable sleeve 61, are connected to a coupling element at the end of the curved end 46' of the arm 46. The coupling element can suitably be constructed as a fork 63 which engages behind the flange 51 of the shut-off valve 32.

Fig. 4 shows the shaft 40 fixed to the handle 33 for moving the operating element 45. The shaft 40 is provided at one end with a spring pawl 47 which has a tooth 38' running at right angles to the shaft 40 at its end. The hingeable cover 44 of the dispensing head 29 has a complementary tooth 38 which engages with the tooth of the spring pawl 47. When the handle 33 is in the upright position, in which the shut-off valve 32 is closed, a releasing cam 39, which likewise is connected to the shaft 40, is positioned such that spring pawl 47 can be depressed, the tooth 38' dropping into the accommodating cavity in the releasing cam 39. This position is shown in Fig. 4, so that when shut-off valve 32 is closed and

handle 33 is in the upright position the cover 44 of the lower section of the housing 43 can be released and is able to hinge open about hinge pin 60.

As can be seen from Fig. 5, the shank 51' of handle 33 is accommodated within a recess in the wall of two concentric annular sleeves 55, 56. By rotation of the sleeve 56 about its axis with respect to the sleeve 55, or by completely omitting sleeve 56, it is possible to adjust the stroke of the handle 33 between, for example, 90° and 10° by, respectively, allowing the openings in the walls of the rings 55, 56 to be in line or moving them into a mutually offset position.

A stop 58 has been formed on the top of the operating element 45, against which stop the shut-off valve 32 comes into contact, on introducing the dispensing line 28 into the dispensing head 29 via the guide tube 35 shown in Fig. 2, and pushing the shut-off valve 32 through too far to beyond the dispensing head 29 is prevented.

Furthermore, Fig. 5 shows a spring element 51" that is connected to the cover 44 in order to move the cover into the upright position on operating the spring pawl 47 and unlocking the cover 44.

It can clearly be seen from Fig. 5 that the end 46' of the operating element 45 is in the shape of a curved saddle that guides the flexible line 28 without kinking or sharp bends from a horizontal into an essentially vertical position, which saddle terminates in a fork 63 into which the flange 51 of the internal sleeve 61 of the shut-off valve 32 can be placed. A separate clamping spring 62 is fitted as a separate component in the seat 42 in order to position the shut-off valve 32 such that it is clamped with respect to the seat 42 when the cover is open, so that the cover 44 can be closed. With this arrangement the rim 53 on the seat 42 and the peripheral groove 52 of the outlet end 41 form a relatively air-tight closure, as a result of which drawing in of air past the outlet end 41 into the cooled beerpull 30 is counteracted.

The closed shut-off valve 32 prevents beer from leaking into the guide tube 35 when introducing and when withdrawing the dispensing line 28, which as a result of its rigidity is able to push the shut-off valve 32 and the outlet end 41 through the guide tube 35. After all, the inner sleeve 61 is placed in its extended position when introducing shut-off valve 32 into the fork 63 or removing it from the fork 63, so that the shut-off valve 32 is closed. As a result of the use of the dispensing head 29 in cooperation with the flexible dispensing hose 28 which is provided with shut-off valve 32 close to the outlet end 41 rapid and easy positioning of the dispensing line 28 can take place so that an empty vessel of carbonated

drink can easily be replaced by a full vessel. Because the entire dispensing line 28 is also replaced during this operation, frequent cleaning of the dispensing line is no longer required, which has the effect of saving a great deal of time and costs, especially when tapping beer.

5 Fig. 6a shows the plastic outlet end 41 of the flexible dispensing hose 28, provided with the shut-off valve 32 according to the present invention. As can be seen from Fig. 6b, the outlet end 41 comprises an external sleeve 70 in which an interior closing projection 71 is accommodated. The closing projection 71 is provided with lateral passageways 72 through which the carbonated drink is able to pass from an upstream channel section 73 of the shut-off valve to a downstream outlet section 74. An internal sleeve 75, to which the flexible dispensing line 28 is welded, is accommodated in the outer sleeve 70 such that it is slideable around the projection 71. The outlet 73' of the inner sleeve 75 has a sealing wall 10 76 with a height corresponding to the height of the projection 71.

In the position shown in Fig. 6b the sealing wall 76 of the outlet 73' of the inner sleeve 75 is in contact with the projection 71 such that a seal is produced. In the shut-off position shown in Fig. 6b openings 77 in the wall of the intermediate sleeve 78, which carries the projection 71, are exposed so that the downstream outlet channel 74 is vented via the openings 77 around the top rim of the outer sleeve 70 (see the arrows indicated diagrammatically) so that a vacuum is not able to build up in the outlet channel 74. When a shut-off valve 32 is closed, such a vacuum gives rise to long-term after-leakage of the carbonated drink from the outlet channel 74, which is undesirable. This is prevented by the vent openings 77 according to the invention. In the position shown, the sealing effect of the sleeve 75 is increased by the pressure of the carbonated drink, which presses the sleeve 75 into the closed position.

25 A sealing cap 80 with a rounded point is fitted on the outlet end 41 to prevent the shut-off valve 32 becoming soiled when inserting the dispensing line 28 into the dispensing head 29 and to achieve smoother guiding of the shut-off valve 32 through the guide tube 35. The protective cap 80 is removed from the outlet end 41 before the outlet end 41 is placed in the seat 42.

30 Figs 7a and 7b show the shut-off valve 32 in its open position, an end face 81 of the internal sleeve 75 being in contact with a bottom face of intermediate sleeve 78. In the position shown, the upstream channel section 73 is in fluid communication with the downstream outlet channel 74 of the shut-off valve 32. Because the front end of the sealing

wall 76 of the internal sleeve 75 is in contact with the intermediate sleeve 78 such that a seal is produced, carbonated drink is prevented from being able to pass to the vent openings 77 when the shut-off valve 32 is in the open position. The height of the sealing wall 76 is sized such that the vent openings 77 are completely shut off at the point in time
5 when part of the wall 76 is still in contact with the projection 71 and therefore no beer is yet able to issue through the outlet 72.

The internal sleeve 75 is provided at its end with a flange 79 that can be accommodated in the fork 63 of the operating element 45. With this arrangement the external sleeve 70 is firmly clamped in the dispensing head via the peripheral groove 52
10 and the play for axial movement of the internal sleeve 75 by means of the flange 79 is provided by the flexible nature of the line 28 which is able to give sufficiently to make a stroke of a few millimetres, such as approximately 4 millimetres, by the internal sleeve 75 possible.

Figs 8a to 8d show various alternatives of the shut-off valve 32 according to the
15 present invention, the same reference numerals as in Figures 6 and 7 being used for identical components.

Fig. 8a shows an embodiment in which the outlet 72 is located in a central constriction in the external sleeve 70. The internal sleeve 75, with the flexible line 28 fixed thereto, is placed inside the external sleeve such that it can be moved and has a sealing
20 projection 71 at its end, which sealing projection 71 can be placed into sealing contact inside the outlet 72 by drawing back the internal sleeve 75.

Fig. 8b shows an embodiment with which the external sleeve 70 is provided with a sealing projection 71 and with an outlet 72, around which projection an outlet 73' in the internal sleeve 75 can be positioned to produce a seal. With this arrangement the wall of
25 the outlet 73' engages, such that a seal is produced, on the projection 71 that is arranged in the external sleeve 70 in a fixed position and the outlet 72 is closed off by a side wall section of the inner sleeve 75.

Fig. 8c shows an embodiment with which a projection 71 is arranged on the inside of the external sleeve 70, around which projection 71 side wall sections of the internal sleeve
30 75 are located which extend beyond the projection 71 in the downstream direction. The front wall sections can be positioned around the projection 71 to produce a seal by drawing back the internal sleeve.

Fig. 8d shows an embodiment which is the mechanical reverse of the embodiment

according to Fig. 8b, sealing projection 71 being arranged on the internal sleeve 75 and a stationary outlet 72, which can be closed off by the projection 71, being made in the external sleeve 70.

5 Embodiments with which the internal sleeve 75 and the external sleeve 70 are provided with inlets and outlets that can be positioned such that they close off one another or in a flow position by turning relative to one another are also possible.

10 Figs 9 and 10 show an embodiment of a dispensing head 90 and dispensing line 101 for use in a dispenser device as shown in Fig. 1. The dispensing head 90 comprises base section 91 with the handle 93 fixed thereto. The base section 91 is provided with a bore 96 and a receptacle tube 92 for receiving a right-angle outlet end 103 of the flexible dispensing line 101. The base section 91 is also provided with a receptacle component 97 for accommodating the flexible dispensing line 101 and the shut-off valve 102 and with a control element or guide 98 that can be slid along the receptacle component 97 in the axial direction and is connected to the handle 93 for operating the shut-off valve 102 of the dispensing line 101. The guide 98 can be constructed in the same way as the fork 63 that is shown in Fig. 5 and engages on the flange 105 of the inner sleeve 107 of the shut-off valve 102 in Fig. 10.

20 The dispensing head 90 is furthermore provided with a top section 95 that is joined to base section 91 such that it can be hinged about a hinge pin 96'. The top section 95 comprises a chamber 99 for accommodating a plate 104 at the end of dispensing line 101. The plate 104 of a dispensing line 101 fitted in the dispensing head 90 is visible via an opening or window 100, so that the contents of the drink dispenser device can be established. The window 100 can have a curved and thus magnifying shape.

25 Fig. 10 shows the assembled dispensing head and the disassembled flexible dispensing line 101 with, at the end, a shut-off valve 102 of the type shown in Figures 6a to 8d. The shut-off valve 102 is connected to the outlet end 103 that is at right angles to the shut-off valve 102 and is fitted in the bore 96 of the dispensing head 90. Furthermore, the plate 104 at the outlet end 103 is provided with visual symbols in order to be able to establish the type of carbonated drink when the plate 104 is fitted in the chamber 99 of the dispensing head. By this means an accurately defined position of the outlet end 106 is guaranteed after the top section 95 has been hinged shut, so that favourable tapping characteristics are obtained.

30 Fig. 11 shows a preferred embodiment of a beverage dispensing system with a

cooling chamber 110 and a beverage container 112 situated within the cooling chamber. In the lid 111 of the cooling chamber an air valve 114 is located which is connected to an air inlet at the top of the container 112. The air valve 114 in the lid 111 is connected to a compressor to provide pressurization of the contents of the container 112 such as beer, which is comprised in a flexible and compressible bag. By introducing air between the wall of the container 112 and the bag, beer can be dispensed from central tube 120 through flexible tube 113 via dispensing valve 115 and out through the outflow nozzle 116. Once the lid 111 is closed, the air valve 114 is connected to the container 112 and closing valve 130 is pressed in a downward direction such that the tube 120 is open and a free flow of pressurized beverage through tube 120 and flexible tube 113 is achieved. In the closed position of the cooling chamber 110, such as shown in Fig. 11, the user can dispense the contents from the container 112 through the outflow nozzle 116 by operating the handle 119. Rotation of handle 119 will cause cam surface 122 connected to the rotational axis of handle 119 to displace carrier 124 against the spring force of biasing spring 125.

Fig. 12 shows the handle 119 and the operating mechanism connected thereto for opening and closing of the valve 115 in detail. Clearly, rotation of the handle 119 to open the valve 115 will first meet resistance from the projection 127 against the cam surface. After overcoming a "dead point", the projection 127 can easily slide along the curved trajectory towards the downward position, so that the handle 119 can be easily placed into the horizontal position as shown in Fig. 13. A firm grip is felt by the user by the force exerted by spring 125. At the end position, shown in Fig. 13, the projection 127 falls into a hollow part 128 of the cam surface such that a firm stop of the tap handle in the open position is achieved. Upon rotation of the handle 119 from the horizontal position shown in Fig. 13 back into the vertical position shown in Fig. 12, the spring force of spring 125 acts to quickly and with relatively little effort flip back the handle 119 and cause a sudden cut-off of beer flow, hence preventing dripping and foaming. The projection 126 on cam 122 will arrest the handle 119 into its properly defined right position.

14a

Any discussion of documents, acts, materials, devices, articles or the like which has been included in the present specification is solely for the purpose of providing a context for the present invention. It is not to be taken as an admission that any or all of these matters form part of the prior art base or were common general knowledge in the field relevant to the present invention as it existed before the priority date of each claim of this application.

Throughout this specification the word "comprise", or variations such as "comprises" or "comprising", will be understood to imply the inclusion of a stated element, integer or step, or group of elements, integers or steps, but not the exclusion of any other element, integer or step, or group of elements, integers or steps.

c:\nrportbl\meldocstmjc\335121_1.doc

THE CLAIMS DEFINING THE INVENTION ARE AS FOLLOWS:

1. A drink dispenser assembly comprising:
5 a dispenser device provided with a dispensing head for accommodating a flexible dispensing line, and a container containing carbonated drink, connected during use to the flexible dispensing line which has a coupling element at an outlet end for connection to the dispensing head, characterised in that the coupling element comprising a shut off valve that, when it is connected to the dispensing head, can be opened and closed via the dispensing head for dispensing the carbonated drink through the valve and which shut-off valve can be closed while placing the outlet end of the dispensing line into the dispensing head and respectively, removing the outlet end of the dispensing line from the dispensing head, the shut off valve comprising a first sleeve and a second sleeve, which is concentric with respect to the first sleeve, which first sleeve is provided with an inlet to an upstream part of the dispensing line and an outlet, the second sleeve being provided with an inlet which interacts with the outlet of the first sleeve and with an outlet, coupling means being arranged on one of the sleeves which can be moved by the coupling means between a flow position, in which the outlet of the first sleeve is in fluid communication with the inlet of the second sleeve, and a shut-off position in which the outlet of the first sleeve is closed off by the second sleeve.
10
15
20
2. The drink dispenser assembly according to claim 1, characterized in that the dispensing line is at least partially flexible.
25
3. The drink dispenser assembly according to claim 1 or 2, wherein the dispensing head is provided with a knob or handle, characterised in that the dispensing head has an operating element which is connected to the knob or handle and by means of which the shut-off valve can be detachably connected, for opening and closing the shut-off valve by moving the knob or handle.
30
4. The drink dispenser assembly according to claim 1, characterised in that the shut-off valve is provided with coupling means for detachable connection to the operating element.
35

c:\nrportbl\meidocsvmjcl335121_1.doc

5. The drink dispenser assembly according to claim 1, characterised in that one of the sleeves has an interior projection, the sleeves being movable by the operating element with respect to one another in order to bring the projection into sealing engagement on the inlet or outlet of the other sleeve.
- 5
6. The drink dispenser assembly according to claim 1 or 5, characterised in that the coupling means comprise a flange or a peripheral groove, the operating element comprising an accommodating component that is connected to the knob or handle and can be moved in the axial direction of the sleeves, for engagement on the flange or on the peripheral groove.
- 10
7. The drink dispenser assembly according to claim 6, characterized in that the accommodating component has an open cavity on one side in which the inner or the outer sleeve can be enclosed.
- 15
8. The drink dispenser assembly according to any one of claims 4 to 7, with reference to claim 3, characterized in that the dispensing head has a base section, that is connected to the knob or handle and to the operating element, and a second section provided with an accommodating cavity, which second section is movably connected to the base section, between an open position, in which the operating element is released to connect the shut-off valve to the operating element, and a closed position, in which the shut-off valve is at least partially located within the accommodating cavity of the second section.
- 20
9. The drink dispenser assembly according to claim 8, characterized in that the dispensing head is provided with locking means which are able to release the second section only when the shut-off valve has been placed in a closed position.
- 25
10. The drink dispenser assembly according to claim 8 or 9, characterised in that the second section can be moved about a hinge pin that is located transversely to the longitudinal direction of the dispensing line, or parallel thereto.
- 30
11. The drink dispenser assembly according to any one of the preceding claims, characterised in that the dispensing line is provided with an outlet section located downstream of the shut-off valve.
- 35

c:\nrportbl\mldocs\mjcl335121_1.doc

12. The drink dispenser assembly according to any one of the preceding claims, characterised in that the outlet section is at right angles to the dispensing line.
- 5 13. The drink dispenser assembly according to claim 11 or 12, characterized in that the outlet end is provided with an external peripheral groove or ridge that can be connected to a complementary ridge or cavity on/in the interior of an outlet of the dispensing head.
- 10 14. The drink dispenser assembly according to any one of the preceding claims, characterised in that the outlet end of the dispensing line is provided with a plate, the dispensing head being provided with a chamber for accommodating the plate and with a window, located parallel to the plate, for displaying at least part of the plate.
- 15 15. The drink dispenser assembly according to any one of the preceding claims, characterised in that the operating element comprises a guide with an essentially horizontal arm, a first end of which can be moved about a pivot pin , a curved arm having a fork at one end for coupling to the shut-off valve being located at a
20 second end of the arm, which end is located some distance away from the pivot pin, and transversely thereto.
16. The drink dispenser assembly according to claim 15, characterized in that the operating element comprises a positioning element beneath which the
25 dispensing line can be fitted for guiding the dispensing line along the curved arm.
17. The drink dispenser assembly according to any one of the preceding claims, characterised in that the dispenser device is provided with pressure means, which can be connected to the container, for feeding a pressure medium to the
30 container, and with cooling means for cooling a container placed in the compartment.
18. The drink dispenser assembly according to any one of the preceding claims,
35 characterised in that the shut-off valve is provided with a vent which is in fluid

c:\nrportbl\meldocs\mjcl335121_1.doc

communication with an outlet of the shut-off valve when the shut-off valve is in the closed position.

- 5 19. The drink dispenser assembly according to claim 1 or 2, characterized in that the shut-off valve is electromagnetic, the dispensing head being provided with an electromagnetic operating element.
- 10 20. A container provided with a carbonated drink, having a flexible dispensing line which is connected to or can be connected to the container and has a coupling element close to one end for connection to a dispensing head of a drink dispensing device, characterised in that the coupling element comprises a shut-off valve that, when it is connected to the dispensing head, can be opened and closed via the dispensing head for dispensing the carbonated drink through the valve and which shut-off valve can be closed while placing the end of the dispensing line into the dispensing head and, respectively, removing the end of the dispensing line from the dispensing head, the shut off valve comprising a first sleeve and a second sleeve, which is concentric with respect to the first sleeve, which first sleeve is provided with an inlet to an upstream part of the dispensing line and an outlet, the second sleeve being provided with an inlet which interacts with the outlet of the first sleeve and with an outlet, coupling means being arranged on one of the sleeves which can be moved by the coupling means between a flow position, in which the outlet of the first sleeve is in fluid communication with the inlet of the second sleeve, and a shut-off position in which the outlet of the first sleeve is closed off by the second sleeve.
- 25 21. The container according to claim 20, provided with a relatively rigid outer jacket and an interior flexible bag containing the carbonated drink, which bag is connected to a first shut-off element that comprises a connecting element that is connected to the dispensing line that is at least partially of flexible construction.
- 30 22. The container according to claim 21, wherein the outer jacket is provided with a connection opening for connection to pressure means for feeding a pressure medium to the space between the flexible bag and the outer jacket.
- 35 23. The container according to claim 20, characterised in that the coupling means comprise a flange or a peripheral groove for engagement on an operating

c:\nrportbl\meldocs\mjcl\335121_1.doc

element of the drink dispenser device that comprises an accommodating component that is connected to a knob or handle and can be moved in the axial direction of the sleeves, for engagement on the flange or on the peripheral groove.

5

24. The container according to one of claims 20 to 23, characterised in that the shut-off valve is provided with a vent which is in fluid communication with an outlet of the shut-off valve when the shut-off valve is in the closed position.

10

25. The container according to one of claims 20 to 24, characterised in that the shut-off valve is electromagnetic, the dispensing head being provided with an electromagnetic operating element.

15

26. The container according to claim 20, characterised in that the coupling means comprise a flange or a peripheral groove on one of the sleeves.

27. The container according to one of claims 20 to 26, characterised in that the dispensing line is provided at the outlet end with a relatively rigid tube section with the shut-off valve connected thereto.

20

28. The container according to claim 27, with reference to claim 24 or 25, characterised in that the tube section forms the outer sleeve of the shut-off valve.

25

29. The container according to claim 27 or 28, characterised in that the tube section is provided with a ridge or groove on an outer surface.

30. The container according to claim 27, 28 or 29, characterised in that a plate is attached to the outlet end of the dispensing line.

30

Fig 1

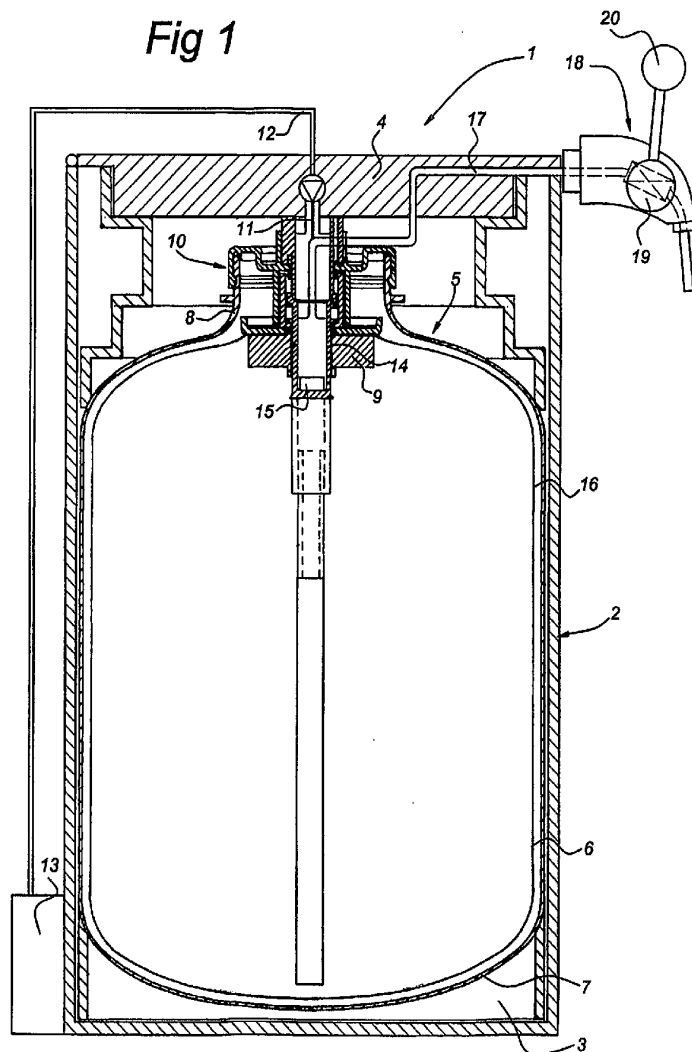

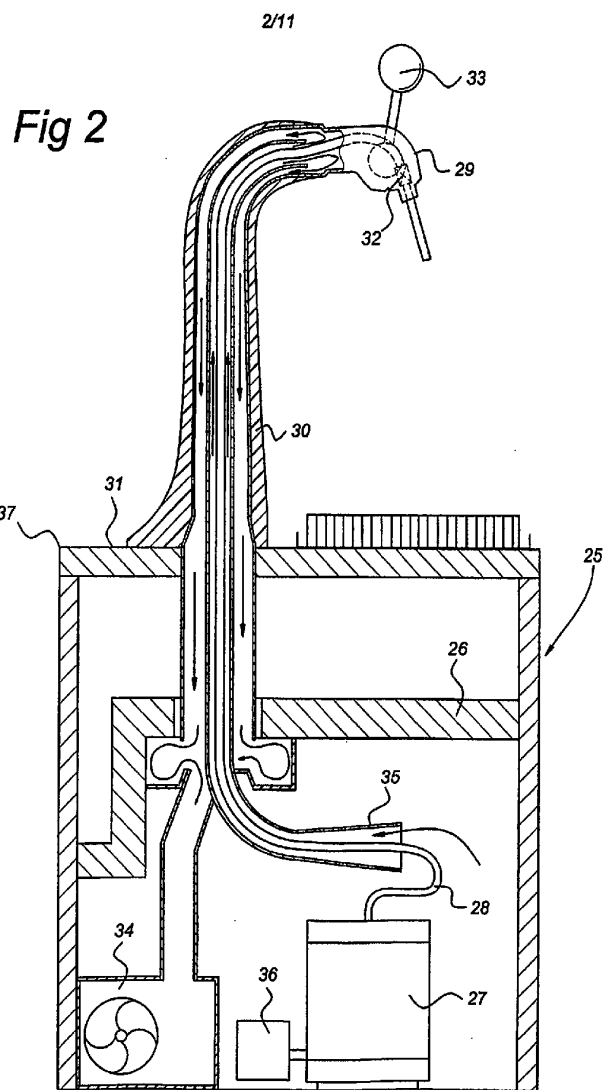

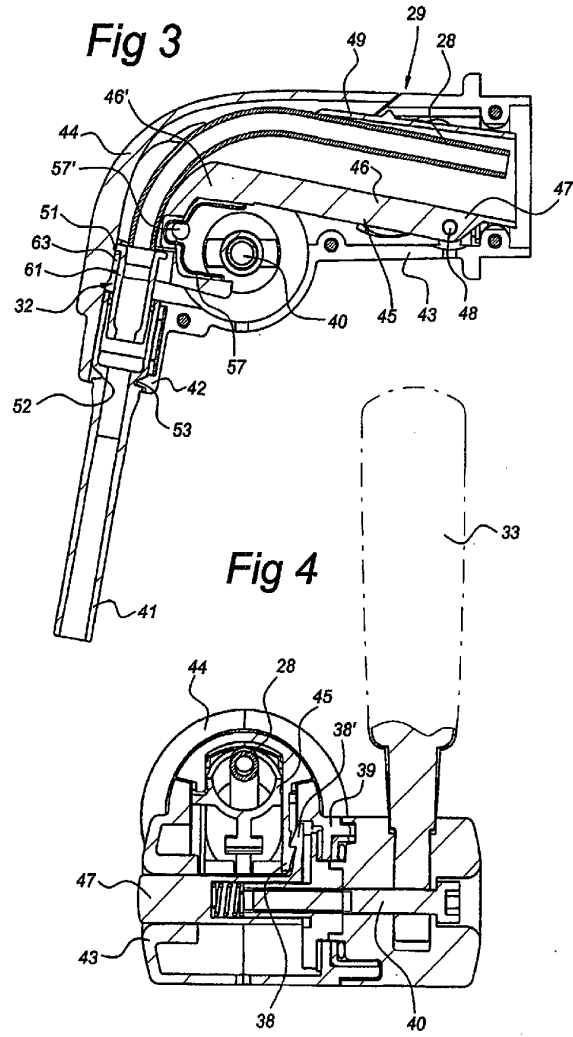
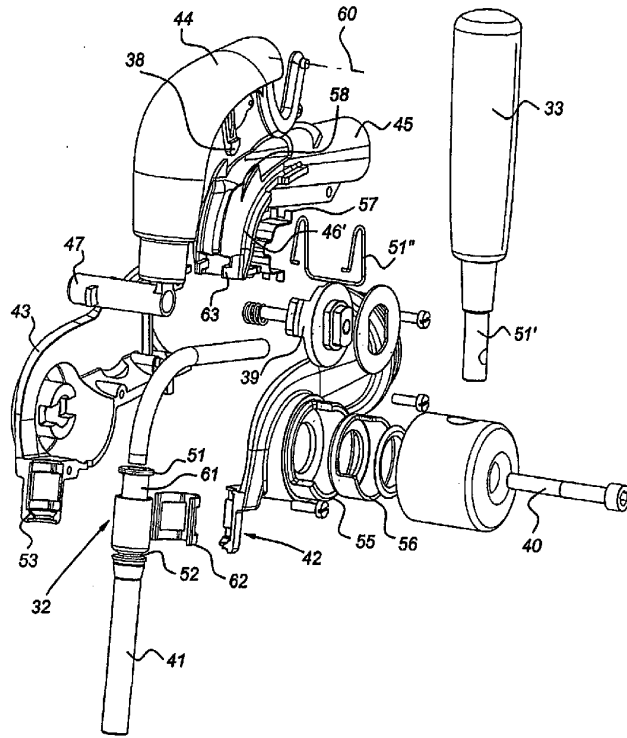

Fig 5



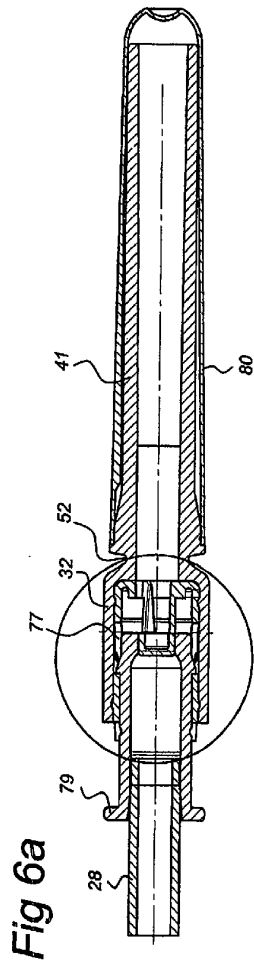

Fig 6a

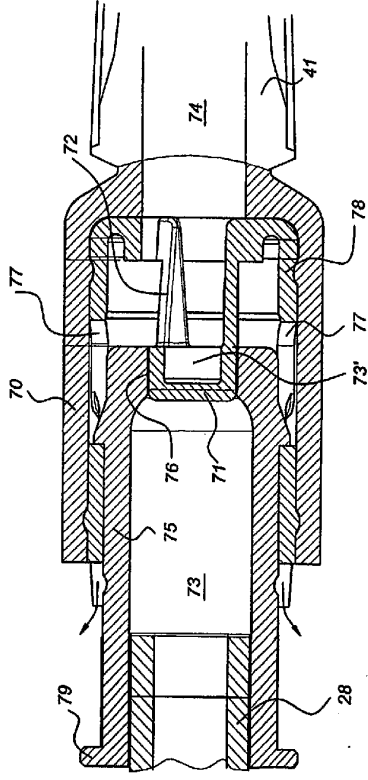
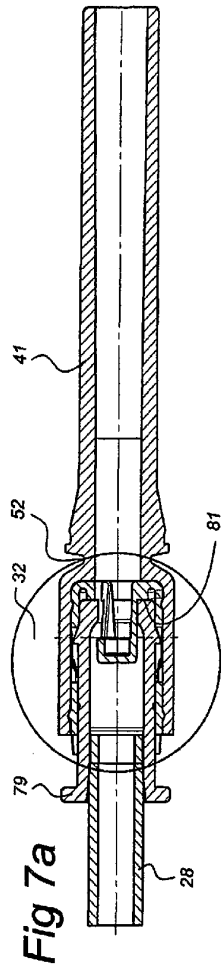
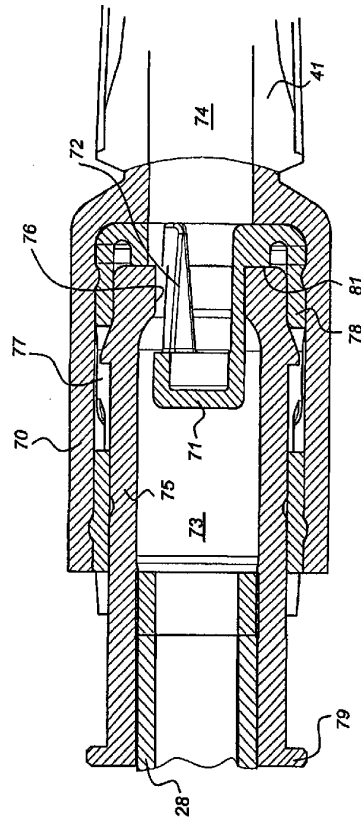

Fig 6b



6/11



7/11

Fig 8a

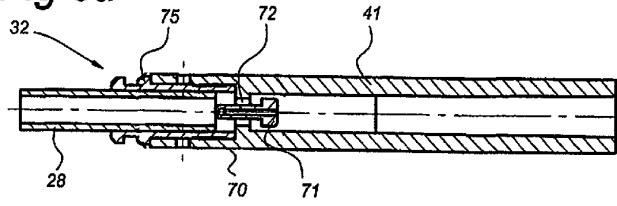

Fig 8b

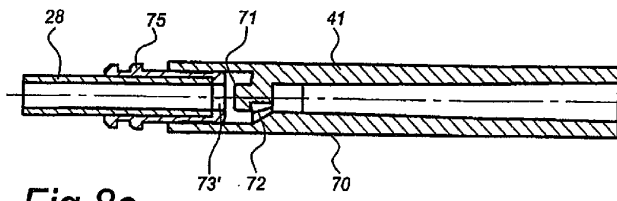

Fig 8c

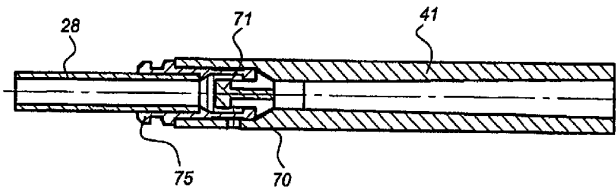

Fig 8d

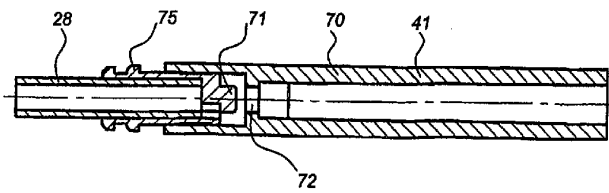

Fig 9

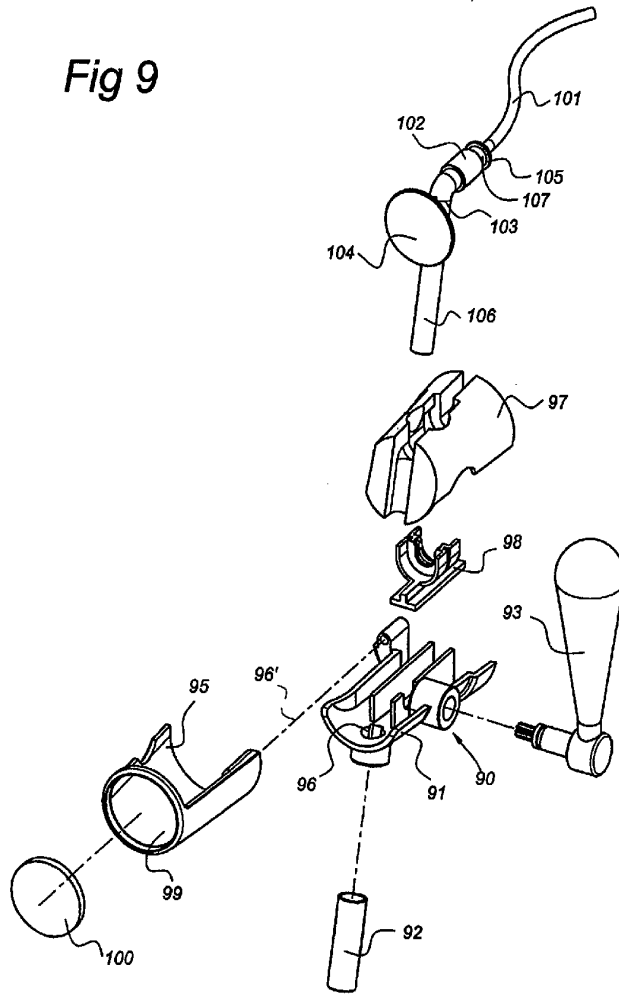

Fig 10

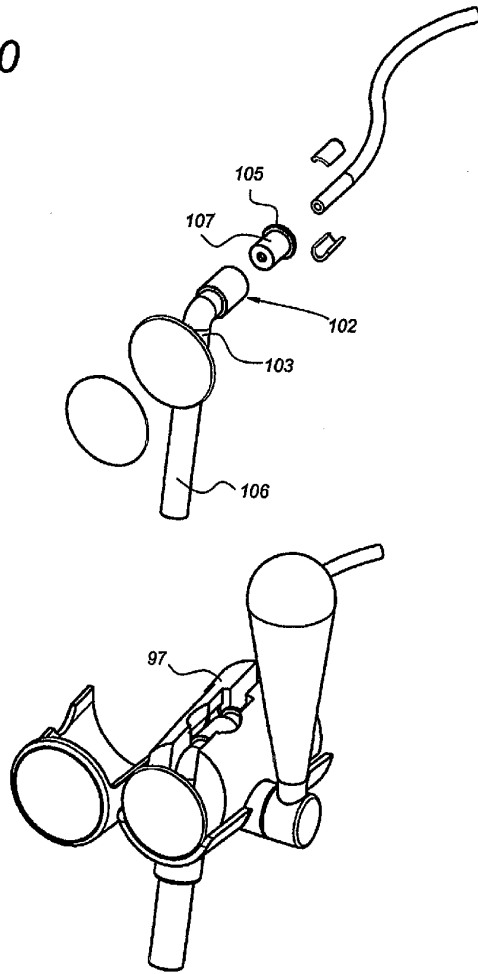
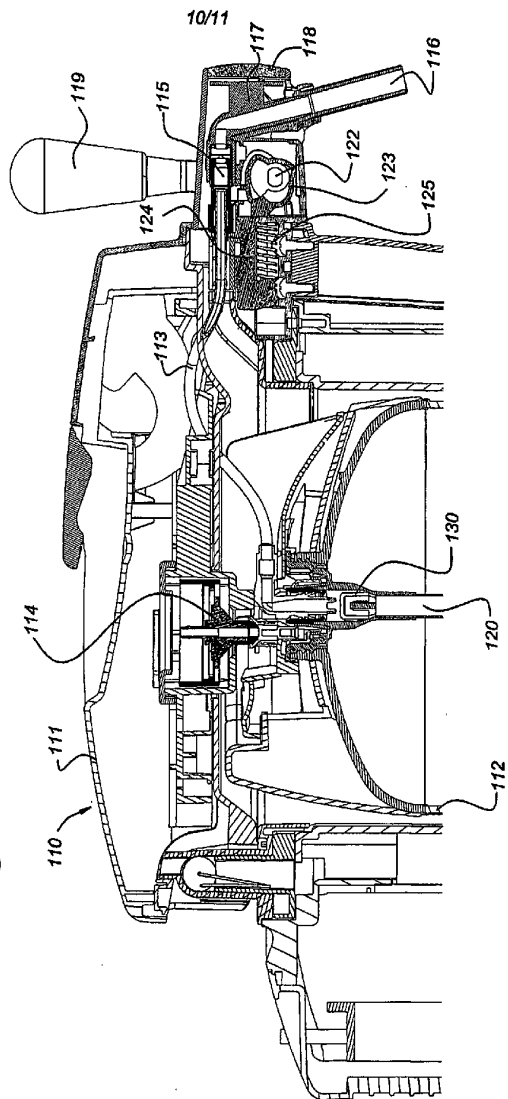

Fig 11



11/11

Fig 12

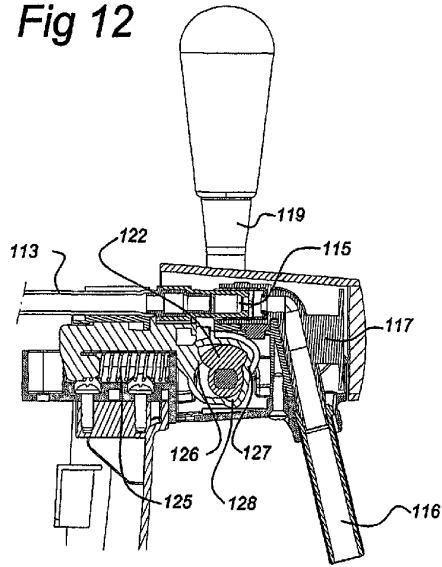

Fig 13

