

(No Model.)

4 Sheets—Sheet 1.

C. M. SNELL.

HAT BLOCKING AND BAND CUTTING MACHINE.

No. 526,269.

Patented Sept. 18, 1894.

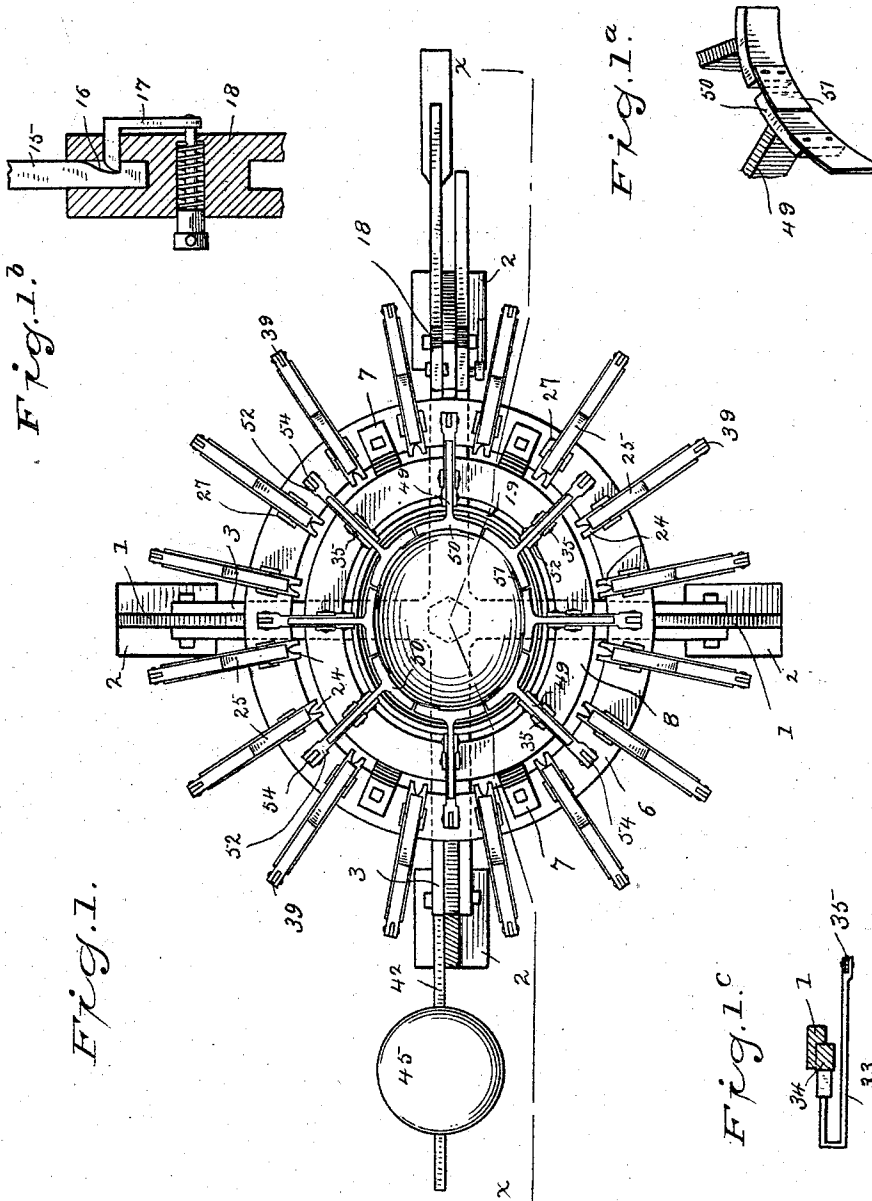

Fig. 1.b

Fig. 1.a

Fig. 1.

Fig. 1.c

WITNESSES

H. A. Lamb,
E. V. Richardson.

INVENTOR

Charles M. Snell
By A. M. Wooster
Atty.

(No Model.)

4 Sheets—Sheet 2.

C. M. SNELL.

HAT BLOCKING AND BAND CUTTING MACHINE.

No. 526,269.

Patented Sept. 18, 1894.

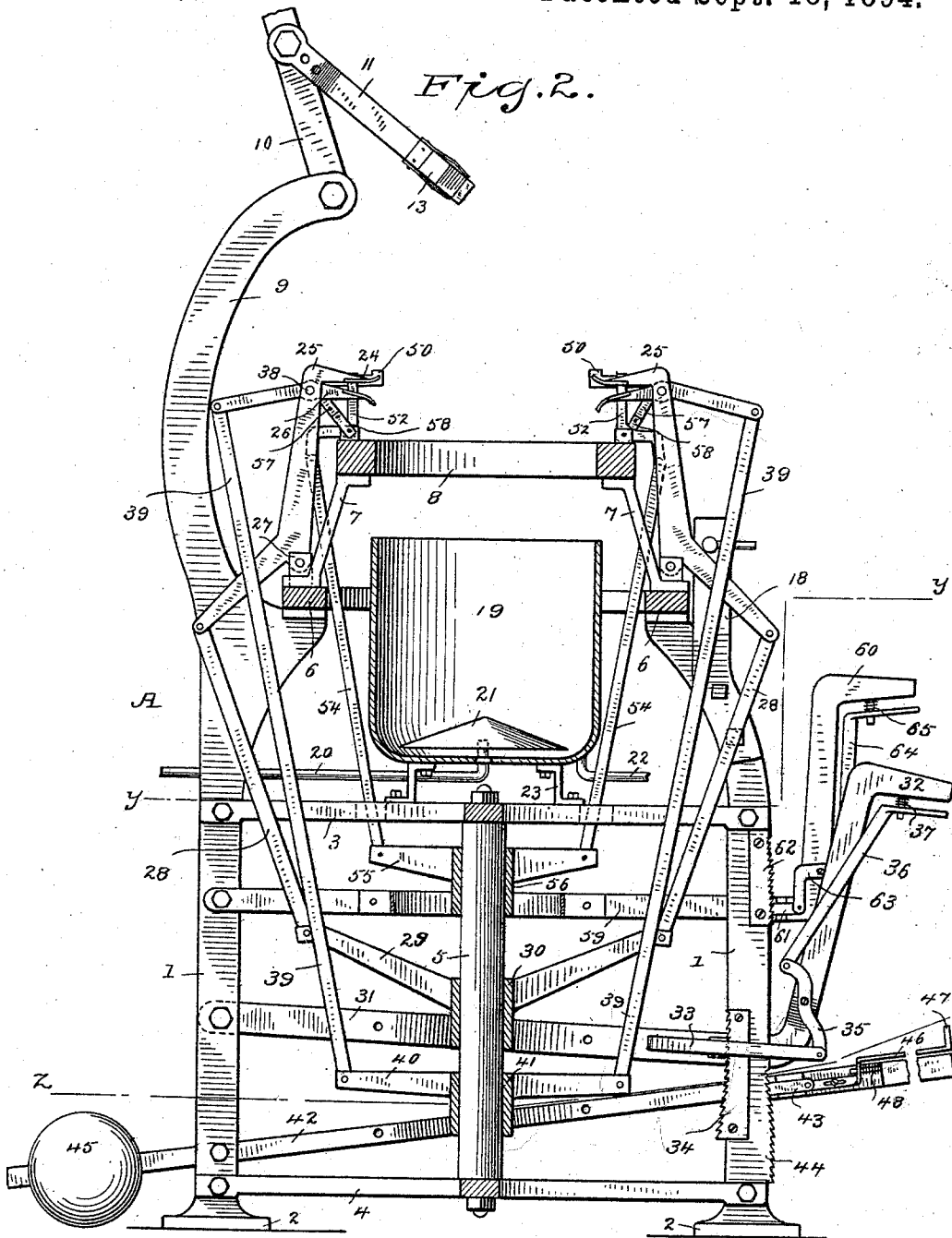

WITNESSES

H. A. Lamb
Susie V. Richardson.

INVENTOR

Charles M. Snell
By
A. M. Wooster
Atty.

(No Model.)

4 Sheets—Sheet 3.

C. M. SNELL.

HAT BLOCKING AND BAND CUTTING MACHINE.

No. 526,269.

Patented Sept. 18, 1894.

Fig. 3.

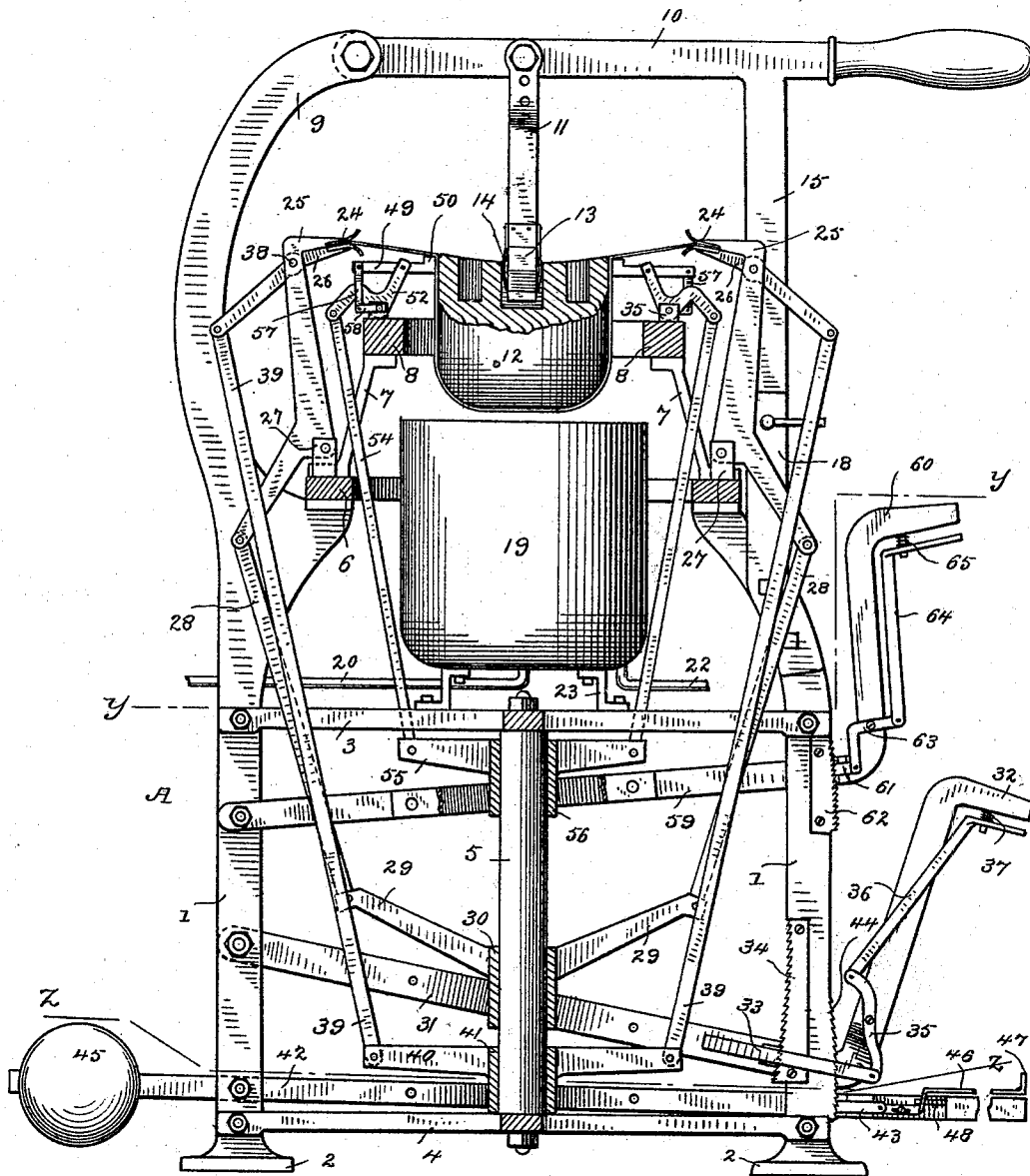

WITNESSES

H. A. Lamb
Suzie T. Richardson

INVENTOR

Charles M. Snell
By *A. M. Wooster*
Atty.

(No Model.)

4 Sheets—Sheet 4.

C. M. SNELL.

HAT BLOCKING AND BAND CUTTING MACHINE.

No. 526,269.

Patented Sept. 18, 1894.

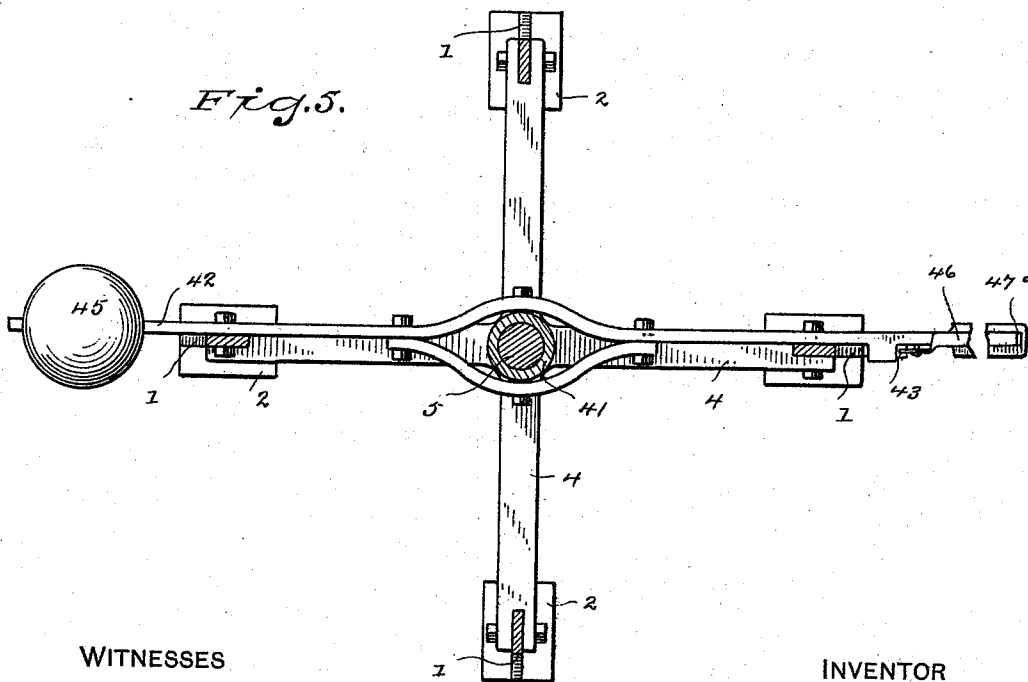
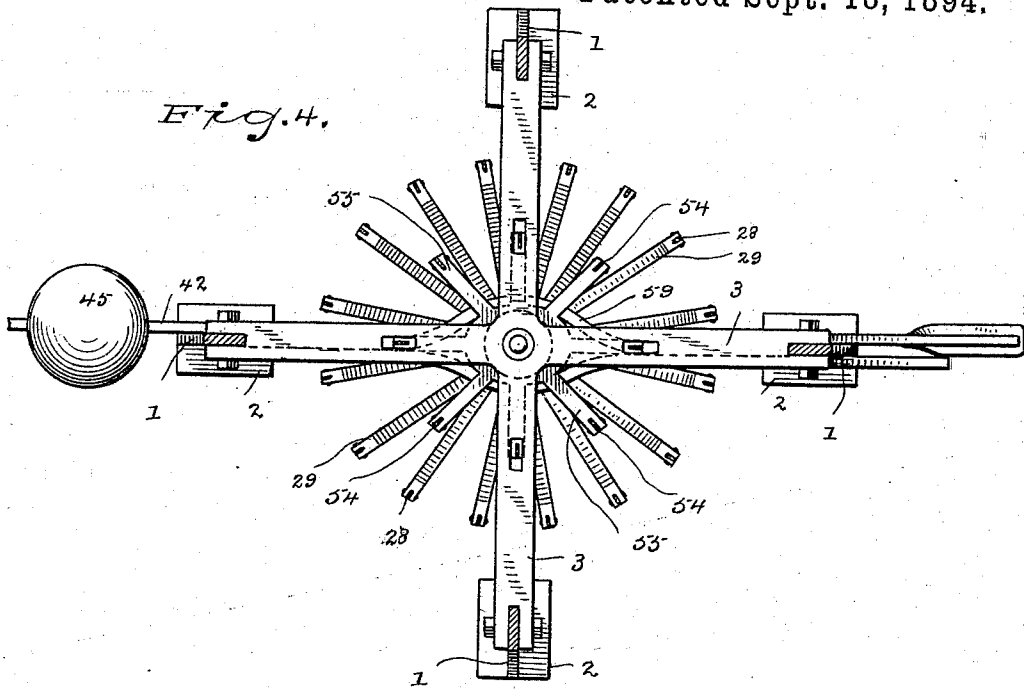

WITNESSES

H. F. Lamb
Sime V. Richardson

INVENTOR

Charles M. Snell
By *A. M. Wooster*
Att'y.

UNITED STATES PATENT OFFICE.

CHARLES M. SNELL, OF DANBURY, CONNECTICUT, ASSIGNOR OF ONE-HALF
TO ERNEST E. HODSHON, OF SAME PLACE.

HAT-BLOCKING AND BAND-CUTTING MACHINE.

SPECIFICATION forming part of Letters Patent No. 526,269, dated September 18, 1894.

Application filed December 26, 1893. Serial No. 494,624. (No model.)

To all whom it may concern:

Be it known that I, CHARLES M. SNELL, a citizen of the United States, residing at Danbury, in the county of Fairfield and State of Connecticut, have invented certain new and useful Improvements in Hat-Blocking and Band-Cutting Machines; and I do hereby declare the following to be a full, clear, and exact description of the invention, such as will enable others skilled in the art to which it appertains to make and use the same.

My invention relates to the class of machines used in the art of hat manufacturing which block the hat bodies, stretch the brims, and at the same time perform the operation which is known as cutting the bands, and has for its object to simplify and cheapen the construction of this class of machines and at the same time to greatly improve their capacity and mode of operation in use.

With these ends in view I have devised the novel construction of which the following description in connection with the accompanying drawings is a specification, numbers being used to designate the several parts.

Figure 1 is a plan view of the entire machine the hat block and hand lever being removed; Fig. 1^a, an enlarged detail view illustrating the construction of the band cutters; Fig. 1^b, an enlarged detail view illustrating the construction of a latch which may be used to lock the carrying lever and block in the blocking position; Fig. 1^c, an enlarged detail view illustrating the construction of the latch which locks the operating lever for the grippers in operative position; Fig. 2, a vertical section on the line *x x* in Fig. 1, the sliding sleeves, operating levers and opposite grippers, band cutters, links, &c., being in elevation; the full number of these parts being omitted from the drawings for the sake of clearness in illustration, the hand lever being raised, the block removed and the parts in position ready to receive the hat body; Fig. 3, a similar view the parts being shown in operative position, that is to say, the body having been firmly gripped and stretched, the block having been forced into it and the band cutters moved into position to cut the band; Fig. 4, a horizontal section on the line *y y* in

Figs. 2 and 3 looking down, and Fig. 5 is a horizontal section on the line *z z* in Figs. 2 and 3 looking down.

A denotes the frame of the machine as a whole. The special shape of the framework is of course not of the essence of my invention. I preferably employ four uprights designated by 1 which are provided with base-pieces 2 upon which the machine rests. These uprights are connected by upper and lower castings denoted respectively by 3 and 4. These castings consist of a center and arms extending outward therefrom at right angles to each other. The centers support a vertical standard or post 5. The uprights extend above upper castings 3 and support a circular plate 6 the purpose of which will presently be fully explained. 7 denotes braces which extend upward and inward from plate 6 and support another circular plate 8. One of the uprights is provided with an upwardly extending arm 9 to which the hand lever 10 is pivoted.

11 denotes a link pivoted to hand lever 10 which carries the hat block 12. The lower end of this link is provided with outwardly bowed springs 13 which engage the walls of the usual central opening 14 in the block thereby attaching the block to the link in a simple and convenient manner which retains the block in position but permits its ready removal from the link.

15 is an arm which depends from hand lever 10 and is provided at its lower end with a locking notch 16, see Fig. 1^b, which is adapted to be engaged by a spring latch 17 socketed in an arm 18 which extends upward from the upright opposite to the one which is provided with upwardly extending arm 9 to which the hand lever is pivoted, see Fig. 1^b in connection with Fig. 2.

19 denotes a steam box into which steam is admitted by a pipe 20, over the end of which is a deflector 21 which throws the steam outward to the wall of the steam box causing it to rise up on the sides of the hat body instead of rising up against the crown of the hat body.

22 is a drip pipe by which the water of condensation passes from the steam box. This

steam box is shown as lying within plate 6 and as resting upon braces 23 which are bolted to upper casting 3. In use the edge of the hat body to be operated upon is placed between the upper and lower gripping plates 24 carried by the upper and lower gripping arms 25 and 26. The exact shape of the gripping arms and of the various other details of construction is of course not of the essence of my invention. I preferably however, adopt general outlines of construction substantially as illustrated in the drawings. It is deemed sufficient for the purposes of this specification to say that the upper gripping arms denoted by 25 extend downward and then outward and are pivoted at approximately their mid-length to ears 27 on circular plate 6. At the lower ends of these levers links 28 are pivoted, the other ends of said links being pivoted to arms 29 extending outward from a sleeve 30 which is adapted to slide on standard 5. The movement of this sleeve is controlled by an operating lever 31 which is pivoted to one of the uprights and extends across the machine and is curved upward and outward, the outer end forming a hand piece 32 for convenience in operation. 33, see Fig. 1^c in connection with Fig. 2, is a latch which engages a rack 34 to lock lever 31 in operative position. This latch is manipulated by means of a lever 35 and rod 36. A spring 37 engaging the rod acts to retain the latch in its normal or engaging position, that is as shown in Fig. 3. To operate this lever the operator presses it down by hand, the latch and rack being so constructed that the latch will slide over the rack during the downward movement. The opposite movement is performed by withdrawing the latch from engagement with the rack by manipulating rod 36 by hand against the power of the spring and then raising the lever sufficiently to move the gripping arms and gripping plates inward as far as may be required. The lower gripping arms denoted by 26 are pivoted to the upper gripping arms as at 38 and extend upward therefrom. At the outer ends of the lower gripping arms links 39 are pivoted, the other ends of said links being pivoted to arms 40 extending outward from a sleeve 41 which is adapted to slide on standard 5. The movement of this sleeve is controlled by an operating lever 42 which is pivoted to one of the uprights and extends across the machine and outward therefrom the outer end of said lever being provided with a spring actuated latch 43 which engages a rack 44 to retain said lever and the parts controlled thereby in operative position. This lever extends outward on the side at which it is pivoted also and is provided with a weight 45 the action of which is to carry that end of the lever downward and consequently to throw the other end upward when it is not locked at its lowered position by the latch. Latch 43 is provided with a controlling rod 46 the outer end of which is bent upward at

an angle to form a heel piece as at 47 and is adapted to be engaged by the heel of the operator and forced backward against the power of a spring 48. To operate this lever the operator simply places his foot upon it, the latch and rack being so constructed that the latch will slide over the rack during the downward movement, sufficient pressure being of course exerted to overcome the power of the weight. The opposite movement is performed by withdrawing the latch, ordinarily by the heel, against the power of the spring and allowing the weight to tilt that end of the lever upward as in Fig. 2.

I will now describe the operation of this portion of the machine. When not in use hand lever 10 is thrown backward out of the way and the hat block ordinarily removed, as indicated in Fig. 2, in which view the parts are shown in position to receive a hat body. When a body is inserted the edge of the brim is placed between the gripping plates the crown being downward. The operator then presses down upon lever 42 thereby drawing down sleeve 41 and links 39 the action of which is to move the gripping plates upon the lower gripping arms upward so that the hat brim is clamped firmly between the upper and lower gripping plates, the operating lever being locked in any position in which it is placed by the engagement of latch 43 with rack 44. While the hat is held in this position it is softened by steam which rises up around it from the steam box as already described. The operator then presses down lever 31 thereby moving down sleeves 30 and arms 29 the action of which is to draw down links 28 and to swing lower gripping arms 25 on the pivots by which they are secured to ears 27. The effect of this movement is to move all the sets of gripping arms and gripping plates outward radially thereby stretching the brim of the hat body. The parts are locked in this position by the engagement of latch 33 with rack 34. It will of course be apparent that the gripping arms, links, &c., must be so proportioned relatively to each other, and so pivoted that the oscillation of gripping arms 25 on their pivots, as in stretching a brim, will have no effect whatever upon the position of the gripping plates relatively to each other. The gripping action of the plates upon the brim is in fact controlled entirely by links 39 and operating lever 42 without regard to whether the gripping arms are swung inward or outward. When therefore the gripping plates have once gripped a brim they retain it until it is released by movement of lever 42, so that no matter how hard the brim is stretched by oscillating the gripping arms outward there is no danger that the hold upon the brim will be loosened.

Having stretched the brim in the manner described a hat block or the required shape and size is placed upon link 11 and is then forced down into the body by means of the hand lever, thereby stretching the crown of

the body as well as the brim, the action being as a matter of fact to stretch all portions of the crown and brim evenly, the body being kept continually soft by steam from the steam box. The body is now ready for the operation known in the art as cutting the band which is accomplished in the manner which I will now describe. 49 denotes a series of radial arms having at their outer ends curved blocks 50, each block being provided at one end with a spring plate 51 which partially overlaps the next block thereby closing the spaces between the blocks as they move outward radially, as will be clearly understood from Fig. 1^a in connection with Fig. 1. Arms 49 are moved in and out by means of levers 52 which are pivoted in ears 53 upon upper circular plate 8. These levers are preferably made substantially the shape shown in the drawings which may be described as a double bell crank lever. The inner ends of these levers are pivoted to arms 49 and their outer ends are pivoted to links 54, the lower ends of said links being pivoted to arms 55 extending outward radially from a sleeve 56 which is adapted to slide on standard 5. The pivotal point of levers 52 to arms 49 is about the mid-length of said arms. See Fig. 3. These arms are maintained in a horizontal position during their backward and forward movements by means of vertical links 57 and horizontal links 58. The upper ends of the vertical links are pivoted to the outer ends of arms 49, and the lower ends of said links are pivoted to the outer ends of the horizontal links, the inner ends of the horizontal links being pivoted concentrically with levers 52, preferably upon the same pivot. Sleeve 56 is operated to move arms 49 in or out as may be required by means of an operating lever 59 which is pivoted to one of the uprights and extends across the machine, then upward and outward the end thereof forming a hand piece 60 for convenience in operation. It will be readily understood from Figs. 2 and 3 that the upward movement of lever 59 and sleeve 56 will move blocks 50 and spring plates 51 inward to their operative position (Fig. 3) and that the downward movement of said lever and sleeve will move said blocks and spring plates outward out of operative position. Operating lever 59 and sleeve 56 are locked at their raised that is their operative position by means of a latch 61 carried by lever 59 which engages a rack 62 on one of the uprights. This latch is moved in or out of operative position by means of a bell crank lever 63 one arm of which is pivoted to the rear end of the latch and to the other end of which is pivoted an operating rod 64. A spring 65 acts to retain the latch in its engaging *i. e.* its operative position. It will be seen that when operating lever 59 is moved upward to its operative position the latch will slide over the teeth of the rack and will be locked at the raised position. The opposite movement is performed by withdrawing the latch from engagement with the rack by manipulating rod 64 by hand against

the power of the spring and then moving the lever downward sufficiently to move blocks 50 and spring plates 51, *i. e.*, the band cutters, outward out of operative position. The three operating levers 31, 42 and 59 are bifurcated at their mid-length, see Figs. 4 and 5 in connection with Fig. 3, so as to inclose the sleeves to which they are respectively pivoted thereby insuring perfect evenness of movement in use. In use after the band cutters have been set up to place and locked there in the manner just described the block may be pushed down farther into the crown of the body if thought best, or where depending arm 15 and spring latch 17 are used the hand lever may be pressed down until the latch engages the arm as clearly shown in Fig. 1^b. This may be accomplished by the first downward movement of the hand lever forcing the block into the crown of the body or by a second movement after the band cutters have been set to place as preferred. After the body has been blocked and the band cut the operator in order to remove the blocked body, first moves the band cutters backward out of operative position by manipulating lever 59. He then releases the hold of the gripping plates upon the brim by manipulating lever 42 and finally moves the gripping plates and gripping arms backward out of the way by manipulating lever 31. The parts will now be in the position shown in Fig. 2, that is ready to receive another hat body for blocking.

Having thus described my invention, I claim—

1. The combination with suitable framework, gripping arms 25 pivoted thereto and gripping arms 26 pivoted to arms 25, of a sliding sleeve 41 having radial arms and links pivoted to said arms and to arms 26, whereby said arms in connection with arms 25 are caused to grip or release a hat brim and a sliding sleeve 30 having radial arms and links 28 pivoted to said arms and to arms 25, whereby said arms are oscillated carrying arms 26 with them, whereby a hat brim may be stretched while gripped by the arms.

2. The combination with gripping arms 25 and 26 operating as described, of sleeves 41 and 30, links 39 and 28 and operating levers 42 and 31, whereby the gripping arms may be caused to grip a brim and then swung outward to stretch the brim.

3. The combination with suitable framework, arms 25 pivoted thereto and arms 26 pivoted to arms 25, of sleeve 41 having radial arms and links pivoted to said arms and to arms 26, lever 42 pivoted to the framework, bifurcated to inclose the sleeve which is pivoted thereto, and provided at its rear end with a spring latch having a heel piece, a rack adapted to be engaged by the latch and a weight on said lever forward of its pivotal point so that when the operator releases the latch the weight will tilt the lever and throw the gripping arms to the open position and when the operator presses down upon the le-

ver the gripping arms are moved to the gripping position and locked there by engagement of the latch with the rack.

4. The combination with suitable framework, arms 25 pivoted thereto and arms 26 pivoted to arms 25, of sleeve 30 having radial arms and links pivoted to said arms and to arms 25, lever 31 pivoted to the framework, bifurcated to inclose the sleeve and provided with a hand piece 32, spring latch 33 adapted to engage a rack to lock the parts in operative position, lever 35 and rod 36, whereby the latch is operated and a spring 37 which acts to retain the latch in the locking position.

5. The combination with band cutters consisting of radial arms having blocks at their forward ends and spring plates overlapping said blocks, of levers 52 pivoted to the framework and to the radial arms, suitable means for oscillating said levers to move the radial arms in or out and links 57 and 58 by which said arms are caused to move horizontally.

6. The combination with radial arms 49 and the band cutters carried thereby, of levers 52 by which arms 49 are operated, horizontal links 58 pivoted concentrically with said levers, vertical links 57 pivoted to links 58 and to arms 49 by which said arms are caused to move horizontally, and sleeve 56 and links 54 by which said levers are oscillated.

7. The combination with radial arms 49 and the band cutters carried thereby, of levers 52 by which arms 49 are operated, operating le-

ver 59 to which the sleeve is pivoted and which is provided with a hand piece 60, a latch 61 adapted to engage a rack to lock the parts in operative position, bell crank lever 63 and rod 64 by which the latch is operated and a spring 65 acting to hold the latch in operative position.

8. The combination with suitable framework gripping arms 25 pivoted thereto, gripping arms 26 pivoted to arms 25, radially moving band cutters and levers 52 by which they are reciprocated, of a vertically movable sleeve 41 and intermediate connections whereby arms 26 may be operated to grip or release a hat brim and vertically movable sleeve 30 and intermediate connections whereby arms 25 may be oscillated to stretch the brim and a vertically movable sleeve 56 and intermediate connections whereby the band cutters may be reciprocated as and for the purpose set forth.

9. The combination with suitable framework and standard 5, of the radially movable band cutters, levers 52 by which they are operated, sleeve 56 adapted to slide on the standard and links 54 which connect levers 52 to the sleeve.

In testimony whereof I affix my signature in presence of two witnesses.

CHARLES M. SNELL.

Witnesses:

A. M. WOOSTER,

SUSIE V. RICHARDSON.