

June 8, 1937.

E. LOWY

2,083,029

HANDBAG

Filed April 15, 1937

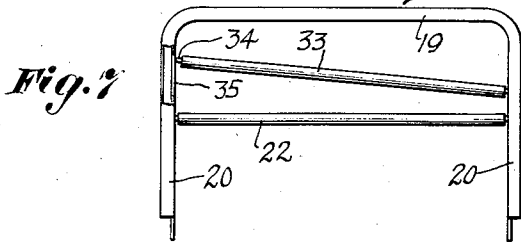
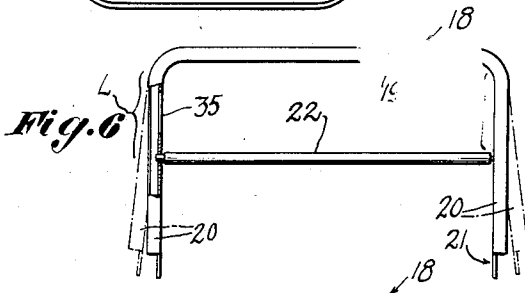
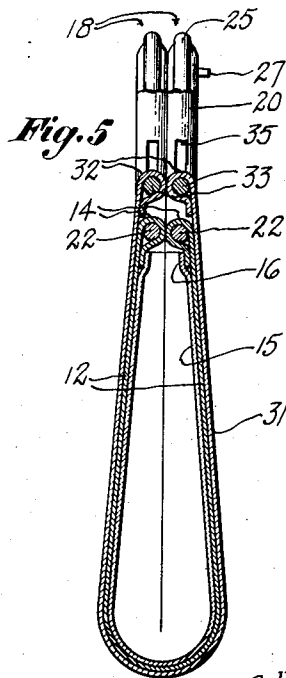
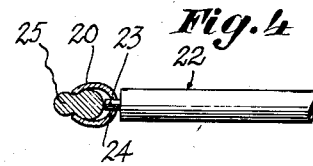
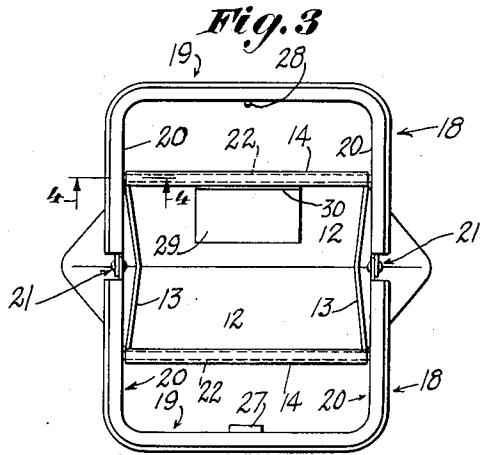
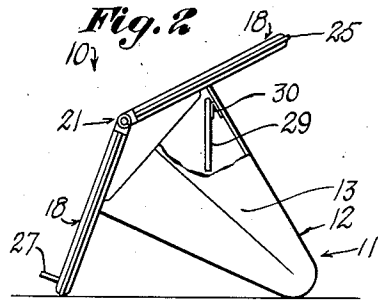
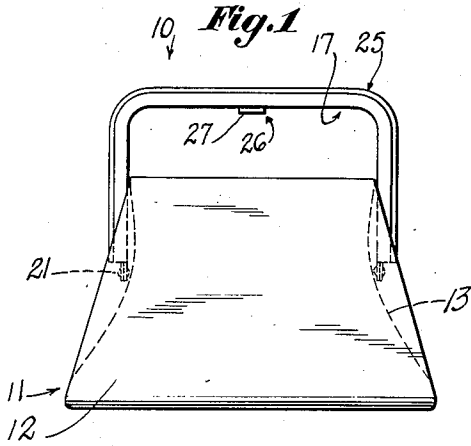

INVENTOR.
Edward Lowy
BY *Mrs. Schumacher* ATTORNEY.

UNITED STATES PATENT OFFICE

2,083,029

HANDBAG

Edward Lowy, Brighton Beach, Brooklyn, N. Y.

Application April 15, 1937, Serial No. 136,976

8 Claims. (Cl. 150—33)

This invention relates to handbags and has particular reference to bag and frame assemblies.

One object of the invention is to provide a handbag comprising an improved frame adapted to be completely preformed so as to be assembled in that condition with a completed bag body, with a minimum of manipulation.

Another object of the invention is the provision of such an improved frame and bag assembly characterized by a novel handle structure which may form an integral part of the frame.

Another object of the invention is the provision of a framed handbag having a removable cover in uniform, neat appearing and improved association therewith or with the novel bag and frame assembly.

Another object of the invention is to furnish a handbag adapted to rest on its frame in an easel-like display manner.

A further object of the invention is the provision of a novel handbag having few and simple parts and which is durable and reliable in use, neat in appearance, and especially inexpensive in manufacture.

Other objects and advantages of the invention will become apparent as the specification proceeds.

With the aforesaid objects in view, the invention consists in the novel combinations and arrangements of parts hereinafter described in their preferred embodiments, pointed out in the subjoined claims, and illustrated in the annexed drawing, wherein like parts are designated by the same reference characters throughout the several views.

In the drawing:

Figure 1 is a view in side elevation showing a handbag embodying the invention, and may represent the same with and without a cover.

Fig. 2 is a view in side elevation, with parts removed, of the handbag set up in easel-like position.

Fig. 3 is a view in front elevation thereof.

Fig. 4 is an enlarged fragmentary sectional view of the bag body mounting, on line 4—4 of Fig. 3.

Fig. 5 is a view in vertical section of the closed bag having a cover thereon.

Fig. 6 is a diagrammatic view of the frame assembly, with parts removed, and the dotted lines showing a U-shaped frame member in sprung position.

Fig. 7 is a diagrammatic view of the frame assembly with a cover rod in course of being applied thereto.

The advantages of the invention as here outlined are best realized when all of its features and instrumentalities are combined in one and the same structure, but, useful devices may be produced embodying less than the whole.

It will be obvious to those skilled in the art to which the invention appertains, that the same may be incorporated in several different constructions. The accompanying drawing, therefore, is submitted merely as showing the preferred exemplification of the invention.

Referring in detail to the drawing, 10 denotes a device embodying the invention, and which may or may not comprise a removable cover for the bag body as hereinafter described. The device 10 may include a bag body 11 having side walls 12 interconnected by infolding end gussets 13. The upper edge portions of the side walls may be infolded to provide marginal tubular portions 14 along the mouth or opening of the bag body, leaving a smooth uniform exterior. A lining 15 may overlie and finish at 16 the inturned tube forming portions as shown in Fig. 5.

The handbag 10 may include a frame 17 that may comprise a pair of like inverted U-shaped frame members 18, each having a top handle bar 19 and end arms 20 depending therefrom, and connected therewith by resiliently bendable curved portions. Preferably these frame members 17 are one piece constructions and consist of slightly resilient material for relative movement between the arms 20 of each frame member. The frame members may be movably or pivotally interengaged as at 21 at the lower ends of said arms for relative movement of the frame members toward and away from each other to close and open the bag body.

Extending freely through the tubular portions 14 of the bag body are the individual rods 22, each having an undercut shoulder forming end pins 23 engaged in aligned opposed holes 24 of the arms 20 of the respective frame members, to thus support the bag body. The rods 22 are thus positioned intermediate of the handle bars and pivot ends and in spaced relation to both. As shown in Fig. 6, the rods 22 are assembled with the frame members by springing apart the arms 20 of the latter, as suggested in dotted lines, to permit the pins 22 of said rods to be sprung into said holes 24. In performing this action the parts of the arms 20 above the holes 24 afford a leverage L to permit the deformation to occur without exceeding the elastic limit of the material. In this simple manner, without change in shape or construction of the preformed bag body 11 and frame 17

the handbag 10 is completely assembled with a minimum of manipulation, to afford a reliable and durable structure, and which is neat appearing and simulates a conventional handbag with the arms 20 lying partially within the external spaces of the gussets 13. Further, the handbag as thus instantaneously assembled is furnished with handles 19 which require no particular construction or labor either as parts of the bag body or frame.

If desired, the frame members 18 may consist of channel material as shown in Fig. 4 so as to receive therein suitable ornamentation such as the corded fabric 25 which is clamped in the channel and may project from the mouth thereof to afford a continuous ornamentation extending along the upper faces of the handle bars 19 and along the outer edges of the arms 20. When such ornamentation is used, any suitable releasable locking device 26 may be disposed on the underside of the handle bars 19, and may include a plate 27 rigidly fixed to one handle bar for riding under and engaging as in a perforation or groove thereof a pin 28 rigidly fixed to the companion handle bar. The free end of the plate 27 then laterally projects beyond the companion frame member. The locking device 26 is operative without the use of springs by reason of the length of the arms 20, the handle bars being spaced above the bag body, so that the frame members have ample inherent resilience for the action of the locking device 26. To release the latter, downward pressure may be exerted at the free end of the laterally projecting plate 27 to release the pin 28. If desired, the plate 27 may be resilient, and, of course, it may be spring actuated in a manner that is usual in the locking devices of ladies' handbags.

The device 10 may be set up in an easel-like manner as shown in Fig. 2 by swinging the frame members 18 about their pivots 21 through an angle somewhat greater than 180 degrees, the pivot or hinge means 21 being of the well known type adapted to act as a stop to limit the swinging movement. The frame 17 now serves the double function of holding the bag body open and supporting the same on a horizontal surface in the easel-like manner, so that the contents of the bag body are conveniently accessible. A mirror 29 may be swingably mounted at its upper edge 30 on a side wall 12 so as to depend in convenient vertical position. When the bag is closed, the mirror lies alongside of the wall 12.

In Figs. 5 and 7 is shown an embodiment including a removable cover 31 for the bag body. The handbag may be exactly the same as in the device 10, except that in the latter the cover may be regarded as removed. The cover 31 may consist of one or more plies of material of different color or texture and may be reversible. It is folded under and extends along the sides of the bag body, and is of sufficient length so that its end tubular portions 32 lie above those of the bag body. Passing freely through the tubular portions 32 are the rods 33 which are identical with the rods 22, except that their end pins 34 are received in slots 35 that extend longitudinally of the arms 20. As shown in Fig. 7, the slots 35 permit the rods to be engaged without expanding the frame members and releasing the rods 22, since one end of a rod 33 is inserted in one slot and the rod tilted to engage the other end in the opposed slot. The normal downward yielding tension of the cover 31 prevents accidental release of the rods 33. The rods 22 and 33 thus lie par-

allel and in the planes of the frame members 18 and in spaced relation under the handle bars 19, with one set of rods at one side of the handbag and the other at the opposite side of the handbag. The use and operation of the handbag as above described is identical and without the cover.

I have thus provided a handbag wherein the bag body, cover, frame and handles may all be fully preformed and assembled without laborious clamping or other operations.

I claim:

1. A handbag having a frame and bag body adapted to be assembled without change in construction, including a bag body, inverted U-shaped frame members each having a top handle bar and end arms, the frame members being pivotally interconnected at the lower ends of said arms and the arms of each frame member having opposed openings intermediate of the pivot ends and handle bar and being resilient so that the spacing between said openings can be varied for releasably engaging the ends of a rod, rods having their ends releasably engaged in said openings, the bag body having an opening and tubular portions along the edges of said opening, the tubular portions being sleeved on said rods to support the bag body and open and close the same upon relative movement of the frame members about their pivots, whereby the finished bag and frame can be assembled by inserting the rods through the tubular portions and snapping the rods into engagement with the frame members.

2. A handbag including a gusseted bag body having an opening having marginal tubular portions, inverted one-piece U-shaped frame members each having a top handle bar and arms depending therefrom, the frame members being permanently pivotally interconnected at the ends of said arms, rod members extending through the tubular portions to support the bag body, each rod member and its corresponding frame member having means for releasable interengagement so that the rod member is positioned intermediate of the handle bar and the pivot ends to open and close the bag body by relative movement between the frame members, whereby different bag bodies may be interchangeably assembled with the frame.

3. A handbag including a bag body having side walls interconnected by end gussets and defining an opening, the side walls having individual tubular marginal portions extending longitudinally of the opening and being integral with the side walls, a frame including a plurality of inverted U-shaped members each consisting of a top cross bar and arms depending therefrom, the latter being pivotally interconnected at their lower ends, each frame member being of one piece construction and consisting of relatively resilient material so that the arms of each frame member are movable toward and away from each other, the arms of each frame having opposed aligned holes, said holes being located in spaced relation to the top cross bar and to the pivot ends of said arms, rods passing through the tubular portions of the side walls and each rod having its opposite ends engaged with said arms and in said holes of its individual frame member by springing apart and then releasing said arms, said rods being retained by said arms against relative longitudinal movement, said top cross bars constituting handles for the handbag; and means releasably interengaging said handles.

4. A handbag including a bag body having an

opening having marginal tubular portions, a cover for the bag body having tubular portions at the ends thereof, the cover being folded around the bag body and the tubular portions thereof being
 5 above those of the bag body, rod elements extending through the tubular portions of the cover and bag body, and a frame means for mounting the rod elements, said frame means including a plurality of inverted U-shaped frame members
 10 each having a top bar and spaced arms, the frame members being pivotally interconnected at the ends of the arms, the rods passing through the tubular portions of the bag body being connected to the side arms intermediate of their pivot ends
 15 and the top bars, and the rods passing through the tubular portions of the cover having releasable socketed engagements at their ends with the said arms above the tubular portions of the bag body and below the top bars.

20 5. A handbag including a bag body having an opening having marginal tubular portions, a cover for the bag body having tubular portions at the ends thereof, the cover being folded around the bag body and the tubular portions thereof being
 25 above those of the bag body, rod elements extending through the tubular portions of the cover and bag body, and a frame means for mounting the rod elements, said frame means including a plurality of inverted U-shaped frame members each
 30 having a top bar and spaced arms, the frame members being pivotally interconnected at the ends of said arms, the arms of each frame member having opposed aligned holes and being resiliently movable away from each other to permit
 35 rods to be sprung into said holes, the latter being located intermediate of the pivot ends and the handle bars, the rods passing through the tubular portions of the bag body having their ends engaged in said holes to support the bag body, said
 40 arms of each frame member having opposed slots extending lengthwise of the arms above said holes and spaced below the handle bars, the rods passing through the tubular portions of the cover having ends smaller than said slots and being
 45 engaged in opposed slots by tiltingly inserting the rods into said slots.

6. A handbag including a frame comprising a

plurality of inverted U-shaped frame members each providing a top handle bar and spaced arms, said frame members being pivotally interengaged at the lower ends of said arms, each frame member consisting of a one piece channel element
 5 providing an outward facing groove, an elongated finished device secured in said groove and extending substantially continuously along the handle bar and the arms, a bag body, and means
 10 connected to the frame members and lying intermediate of and in spaced relation to said pivot ends and said handle bars for mounting the bag body and for opening and closing the same upon relative movement of the frame members about
 15 their pivots.

7. A handbag according to claim 6, including a locking device for releasably closing the handbag, said locking device being secured to the handle bars at their under sides and being located
 20 above the bag body.

8. A handbag including a frame comprising a plurality of inverted U-shaped frame members, each providing a top handle bar and spaced arms, said frame members being pivotally interengaged at the lower ends of said arms, each frame member
 25 consisting of a one piece channel element providing an outward facing groove, an elongated finished device secured in said groove and extending substantially continuously along the handle bar and the arms, a bag body, and means
 30 connected to the frame members and lying intermediate of and in spaced relation to said pivot ends and said handle bars for mounting the bag body and for opening and closing the same upon relative movement of the frame members about
 35 their pivots, said means including rods, and the bag body having marginal tubular portions along the mouth thereof, said tubular portions being sleeved on said rods, the arms of each frame member having opposed portions for releasably
 40 engaging the ends of a rod upon springing apart and releasing the arms of a frame member, and the frame members consisting of a slightly resilient material to permit their arms to be sprung
 45 apart.

EDWARD LOWY.