

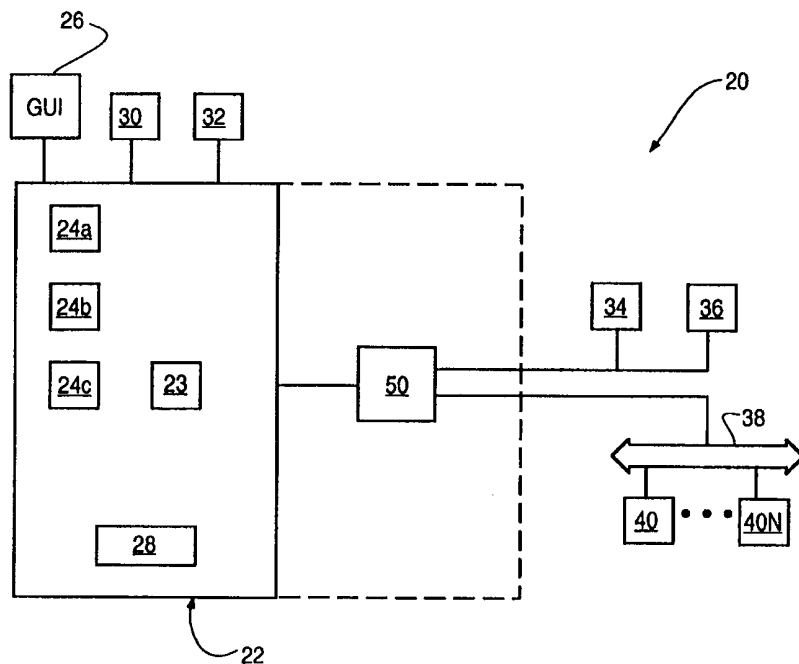

INTERNATIONAL APPLICATION PUBLISHED UNDER THE PATENT COOPERATION TREATY (PCT)

<p>(51) International Patent Classification ⁷ : B60R 16/02, H04L 29/06, B60R 25/00</p>	<p>A1</p>	<p>(11) International Publication Number: WO 00/09363 (43) International Publication Date: 24 February 2000 (24.02.00)</p>
<p>(21) International Application Number: PCT/US99/17852 (22) International Filing Date: 5 August 1999 (05.08.99) (30) Priority Data: 09/131,540 10 August 1998 (10.08.98) US (71) Applicant: LEAR CORPORATION [US/US]; 21557 Telegraph Road, Southfield, MI 48034 (US). (72) Inventor: CHUTORASH, Richard, J.; 3136 Greenspring Lane, Rochester Hills, MI 48309 (US). (74) Agents: HALLER, Timothy, J. et al.; Niro, Scavone, Haller & Niro, Suite 4600, 181 W. Madison, Chicago, IL 60602 (US).</p>	<p>(81) Designated States: JP, European patent (AT, BE, CH, CY, DE, DK, ES, FI, FR, GB, GR, IE, IT, LU, MC, NL, PT, SE). Published <i>With international search report. Before the expiration of the time limit for amending the claims and to be republished in the event of the receipt of amendments.</i></p>	

(54) Title: FIREWALL FOR VEHICLE COMMUNICATION BUS



(57) Abstract

A vehicle computer system provides a firewall between an auto PC and its application software and the vehicle bus and vehicle components. The firewall prevents unauthorized access by software in the auto PC to the vehicle bus and vehicle components. Preferably, the firewall utilizes encryption technology within the handshake between the auto PC software and firewall.

FOR THE PURPOSES OF INFORMATION ONLY

Codes used to identify States party to the PCT on the front pages of pamphlets publishing international applications under the PCT.

AL	Albania	ES	Spain	LS	Lesotho	SI	Slovenia
AM	Armenia	FI	Finland	LT	Lithuania	SK	Slovakia
AT	Austria	FR	France	LU	Luxembourg	SN	Senegal
AU	Australia	GA	Gabon	LV	Latvia	SZ	Swaziland
AZ	Azerbaijan	GB	United Kingdom	MC	Monaco	TD	Chad
BA	Bosnia and Herzegovina	GE	Georgia	MD	Republic of Moldova	TG	Togo
BB	Barbados	GH	Ghana	MG	Madagascar	TJ	Tajikistan
BE	Belgium	GN	Guinea	MK	The former Yugoslav Republic of Macedonia	TM	Turkmenistan
BF	Burkina Faso	GR	Greece	ML	Mali	TR	Turkey
BG	Bulgaria	HU	Hungary	MN	Mongolia	TT	Trinidad and Tobago
BJ	Benin	IE	Ireland	MR	Mauritania	UA	Ukraine
BR	Brazil	IL	Israel	MW	Malawi	UG	Uganda
BY	Belarus	IS	Iceland	MX	Mexico	US	United States of America
CA	Canada	IT	Italy	NE	Niger	UZ	Uzbekistan
CF	Central African Republic	JP	Japan	NL	Netherlands	VN	Viet Nam
CG	Congo	KE	Kenya	NO	Norway	YU	Yugoslavia
CH	Switzerland	KG	Kyrgyzstan	NZ	New Zealand	ZW	Zimbabwe
CI	Côte d'Ivoire	KP	Democratic People's Republic of Korea	PL	Poland		
CM	Cameroon	KR	Republic of Korea	PT	Portugal		
CN	China	KZ	Kazakstan	RO	Romania		
CU	Cuba	LC	Saint Lucia	RU	Russian Federation		
CZ	Czech Republic	LI	Liechtenstein	SD	Sudan		
DE	Germany	LK	Sri Lanka	SE	Sweden		
DK	Denmark	LR	Liberia	SG	Singapore		
EE	Estonia						

FIREWALL FOR VEHICLE COMMUNICATION BUS

Background Art

The present invention relates to computers for automotive vehicles and more particularly to a firewall for protecting vehicle functions from unauthorized access.

It is known to provide a vehicle with a personal computer or "auto PC" which provides a user interface to vehicle functions, such as climate control, audio system, power windows, windshield wipers, etc. In order to provide these features, the auto PC must have access to the vehicle bus. Many vehicle components, including the engine control module, send and receive information and commands via the vehicle bus. Since the auto PC will permit the installation of third party software, unauthorized access to the vehicle bus is a concern. Unauthorized access to the vehicle bus could cause undesirable control of vehicle components. More importantly, unauthorized access to the vehicle bus could impair critical functions of the vehicle, such as the engine control system or braking system.

Disclosure of the Invention

The present invention provides a system and method for preventing unauthorized access by software in the auto PC to the vehicle bus or directly to vehicle components. This accomplished by a firewall between the auto PC software and vehicle bus. The firewall may be implemented solely in software in the auto PC itself,

or may comprise a separate hardware module. Preferably, the firewall utilizes encryption handshaking with auto PC software in the firewall.

Brief Description of The Drawings

5 The above, as well as other advantages of the present invention, will become readily apparent to those skilled in the art from the following detailed description of a preferred embodiment when considered in the light of the accompanying drawings in which:

Figure 1 is a schematic of the present invention.

10

Best Mode of Carrying out the Invention

A vehicle computer system 20 is shown schematically in Figure 1 comprising an auto PC 22, which generally comprises a CPU 23 executing application software 24a-c. Application software 24a-c each comprise code executable by the CPU 23 for providing any of the functions described herein or any of the functions well known to those in the art to be provided by the auto PC. It should also be understood that other software necessary to perform the functions described herein would also be included and that those reasonably skilled in the art would be able to create such software for performing these functions. Software 24a-c specifically refers to application software that would provide access to and control of vehicle components via a graphical user interface 26. The auto PC 22 may also include a feature board 28. Auto PC 22 may also receive input from devices 30 and 32.

15

20

As is known to those familiar with the auto PC concept, the auto PC 22 provides a graphical user interface 26 for receiving information from and providing commands to vehicle components 34, 36, 38 and 40-40n. As is shown in Figure 1, vehicle component 38 is specifically a vehicle bus 38 which in turn provides access to vehicle components 40-40n. Vehicle components 34 and 36 represent any vehicle components which are not accessible via the vehicle bus 38, but are accessed directly by the auto PC.

Generally, vehicle components 34, 36 and 40-40n would include climate control systems, cellular phone, navigation system, audio system, digital video disc system, power windows, windshield wipers, suspension system, engine control system, automatic braking system. Other vehicle components to which convenient access could be provided via the auto PC 22 could also be included. Preferably most of these components 40-40n would be accessible via the vehicle bus 38; however, other vehicle components 34, 36 may be accessed directly and not be accessible via the vehicle bus 38.

Since one of the features of the auto PC 22 is an open platform, the present invention provides a firewall 50 between the application software 24a-c and the vehicle components 34, 36, 38 and 40-40n. The firewall 50 insures that the application software 24a-c is authorized before permitting the application software 24a-c to send commands to any of the vehicle components 34, 36, 38 and 40-40n. The firewall 50 may comprise a separate chip or separate hardware connected between the auto PC 22 and the vehicle components 34, 36 and 38. Preferably, however, the firewall 50 is implemented in software run by the CPU 23 in the auto PC 22.

When application software 24 wishes to access one of the vehicle components, it first initiates handshake with the firewall 50. Preferably this handshake is similar to that used in some remote keyless entry systems. The application software 24 sends a code to the firewall 50. The firewall 50 evaluates the code to determine if it is a valid code. If so, the firewall 50 relays the command to the appropriate vehicle component.

Most preferably, the codes from the application software 24 are encrypted utilizing random or pseudorandom number generation techniques known in remote keyless entry systems. Preferred code encryption techniques are more fully disclosed in the following U.S. Patents: 5,619,575 Koopman, Jr. et al., 5,649,014 Koopman, Jr. et al., 5,696,828 Koopman, Jr., 5,757,923 Koopman, Jr., 5,598,476 Koopman, Jr. et al., 5,398,284 Finn et al., 5,377,270 Finn et al., and 5,363,448 Finn et al., all of which are assigned to the assignee of the present invention and which are hereby incorporated by reference.

In accordance with the provisions of the patent statutes and jurisprudence, exemplary configurations described above are considered to represent a preferred embodiment of the invention. However, it should be noted that the invention can be practiced otherwise than as specifically illustrated and described without departing from its spirit or scope.

Claims

1. A vehicle computer system comprising:
a user interface receiving input from a user;
a CPU receiving said input and generating a command in response to said input;
5 and
a firewall selectively preventing or permitting said command from being transmitted to the vehicle.
2. The vehicle computer system of claim 1 wherein said firewall receives
10 a code from said CPU, said firewall selectively preventing or permitting based upon said code.
3. The vehicle computer system of claim 2 wherein said code is encrypted.
4. The vehicle computer system of claim 3 wherein said firewall restricts
15 access to a vehicle bus.
5. The vehicle computer system of claim 1 wherein said firewall restricts access to a vehicle bus.
20
6. The vehicle computer system of claim 1 wherein said user interface receives user input for controlling a climate control system.

7. A vehicle computer system comprising:

a user interface receiving input from a user;

a CPU receiving said input and generating a command and a code in response to said input; and

5 a firewall receiving and evaluating said code, said firewall sending said command to a vehicle bus only if said code is valid.

8. The vehicle computer system of claim 7 wherein said CPU is installed in the vehicle.

10

9. The vehicle computer system of claim 8 wherein said code is encrypted.

10. The vehicle computer system of claim 9 wherein said CPU controls a plurality of vehicle systems.

15

11. The vehicle computer system of claim 10 wherein said plurality of vehicle systems include a climate control system and an audio system.

12. A method for preventing unauthorized access to vehicle components including the steps of:

receiving a code and a command;

evaluating the code; and

5 selectively sending or not sending the command to a vehicle component based upon said evaluation of said code.

13. The method of claim 12 wherein the vehicle component is a vehicle bus.

10 14. The method of claim 13 further the step of encrypting the code.

15. The method of claim 14 further including the step of receiving the code and command from an auto PC.

INTERNATIONAL SEARCH REPORT

Int'l Application No

PCT/US 99/17852

A. CLASSIFICATION OF SUBJECT MATTER

IPC 7 B60R16/02 H04L29/06 B60R25/00

According to International Patent Classification (IPC) or to both national classification and IPC

B. FIELDS SEARCHED

Minimum documentation searched (classification system followed by classification symbols)

IPC 7 B60R H04L

Documentation searched other than minimum documentation to the extent that such documents are included in the fields searched

Electronic data base consulted during the international search (name of data base and, where practical, search terms used)

C. DOCUMENTS CONSIDERED TO BE RELEVANT

Category °	Citation of document, with indication, where appropriate, of the relevant passages	Relevant to claim No.
Y	EP 0 392 411 A (HITACHI LTD) 17 October 1990 (1990-10-17) column 3, line 4 - line 45 column 7, line 36 - line 46 figures 1,3	1-11
Y	US 5 416 842 A (AZIZ ASHAR) 16 May 1995 (1995-05-16) abstract column 4, line 40 - line 64 figures 1,2	1-11
A	TED DOTY: "A FIREWALL OVERVIEW" CONNEXIONS,XX,XX, vol. 9, no. 7, page 20-23 XP000564023 ISSN: 0894-5926 the whole document	1-4
	-/--	

Further documents are listed in the continuation of box C.

Patent family members are listed in annex.

° Special categories of cited documents :

- "A" document defining the general state of the art which is not considered to be of particular relevance
- "E" earlier document but published on or after the international filing date
- "L" document which may throw doubts on priority claim(s) or which is cited to establish the publication date of another citation or other special reason (as specified)
- "O" document referring to an oral disclosure, use, exhibition or other means
- "P" document published prior to the international filing date but later than the priority date claimed

- "T" later document published after the international filing date or priority date and not in conflict with the application but cited to understand the principle or theory underlying the invention
- "X" document of particular relevance; the claimed invention cannot be considered novel or cannot be considered to involve an inventive step when the document is taken alone
- "Y" document of particular relevance; the claimed invention cannot be considered to involve an inventive step when the document is combined with one or more other such documents, such combination being obvious to a person skilled in the art.
- "&" document member of the same patent family

Date of the actual completion of the international search

1 December 1999

Date of mailing of the international search report

10/12/1999

Name and mailing address of the ISA

European Patent Office, P.B. 5818 Patentlaan 2
NL - 2280 HV Rijswijk
Tel. (+31-70) 340-2040, Tx. 31 651 epo nl,
Fax: (+31-70) 340-3016

Authorized officer

Billen, K

INTERNATIONAL SEARCH REPORT

International Application No

PCT/US 99/17852

C.(Continuation) DOCUMENTS CONSIDERED TO BE RELEVANT

Category °	Citation of document, with indication, where appropriate, of the relevant passages	Relevant to claim No.
A	US 5 555 502 A (OPEL GEORGE E) 10 September 1996 (1996-09-10) abstract figure 3 -----	1,6-11

INTERNATIONAL SEARCH REPORT

information on patent family members

International Application No

PCT/US 99/17852

Patent document cited in search report	Publication date	Patent family member(s)	Publication date
EP 0392411 A	17-10-1990	DE 69006885 D	07-04-1994
		DE 69006885 T	16-06-1994
		JP 2834268 B	09-12-1998
		JP 3057751 A	13-03-1991
		US 5091856 A	25-02-1992
US 5416842 A	16-05-1995	EP 0693836 A	24-01-1996
		JP 8008895 A	12-01-1996
		US 5668877 A	16-09-1997
US 5555502 A	10-09-1996	NONE	