

(12) INTERNATIONAL APPLICATION PUBLISHED UNDER THE PATENT COOPERATION TREATY (PCT)

(19) World Intellectual Property
Organization
International Bureau

(43) International Publication Date
14 May 2021 (14.05.2021)



(10) International Publication Number
WO 2021/087549 A1

(51) International Patent Classification:

A61B 90/00 (2016.01) A61C 9/00 (2006.01)

(21) International Application Number:

PCT/AU2020/051044

(22) International Filing Date:

30 September 2020 (30.09.2020)

(25) Filing Language:

English

(26) Publication Language:

English

(30) Priority Data:

2019904154 04 November 2019 (04.11.2019) AU

(71) Applicant: **IMPLANT SOLUTIONS PTY LTD**
[AU/AU]; 759-767 Springvale Road, Mulgrave, Victoria
3170 (AU).

(72) Inventor: **TUCKMAN, Michael**; c/o 759-767 Springvale
Road, Mulgrave, Victoria 3170 (AU).

(74) Agent: **FPA PATENT ATTORNEYS PTY LTD**; Level
43, 101 Collins Street, Melbourne, Victoria 3000 (AU).

(81) Designated States (unless otherwise indicated, for every
kind of national protection available): AE, AG, AL, AM,
AO, AT, AU, AZ, BA, BB, BG, BH, BN, BR, BW, BY, BZ,
CA, CH, CL, CN, CO, CR, CU, CZ, DE, DJ, DK, DM, DO,
DZ, EC, EE, EG, ES, FI, GB, GD, GE, GH, GM, GT, HN,
HR, HU, ID, IL, IN, IR, IS, IT, JO, JP, KE, KG, KH, KN,
KP, KR, KW, KZ, LA, LC, LK, LR, LS, LU, LY, MA, MD,
ME, MG, MK, MN, MW, MX, MY, MZ, NA, NG, NI, NO,

NZ, OM, PA, PE, PG, PH, PL, PT, QA, RO, RS, RU, RW,
SA, SC, SD, SE, SG, SK, SL, ST, SV, SY, TH, TJ, TM, TN,
TR, TT, TZ, UA, UG, US, UZ, VC, VN, WS, ZA, ZM, ZW.

(84) Designated States (unless otherwise indicated, for every
kind of regional protection available): ARIPO (BW, GH,
GM, KE, LR, LS, MW, MZ, NA, RW, SD, SL, ST, SZ, TZ,
UG, ZM, ZW), Eurasian (AM, AZ, BY, KG, KZ, RU, TJ,
TM), European (AL, AT, BE, BG, CH, CY, CZ, DE, DK,
EE, ES, FI, FR, GB, GR, HR, HU, IE, IS, IT, LT, LU, LV,
MC, MK, MT, NL, NO, PL, PT, RO, RS, SE, SI, SK, SM,
TR), OAPI (BF, BJ, CF, CG, CI, CM, GA, GN, GQ, GW,
KM, ML, MR, NE, SN, TD, TG).

Declarations under Rule 4.17:

— of inventorship (Rule 4.17(iv))

Published:

— with international search report (Art. 21(3))

(54) Title: APPARATUS FOR FACILITATING ACQUISITION OF A SCAN AND AN INTRAORAL SCANNING PROCEDURE

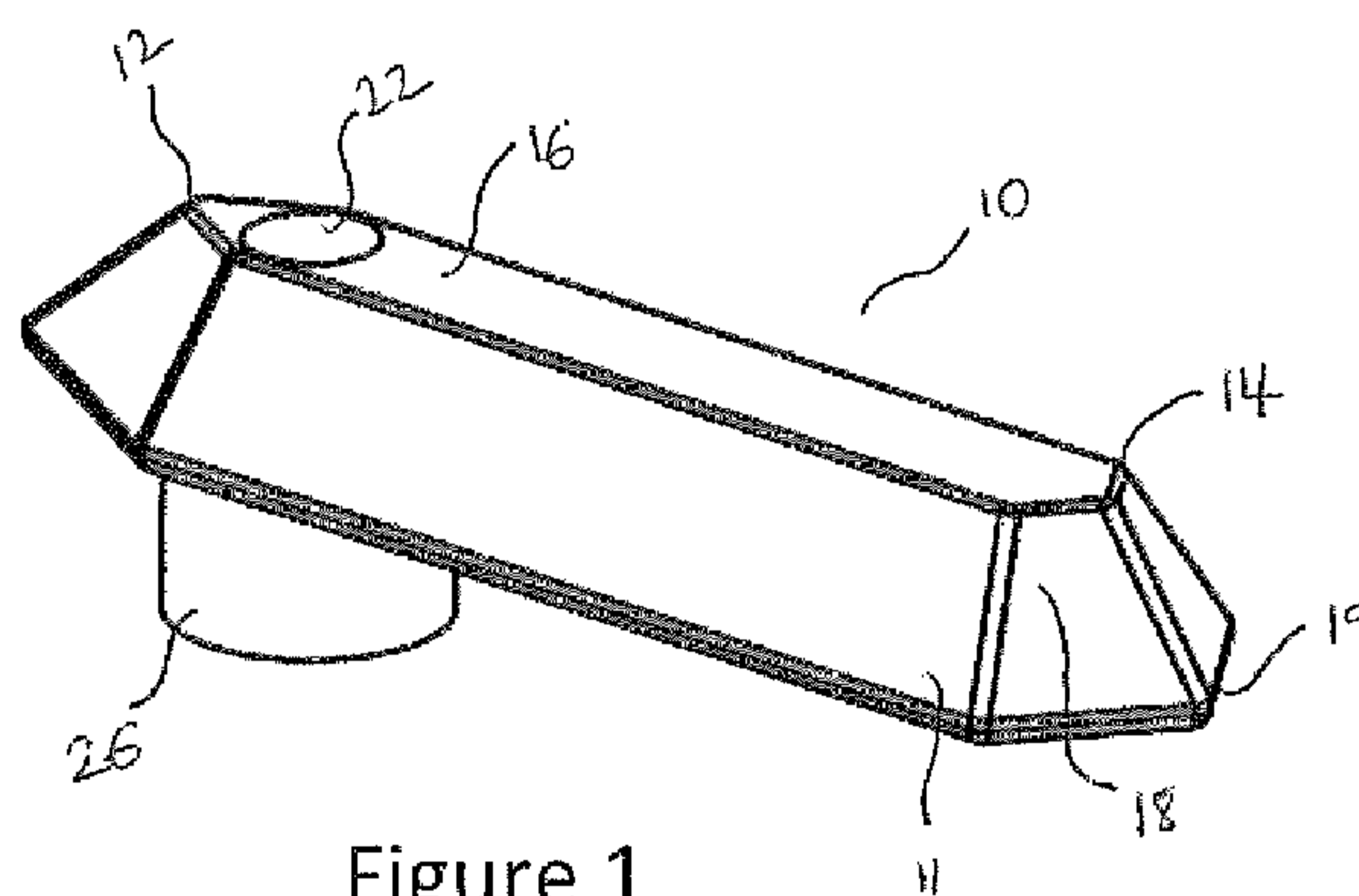

Figure 1

(57) Abstract: The present invention comprises an apparatus for facilitating the acquisition of a scan during an intraoral scanning procedure using an intraoral scanner, including: an elongate body having an attachment portion configured to attach the elongate body with an implant in a patient's mouth, the implant having a longitudinal axis, whereby the elongate body is adapted to extend substantially perpendicular to the longitudinal axis of the implant when mounted to the implant; the elongate body having a substantially planar upper surface and one or more side walls extending downwardly away from the upper surface; wherein the upper surface and the one or more side walls are observable in a resulting scan when the intraoral scanner scans the apparatus in a direction perpendicular to the upper surface. The invention extends to a kit including a plurality of items of the apparatus and to a method of performing an intraoral scanning procedure.



WO 2021/087549 A1

Apparatus for facilitating acquisition of a scan and an intraoral scanning procedure

Field of the invention

[0001] The present invention generally relates to an apparatus for facilitating acquisition of a scan in a patient's mouth and a related intraoral scanning procedure.

Background of the invention

[0002] An implant impression is the main reference of an implant's location within a patient's mouth and is the foundation for designing and manufacturing any prosthetic framework. The accuracy of the implant impression depends on a number of factors. These factors include the number, the depth, and angulation of the implants, the impression technique selected, and the type of impression material. Deciding on the impression technique involves consideration of various options, including selecting a direct or indirect method, selecting a splinted or non-splinted solution, selecting the design of impression coping used, and selecting the type of impression tray (eg. open/closed).

[0003] Any inaccuracy during the impression-taking stage will be transferred to the model created. For this reason, an accurate implant impression is pivotal to the generation of an accurate definitive prosthetic model, which is the principal source for the fabrication of an accurately fitting milled prosthesis. The accurate fit at a clinical-stage of a milled prosthesis with the implant(s) fixed in the patient's jaw (and projecting into the patient's mouth) depends directly on the accuracy of the impression technique. An inaccurate fit between the implants and the prosthetic framework may give rise to a number of problems, including causing internal stresses within the framework, implants, prosthetic screws and bone. The selection options available with regard to conventional implant impressions can also result in variation in the results, depending on the experience of the operators and choice of materials used. Further, the orientation of the implant(s) in the arch can impact on the accuracy of conventional implant impressions. For example, relatively angled implants can give rise to loss of accuracy for conventional impressions, compared with parallel placement of implants.

[0004] The introduction and improvement of intraoral scanning technology has opened the door for the common acquisition of digital dental impressions. A digital impression becomes an alternative that reduces the possible sources of error associated with conventional implant impression methods. Digital impression systems are becoming more common because they allow the capture of digital data that can then be used to replicate the intraoral hard and soft tissues, replacing the need for impression trays and impression materials.

[0005] However, the accuracy of recording multiple implant positions across the arch placed on edentulous patients is a common challenge that affects the consistency of the results. The different intraoral scanner solutions in the market present different data acquisition systems and employ different knitting algorithms in compiling the complete data sets, which can cause variations in the scan information. Some of the factors that affect the accuracy of digital implant impressions are the different scanning protocols, optical settings of the scanning devices and the limitations of different technologies (blue/white light, video scanners, etc.).

[0006] It would be desirable to provide a solution to one or more of the drawbacks generally associated with acquisition of digital dental impressions. Alternatively, it would be desirable to provide an alternative means of acquiring more accurate digital data from a scan that provides the public a useful alternative to what is already in the market.

[0007] Reference to any prior art in the specification is not an acknowledgement or suggestion that this prior art forms part of the common general knowledge in any jurisdiction or that this prior art could reasonably be expected to be combined with any other piece of prior art by a skilled person in the art.

Summary of the invention

[0008] In a first aspect, the present invention provides an apparatus for facilitating the acquisition of a scan during an intraoral scanning procedure using an intraoral scanner, including: an elongate body having an attachment portion configured to attach the elongate body with an implant in a patient's mouth, the implant having a longitudinal axis, whereby the elongate body is adapted to extend substantially

perpendicular to the longitudinal axis of the implant when mounted to the implant; the elongate body having a substantially planar upper surface and one or more side walls extending downwardly away from the upper surface; wherein the upper surface and the one or more side walls are observable in a resulting scan when the intraoral scanner scans the apparatus in a direction perpendicular to the upper surface(s).

[0009] At least in preferred embodiments, the apparatus of the present invention can be used to establish an extremely accurate three-dimensional frame of reference for use in the design of dental prosthetics.

[0010] In other words, the present invention is advantageously designed to allow a user to obtain more accurate scan information from digital implant impressions (i.e. from intraoral scanning) for a range of implant cases, including fully edentulous cases where the implants are distributed throughout the full arch of a patient's mouth. The user can accurately model the position and orientation of the implant(s) inserted into the patient's mouth, thereby allowing for more accurate digital implant positional capture and digital design of prosthetic appliances for the patient that utilise the implant location information. These benefits are achieved because of the unique design of the surfaces of the elongate body of the apparatus. Having the upper surface(s) and at least one or more side walls observable in a resulting scan when the intraoral scanner scans the apparatus in a direction substantially perpendicular to the upper surface, an operator needs only to move the head of the scanner within a limited range of movement, i.e. lingual-labial direction, mesial-distal direction, upward-downward (vertical) direction, rather than the conventional five axes of movement most current scanning procedures require. The extra axes of movement of the head of the scanner during the scanning procedure (i.e. through rotational movement) can introduce significant sources of error when the scans are utilised during the post-processing stage.

[0011] During the post-processing stage, the upper surface(s) and the one or more side walls observable in the scan are used as references that can be ultimately compared with stored information contained within a library on a computer, the stored information including precise models and measurements of the apparatus. From this, the known measurements of the apparatus can be assigned to the scan, thereby

allowing the location and orientation of the implants relative to the soft tissue of the patient's mouth to be accurately determined. Having this information in a digital model allows for the digital design of a best-fit implant framework, for example, a partial or full arch implant bar, whereby the determined location and orientation of the implant(s) can be used to define suitable fixing positions of the implant framework, the framework also fitting the soft tissue of the arch.

[0012] In an embodiment, the one or more side walls surround all or a substantial portion of the periphery of the upper surface, all being viewable from above the upper surface. The benefit of such an arrangement is that the apparatus provides a plurality of reference points and surfaces around the upper surface that can be used in the post-processing steps discussed above and in greater detail below. For example, separate scans of the apparatus can be taken during the intraoral scanning procedure and then aligned with one another during the post-processing stage using the reference points and surfaces situated around the periphery of the upper surface, along with the upper surface itself. This provides for more accurate alignment between scans, and greater confidence in the accuracy of the scans when the precise measurements of the location and the orientation of the implant(s) are determined.

[0013] In an embodiment, the upper surface and a lower surface of the elongate body define elongated hexagons, each with its elongated sides extending substantially in parallel from a first end to a second end. The pair of shorter hexagonal sides at the first end of both the upper surface and the lower surface may be longer in length relative to the pair of shorter hexagonal sides at the second end of both the upper surface and the lower surface. These faces may therefore define a relatively acute angle between the pair of sides at the first end, whereas they meet at a larger, relatively obtuse angle at the second end. These faces may therefore be of substantially trapezoidal shape.

[0014] In an embodiment, the one or more side walls taper inwardly towards the upper surface of the elongate body, thus providing a sloped skirt depending from the upper surface. The angle of this tapering may be selected as desired for best results. Ideally, each of the one or more side walls is substantially planar. Alternatively, one

or more of the side wall(s) may be of curved form. Preferably, a plurality of side walls, defining a plurality of interconnected facets, is provided, each facet observable by the intraoral scanner when scanning in a direction substantially perpendicular to the upper surface.

[0015] By way of particular example, the facets may be substantially planar and inclined from the direction perpendicular to the upper surface by an angle between about 15° and about 40°, preferably around 25°.

[0016] In one embodiment, the elongate body includes a first end and a second end, both ends having generally pointed end shapings, each defined by two meeting facets. This has the advantage that, when used in conjunction with other adjacent apparatus, shadowing or obscuring of one apparatus by another can be minimised.

[0017] In one embodiment, the apparatus includes a fiducial marker mounted to or integral with the upper surface. The incorporation of the fiducial marker can assist in the alignment between separate scans because the marker acts as a further point of reference for accurately aligning the scanned apparatus, particularly for alignment in the vertical direction. This is because the marker has known dimensions and is provided in a known position and orientation relative to the elongate body. The fiducial marker provides an additional source of 3-D information in the scan data capture that can be used for vertical corrections between scans that may be required during the post-processing stage.

[0018] The fiducial marker may be of any suitable shape. In one form, the fiducial marker is spherical, but other shapes such as triangular, square, conical, cylindrical, oval, etc. may be used. The fiducial marker may be mounted to the upper surface of the elongate body in any suitable manner. Alternatively, the fiducial marker may be integral with the upper surface by either manufacturing the fiducial marker with the elongate body as one integrally formed component, or by permanently fixing the fiducial marker to the elongate body, such as by welding or other suitable process.

[0019] In an embodiment, the attachment portion may be configured to receive a fastening element, such as a prosthetic screw, in order to fixedly attach the elongate body to an implant in the patient's mouth (or to some other intermediate

component(s) between the implant and the elongate body). The apparatus may then be removable from the implant (eg. following unscrewing the prosthetic screw) once the scanning is complete.

[0020] In an embodiment, the upper surface of the elongate body includes an aperture or recess configured to receive an indicator element that is identifiable in a resulting scan. The recess may be provided by a bore through the elongate body, the bore serving the engagement of the elongate body with the implant. The indicator element may be in the form of a plug, configured to be retained in the recess when the apparatus is being scanned. This can be useful during post-processing, as the indicator element can be used to identify a characteristic of the apparatus or of the scan. For example, if a plurality of apparatus are being scanned (for example as part of the scanning of a full arch), the element may be placed in the recess of the first apparatus to be scanned, thereby indicating the starting position of the scan path. Such information can assist in conveying information about the scanning path. This information can be important as generally the scan data of an apparatus scanned at the beginning of a scan path will be more accurate than that of an apparatus scanned towards the end of the scan path.

[0021] In one embodiment, one or more side walls adjacent the attachment portion include at least one cut-out portion configured to enable the scanner to retrieve data to assist in defining the longitudinal axis of the implant. The cut-out portion(s) preferably extend towards the attachment portion, thereby enabling visualisation of a surface of the attachment portion beneath the elongate body. For example, the cut-out portion(s), when viewed from the direction perpendicular to the upper surface by the scanner, enable a view of a convex surface associated with a bore of the attachment portion, which is to be attached to the implant. This additional information provided by virtue of the cut-out portion(s) can be used during post-processing to assist in correcting any scan discrepancies (such as x-y scan data) along the z-axis that could arise in a resulting scan. Further advantages arise based on the nature of conventional intraoral scans and the resulting post-processing. The cut-out portion(s) can act as a smooth transition path that joins surfaces created by the scanner by connecting the observable surfaces of the apparatus and surfaces of underlying tissue as a complete scan. This is achieved without the need to tilt the head of the

scanner in a direction perpendicular with the longitudinal axis of the implant in the way conventional scan apparatus require. It is this tilting or rotation of the head of the scanner that can introduce inaccuracies in the resulting scan. The joining of surfaces between the apparatus and the underlying tissue also mitigates the tendency of most post-processing software to treat separated or inconsistent scan data as noise, which in some cases results in automatic deletion of this data.

[0022] Preferably, there are at least two cut-out portions, with at least one located on a posterior side of the apparatus and at least one located on an anterior side of the apparatus.

[0023] In one embodiment, one or more of the upper surface and side walls include an identifier which enables identification of the apparatus in a resulting scan. Preferably, the identifier is provided on the upper surface. The identifier may be of any suitable form, such as one or more projections, one or more recesses, a scannable medium (e.g. barcode), etc. The identifier can convey different types of information about the apparatus, such as height, length, width or dimensional tolerance, etc. This is particularly important when the apparatus is used in conjunction with other similar apparatus as part of a scanning procedure.

[0024] In a second aspect, the present invention provides a method of performing an intraoral scanning procedure, including inserting one or more implants into a patient's jaw, each of the one or more implants having a longitudinal axis, mounting the above-defined apparatus to the one or more implants in the patient's mouth, and scanning the apparatus and at least a part of the soft tissue in the patient's mouth, thereby producing a set of scan data for use in determining the relative position and orientation of the one or more implants relative to the soft tissue.

[0025] In one embodiment, the method may further include selecting one or more modular forms of said apparatus from a plurality of different modular forms of the apparatus, in order to best fit a space to be scanned in the patient's mouth.

[0026] In another embodiment, where a plurality of implants are inserted into the patient's jaw, the method further includes mounting each apparatus to its respective

implant in a way resulting in a substantial elongate overlap transition from each apparatus to each adjacent apparatus, across the space to be scanned.

[0027] It will be appreciated that the second aspect of the invention can include any of the features defined with respect to the first aspect of the invention.

[0028] In a third aspect, the present invention provides a kit including a plurality of items of the above-defined apparatus, including items of different dimensions to each other, such that a plurality of items may be selected for a particular patient's mouth in accordance with the area of the patient's mouth to be scanned and/or in accordance with relative positions of one or more existing implants.

[0029] The different dimensions can include different lengths and/or heights. Different heights can be provided to accommodate the depth of a given implant relative to the surrounding tissue. For example, undue pressure exerted by the tissue on the underside of one item can be avoided by using an item with a greater height. Further, an item of suitable height can be used to ensure the depth of field of the scanner head is closer to the tissue, without touching the tissue, thereby improving accuracy of the scan and hence better stitching between the scan data. In a similar fashion, different lengths can be provided to accommodate different distances between implants.

[0030] In one embodiment, each unique item in the kit is measured and the measurements are stored in a digital library for post-processing of a resulting scan.

[0031] It will be appreciated that the third aspect of the invention can include any of the features defined with respect to the first or second aspect of the invention.

[0032] In a fourth aspect, the present invention provides a method of performing an intraoral scanning procedure for determining the position and orientation of one or more implants in a patient's mouth, each implant having a longitudinal axis, the method using one or more scannable bodies and including providing a scannable body on each of the one or more implants, the scannable body extending substantially perpendicular to the longitudinal axis of the respective implant, the scannable body having a substantially planar first surface facing in a direction away

from the soft tissue of the patient's mouth, and one or more further surfaces extending from the first surface, wherein the one or more further surfaces are viewable from a direction perpendicular to the first surface, scanning the one or more scannable bodies, thereby producing a set of scan data associated with the intraoral scanning procedure, and assigning information from a set of stored data to the scan data, and determining from the scan data and the assigned information the position and orientation of the one or more implants.

[0033] It will be appreciated that the fourth aspect of the invention can include any of the features defined with respect to the first, second, and third aspects of the invention.

[0034] As used herein and except where the context requires otherwise, the term "comprise" and variations of the term, such as "comprising", "comprises" and "comprised", are not intended to exclude further additions, components, integers or steps.

[0035] Further aspects of the present invention and further embodiments of the aspects described in the preceding paragraphs will become apparent from the following description, given by way of example and with reference to the accompanying drawings.

Brief description of the drawings

[0036] Figure 1 illustrates a perspective view of an apparatus according to an embodiment of the present invention;

[0037] Figure 2 illustrates a front elevation view of the apparatus of Figure 1;

[0038] Figure 3 illustrates a plan view of the apparatus of Figure 1;

[0039] Figure 4 illustrates a side elevation view of the apparatus of Figure 1;

[0040] Figure 5 illustrates a bottom plan view of the apparatus of Figure 1;

[0041] Figure 6 illustrates a plan view of a plurality of apparatus according to an embodiment of the present invention inserted into the mouth of a patient;

[0042] Figure 7 illustrates an example of resulting scans in software during a post-processing step in a method in accordance with an embodiment of the present invention;

[0043] Figure 8 illustrates an upper perspective view of an apparatus in accordance with another embodiment of the invention;

[0044] Figure 9 illustrates a plan view of the apparatus of Figure 8;

[0045] Figure 10 illustrates a front elevation view of the apparatus of Figure 8; and

[0046] Figure 11 illustrates a kit including a plurality of apparatus of different dimensions in accordance with an embodiment of the invention.

Detailed description of the embodiments

[0047] It will be understood that the invention disclosed and defined in this specification extends to all alternative combinations of two or more of the individual features mentioned or evident from the text or drawings. All of these different combinations constitute various alternative aspects of the invention.

[0048] Reference is made to Figures 1 to 5 which illustrate in various views an embodiment of the apparatus of the invention. A scan abutment (or scan gauge) 10 is configured to be attached directly or indirectly to an implant in a patient's mouth, eg. an implant pin (ie. dental implant) surgically implanted to the patient's mandible or maxilla. In some examples, scan abutment 10 can be attached to an intermediate adaptor (not shown) such as a multi-unit adaptor (as known in the art), which is attached to the implant. It will be noted that references to the implant can include (where the context permits) reference to the intermediate adaptor.

[0049] References herein to a vertical direction refers to the vertical direction as generally understood in the anatomical position (i.e. patient upright). References herein to upper and lower are to be understood in relation to the scan abutment as viewed in the accompanying drawings. However, as will be understood, depending on whether the scan abutments are used in the upper or lower arch of the patient's mouth (ie. with a maxillary or mandibular implant, respectively), the terms upper and

lower may be reversed. In the depicted embodiment, the scan abutments are used in the lower arch of the patient's mouth (ie. attached to mandibular implants), so the terms 'upper' and 'lower' will be used from that viewpoint.

[0050] The scan abutment 10 includes an elongate prismatic body 11 having a first end 12 and a second end 14. Body 11 is preferably a solid body, but can instead be a hollow body. Body 11 further includes a planar upper surface 16, a planar lower surface 17 and a plurality of side walls 18 extending between the peripheral edges of the upper surface 16 and the peripheral edges of the lower surface 17. As can be seen, the upper and lower surfaces 16, 17 are in the form of similarly shaped elongated hexagons, each with its elongated sides extending in parallel from the first end 12 to the second end 14. The pair of shorter hexagonal sides at the first end 12 of both the upper surface 16 and the lower surface 17 are longer in length relative to the pair of shorter hexagonal sides at the second end 14 of both the upper surface 16 and the lower surface 17. These faces therefore define a relatively sharp, acute angle between the pair of sides at the first end 12, whereas they meet at a larger, obtuse angle at the second end 14. This difference in morphology arises from a need to minimise lateral overlap (and the creation of associated shadowing) which can adversely impact on scanning accuracy.

[0051] Prismatic body 11 therefore has the form of a stretched hexagonal frusto-pyramid, with a single plane of symmetry running along the longitudinal centreline.

[0052] It will be appreciated by a person skilled in the art that the upper surface 16 and lower surface 17 need not necessarily have the same shape as depicted in this embodiment, but can take on any other suitable shape such as rectangular, oval, triangular, polygon, etc. However as will be evident from the discussion below, a series of straight edges and associated planar side wall facets are preferred. Further, the overall shape of the body 11 does not necessarily require the upper surface 16 and the lower surface 17 to have the same shape, with variations in the overall shape to that shown in the present embodiment also possible.

[0053] The side walls 18 include a number of distinct facets, in the depicted example six facets 18a-18f, that extend between the respective edges of the upper surface 16

and the lower surface 17 around the whole periphery thereof. The peripheral edge of the lower surface 17 includes a chamfered transition lip 19, from which facets 18a-f extend upwardly towards upper surface 16. As can be seen in the figures, the facets 18a-f generally taper inwardly from the chamfered transition lip 19 to the upper surface 16, thereby defining a series of interconnected planar sloped walls. The slope of the side walls 18a-f can be selected as desired. Ideally, this slope is between 15° and 40° to the vertical (ie. the direction perpendicular to upper surface 16), and is preferably around 25° to the vertical. In other embodiments, the side walls may be curved, or a single curved side wall may extend from and surround the entire upper surface 16. However, preferably, for ready surface identification and data manipulation, planar facets are preferred.

[0054] Significantly, when the scan abutment 10 is viewed by the scanning head of an intraoral scanner in a direction substantially above and perpendicular to the upper surface 16 (with scan abutment 10 mounted to the proximal end of an implant in the patient's mouth), the six facets 18a-18f and the upper surface 16 are all directly observable in the scan (as illustrated in the plan view of Figure 3). In this way, all seven facets can act as reference surfaces when aligning separate scans taken of the scan abutments 10 within the patient's mouth. This provides full 3-D reference information concerning the relative position and orientation of the scan abutment, and thus the position and orientation of the implant relative to the soft tissue in that area of the patient's mouth.

[0055] This is of significant benefit, as the scan operator need only manoeuvre the scan head in a limited range of movement within the patient's mouth, i.e. lingual-labial direction, mesial-distal direction, and – as necessary – the vertical direction. Manoeuvring the scan head in these directions will capture the upper surface 16 and the side walls 18 without the need for the scan head to be manoeuvred in any rotational directions. This is important because rotational movements of the scan are found to provide the greatest source of potential error in capturing internal scan data. This is generally related to the internal knitting algorithms that interpolate any gaps present in the image data, which can result in significant distortion of the overall scan and thus inaccuracy. It is of course nearly impossible to eliminate some rotational movement from occurring during the scanning procedure and to eliminating at least

some instances of the scanner software being required to stitch together gaps in the scan image. However, by eliminating the need for substantial rotation of the scan head during the scanning procedure, the operator can largely maintain movement of the scan head in only the limited range of movement discussed above, severely limiting the amount of data knitting required.

[0056] As noted above, from the lower surface 17 extends chamfered transition lip 19. The transition lip 19 provides that the scan abutment 10 has a relatively sharp lower edge detail to side walls 18. This assists in reducing the risk of tissue overlap of the lower portions of the side walls 18. The lower edge detail also assists in more precisely defining the implant/tissue boundary. This can improve scan accuracy by minimising interpolation errors that can arise, for example when tissue is mistaken for implant.

[0057] Whilst it is advantageous for the scan abutments 10 to include side walls that are visible around the whole periphery surrounding the upper surface 16, this need not be the case. For example, having side walls that are visible around only a portion of the periphery of upper surface 16 can still provide sufficient reference surfaces for use in providing a suitable data set and in comparing and aligning separate scans of the scan abutments 10. However, it will be apparent to a person skilled in the art that the more points and facets of reference that are visible, the greater the accuracy and usefulness of the scan.

[0058] As can be seen from the overall shape and configuration of the scan abutment 10, the first end 12 and the second end 14 of the scan abutment 10 terminate in pointed ends, provided by the meeting of facets 18a;18f and 18c;18d, respectively. The benefit that arises from using scan abutments with these pointed ends is best appreciated in scenarios where multiple scan bodies are placed in the mouth of the patient (for example, when scanning a full or partial arch). In a preferred scanning procedure, scan abutments 10 are placed adjacent one another in order to take the most accurate scan of the desired scanning region. Having the scan abutments in close proximity means that if the ends of the scan abutments were, for example, curved, some of the surfaces of the side walls may be obscured by a directly adjacent scan abutment, thus limiting the detail available for the post-

processing stage. Having relatively pointed ends reduces the likelihood of such overlap when the scan abutments are in close proximity.

[0059] The elongate body 11 includes a bore 22 extending between the upper surface 16 and the lower surface 17, adjacent the first end 12. The bore 22 is configured to accommodate the proximal end of an implant (or intermediate adaptor) and to receive a prosthetic screw to secure the scan abutment 10 to the implant. Extending vertically from the lower surface 17 is a cylindrical attachment portion 26 configured to sit over the implant when the scan abutment 10 is attached thereto. In some embodiments, the implant or suitably attached intermediate adaptor can provide a male connection portion complementarily shaped to fit within bore 22, with the lower end of the attachment portion 26 resting upon a planar lower surface of the implant or adaptor. The male connection portion may be in the form of a cylindrical cap that permits a snug fit between the bore and male connection portion.

[0060] Whilst the depicted embodiment provides for a screw connection between the scan abutment 10 and the implant, other means of connecting the scan abutment 10 with the implant are also possible. For example, the scan abutments may include internal threading that can be mated with the implant bearing corresponding threading external, or bore 22 may connect to the proximal head of the implant in a snap-fit arrangement.

[0061] Bore 22 may serve an additional function to receive an indicator element that can convey additional information in a scan. In one embodiment, the indicator element is in the form of a plug (not shown) that fits within and covers the upper end of bore 22. The indicator element may, for example, be used to indicate the direction in which a scan has been taken. For example, if the scan is taken of a plurality of scan abutments from left to right, the indicator element may be placed on the left-most scan abutment, providing an indication in the scan data that the left-most scan abutment was scanned first.

[0062] Recording the direction of a scan in this way can be particularly helpful as, ordinarily, when the scan head travels from the start to the end of a scan path, the information provided at the start of the path is likely to be more accurate than that

provided towards the end of the path. This difference in accuracy arises from errors that accumulate as the scan head traverses a scan path from start to finish. Errors are minimised by overlapping the left-to-right scan with the right-to-left scan using the perpendicular lengths of several markers. This yields a combination of several scans that can be suitably grouped together and used to assist in weighting the acquired image data. However, as will be understood, the indicator element could be used in any other way that can convey suitable information in the resulting scan to the end user.

[0063] In one embodiment, the scan abutment 10 includes a fiducial marker (not shown) mounted to or integral with the elongate body 11. The fiducial marker is preferably in the form of a three-dimensional shape such as a sphere, prism, etc. The fiducial marker is of known dimensions and known position/orientation relative to scan abutment 10, thus providing further 3D reference information that can be used in the post-processing steps of aligning separate scans, particularly for alignment in the vertical direction.

[0064] The scan abutments 10 can be provided to an operator as a kit 1000 (illustrated in Figure 11) with an assortment of elements of different dimensions that can be selected by the operator to suit the size and shape of the patient's mouth, so to provide the amount of coverage required for the scan procedure. In most cases, a plurality of scan abutments 10 will be used to span the space between multiple implants inserted in the patient's mouth, each scan abutment 10 attached to a separate implant. As will be understood, greater flexibility is provided by having scan abutments of different dimensions. For example, suitable dimensions for the scan abutments 10 can include an overall length ranging from about 10mm to about 30mm, and overall heights (ie. viewed in elevation) ranging from about 3mm to about 10mm. However, these dimensions are only exemplary, as a scan abutment can be manufactured to any suitable size.

[0065] The scan abutments 10 are typically fabricated from Titanium Grade 5. However, other suitable materials may be used, such as an alternative suitable metal or a plastics material.

[0066] Scan abutments 10 are generally designed in CAD/CAM software and then manufactured on suitable 5-axis CNC machines. As the precision of the manufactured scan abutments is critical for the scanning procedure, after the manufacture of each scan abutment, a coordinate measuring machine (CMM) is used to precisely measure all the relevant dimensions of the scan abutment. This information is stored on a database so that it can be called upon during the assignment step in the method, as described in detail below. Hence each individual kit can also include its own unique digital library, with precise measurements of each scan abutment 10 of the kit stored in the library. The digital library for each kit of scan abutments will thus be unique to that kit. A kit identifier (such as a kit number) can be assigned to each kit and therefore to each scan abutment within the kit. This ensures that the assignment step of the method described below produces the most accurate representation of the scan bodies and hence the precise positions of the implants (as well as the other scanned data points) in a patient's mouth.

[0067] An exemplary method of using the scan abutments 10 will now be described, in particular as part of a scanning procedure for a full arch of an edentulous patient. However, a person skilled in the art will appreciate that a similar method can be applied when scanning a portion of the full arch. The exemplary method includes providing a plurality of implants within the mouth of a patient, being screwed pins fixed into the maxillary or mandibular bone in a conventional surgical procedure. The suitable number and positioning of the implants will depend on the particular circumstances and the prosthesis required. Generally, to support a fixed complete prosthesis in the maxilla, four implants provide sufficiently high predictability, with clinicians often placing six implants. Whilst it may be ideal in many cases for the implants to be placed parallel to one another, due to surgical or structural limitations this is often not achieved.

[0068] A plurality of scan abutments are then provided, each attached to the proximal head of an implant. This attachment is achieved by engaging the bore 22 of the scan abutment 10 over the head of the implant and attaching thereto by a prosthetic screw accessed from the upper end of the bore. The scan abutments 10 are selected and positioned to substantially cover the full area of the arch, with an example implementation shown in Figure 6. The scan abutments should be

positioned in proximity to each other, but they do not need to touch and it is considered preferable to have an overlap transition from around the midpoint of one abutment to the midpoint of the next (when viewed in elevation – see Figure 6). This is to minimise and simplify the stitching of the scanned data (thus reducing potential for errors to arise in the data post-processing) and to ensure that two or more known surfaces (facets) belonging to adjacent scan abutments 10 are visible in the scanner field of view when moving between the scan abutments.

[0069] As will be understood, the implementation shown in Figure 6 is only one example of positioning the scan abutments. Care should be taken when arranging the scan abutments so that most and preferably all of the upper surfaces and side walls of the scan abutment will be visible from above (and thus to the scanner head). Care should also be taken to avoid significant gaps between adjacent scan abutments as much as possible, as these gaps can provide sources of error. Further, a head-to-tail arrangement of the scan abutments as shown in Figure 6 is considered preferable for acquiring maximum information and minimising sources of error.

[0070] Once the scan abutments are in place, the operator begins the intraoral scanning procedure using a conventional intraoral scanner. The practitioner may first place an indicator element in the bore 22 of a selected scan abutment, so as to provide an indication of which scan abutment was the first scanned during the procedure. The operator will then begin to scan from one end of the arch to the other, preferably manoeuvring the scanner in a generally zig-zag path as shown in Figure 6. As will be understood, the operator will only need to manoeuvre the scan head in a limited range of movements (as discussed above), avoiding the need for any rotational movement of the scan head. Preferably, the operator will then scan the scan abutments along the opposite direction to the initial scan (i.e. from right to left), to generate a second data set. For improved accuracy, further scans in both directions can be performed by the operator so that the multiple scans can be utilised in the post-processing stages. In addition, the operator takes scans of the same portion of the patient's mouth with the implants in place but without the scan abutments, in order to acquire full impression information regarding the soft tissue. This can be done before or after the scan abutments are in place. Further, scans can be taken before implants are installed in the mouth, although this is not considered

essential due to the slight differences that can be created by the implant placement surgery. Each set of scan data takes the form of an STL file containing raw point cloud data.

[0071] This scan data is then passed to post-processing. As part of the post-processing stage, the received STL files which contain the separate scans of the arch with the scan abutments are compared and aligned with one another. One example of this process is shown in Figure 7, where using computer software the sets of scan data of the various scans are aligned with one another and the discrepancies between the respective scans highlighted. For example, if during this alignment stage the discrepancies between the respective scans is in excess of 50 μm , the inaccurate scan may be omitted from the alignment process. The alignment process provides a measure as to how well each of the scan abutments align between the separate scans.

[0072] Each scan abutment can be appropriately aligned in each scan using the known key surfaces (the upper surface and the side walls). Ideally, all seven facets of scan abutments are used. However, if one or more of the key surfaces may be determined to be inaccurate it can be omitted from further processing. This can be due to being obscured in the scan in some way, or to an inaccuracy that has arisen in the scan which has prevented the surface from being aligned with the corresponding surface in another scan. This will be apparent if the surface of the scan abutment has a discrepancy relative to the other scans that is higher than an allowable threshold (such as a facet deviation between scans larger than 10 microns). In such circumstances, this surface or these surfaces may be omitted from consideration during the alignment stage and only the more accurately aligned surfaces taken into account in an averaging process between the (non-rejected) information from the different scans. In processing the data, if there is a scaling error from one scan to another, then the actual marker measurements can be used to re-scale up or down to allow accurate comparison of data sets.

[0073] Once the alignment process has been completed to a satisfactory level, the scan abutments can be separated in the software from the rest of the scanned elements (the soft tissue information), and a file of the now averaged scan saved for

use in the subsequent steps. The stored digital files of the respective scan abutments can now be accessed and used to assign the exact measurements of the respective scan abutments to the averaged scan. The accurate dimensions for each facet of the scan body are assigned to the averaged scan and from this the precise positioning and orientation of each of the implants are determined, relative to the precise form of the soft tissue. This information, in combination with the scan taken without the scan bodies (showing all the underlying soft tissue) allows an end user to digitally construct an implant framework for mounting to the implants by using the position and orientation of the implants as the corresponding mounting points of the implant framework. In addition, peripheral soft tissue data captured in the scan body can be matched with the underlying soft tissue scan in order to identify structures common to the two scans. In turn, these identified common structures can be used in operations such as merging multiple scans.

[0074] It will be appreciated that other information may be required to ultimately construct a dental prosthesis for a patient who has not previously had a dental prosthesis. The reader is directed to Applicant's earlier application PCT/AU2020/050215 (the contents of which are incorporated herein by reference) for information relating to the taking of impressions of the patient's mouth.

[0075] It will also be appreciated that a similar method can be applied in circumstances where a new prosthesis is to be manufactured for a patient having a pre-existing prosthesis, and therefore implants already inserted in the patient's mouth. It is relatively common for pre-existing prosthesis to become worn or damaged over time, and there can be great challenges in manufacturing a suitable replacement prosthesis for the patient. However, this process can be simplified substantially by the present invention.

[0076] A number of additional steps relative to the above described methodology can be employed in such circumstances. In a first step, a scan of the existing prosthesis (e.g. an upper arch) in-situ is acquired. This is then followed by acquiring a scan of the opposing arch. A full bite scan can then be acquired, the bite scan providing information relating to both the upper and lower arches. In a next step, the pre-existing prosthesis is removed. Once removed, the implants (or intermediate

adaptor) are now visible. Depending on the spacing between the existing implants, scan abutments 10 of suitable dimension (in accordance with the purpose described above) are selected and fixed to the implants. In a similar manner to that described above, the scan abutments 10 are scanned, and a further scan is taken of the underlying tissue with the scan abutments 10 removed.

[0077] In the present example, given that there already exists a pre-existing prosthesis, the information provided by the existing prosthesis can simplify the post-processing and teeth design stage. Thus, the present method includes acquiring a 360° scan of the existing prosthesis outside of the mouth. To assist with alignment of the scans during post-processing, cylindrical caps 50 (included in the kit, as shown in Figure 11) of known dimension can be attached to fixing formations on the existing prosthesis before the scan is taken. These caps 50 effectively simulate the precise location of the implants (or intermediate adaptors) and therefore provide a geometric shape of known dimension that are fully visible in the scan. This scan can be used with the acquired scan of the scan abutments to generate an accurate model of the location of the implants in the patient's mouth. Combined with the scan of the patient's tissue, an accurate representation of the overall mouth of the patient is provided which allows for design of a new dental prosthesis, such as prosthesis described in the Applicant's prior application PCT/AU2019/051222, the contents of which are incorporated herein by reference.

[0078] As noted above, caps 50 can be provided along with scan abutments 10 as part of kit 1000.

[0079] Reference is now made to Figures 8-10, which depict a slightly modified form of scan abutment 100. Scan abutment 100 includes several common features to scan abutment 10, and therefore these features will not be described in any detail again. Common features between scan abutment 10 and scan abutment 100 will be provided with a '100' series reference numeral when referencing scan abutment 100.

[0080] In addition to the features described with reference to scan abutment 10, scan abutment 100 includes part-cylindrical cut-out portions 130 provided in opposed side walls adjacent bore 122. In the depicted example, two cut-out portions 130 are

provided, one in side wall 118e and one in side walls 118b, as shown in Figure 9. As will be best appreciated from the figures, the cut-out portions 130 enable direct visualisation, when viewed from above, of part of outer surfaces 132 of the attachment portion 126 around concentric bore 122. As attachment portion 126 sits over the implant when the scan abutment 100 is attached thereto (aligned with the longitudinal centreline of the implant), visual access to surfaces 132 enables the scanner to acquire additional data along the longitudinal axis of the implant. This additional information can assist during post-processing to correct any vertical direction discrepancies that may otherwise arise from the scan, as well as provide further information of the location of the implant relative to the underlying tissue.

[0081] Related to this, the outer surfaces 132 of attachment portion 126 act as a smooth transition path between scanned data representing the observable surfaces of the scan abutment 100 and surface features of the underlying tissue. This is achievable without the need to tilt the head of the scanner in a direction perpendicular with the longitudinal axis of the implant so to view the surfaces of attachment portion 126. The contiguous scan information in the transition from scan abutment 100 to the underlying tissue can significantly mitigate the risk, inherent in conventional post-processing software, that physically separated or otherwise mutually inconsistent scan data is treated as noise and is automatically deleted from the dataset.

[0082] Cut-out portions 130 may be formed by a milling step undertaken during manufacture of scan abutment 100. Alternatively, cut-out portions 130 may be formed by other manufacturing methods, such as provided as recessed portions in a casting of the scan abutment.

[0083] Scan abutment 100 further includes an identifier marking, shown as a pair of circular recesses 140 formed in the upper surface 116, on opposite sides of bore 122. The identifier markings are intended to be visible in the resulting scan and provide dimensional and tolerance information concerning the given scan abutment 100. These markings are useful during the assigning step of the above described method in order to indicate which scan abutment (from a plurality of scan abutments) has been used.

[0084] It will be understood that the invention disclosed and defined in this specification extends to all alternative combinations of two or more of the individual features mentioned or evident from the text or drawings. All of these different combinations constitute various alternative aspects of the invention.

CLAIMS

1. An apparatus for facilitating the acquisition of a scan during an intraoral scanning procedure using an intraoral scanner, including: an elongate body having an attachment portion configured to attach the elongate body with an implant in a patient's mouth, the implant having a longitudinal axis, whereby the elongate body is adapted to extend substantially perpendicular to the longitudinal axis of the implant when mounted to the implant; the elongate body having a substantially planar upper surface and one or more side walls extending downwardly away from the upper surface; wherein the upper surface and the one or more side walls are observable in a resulting scan when the intraoral scanner scans the apparatus in a direction perpendicular to the upper surface.
2. The apparatus of claim 1, wherein the one or more side walls surround all or a substantial portion of the periphery of the upper surface, all being viewable from above the upper surface.
3. The apparatus of claim 1 or claim 2, wherein the one or more side walls taper inwardly towards the upper surface of the elongate body, thus providing a sloped skirt depending from the upper surface.
4. The apparatus of claim 3, wherein the side walls are inclined from the direction perpendicular to the upper surface by an angle between about 15° and about 40°.
5. The apparatus of any one of the preceding claims, wherein each of the one or more side walls is substantially planar.
6. The apparatus of any one of the preceding claims, wherein a plurality of side walls, defining a plurality of interconnected facets, is provided, each facet observable by the intraoral scanner when scanning in a direction substantially perpendicular to the upper surface.

7. The apparatus of claim 6, wherein the elongate body includes a first end and a second end, both ends having generally pointed end shapings, each defined by two meeting facets.
8. The apparatus of any one of the preceding claims, wherein the apparatus includes a fiducial marker mounted to or integral with the upper surface.
9. The apparatus of any one of the preceding claims, wherein the attachment portion is configured to receive a fastening element in order to fixedly attach the elongate body to the implant.
10. The apparatus of any one of the preceding claims, wherein the upper surface of the elongate body includes an aperture or recess configured to receive an indicator element that is identifiable in a resulting scan.
11. The apparatus of any one of the preceding claims, wherein one or more side walls adjacent the attachment portion include at least one cut-out portion configured to enable the scanner to retrieve data to assist in defining the longitudinal axis of the implant.
12. The apparatus of claim 11, wherein the cut-out portion(s) extend towards the attachment portion, thereby enabling visualisation of a surface of the attachment portion beneath the elongate body.
13. The apparatus of any one of the preceding claims, wherein one or more of the upper surface and side walls include an identifier which enables identification of the apparatus in a resulting scan.
14. The apparatus of claim 13, wherein the identifier indicates one or more of height, length, width or dimensional tolerance of the apparatus.
15. A method of performing an intraoral scanning procedure, including:
 - inserting one or more implants into a patient's jaw, each of the one or more implants having a longitudinal axis;
 - mounting the apparatus of any one of claims 1 to 14 to the one or more implants in the patient's mouth; and

scanning the apparatus and at least a part of the soft tissue in the patient's mouth, thereby producing a set of scan data for use in determining the relative position and orientation of the one or more implants relative to the soft tissue.

16. The method of claim 15, further including selecting one or more modular forms of said apparatus from a plurality of different modular forms of the apparatus, in order to best fit a space to be scanned in the patient's mouth.
17. The method of claim 15 or claim 16, further including, where a plurality of implants are inserted into the patient's jaw, mounting each apparatus to its respective implant in a way resulting in a substantial elongate overlap transition from each apparatus to each adjacent apparatus, across the space to be scanned.
18. A kit including a plurality of items of the apparatus of any one of claims 1 to 14, including items of different dimensions to each other, such that a plurality of items may be selected for a particular patient's mouth in accordance with the area of the patient's mouth to be scanned and/or in accordance with relative positions of one or more existing implants.
19. The kit of claim 18, wherein the different dimensions include different lengths, widths and/or different heights.
20. A method of performing an intraoral scanning procedure for determining the position and orientation of one or more implants in a patient's mouth, each implant having a longitudinal axis, the method using one or more scannable bodies and including:
 - providing a scannable body on each of the one or more implants, the scannable body extending substantially perpendicular to the longitudinal axis of the respective implant, the scannable body having a substantially planar first surface facing in a direction away from the soft tissue of the patient's mouth, and one or more further surfaces extending from the first surface, wherein the one or more further surfaces are viewable from a direction perpendicular to the first surface;

scanning the one or more scannable bodies, thereby producing a set of scan data associated with the intraoral scanning procedure;
assigning information from a set of stored data to the scan data; and
determining from the scan data and the assigned information the position and orientation of the one or more implants.

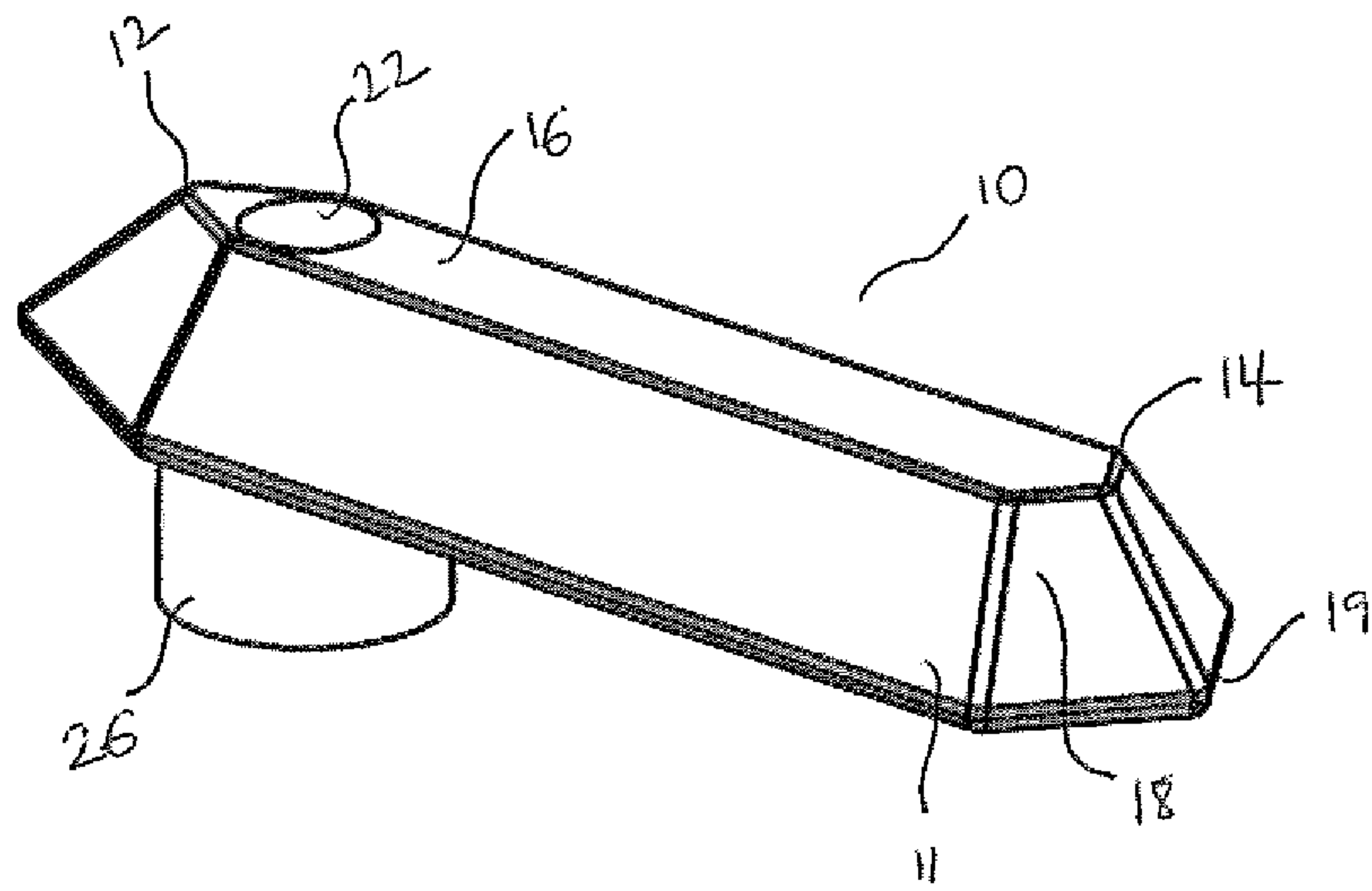

Figure 1

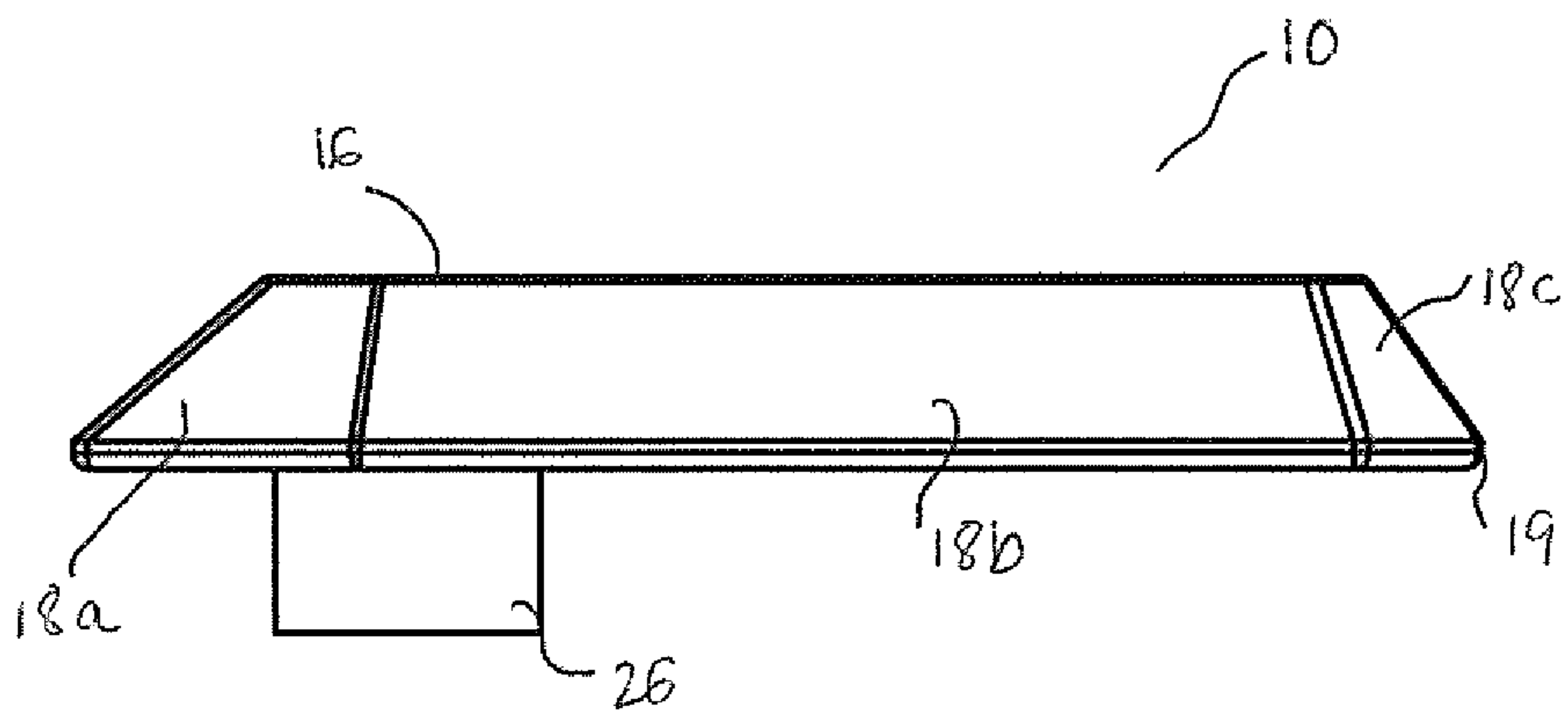

Figure 2

2/6

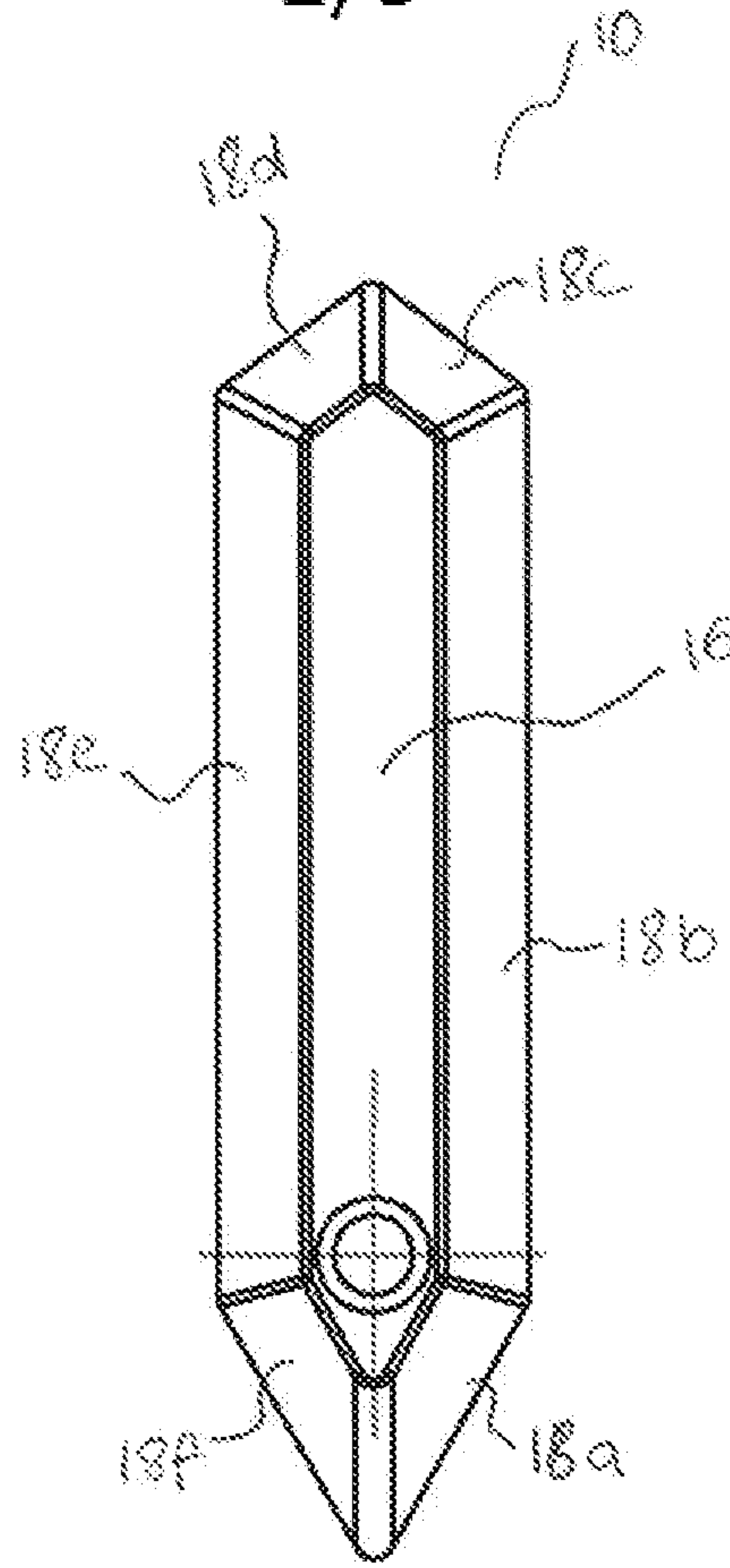

Figure 3

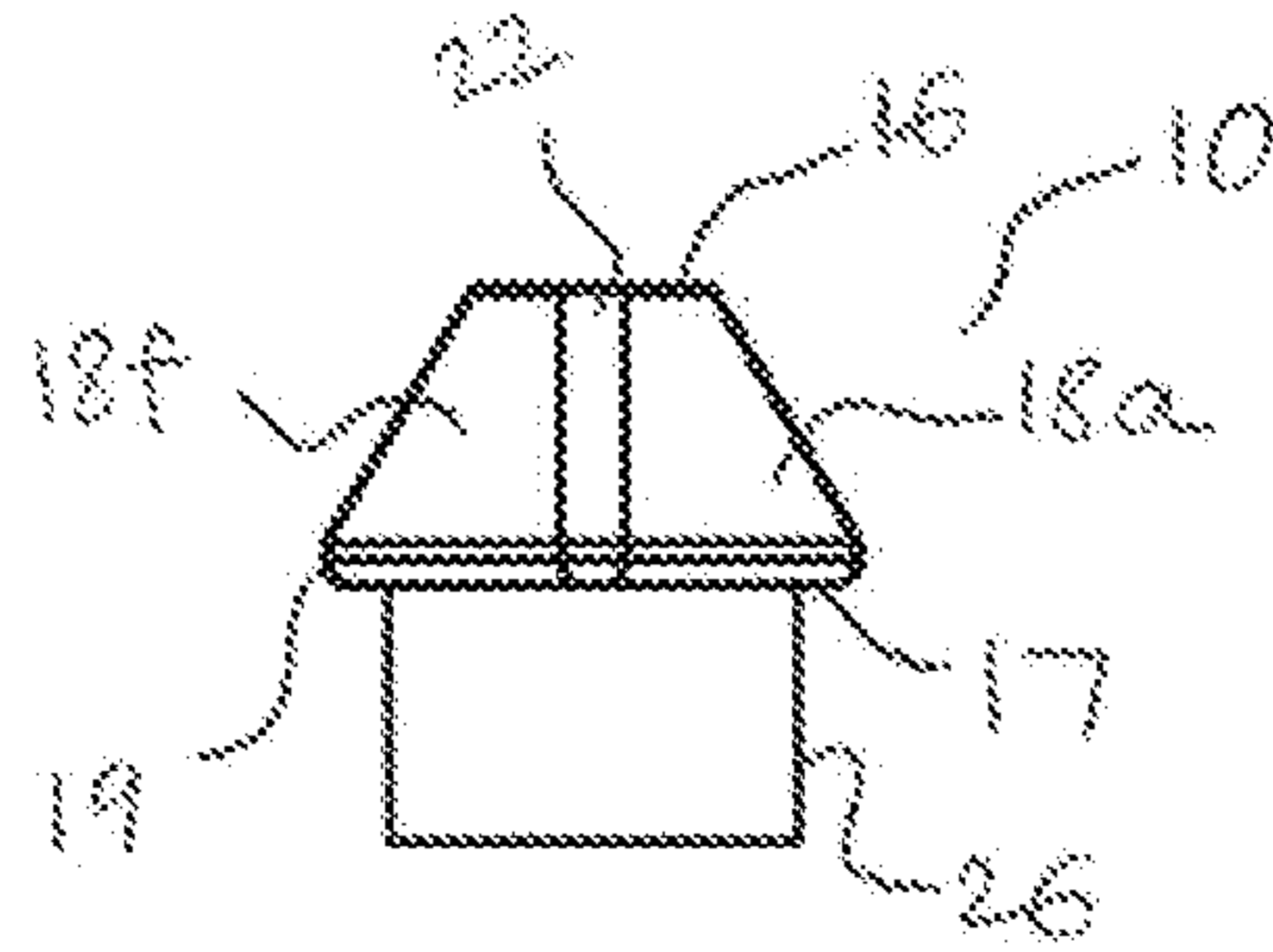

Figure 4

3/6

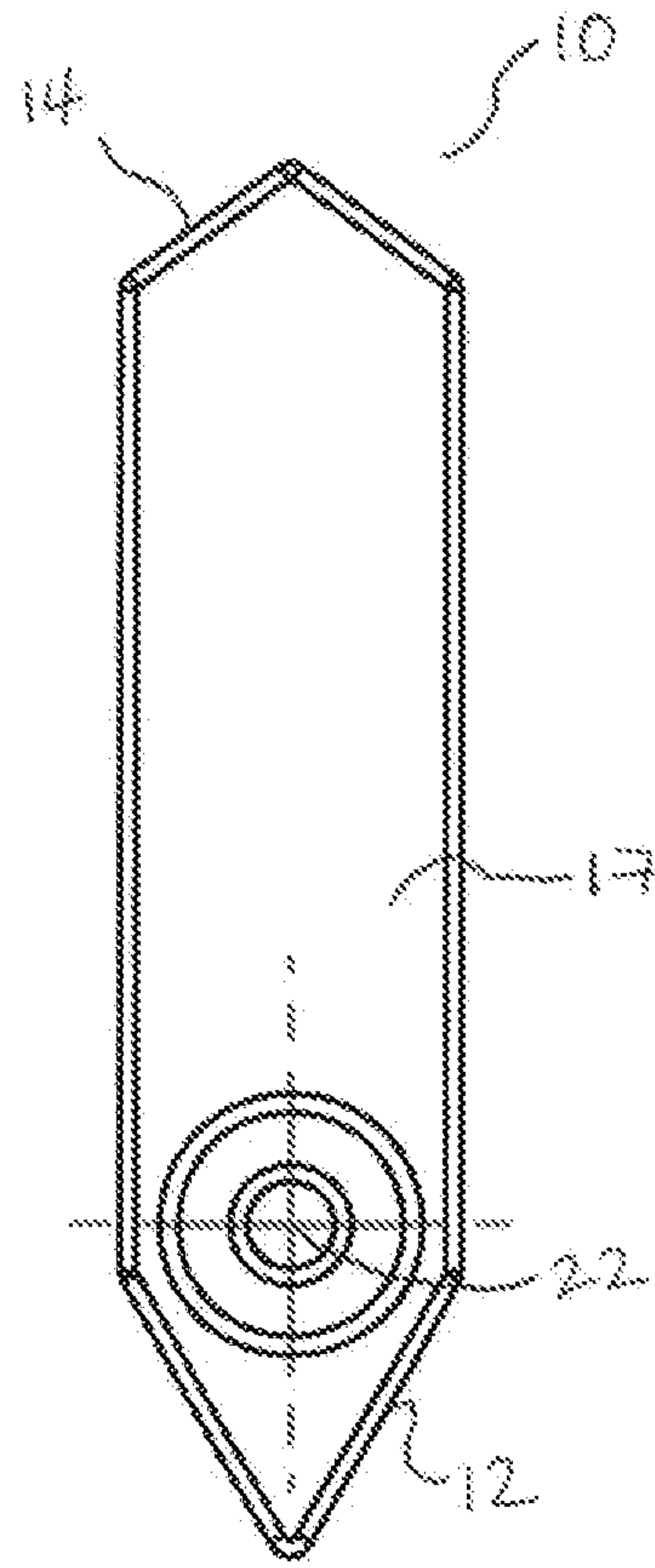

Figure 5

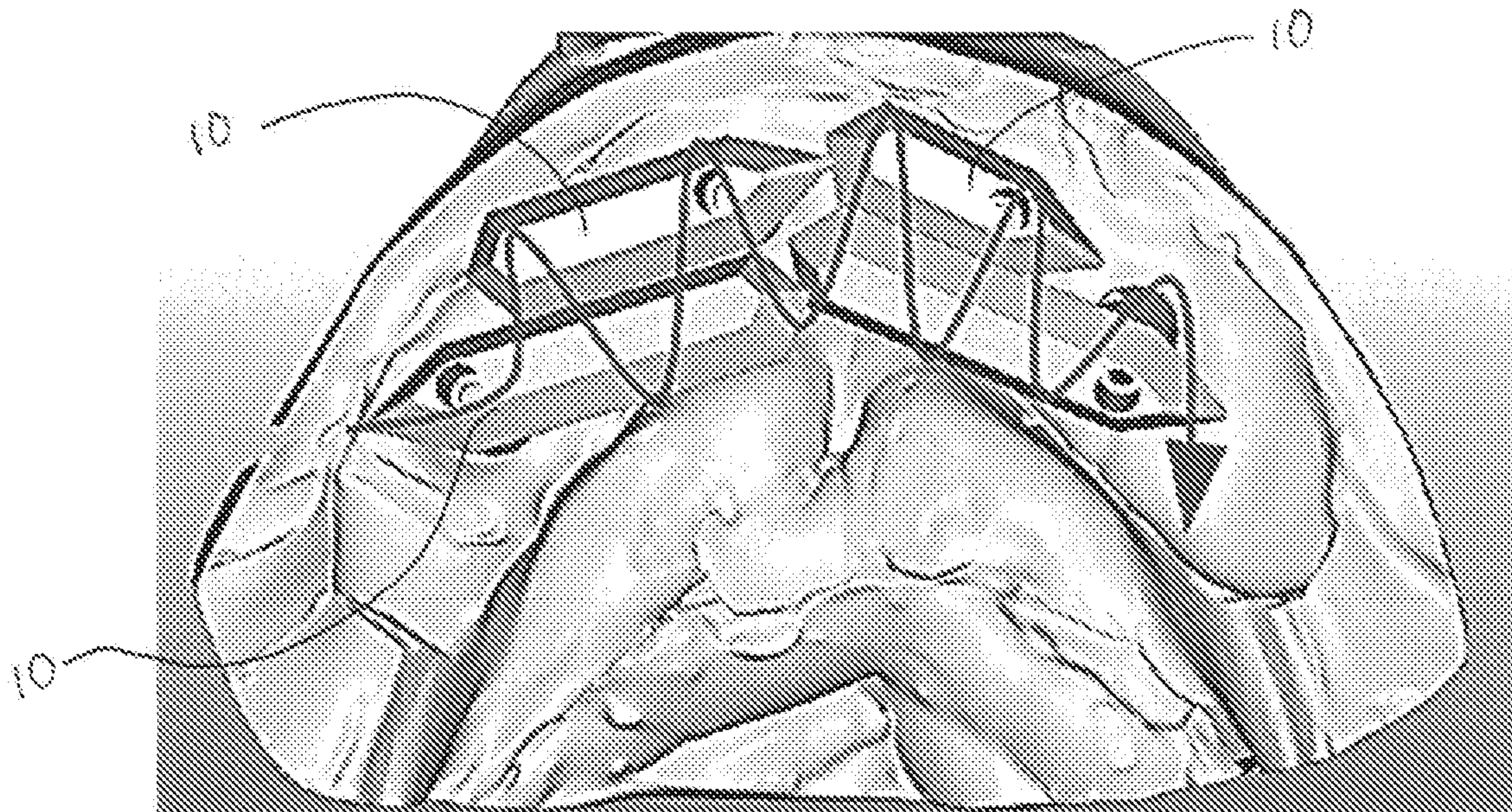

Figure 6

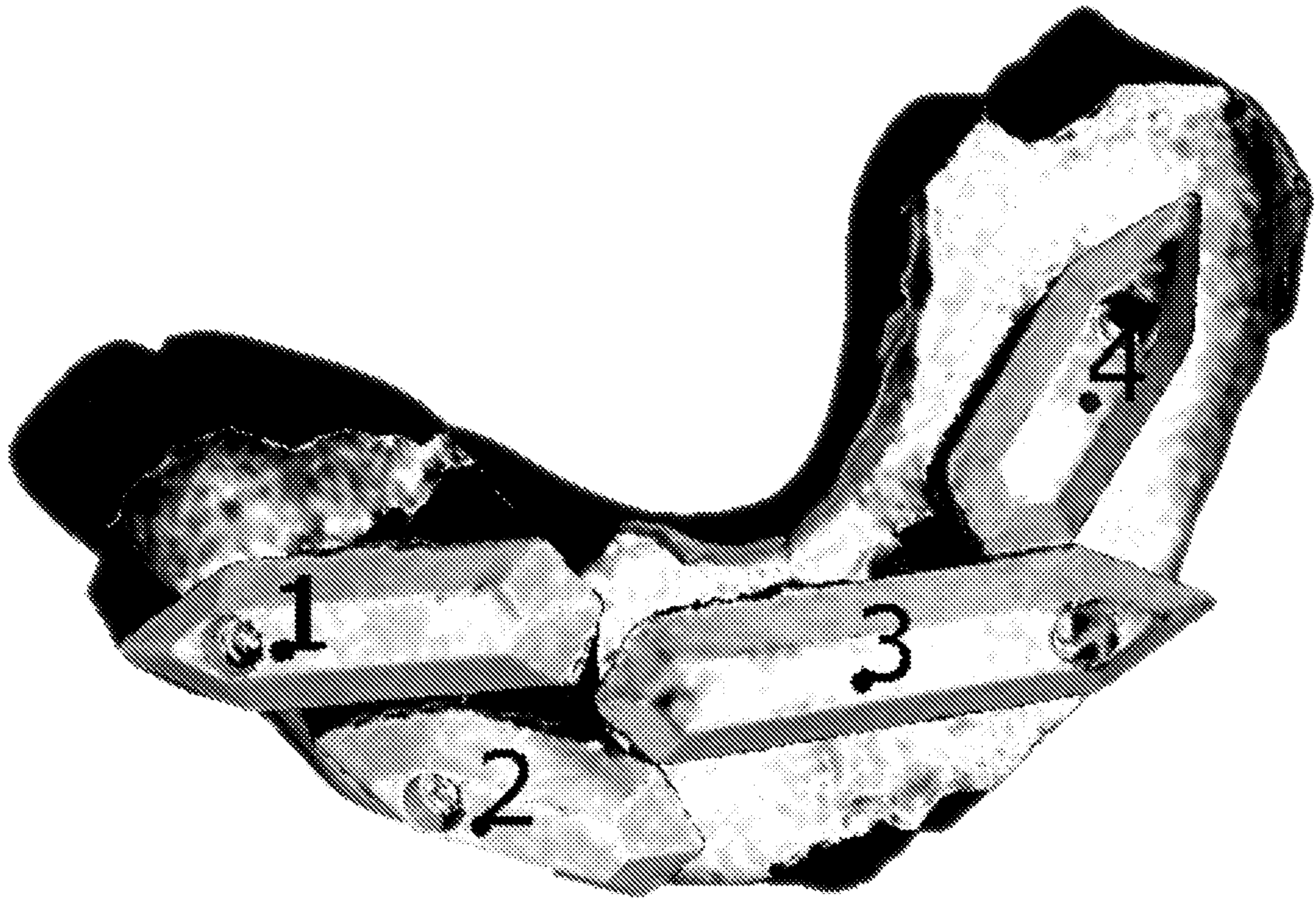

Figure 7

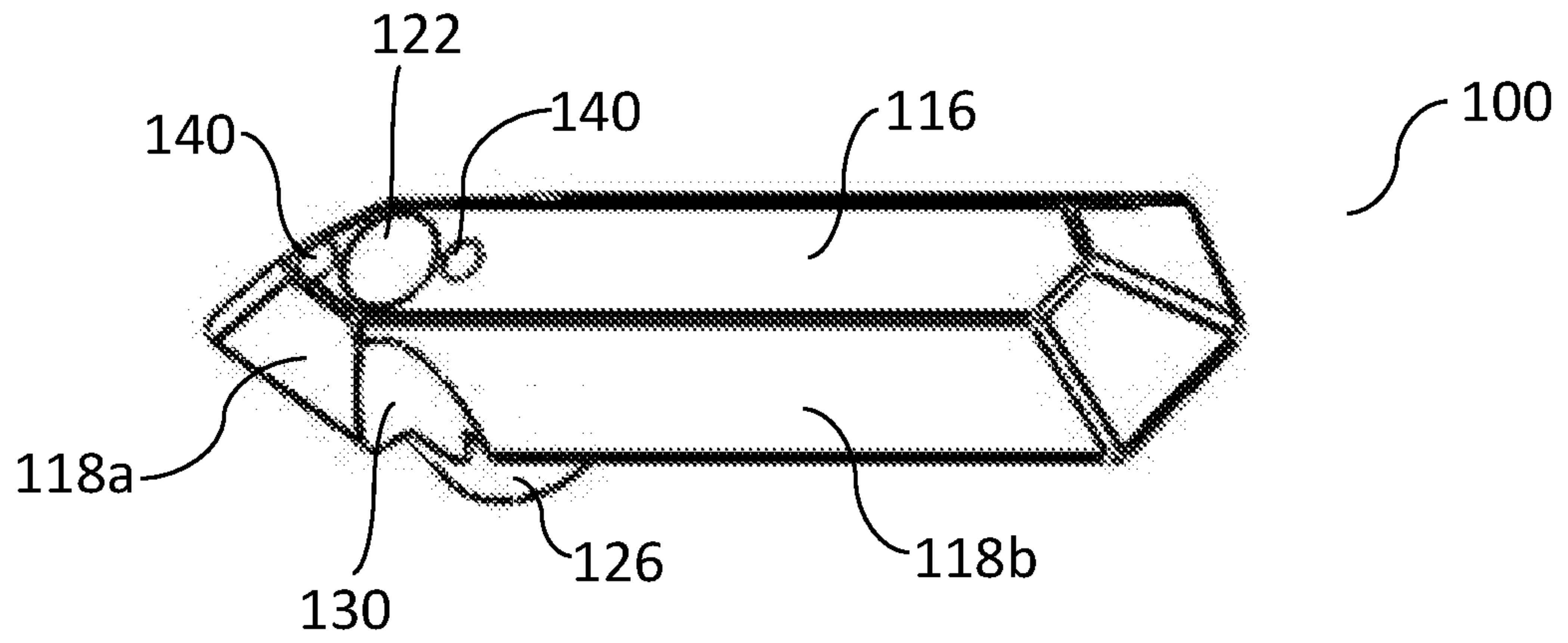

Figure 8

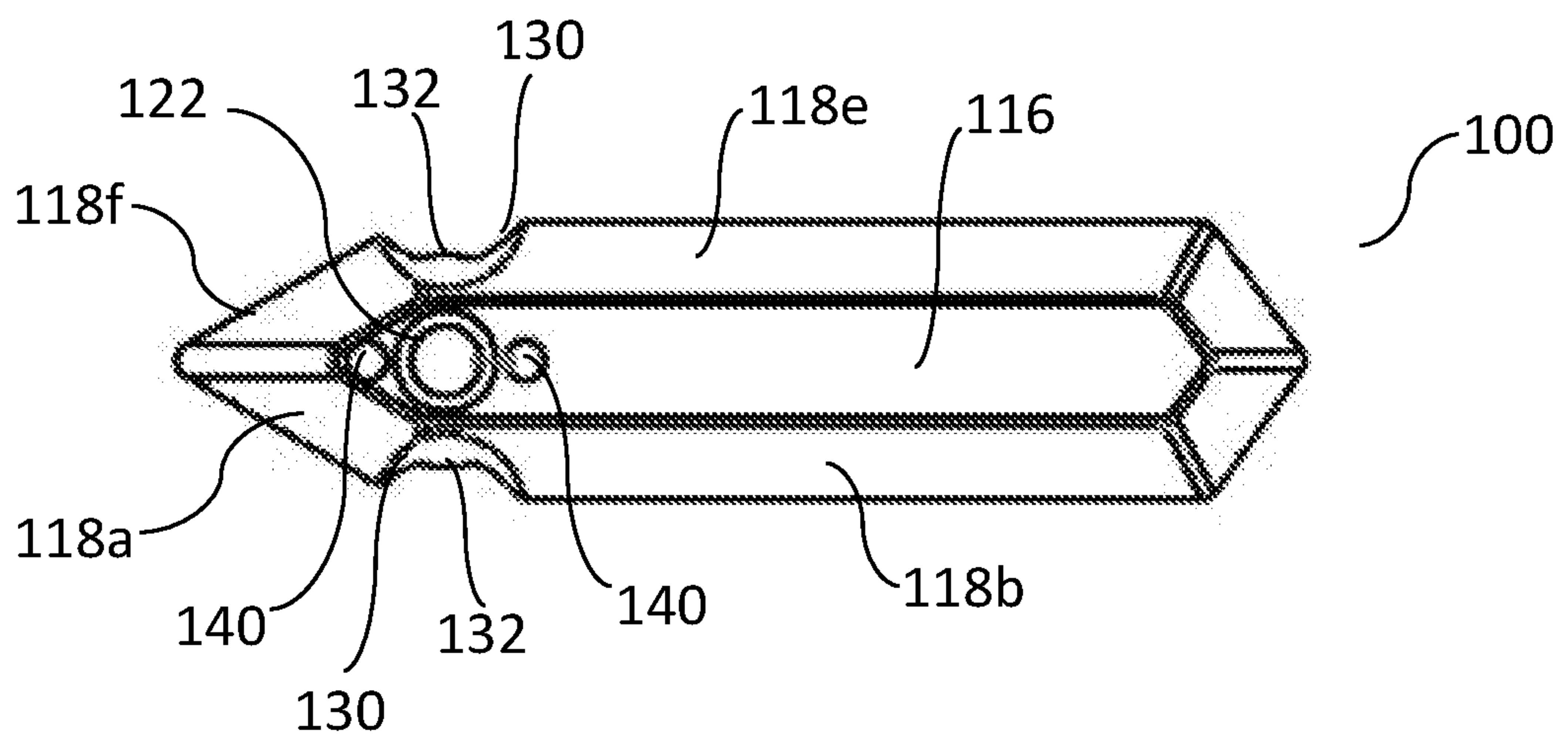

Figure 9

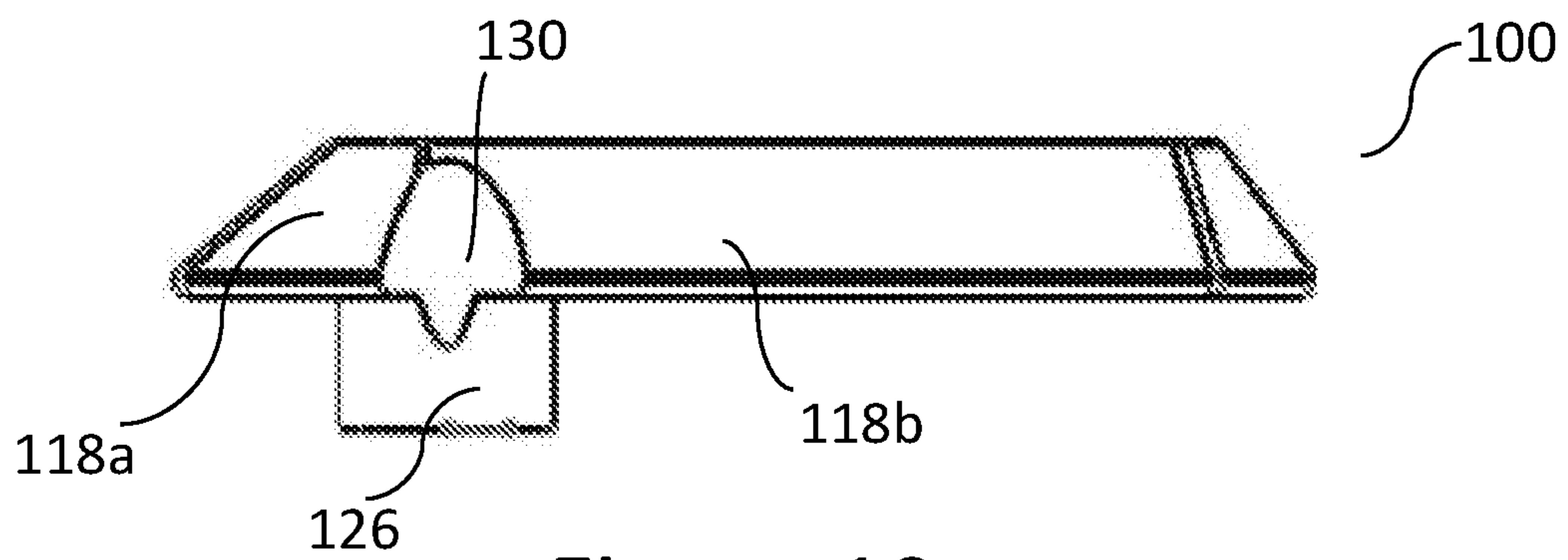

Figure 10

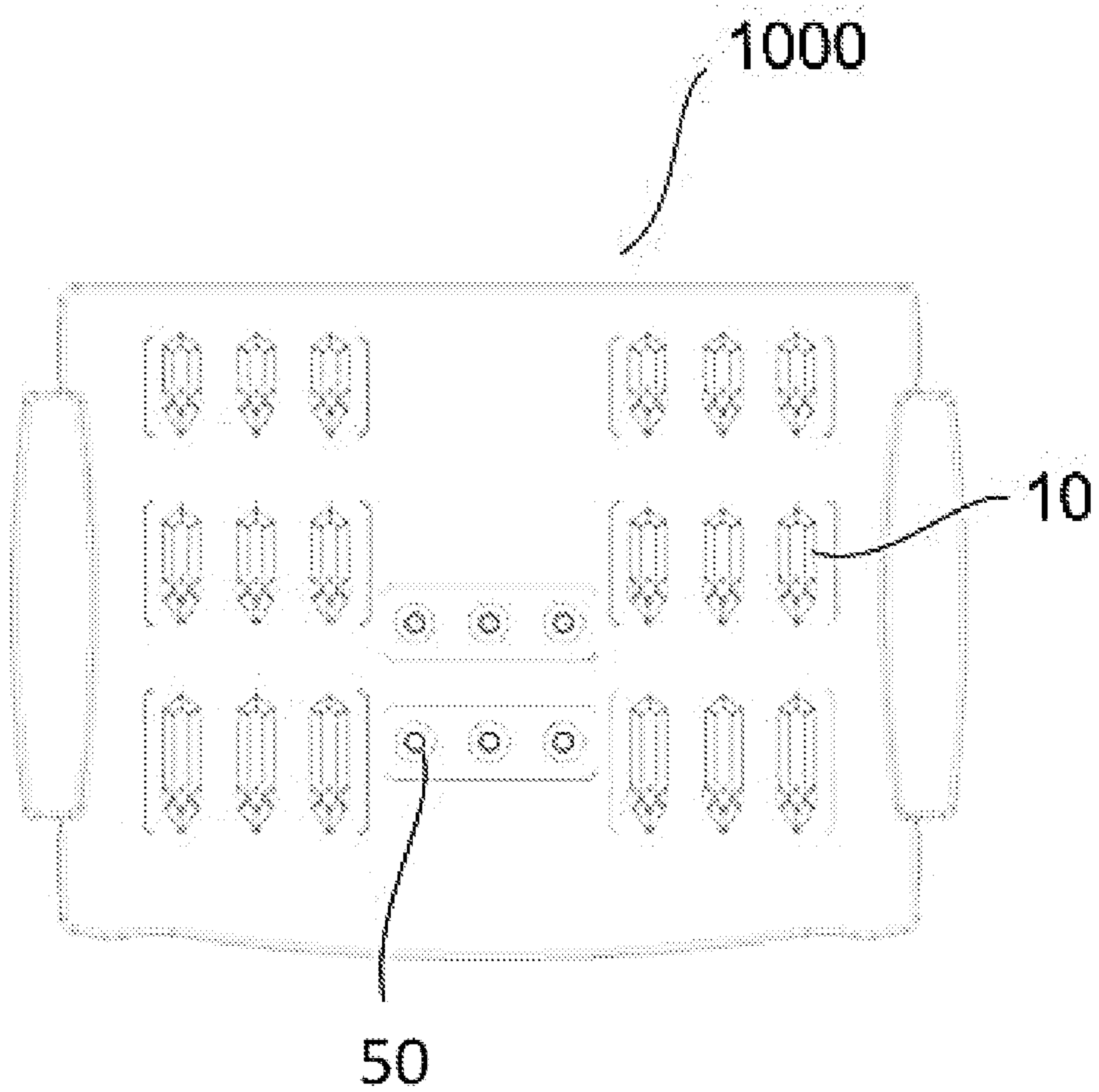

Figure 11

INTERNATIONAL SEARCH REPORT

International application No.
PCT/AU2020/051044

A. CLASSIFICATION OF SUBJECT MATTER

A61B 90/00 (2016.01) A61C 9/00 (2006.01)

According to International Patent Classification (IPC) or to both national classification and IPC

B. FIELDS SEARCHED

Minimum documentation searched (classification system followed by classification symbols)

Documentation searched other than minimum documentation to the extent that such documents are included in the fields searched

Electronic data base consulted during the international search (name of data base and, where practicable, search terms used)

PATENW and A61B5/0088, A61C9/0053/C, A61B1/24/C, A61B90/36/LOW and keywords: scan, hexagon, reference, skirt, bevel, plate and similar terms.

Espacenet: Applicant and inventor name searches.

C. DOCUMENTS CONSIDERED TO BE RELEVANT

Category*	Citation of document, with indication, where appropriate, of the relevant passages	Relevant to claim No.
	Documents are listed in the continuation of Box C	

 Further documents are listed in the continuation of Box C See patent family annex

* Special categories of cited documents:		
"A" document defining the general state of the art which is not considered to be of particular relevance	"T" later document published after the international filing date or priority date and not in conflict with the application but cited to understand the principle or theory underlying the invention	
"D" document cited by the applicant in the international application	"X" document of particular relevance; the claimed invention cannot be considered novel or cannot be considered to involve an inventive step when the document is taken alone	
"E" earlier application or patent but published on or after the international filing date	"Y" document of particular relevance; the claimed invention cannot be considered to involve an inventive step when the document is combined with one or more other such documents, such combination being obvious to a person skilled in the art	
"L" document which may throw doubts on priority claim(s) or which is cited to establish the publication date of another citation or other special reason (as specified)	"&" document member of the same patent family	
"O" document referring to an oral disclosure, use, exhibition or other means		
"P" document published prior to the international filing date but later than the priority date claimed		

Date of the actual completion of the international search
27 October 2020Date of mailing of the international search report
27 October 2020

Name and mailing address of the ISA/AU

AUSTRALIAN PATENT OFFICE
PO BOX 200, WODEN ACT 2606, AUSTRALIA
Email address: pct@ipaaustralia.gov.au

Authorised officer

David Melhuish
AUSTRALIAN PATENT OFFICE
(ISO 9001 Quality Certified Service)
Telephone No. +61262832426

INTERNATIONAL SEARCH REPORT		International application No. PCT/AU2020/051044
C (Continuation). DOCUMENTS CONSIDERED TO BE RELEVANT		
Category*	Citation of document, with indication, where appropriate, of the relevant passages	Relevant to claim No.
Y	US 2019/0290407 A1 (BIOMET 3I, LLC) 26 September 2019 paragraphs 45, 47 to 49, 51, figure 5B	1 - 11, 13 - 20
Y	US 2015/0196372 A1 (3DKREAFORM) 16 July 2015 paragraphs 99, 101, 102, figure 1	1 - 11, 13 - 20
Y	US 2017/0354483 A9 (STRAUMANN HOLDING AG) 14 December 2017 paragraph 25, figures 2a to 2e	1 - 11, 13 - 20
Y	US 2018/0325631 A1 (NOBEL BIOCARE SERVICES AG) 15 November 2018 paragraph 129, figure 8C	1 - 5, 8 - 11, 13 - 20
A	US 2016/0213442 A1 (ZFX GMBH) 28 July 2016	
A	US 2019/0117351 A1 (ZFX GMBH) 25 April 2019	
A	US 2010/0268071 A1 (KIM) 21 October 2010	
A	US 2010/0179420 A1 (ERNST) 15 July 2010 paragraphs 126 to 128, figure 4	7, 11

INTERNATIONAL SEARCH REPORT

Information on patent family members

International application No.

PCT/AU2020/051044

This Annex lists known patent family members relating to the patent documents cited in the above-mentioned international search report. The Australian Patent Office is in no way liable for these particulars which are merely given for the purpose of information.

Patent Document/s Cited in Search Report		Patent Family Member/s	
Publication Number	Publication Date	Publication Number	Publication Date
US 2019/0290407 A1	26 September 2019	US 2019290407 A1	26 Sep 2019
		AU 2013249682 A1	23 Oct 2014
		AU 2013249682 B2	26 Jul 2018
		CA 2869222 A1	24 Oct 2013
		EP 2838464 A1	25 Feb 2015
		EP 2838464 B1	11 Sep 2019
		JP 2015516856 A	18 Jun 2015
		JP 6389164 B2	12 Sep 2018
		US 2013273492 A1	17 Oct 2013
		US 9198627 B2	01 Dec 2015
		US 2016051346 A1	25 Feb 2016
		US 10350036 B2	16 Jul 2019
		WO 2013158432 A1	24 Oct 2013
		US 2015/0196372 A1	16 July 2015
BR 112015001819 A2	04 Jul 2017		
CA 2880281 A1	06 Feb 2014		
CN 104684484 A	03 Jun 2015		
EP 2879585 A1	10 Jun 2015		
FR 2994076 A1	07 Feb 2014		
FR 2994076 B1	30 Dec 2016		
JP 2015527129 A	17 Sep 2015		
RU 2015106983 A	20 Sep 2016		
WO 2014020247 A1	06 Feb 2014		
US 2017/0354483 A9	14 December 2017	US 2016296301 A1	13 Oct 2016
		US 10130446 B2	20 Nov 2018
		AU 2010213079 A1	25 Aug 2011
		AU 2010213079 B2	01 Nov 2012
		CA 2751203 A1	19 Aug 2010
		CN 102316821 A	11 Jan 2012
		CN 102316821 B	06 Aug 2014
		EP 2218423 A1	18 Aug 2010
		EP 2218423 B1	02 May 2012
		JP 2012517308 A	02 Aug 2012
		JP 5442036 B2	12 Mar 2014
		KR 20110114717 A	19 Oct 2011

Due to data integration issues this family listing may not include 10 digit Australian applications filed since May 2001.

Form PCT/ISA/210 (Family Annex)(July 2019)

INTERNATIONAL SEARCH REPORT

Information on patent family members

International application No.

PCT/AU2020/051044

This Annex lists known patent family members relating to the patent documents cited in the above-mentioned international search report. The Australian Patent Office is in no way liable for these particulars which are merely given for the purpose of information.

Patent Document/s Cited in Search Report**Patent Family Member/s****Publication Number****Publication Date****Publication Number****Publication Date**

KR 101306027 B1

12 Sep 2013

US 2012035889 A1

09 Feb 2012

WO 2010091868 A1

19 Aug 2010

Due to data integration issues this family listing may not include 10 digit Australian applications filed since May 2001.

Form PCT/ISA/210 (Family Annex)(July 2019)

INTERNATIONAL SEARCH REPORT

Information on patent family members

International application No.

PCT/AU2020/051044

This Annex lists known patent family members relating to the patent documents cited in the above-mentioned international search report. The Australian Patent Office is in no way liable for these particulars which are merely given for the purpose of information.

Patent Document/s Cited in Search Report		Patent Family Member/s	
Publication Number	Publication Date	Publication Number	Publication Date
US 2018/0325631 A1	15 November 2018	US 2018325631 A1	15 Nov 2018
		AU 2016356065 A1	12 Apr 2018
		BR 112018010171 A2	21 Nov 2018
		CA 3000913 A1	26 May 2017
		CN 108135676 A	08 Jun 2018
		EP 3376992 A1	26 Sep 2018
		EP 3376992 B1	08 Jan 2020
		JP 2018538014 A	27 Dec 2018
		KR 20180084890 A	25 Jul 2018
		WO 2017085288 A1	26 May 2017
		ZA 201801686 B	31 Jul 2019
US 2016/0213442 A1	28 July 2016	US 2016213442 A1	28 Jul 2016
		US 9993312 B2	12 Jun 2018
		AU 2014314612 A1	28 Jan 2016
		AU 2014314612 B2	30 Aug 2018
		CA 2917769 A1	05 Mar 2015
		CN 105473075 A	06 Apr 2016
		CN 105473075 B	26 Nov 2019
		EP 2842493 A1	04 Mar 2015
		EP 2842493 B1	06 Apr 2016
		JP 2016533824 A	04 Nov 2016
		JP 6276410 B2	07 Feb 2018
WO 2015028157 A1	05 Mar 2015		
US 2019/0117351 A1	25 April 2019	US 2019117351 A1	25 Apr 2019
		US 2014121500 A1	01 May 2014
		US 9554880 B2	31 Jan 2017
		US 2017119506 A1	04 May 2017
		US 10195003 B2	05 Feb 2019
US 2010/0268071 A1	21 October 2010	US 2010268071 A1	21 Oct 2010
		US 9008755 B2	14 Apr 2015
		CN 101902966 A	01 Dec 2010
		CN 101902966 B	24 Jul 2013
		EP 2233078 A1	29 Sep 2010
		JP 2009142561 A	02 Jul 2009

Due to data integration issues this family listing may not include 10 digit Australian applications filed since May 2001.

Form PCT/ISA/210 (Family Annex)(July 2019)

INTERNATIONAL SEARCH REPORT

Information on patent family members

International application No.

PCT/AU2020/051044

This Annex lists known patent family members relating to the patent documents cited in the above-mentioned international search report. The Australian Patent Office is in no way liable for these particulars which are merely given for the purpose of information.

Patent Document/s Cited in Search Report		Patent Family Member/s	
Publication Number	Publication Date	Publication Number	Publication Date
		JP 5250251 B2	31 Jul 2013
		KR 20100110785 A	13 Oct 2010
		WO 2009078424 A1	25 Jun 2009
US 2010/0179420 A1	15 July 2010	US 2010179420 A1	15 Jul 2010
		US 9222768 B2	29 Dec 2015
		EP 2175796 A2	21 Apr 2010
		JP 2010531192 A	24 Sep 2010
		WO 2009001298 A2	31 Dec 2008

End of Annex

Due to data integration issues this family listing may not include 10 digit Australian applications filed since May 2001.

Form PCT/ISA/210 (Family Annex)(July 2019)