

(12) INTERNATIONAL APPLICATION PUBLISHED UNDER THE PATENT COOPERATION TREATY (PCT)

(19) World Intellectual Property Organization
International Bureau



(43) International Publication Date

(10) International Publication Number

MEDICAL DEVICE RAPID DRUG RELEASING COATINGS COMPRISING A THERAPEUTIC AGENT AND A CONTRAST AGENT

CROSS REFERENCE TO RELATED APPLICATIONS

[001] This application is a continuation-in-part of Application No. 11/942,452, filed November 19, 2007, which claims the benefit of priority of U.S. Provisional Application No. 60/860,084, filed on November 20, 2006, U.S. Provisional Application No. 60/880,742, filed January 17, 2007, U.S. Provisional Application No. 60/897,427, filed on January 25, 2007, U.S. Provisional Application No. 60/903,529 filed on February 26, 2007, U.S. Provisional Application No. 60/904,473 filed March 2, 2007, U.S. Provisional Application No. 60/926,850 filed April 30, 2007, U.S. Provisional Application No. 60/981,380 filed October 19, 2007, and U.S. Provisional Application No. 60/981,384 filed October 19, 2007, the disclosures of all of which are incorporated by reference herein.

FIELD OF THE INVENTION

[002] Embodiments of the present invention relate to coated medical devices, and particularly to coated balloon catheters, and their use for rapidly delivering a therapeutic agent to particular tissue or body lumen, for treatment of disease and particularly for reducing stenosis and late lumen loss of a body lumen. Embodiments of the present invention also relate to methods of manufacturing these medical devices, the drug releasing coatings of therapeutic agent and contrast agent provided on these medical devices, the solutions for making those coatings, and methods for treating a body lumen such as the vasculature, including particularly arterial vasculature, for example, using these coated medical devices.

BACKGROUND OF THE INVENTION

[003] It has become increasingly common to treat a variety of medical conditions by introducing a medical device into the vascular system or other lumen within a human or veterinary patient such as the esophagus, trachea, colon, biliary tract, or urinary tract. For example, medical devices used for the treatment of vascular disease include stents, catheters, balloon catheters, guide wires, cannulas and the like. While these medical devices initially appear successful, the benefits are often compromised by the occurrence of complications, such as late

thrombosis, or recurrence of disease, such as stenosis (restenosis), after such treatment.

[004] Restenosis, for example, involves a physiological response to the vascular injury caused by angioplasty. Over time, de-endothelialization and injury to smooth muscle cells results in thrombus deposition, leukocyte and macrophage infiltration, smooth muscle cell proliferation/migration, fibrosis and extracellular matrix deposition. Inflammation plays a pivotal role linking early vascular injury to the eventual consequence of neointimal growth and lumen compromise. In balloon-injured arteries, leukocyte recruitment is confined to early neutrophil infiltration, while in stented arteries, early neutrophil recruitment is followed by prolonged macrophage accumulation. The widespread use of coronary stents has altered the vascular response to injury by causing a more intense and prolonged inflammatory state, due to chronic irritation from the implanted foreign body, and in the case of drug eluting stents (DES), from insufficient biocompatibility of the polymer coating.

[005] Over the past several years, numerous local drug delivery systems have been developed for the treatment and/or the prevention of restenosis after balloon angioplasty or stenting. Examples include local drug delivery catheters, delivery balloon catheters, and polymeric drug coated stents. Given that many diseases affect a specific local site or organ within the body, it is advantageous to preferentially treat only the affected area. This avoids high systemic drug levels, which may result in adverse side effects, and concentrates therapeutic agents in the local area where they are needed. By treating just the diseased tissue, the total quantity of drug used may be significantly reduced. Moreover, local drug delivery may allow for the use of certain effective therapeutic agents, which have previously been considered too toxic or non-specific to use systemically.

[006] One example of a local delivery system is a drug eluting stent (DES). The stent is coated with a polymer into which drug is impregnated. When the stent is inserted into a blood vessel, the polymer degrades and the drug is slowly released. The slow release of the drug, which takes place over a period of weeks to months, has been reported as one of the main advantages of using DES. However, while slow release may be advantageous in the case where a foreign body, such as a stent, is deployed, which is a source of chronic irritation and inflammation, if a foreign body is not implanted it is instead advantageous to rapidly

deliver drug to the vascular tissue at the time of treatment to inhibit inflammation and cellular proliferation following acute injury. Thus, a considerable disadvantage of a DES, or any other implanted medical device designed for sustained release of a drug, is that the drug is incapable of being rapidly released into the vessel.

[007] Additionally, while drug-eluting stents were initially shown to be an effective technique for reducing and preventing restenosis, recently their efficacy and safety have been questioned. A life-threatening complication of the technology, late thrombosis, has emerged as a major concern. Drug eluting stents cause substantial impairment of arterial healing, characterized by a lack of complete re-endothelialization and a persistence of fibrin when compared to bare metal stents (BMS), which is understood to be the underlying cause of late DES thrombosis. Concerns have also been raised that the polymeric matrix on the stent in which the anti-proliferative drug is embedded might exacerbate inflammation and thrombosis, since the polymers used are not sufficiently biocompatible. These polymeric systems are designed to facilitate long-term sustained release of drug over a period of days, months, or years, not over a period of seconds or minutes. These polymeric drug coatings of medical devices do not release the polymer, which remains on the device even after drug is released. Even if biodegradable polymers are used, polymer and drug are not released at the same time. Rapid release of drug, an intent of embodiments of the present invention, from these polymeric systems is not possible. Thus, combining a therapeutic agent with a polymer in a medical device coating may have significant disadvantages.

[008] Another important limitation of the DES is that the water insoluble drugs are not evenly distributed in the polymeric matrix of the coating. Furthermore, drug and polymer are concentrated on the struts of the stent, but not in gaps between the struts. The non-uniform distribution of drug causes non-uniform drug release to the tissue of the vessel walls. This may cause tissue damage and thrombosis in areas exposed to excess drug and hyperplasia and restenosis areas that are undertreated. Thus, there is a need to improve the uniformity of drug delivery to target tissues by improving drug solubility in coatings of medical devices by increasing the drug's compatibility with carriers in the coatings, such as a polymeric matrix, thereby eliminating or reducing the size of

drug crystal particles in the polymeric matrix or other coating to create a uniform drug distribution in the drug coating on the medical device.

[009] Yet another important limitation of the DES is that only a limited amount of an active agent can be loaded into the relatively small surface area of the stent.

[010] Non-stent based local delivery systems, such as balloon catheters, have also been effective in the treatment and prevention of restenosis. The balloon is coated with an active agent, and when the blood vessel is dilated, the balloon is pressed against the vessel wall to deliver the active agent. Thus, when balloon catheters are used, it is advantageous for the drug in the coating to be rapidly released and absorbed by blood vessel tissues. Any component of the coating that inhibits rapid release, such as a crosslinked polymer, liposome, or encapsulating particle, is necessarily disadvantageous to the intended use of the balloon catheter, which is inflated for a very brief period of time and then removed from the body.

[011] Hydrophilic drugs, such as heparin, have been reported to be deliverable by polymeric hydrogel coated balloon catheters. However, a polymeric hydrogel coating can not effectively deliver water insoluble drugs (such as paclitaxel and rapamycin), because they can not mix with the hydrogel coating. Furthermore, the cross-linked polymeric hydrogel remains on the balloon after drug is released

[012] Alternatively, balloon catheters are reported to have been coated with hydrophobic therapeutic agents that have been encapsulated in particles such as micelles, liposomes, nanoparticles or polymers. Liposomes, which usually contain a core of aqueous solution, and micelles, which do not, have both been reported to be useful for pharmaceutical preparations of water-insoluble drugs for venous injection. However, for purposes of a medical device coating, all of these drug delivery formulations have significant disadvantages: drug loading is poor, and drug release from these preparations is slow.

[013] Oils and lipids mix well with water-insoluble drugs such as paclitaxel or rapamycin, but when micelles or liposomes are then formed by interaction with aqueous media, the particles and particle sizes are relatively unstable, ranging in a broad particle size distribution from several hundred nanometers to several microns in diameter. Several reports suggest that the maximal concentration ratio of drug to

lipid that can be stably achieved in these particles is in the range of 0.2 to 0.3; it is often less than 0.1.

[014] Another disadvantage of oil-based liposome formulations is the dependence of drug absorption on the rate and extent of lipolysis. Lipolysis of oil-based triglycerides is difficult and dependent upon many factors, and triglycerides must be digested and drug released in order to be absorbed by diseased tissue. The amount of hydrophobic drug delivered to tissues by these agents will be low, because liposomes and micelles cannot efficiently release hydrophobic drug, which they carry away before it can be absorbed by tissues. Micelles, liposomes, or particles of oils and lipids are therefore not effective at rapidly and efficiently facilitating tissue uptake of drug during a very brief device deployment time, and no report has shown these types of coatings to be effective.

[015] Loading capacity of conventional micelles and liposomes is low. In the absence of other considerations, the highest achievable drug to lipid ratio is advantageous, since high lipid doses may raise concerns of toxicity, and it is the drug—not the lipid—that provides the therapeutic benefit, once it is delivered to target tissue. The ratio of drug to lipid in these formulations is often less than 0.1 and almost always less than 0.2-0.3, because a significantly higher concentration of lipid than drug is required in order for the drug to be encapsulated in the particles, micelles, or liposomes. Formulation stability is highly dependent on drug-lipid interactions that are concentration dependent. "In many studies, a maximum of 3 to 4 mol% drug (with respect to phospholipid) possess stability of sufficient duration as to be clinically useable. 8 mol% paclitaxel liposomes may be physically stable for 15 min or less"-Preparation and Characterization of Taxane-Containing Liposomes. *Methods Enzymol.* 2005; 391:97-117, p.101-2. Several attempts to achieve drug to lipid concentration ratios higher than 0.2 – 0.3 failed (for example, see *PDA J Pharm Sci Technol* 2006 60(3):144-55). These technologies involve forming the drug/lipid particles first and then coating medical devices with the prepared particles. Liposomes, for example, are prepared by first mixing drug and lipid in organic solvent, then removing the organic solvent to form a lipid film or cake, then hydrating with aqueous solution and sonicating.

[016] There are several reports showing that drug release from liposomal, miscellar, or particular oil/lipid formulations occurs very slowly, in the range of days

to weeks or months. In addition, the inventor has found that drug release occurs far too slowly from a coating consisting essentially of just oil/lipid and lipophilic drug, because they bind to each other and to the external surface of the medical device so tightly that the drug cannot rapidly elute off the device during several minutes or less of deployment at the target site. This slow-releasing property of prior approaches to drug:oil, drug:fatty acid, and drug:lipid formulations is not desirable in embodiments of the present inventions, wherein drug release takes place in the range of seconds to minutes. Thus the technology for oil/lipid formulation needs to be improved significantly in order to be useful in the rapid drug release coatings for medical devices of the present invention.

[017] Drug that is encapsulated in polymeric particles may take even longer to diffuse from the coating (the reported range is months to years) and will have further difficulty permeating target tissues rapidly. Microspheres formed with polymeric materials, such as polyesters, when used to encapsulate water insoluble drugs, are unable to release the drug until the polymeric material is degraded. Thus, these polymeric microspheres are useful for sustained release of drug over a long period of time but cannot rapidly release drug and facilitate tissue uptake.

[018] The iodine contrast agent iopromide has been used with paclitaxel to coat balloon catheters and has had some variable success in the treatment of restenosis. Notwithstanding this result, prior approaches to coating formulations with iodine contrast agent and a lipophilic or water-insoluble therapeutic agent have serious drawbacks. The physical characteristics of these coatings are very poor. There is a several-fold variability in drug levels in tissue after treatment, which results in inconsistent therapeutic outcomes.

[019] Experimentally, the present inventor has found that the compatibility or miscibility of lipophilic or water-insoluble therapeutic agents and iodine contrast agents is not good, and the integrity and uniformity of the coating is very poor. Particles from the coating easily flake off and are lost during handling. When the coating consists essentially of iopromide and paclitaxel, for example, there is experimentally several-fold variability in drug concentration distribution on the surface of the medical device. Furthermore, there is marked variability in adhesion of drug to the surface of the device, and clumps of contrast agent and drug of variable size are formed that easily flake off the device during minimal

handling in the interventional cardiology suite. These deficiencies adversely affect the consistency and uniformity of drug delivery to target tissues, which results in highly variable and inconsistent therapeutic effects and decreased therapeutic utility of the coated device. Improved coatings are therefore needed, coatings that maintain integrity during handling and more effectively and uniformly deliver drug and facilitate its absorption by tissue.

[020] Thus, the technology for formulating coatings of contrast agent and drug needs to be improved significantly in order to achieve consistent therapeutic results and to improve the clinical utility of the rapid drug release coatings for medical devices.

[021] Combining drugs and medical devices is a complicated area of technology. It involves the usual formulation challenges, such as those of oral or injectable pharmaceuticals, together with the added challenge of maintaining drug adherence to the medical device until it reaches the target site and subsequently delivering the drug to the target tissues with the desired release and absorption kinetics. Drug coatings of medical devices must also have properties such that they do not crack upon expansion and contraction of the device, for example, of a balloon catheter or a stent. Furthermore, coatings must not impair functional performance such as burst pressure and compliance of balloons or the radial strength of self- or balloon-expanded stents. The coating thickness must also be kept to a minimum, since a thick coating would increase the medical device's profile and lead to poor trackability and deliverability. These coatings generally contain almost no liquid chemicals, which typically are often used to stabilize drugs. Thus, formulations that are effective with pills or injectables might not work at all with coatings of medical device. If the drug releases from the device too easily, it may be lost during device delivery before it can be deployed at the target site, or it may burst off the device during the initial phase of inflation and wash away before being pressed into contact with target tissue of a body lumen wall. If the drug adheres too strongly, the device may be withdrawn before the drug can be released and absorbed by tissues at the target tissues.

[022] Thus, there is still a need to develop improved coatings of therapeutic agent and contrast agent for medical devices that rapidly, uniformly, and consistently deliver therapeutic agent directly into a localized tissue area during or

following a medical procedure, during a brief 0.1 to 2 minute deployment of the device at the target site, so as to treat or prevent vascular and nonvascular diseases such as stenosis. There is still a need to develop coatings with improved compatibility of contrast agent and lipophilic or water insoluble drug. There is still a need to develop coatings that preserve coating integrity and uniformity of drug distribution and that diminish the propensity for particles to flake off from the coating during handling. And there is still a need to develop coatings of contrast agent and drug that result in more uniform and consistent delivery of drug to target tissue.

[023] Thus, the technology for formulating medical device coatings of contrast agent and therapeutic agent needs to be improved significantly in order to achieve consistent therapeutic results and to improve the clinical utility of the coated medical devices, which is an object of embodiments of the present invention.

SUMMARY OF THE INVENTION

[024] The present inventor has found that coating the exterior surface of a medical device, and particularly of a balloon catheter or a stent, for example, with a layer comprising a lipophilic or water-insoluble therapeutic agent, a contrast agent, and an additive that has both a hydrophilic part and a drug affinity part is useful in solving the problems associated with the coatings discussed above. The drug affinity part is a hydrophobic part and/or has an affinity to the therapeutic agent by hydrogen bonding and/or van der Waals interactions. The hydrophilic part has a very good compatibility or miscibility with the hydrophilic contrast agent. In some embodiments, the additive includes surfactants. In embodiments of the present invention, the surfactant is an ionic or non-ionic surfactant. In another embodiment, the surfactant is an aliphatic or aromatic surfactant.

[025] Surprisingly, the present inventor has found that the at least one additive according to embodiments of the present invention, which comprises a hydrophilic part and a drug affinity part, in combination with a lipophilic or water-insoluble therapeutic agent and a contrast agent, forms an effective drug delivery coating on a medical device that avoids the disadvantages of conventional liposomal or encapsulation based coating formulations such as slow release, lipolysis dependence, and a very low limit to drug:lipid concentration ratio. Moreover, the coatings according to embodiments of the present invention avoid

the disadvantages of prior formulation technologies for coatings of contrast agent and lipophilic or water-insoluble drug, such as the inability to preserve coating integrity and uniformity of drug distribution, and the unavoidable flaking off of particles from the coating during handling.

[026] The present inventor has also found that coating the exterior surface of a medical device, and particularly of a balloon catheter or a stent, for example, with a layer comprising a lipophilic or water-insoluble therapeutic agent, a contrast agent, and one of an oil, a fatty acid, and a lipid, wherein the therapeutic agent is not enclosed in liposomes or particles, is also useful in solving the problems associated with the coatings discussed above.

[027] The coatings according to embodiments of the present invention have improved resistance to mechanical disruption, improved preservation of coating integrity and uniformity of drug distribution, and diminished propensity for coating particles to flake off during handling of the device.

[028] The coatings according to embodiments of the present invention also facilitate rapid, uniform, and consistent drug elution off of the surface of the device and superior permeation of drug into tissues at a disease site to treat disease. For example, to treat stenosis and to reduce restenosis and late lumen loss of a body lumen. Thus, coatings according to embodiments of the present invention provide an enhanced rate and/or consistency and/or uniformity and/or extent of absorption of the lipophilic or water-insoluble therapeutic agent in diseased tissues of the vasculature or other body lumen.

[029] In embodiments of the present invention, the coated device is for reducing stenosis and late lumen loss of a body lumen.

[030] In embodiments of the present invention, the coated device improves consistency or decreases variability of drug uptake by tissue. In embodiments of the present invention, the coated device improves consistency or decreases variability of the therapeutic outcome or clinical result of the treatment.

[031] In one embodiment, the present invention relates to a medical device for delivering a therapeutic agent to a tissue for reducing stenosis and late lumen loss of a body lumen, the device comprising a layer overlying an exterior surface of the medical device. The device includes one of a balloon catheter, a perfusion balloon catheter, an infusion catheter such as distal perforated drug

infusion tube, a perforated balloon, spaced double balloon, porous balloon, and weeping balloon, a cutting balloon catheter, a scoring balloon catheter, a laser catheter, an atherectomy device, a debulking catheter, a stent, a filter, a stent graft, a covered stent, a patch, a wire, and a valve. Further, the tissue includes tissue of one of coronary vasculature, peripheral vasculature, cerebral vasculature, esophagus, airways, sinus, trachea, colon, biliary tract, urinary tract, prostate, and brain passages.

[032] In one embodiment of the medical device, the layer overlying the exterior surface of the medical device comprises a therapeutic agent, a contrast agent and an additive, wherein the contrast agent is chosen from iobitridol, iohexol, iomeprol, iopamidol, iopentol, iopromide, ioversol, ioxilan, iotrolan, iodixanol, ioxaglate, and their derivatives.

[033] In one embodiment of the medical device, the layer overlying the exterior surface of the medical device comprises a lipophilic or water-insoluble therapeutic agent, a contrast agent, and one of an oil, a fatty acid, and a lipid. In one embodiment, the therapeutic agent is not encapsulated in liposomes or particles.

[034] In one embodiment of the medical device, the layer overlying the exterior surface of the medical device comprises a lipophilic or water-insoluble therapeutic agent, a contrast agent, and an additive, wherein the additive has both a hydrophilic part and a drug affinity part, wherein the drug affinity part is at least one of a hydrophobic part, a part that has affinity to the therapeutic agent by hydrogen bonding and/or charge and/or van der Waals interactions.

[035] In one embodiment the present invention relates to a medical device for delivering a therapeutic agent to a tissue, the device comprising a layer overlying the exterior surface of the medical device, the layer comprising a lipophilic or water-insoluble therapeutic agent, a contrast agent, and an additive, wherein the additive comprises a hydrophilic part and a drug affinity part, wherein the drug affinity part is a hydrophobic part, a part that has an affinity to the therapeutic agent by hydrogen bonding, and a part that has an affinity to the therapeutic agent by van der Waals interactions, wherein the additive is water-soluble, and wherein the additive is at least one of a surfactant and a chemical compound. In one embodiment, the surfactant improves compatibility and miscibility of the lipophilic or

water-insoluble drug and the hydrophilic contrast agent. In one embodiment, the layer overlying the exterior surface of the medical device consists essentially of the therapeutic agent, the contrast agent, and the additive.

[036] In one embodiment, the layer overlying the exterior surface of the medical device includes the therapeutic agent, a contrast agent, and an additive, but does not include a polymer.

[037] In one embodiment, the additive in the layer comprising the therapeutic agent, a contrast agent, and an additive is an ionic or non-ionic surfactant. In another embodiment, the additive is an aliphatic or aromatic surfactant. In another embodiment, the additive is a chemical compound with one or more hydroxyl, amino, carbonyl, carboxyl, acid, amide, ester moieties thereof.

[038] In another embodiment, the additive is a chemical compound with one or more hydroxyl, amino, carbonyl, carboxyl, acid, amide, or ester moieties with a molecular weight of less than 5,000-10,000, preferably less than 1000-5,000, more preferably less than 750-1,000, or most preferably less than 750. In this embodiment, molecular weight of the additive is preferred to be less than that of the drug to be delivered. Small molecules can diffuse quickly, and they easily release from the surface of the delivery balloon, carrying drug with them. They quickly diffuse away from drug when the drug binds tissue. The molecular weight of the additives can not be too low, however; additives with molecular weight less than 80 are not desirable because they evaporate easily and are not stable components of the coating. In another embodiment, the additive is hydroxyl ketone, hydroxyl lactone, hydroxyl acid, hydroxyl ester, or hydroxyl amide. In another embodiment, the additive is gluconolactone or ribonic acid lactone thereof. In yet another embodiment, the additive is chosen from meglumine/lactic acid, meglumine/gentisic acid, meglumine/acetic acid, lactobionic acid, Tween 20/sorbitol, Tween 20/lactobionic acid, Tween 20/sugar or sugar derivatives. and N-octanoyl N-methylglucamine. In another embodiment, the additive is a vitamin or derivative thereof. In another embodiment, the additive is an amino acid or derivative thereof. In another embodiment, the additive is a protein or derivative thereof. In another embodiment, the additive is an albumin

[039] In one embodiment, the layer overlying the exterior surface of the medical device does not include an oil, a lipid, or a polymer. In another

embodiment, the layer overlying the exterior surface of the medical device does not include an oil. In another embodiment, the layer overlying the exterior surface of the medical device does not include a polymer. In another embodiment, the layer overlying the exterior surface of the medical device does not include a purely hydrophobic additive. In another embodiment, the layer overlying the exterior surface of the medical device does not include salicylic acid or salts thereof. In yet another embodiment, the layer overlying the exterior surface of the medical device does not include sodium salicylate.

[040] In yet another embodiment, the layer overlying the exterior surface of the medical device does not include liposomes or encapsulating particles. In another embodiment, the layer overlying the exterior surface of the medical device includes one of an oil, fatty acid, and lipid.

[041] In one embodiment, the additive in the layer comprising the therapeutic agent, the contrast agent and the additive is an ionic or non-ionic surfactant. In another embodiment, the additive is an aliphatic or aromatic surfactant. In yet another embodiment, the additive is chosen from sorbitan oleate and sorbitan fatty esters.

[042] In another embodiment, the additive is soluble in an aqueous solvent and is soluble in an organic solvent.

[043] In one embodiment, the additive in the layer comprising the therapeutic agent, contrast agent and the additive is chosen from PEG fatty esters, PEG omega-3 fatty esters and alcohols, glycerol fatty esters, sorbitan fatty esters, PEG glyceryl fatty esters, PEG sorbitan fatty esters, sugar fatty esters, PEG sugar esters, vitamins and derivatives.

[044] In one embodiment, the contrast agent in the layer overlying an exterior surface of the medical device is chosen from iobitridol, iohexol, iomeprol, iopamidol, iopentol, iopromide, ioversol, ioxilan, iotrolan, iodixanol, ioxaglate, and their derivatives. In one embodiment, the chemical compound in the layer overlying an exterior surface of the medical device is chosen from amino alcohols, hydroxyl carboxylic acid, ester, anhydrides, hydroxyl ketone, hydroxyl lactone, hydroxyl ester, sugar phosphate, sugar sulfate, ethyl oxide, ethyl glycols, amino acids, peptides, proteins, sorbitan, glycerol, polyalcohol, phosphates, sulfates, organic acids, esters, salts, vitamins, combinations of amino alcohol and organic acid, and

their substituted molecules. In one embodiment, the surfactant in the layer overlying an exterior surface of the medical device is chosen from ionic, nonionic, aliphatic, and aromatic surfactants, PEG fatty esters, PEG omega-3 fatty esters, ether, and alcohols, glycerol fatty esters, sorbitan fatty esters, PEG glyceryl fatty esters, PEG sorbitan fatty esters, sugar fatty esters, PEG sugar esters, and derivatives thereof.

[045] In one embodiment, the chemical compound in the layer overlying an exterior surface of the medical device has one or more hydroxyl, amino, carbonyl, carboxyl, acid, amide or ester groups. In one aspect of this embodiment, the chemical compound having one or more hydroxyl, amino, carbonyl, carboxyl, acid, amide or ester groups is chosen from amino alcohols, hydroxyl carboxylic acid, ester, anhydrides, hydroxyl ketone, hydroxyl lactone, hydroxyl ester, sugar phosphate, sugar sulfate, ethyl oxide, ethyl glycols, amino acids, peptides, proteins, sorbitan, glycerol, polyalcohol, phosphates, sulfates, organic acids, esters, salts, vitamins, combinations of amino alcohol and organic acid, and their substituted molecules.

[046] In another embodiment, the additive in the layer comprising the therapeutic agent, the contrast agent, and the additive is chosen from p-isononylphenoxypolyglycidol, PEG laurate, Tween 20, Tween 40, Tween 60, PEG oleate, PEG stearate, PEG glyceryl laurate, PEG glyceryl oleate, PEG glyceryl stearate, polyglyceryl laurate, polyglyceryl oleate, polyglyceryl myristate, polyglyceryl palmitate, polyglyceryl-6 laurate, polyglyceryl-6 oleate, polyglyceryl-6 myristate, polyglyceryl-6 palmitate, polyglyceryl-10 laurate, polyglyceryl-10 oleate, polyglyceryl-10 myristate, polyglyceryl-10 palmitate PEG sorbitan monolaurate, PEG sorbitan monolaurate, PEG sorbitan monooleate, PEG sorbitan stearate, PEG oleyl ether, PEG lauryl ether, octoxynol, monoxynol, tyloxapol, sucrose monopalmitate, sucrose monolaurate, decanoyl-N-methylglucamide, n-decyl - β -D-glucopyranoside, n-decyl - β -D-maltopyranoside, n-dodecyl - β -D-glucopyranoside, n-dodecyl - β -D-maltoside, heptanoyl-N-methylglucamide, n-heptyl - β -D-glucopyranoside, n-heptyl - β -D-thioglucoside, n-hexyl - β -D-glucopyranoside, nonanoyl-N-methylglucamide, n-nonyl - β -D-glucopyranoside, octanoyl-N-methylglucamide, n-octyl - β -D-glucopyranoside, octyl - β -D-thioglucopyranoside;

cystine, tyrosine, tryptophan, leucine, isoleucine, phenylalanine, asparagine, aspartic acid, glutamic acid, and methionine; acetic anhydride, benzoic anhydride, ascorbic acid, 2-pyrrolidone-5-carboxylic acid, sodium pyrrolidone carboxylate, ethylenediaminetetraacetic dianhydride, maleic and anhydride, succinic anhydride, diglycolic anhydride, glutaric anhydride, acetiamine, benfotiamine, pantothenic acid; cetotiamine; cycothiamine, dexpanthenol, niacinamide, nicotinic acid, pyridoxal 5-phosphate, nicotinamide ascorbate, riboflavin, riboflavin phosphate, thiamine, folic acid, menadiol diphosphate, menadione sodium bisulfite, menadoxime, vitamin B12, vitamin K5, vitamin K6, vitamin K6, and vitamin U; albumin, immunoglobulins, caseins, hemoglobins, lysozymes, immunoglobins, a-2-macroglobulin, fibronectins, vitronectins, fibrinogens, lipases, benzalkonium chloride, benzethonium chloride, docecyl trimethyl ammonium bromide, sodium docecylsulfates, dialkyl methylbenzyl ammonium chloride, and dialkylesters of sodium sulfonsuccinic acid, L-ascorbic acid and its salt, D-glucoascorbic acid and its salt, tromethamine, triethanolamine, diethanolamine, meglumine, glucamine, amine alcohols, glucoheptonic acid, gluconic acid, hydroxyl ketone, hydroxyl lactone, gluconolactone, glucoheptonolactone, glucooctanoic lactone, gulonic acid lactone, mannoic lactone, ribonic acid lactone, lactobionic acid, glucosamine, glutamic acid, benzyl alcohol, benzoic acid, hydroxybenzoic acid, propyl 4-hydroxybenzoate, lysine acetate salt, gentisic acid, lactobionic acid, lactitol, sinapic acid, vanillic acid, vanillin, methyl paraben, propyl paraben, sorbitol, xylitol, cyclodextrin, (2-hydroxypropyl)-cyclodextrin, acetaminophen, ibuprofen, retinoic acid, lysine acetate, gentisic acid, catechin, catechin gallate, tiletamine, ketamine, propofol, lactic acids, acetic acid, salts of any organic acid and organic amine, polyglycidol, glycerol, multiglycerols, galactitol, di(ethylene glycol), tri(ethylene glycol), tetra(ethylene glycol), penta(ethylene glycol), poly(ethylene glycol) oligomers, di(propylene glycol), tri(propylene glycol), tetra(propylene glycol, and penta(propylene glycol), poly(propylene glycol) oligomers, a block copolymer of polyethylene glycol and polypropylene glycol, and derivatives and combinations thereof.

[047] In another embodiment, the additive in the layer comprising the therapeutic agent, the contrast agent, and the additive is chosen from Tyloxapol, Octoxynol, oleth, laureth, PEG-glyceryl, monolaurate, PEG-20 monolaurate, PEG 20 monooleate, PEG 20 glyceryl monooleate, Nonoxynol,

Nonylphenylpoly(glycidol), Octyl-beta-D-glycopyranoside, and deconoyl-N-methylglucamide.

[048] In another embodiment, the additive in the layer comprising the therapeutic agent, the contrast agent, and the additive is chosen from benzalkonium chloride, benzethonium chloride, docecyl trimethyl ammonium bromide, sodium docecylsulfates, dialkyl methylbenzyl ammonium chloride, and dialkylesters of sodium sulfonsuccinic acid.

[049] In one embodiment, the therapeutic agent in the layer comprising the therapeutic agent, the contrast agent, and the additive is one of paclitaxel and analogues thereof, rapamycin and analogues thereof, beta-lapachone and analogues thereof, biological vitamin D and analogues thereof, and a mixture of these therapeutic agents. In another embodiment, the therapeutic agent is in combination with a second therapeutic agent, wherein the therapeutic agent is one of paclitaxel, rapamycin, and analogues thereof, and wherein the second therapeutic agent is one of beta-lapachone, biological active vitamin D, and their analogues. In one embodiment, the therapeutic agent is not water-soluble.

[050] In one embodiment, the additive enhances penetration and absorption of the therapeutic agent in tissue. In one embodiment, the additive enhances release of the therapeutic agent off the medical device, and the therapeutic agent, the contrast agent, and the additive are released. In another embodiment, the additive penetrates tissue, and the therapeutic agent is not water soluble. In another embodiment, the additive has water and alcohol solubility of at least 1 mg/ml and the therapeutic agent is not water soluble.

[051] In one embodiment, the concentration of the contrast agent and the additive in the layer is from 1 to 20 $\mu\text{g}/\text{mm}^2$. The ratio of contrast agent to additive is in the range of 0.2-5.0. In one embodiment, the concentration of the therapeutic agent in the layer is from 1 to 20 $\mu\text{g}/\text{mm}^2$. In another embodiment, the concentration of the therapeutic agent in the layer is from 2 to 6 $\mu\text{g}/\text{mm}^2$.

[052] In one embodiment of the medical device, the device is capable of delivering the therapeutic agent to the tissue in about 0.2 to 10 minutes, or preferably from about 0.1 to 2 minutes. In another embodiment, the device is capable of delivering the therapeutic agent to the tissue in about 0.1 to 1 minute.

[053] In one embodiment, the medical device comprising a layer overlying an exterior surface of the medical device further comprises an adherent layer between the exterior surface of the medical device and the layer. In another embodiment, the device further comprises a top layer overlying the surface of the layer to reduce loss of drug during transit through a body to the tissue. In one embodiment, the top layer comprises an additive that is less hydrophilic than the additive in the layer overlying the exterior surface of the medical device, and wherein the additive of the top layer is chosen from p-isononylphenoxypolyglycidol, PEG laurate, Tween 20, Tween 40, Tween 60, PEG oleate, PEG stearate, PEG glyceryl laurate, PEG glyceryl oleate, PEG glyceryl stearate, polyglyceryl laurate, polyglyceryl oleate, polyglyceryl myristate, polyglyceryl palmitate, polyglyceryl-6 laurate, polyglyceryl-6 oleate, polyglyceryl-6 myristate, polyglyceryl-6 palmitate, polyglyceryl-10 laurate, polyglyceryl-10 oleate, polyglyceryl-10 myristate, polyglyceryl-10 palmitate PEG sorbitan monolaurate, PEG sorbitan monolaurate, PEG sorbitan monooleate, PEG sorbitan stearate, PEG oleyl ether, PEG lauryl ether, octoxynol, monoxynol, tyloxapol, sucrose monopalmitate, sucrose monolaurate, decanoyl-N-methylglucamide, n-decyl - β -D-glucopyranoside, n-decyl - β -D-maltopyranoside, n-dodecyl - β -D-glucopyranoside, n-dodecyl - β -D-maltoside, heptanoyl-N-methylglucamide, n-heptyl- β -D-glucopyranoside, n-heptyl - β -D-thioglucoside, n-hexyl - β -D-glucopyranoside, nonanoyl-N-methylglucamide, n-nonyl - β -D-glucopyranoside, octanoyl-N-methylglucamide, n-octyl- β -D-glucopyranoside, octyl - β -D-thioglucopyranoside; cystine, tyrosine, tryptophan, leucine, isoleucine, phenylalanine, asparagine, aspartic acid, glutamic acid, and methionine; acetic anhydride, benzoic anhydride, ascorbic acid, 2-pyrrolidone-5-carboxylic acid, sodium pyrrolidone carboxylate, ethylenediaminetetraacetic dianhydride, maleic and anhydride, succinic anhydride, diglycolic anhydride, glutaric anhydride, acetiamine, benfotiamine, pantothenic acid; cetotiamine; cycothiamine, dexpanthenol, niacinamide, nicotinic acid, pyridoxal 5-phosphate, nicotinamide ascorbate, riboflavin, riboflavin phosphate, thiamine, folic acid, menadiol diphosphate, menadione sodium bisulfite, menadoxime, vitamin B12, vitamin K5, vitamin K6, vitamin K6, and vitamin U; albumin, immunoglobulins, caseins, hemoglobins, lysozymes, immunoglobins, a-2-macroglobulin, fibronectins,

vitronectins, fibrinogens, lipases, benzalkonium chloride, benzethonium chloride, docecyl trimethyl ammonium bromide, sodium docecylsulfates, dialkyl methylbenzyl ammonium chloride, and dialkylesters of sodium sulfonsuccinic acid, L-ascorbic acid and its salt, D-glucoascorbic acid and its salt, tromethamine, triethanolamine, diethanolamine, meglumine, glucamine, amine alcohols, glucoheptonic acid, glucomic acid, hydroxyl ketone, hydroxyl lactone, gluconolactone, glucoheptonolactone, glucooctanoic lactone, gulonic acid lactone, mannoic lactone, ribonic acid lactone, lactobionic acid, glucosamine, glutamic acid, benzyl alcohol, benzoic acid, hydroxybenzoic acid, propyl 4-hydroxybenzoate, lysine acetate salt, gentisic acid, lactobionic acid, lactitol, sinapic acid, vanillic acid, vanillin, methyl paraben, propyl paraben, sorbitol, xylitol, cyclodextrin, (2-hydroxypropyl)-cyclodextrin, acetaminophen, ibuprofen, retinoic acid, lysine acetate, gentisic acid, catechin, catechin gallate, tiletamine, ketamine, propofol, lactic acids, acetic acid, salts of any organic acid and organic amine, polyglycidol, glycerol, multiglycerols, galactitol, di(ethylene glycol), tri(ethylene glycol), tetra(ethylene glycol), penta(ethylene glycol), poly(ethylene glycol) oligomers, di(propylene glycol), tri(propylene glycol), tetra(propylene glycol, and penta(propylene glycol), poly(propylene glycol) oligomers, a block copolymer of polyethylene glycol and polypropylene glycol, and derivatives and combinations thereof. In another embodiment, the medical device further comprises a dimethylsulfoxide solvent layer, wherein the dimethylsulfoxide solvent layer is overlying the surface of the layer.

[054] In another embodiment of the medical device, the layer overlying the exterior surface of the medical device comprises a therapeutic agent, a contrast agent, and at least two additives, wherein each of the additives comprises a hydrophilic part and a drug affinity part, wherein the drug affinity part is a hydrophobic part and/or has an affinity to the therapeutic agent by hydrogen bonding and/or van der Waals interactions.

[055] In another embodiment of the medical device, the layer overlying the exterior surface of the medical device comprises a therapeutic agent, a contrast agent, and an additive, wherein the additive comprises a hydrophilic part and a drug affinity part, wherein the drug affinity part is a hydrophobic part and/or has an affinity to the therapeutic agent by hydrogen bonding and/or van der Waals

interactions, wherein the additive reduces crystal size and number of particles of the therapeutic agent, and wherein the therapeutic agent is not water soluble and is not enclosed in micelles or liposomes or encapsulated in polymer particles.

[056] In another embodiment of the medical device, the layer overlying the exterior surface of the medical device comprises a therapeutic agent, a contrast agent and an additive, wherein the additive comprises a hydrophilic part and a drug affinity part, wherein the additive has a fatty chain of an acid, ester, ether, or alcohol, wherein the fatty chain directly inserts into lipid membrane structures of tissue, wherein the additive has one or more functional groups which have affinity to the drug by hydrogen bonding and/or van der Waals interactions (the functional groups include hydroxyl, ester, amide, carboxylic acid, primary, second, and tertiary amine, carbonyl, anhydrides, oxides, and amino alcohols), wherein the therapeutic agent is not water soluble and is not encapsulated in polymer particles, and wherein the layer does not include polymer.

[057] In another embodiment of the medical device, the layer overlying the exterior surface of the medical device comprises a therapeutic agent, a contrast agent, and an additive, wherein the additive comprises a hydrophilic part and a drug affinity part, wherein the drug affinity part is a hydrophobic part and/or has an affinity to the therapeutic agent by hydrogen bonding and/or van der Waals interactions, wherein the additive is a surfactant and has a fatty chain of an acid, ester, ether, or alcohol, wherein the fatty chain directly inserts into the lipid membrane structures of the tissue, and wherein the therapeutic agent is not water soluble and is not encapsulated in polymer particles.

[058] In another embodiment, the present invention relates to a balloon catheter for delivering a therapeutic agent to a blood vessel for reducing stenosis and late lumen loss of body lumen, the catheter comprising a coating layer overlying an exterior surface of a balloon. In one embodiment of the balloon catheter, the coating layer comprises a therapeutic agent, a contrast agent, and an additive, wherein the additive comprises a hydrophilic part and a drug affinity part, wherein the drug affinity part is at least one of a hydrophobic part, a part that has an affinity to the therapeutic agent by hydrogen bonding, and a part that has an affinity to the therapeutic agent by van der Waals interactions, wherein the additive is water-soluble, and wherein the additive is at least one of a surfactant and a

chemical compound. In one embodiment, the therapeutic agent is not encapsulated in polymer particles. In one embodiment, the coating layer overlying an exterior surface of the exterior surface of the balloon catheter consists essentially of the therapeutic agent, the contrast agent, and the additive.

[059] In one embodiment of the balloon catheter, the contrast agent in the coating layer overlying an exterior surface of a balloon is chosen from iobitridol, iohexol, iomeprol, iopamidol, iopentol, iopromide, ioversol, ioxilan, iotrolan, iodixanol, ioxaglate, and their derivatives. In one embodiment of the balloon catheter, the surfactant is chosen from ionic, nonionic, aliphatic, and aromatic surfactants, PEG fatty esters, PEG omega-3 fatty esters, ether, and alcohols, glycerol fatty esters, sorbitan fatty esters, PEG glyceryl fatty esters, PEG sorbitan fatty esters, sugar fatty esters, PEG sugar esters, and derivatives thereof. In one embodiment, the chemical compound has one or more hydroxyl, amino, carbonyl, carboxyl, acid, amide or ester groups. In one aspect of this embodiment, the chemical compound having one or more hydroxyl, amino, carbonyl, carboxyl, acid, amide or ester groups is chosen from amino alcohols, hydroxyl carboxylic acid, ester, and anhydrides, hydroxyl ketone, hydroxyl lactone, hydroxyl ester, sugar phosphate, sugar sulfate, ethyl oxide, ethyl glycols, amino acids, peptides, proteins, sorbitan, glycerol, polyalcohol, phosphates, sulfates, organic acids, esters, salts, vitamins, combinations of amino alcohol and organic acid, and their substituted molecules.

[060] In one embodiment of the balloon catheter, the additive in the coating layer is an ionic or non-ionic surfactant. In another embodiment, the additive is a vitamin or derivative thereof. In another embodiment, the additive is soluble in an aqueous solvent and is soluble in an organic solvent. In yet another embodiment, the additive is chosen from sorbitan oleate and sorbitan fatty esters.

[061] In one embodiment, the additive in the coating layer comprising the therapeutic agent, the contrast agent, and the additive is chosen from PEG fatty esters, PEG omega-3 fatty esters and alcohols, glycerol fatty esters, sorbitan fatty esters, PEG glyceryl fatty esters, PEG sorbitan fatty esters, sugar fatty esters, PEG sugar esters, vitamins and derivatives.

[062] In another embodiment, the additive in the coating layer comprising the therapeutic agent, the contrast agent, and the additive is chosen from p-

isononylphenoxypolyglycidol, PEG laurate, PEG oleate, PEG stearate, PEG glyceryl laurate, PEG glyceryl oleate, PEG glyceryl stearate, polyglyceryl laurate, polyglyceryl oleate, polyglyceryl myristate, polyglyceryl palmitate, polyglyceryl-6 laurate, polyglyceryl-6 oleate, polyglyceryl-6 myristate, polyglyceryl-6 palmitate, polyglyceryl-10 laurate, polyglyceryl-10 oleate, polyglyceryl-10 myristate, polyglyceryl-10 palmitate PEG sorbitan monolaurate, PEG sorbitan monooleate, PEG sorbitan stearate, PEG oleyl ether, PEG lauryl ether, octoxynol, monoxynol, tyloxapol, Tween 20, Tween 40, Tween 60, Tween 80, sucrose monopalmitate, sucrose monolaurate, decanoyl-N-methylglucamide, n-decyl - β -D-glucopyranoside, n-decyl - β -D-maltopyranoside, n-dodecyl - β -D-glucopyranoside, n-dodecyl - β -D-maltoside, heptanoyl-N-methylglucamide, n-heptyl - β -D-glucopyranoside, n-heptyl - β -D-thioglucoside, n-hexyl - β -D-glucopyranoside, nonanoyl-N-methylglucamide, n-nonyl - β -D-glucopyranoside, octanoyl-N-methylglucamide, n-octyl - β -D-glucopyranoside,

[063] In another embodiment, the additive in the coating layer comprising the therapeutic agent, the contrast agent, and the additive is chosen from Tyloxapol, Octoxynol, oleth, laureth, PEG-glyceryl, monolaurate, PEG-20 monolaurate, PEG 20 monooleate, PEG 20 glyceryl monooleate, Nonoxynol, Nonylphenylpoly(glycidol), Octyl-beta-D-glycopyranoside, and deconoyl-N-methylglucamide.

[064] In another embodiment, the additive in the coating layer comprising the therapeutic agent, the contrast agent, and the additive is chosen from benzalkonium chloride, benzethonium chloride, docecyl trimethyl ammonium bromide, sodium docecylsulfates, dialkyl methylbenzyl ammonium chloride, and dialkylesters of sodium sulfonsuccinic acid.

[065] In one embodiment, the therapeutic agent is one of paclitaxel and analogues thereof, rapamycin and analogues thereof, beta-lapachone and analogues thereof, biological vitamin D and analogues thereof, and a mixture of these therapeutic agents. In another embodiment, the therapeutic agent is in combination with a second therapeutic agent, wherein the therapeutic agent is one of paclitaxel, rapamycin, and analogues thereof, and wherein the second

therapeutic agent is one of beta-lapachone, biological active vitamin D and their analogues. In one embodiment, the therapeutic agent is not water soluble.

[066] In one embodiment, the additive enhances penetration and absorption of the therapeutic agent in the blood vessel. In another embodiment, the additive penetrates the blood vessel, and the therapeutic agent is not water-soluble. In another embodiment, the additive has water and ethanol solubility of at least 1 mg/ml, and the therapeutic agent is not water soluble.

[067] In one embodiment of the balloon catheter, the catheter further comprises an adherent layer between the exterior surface of the balloon and the coating layer. In another embodiment, the catheter further comprises a top layer overlying the coating layer, wherein the top layer reduces loss of the therapeutic agent during transit through a body to the blood vessel. The top layer comprises an additive selected from those additives according to embodiments of the invention described herein. The top layer will be slowly dissolved during transit through a body to the body lumen to the target site for therapeutic intervention. This top layer will reduce drug loss during transit and increase the drug available to the tissue when the medical device of embodiments of the present invention is pressed into contact with luminal tissue. In one embodiment, the additive in the top layer is less hydrophilic than the additive in the coating layer. In another embodiment, the catheter further comprises a dimethylsulfoxide solvent layer, wherein the dimethylsulfoxide solvent layer is overlying the surface of the coating layer.

[068] In one embodiment, the balloon catheter is capable of delivering the therapeutic agent to the blood vessel in about 0.1 to 2 minutes. In another embodiment, the balloon catheter is capable of delivering the therapeutic agent to the blood vessel in about 0.1 to 1 minute.

[069] In one embodiment of the balloon catheter, the concentration of the therapeutic agent in the coating layer is from 1 to 20 $\mu\text{g}/\text{mm}^2$. In another embodiment, the concentration of the therapeutic agent in the coating layer is from 2 to 6 $\mu\text{g}/\text{mm}^2$. In one embodiment, the concentration of the additive in the coating layer is from 1 to 10 $\mu\text{g}/\text{mm}^2$. In one embodiment, the concentration of the contrast agent in the coating layer is from 1 to 10 $\mu\text{g}/\text{mm}^2$.

[070] In one embodiment, the present invention relates to a balloon catheter for delivering a therapeutic agent to a blood vessel, the catheter comprising a

coating layer overlying the exterior surface of a balloon, the coating layer comprising a therapeutic agent, a contrast agent, and an additive, wherein the additive comprises a hydrophilic part and a drug affinity part, wherein the drug affinity part is at least one of a hydrophobic part, a part that has an affinity to the therapeutic agent by hydrogen bonding, and a part that has an affinity to the therapeutic agent by van der Waals interactions, wherein the additive is chosen from p-isononylphenoxypolyglycidol, PEG laurate, Tween 20, Tween 40, Tween 60, PEG oleate, PEG stearate, PEG glyceryl laurate, PEG glyceryl oleate, PEG glyceryl stearate, polyglyceryl laurate, polyglyceryl oleate, polyglyceryl myristate, polyglyceryl palmitate, polyglyceryl-6 laurate, polyglyceryl-6 oleate, polyglyceryl-6 myristate, polyglyceryl-6 palmitate, polyglyceryl-10 laurate, polyglyceryl-10 oleate, polyglyceryl-10 myristate, polyglyceryl-10 palmitate, PEG sorbitan monolaurate, PEG sorbitan monolaurate, PEG sorbitan monooleate, PEG sorbitan stearate, PEG oleyl ether, PEG lauryl ether, octoxynol, monoxynol, tyloxapol, sucrose monopalmitate, sucrose monolaurate, decanoyl-N-methylglucamide, n-decyl - β -D-glucopyranoside, n-decyl - β -D-maltopyranoside, n-dodecyl - β -D-glucopyranoside, n-dodecyl - β -D-maltoside, heptanoyl-N-methylglucamide, n-heptyl - β -D-glucopyranoside, n-heptyl - β -D-thioglucoside, n-hexyl - β -D-glucopyranoside, nonanoyl-N-methylglucamide, n-nonyl - β -D-glucopyranoside, octanoyl-N-methylglucamide, n-octyl - β -D-glucopyranoside, octyl - β -D-thioglucopyranoside; cystine, tyrosine, tryptophan, leucine, isoleucine, phenylalanine, asparagine, aspartic acid, glutamic acid, and methionine; acetic anhydride, benzoic anhydride, ascorbic acid, 2-pyrrolidone-5-carboxylic acid, sodium pyrrolidone carboxylate, ethylenediaminetetraacetic dianhydride, maleic anhydride, succinic anhydride, diglycolic anhydride, glutaric anhydride, acetiamine, benfotiamine, pantothenic acid; cetotiamine; cycothiamine, dexpanthenol, niacinamide, nicotinic acid, pyridoxal 5-phosphate, nicotinamide ascorbate, riboflavin, riboflavin phosphate, thiamine, folic acid, menadiol diphosphate, menadione sodium bisulfite, menadoxime, vitamin B12, vitamin K5, vitamin K6, vitamin K6, and vitamin U; albumin, immunoglobulins, caseins, hemoglobins, lysozymes, immunoglobins, α -2-macroglobulin, fibronectins, vitronectins, fibrinogens, lipases, benzalkonium chloride, benzethonium chloride, docecyl trimethyl ammonium bromide, sodium docecylsulfates, dialkyl methylbenzyl

ammonium chloride, and dialkylesters of sodium sulfonsuccinic acid, L-ascorbic acid and its salt, D-glucoascorbic acid and its salt, tromethamine, triethanolamine, diethanolamine, meglumine, glucamine, amine alcohols, glucoheptonic acid, gluconic acid, hydroxyl ketone, hydroxyl lactone, gluconolactone, glucoheptonolactone, glucooctanoic lactone, gulonic acid lactone, mannoic lactone, ribonic acid lactone, lactobionic acid, glucosamine, glutamic acid, benzyl alcohol, benzoic acid, hydroxybenzoic acid, propyl 4-hydroxybenzoate, lysine acetate salt, gentisic acid, lactobionic acid, lactitol, sinapic acid, vanillic acid, vanillin, methyl paraben, propyl paraben, sorbitol, xylitol, cyclodextrin, (2-hydroxypropyl)-cyclodextrin, acetaminophen, ibuprofen, retinoic acid, lysine acetate, gentisic acid, catechin, catechin gallate, tiletamine, ketamine, propofol, lactic acids, acetic acid, salts of any organic acid and organic amine, polyglycidol, glycerol, multiglycerols, galactitol, di(ethylene glycol), tri(ethylene glycol), tetra(ethylene glycol), penta(ethylene glycol), poly(ethylene glycol) oligomers, di(propylene glycol), tri(propylene glycol), tetra(propylene glycol, and penta(propylene glycol), poly(propylene glycol) oligomers, a block copolymer of polyethylene glycol and polypropylene glycol, and derivatives and combinations thereof.

[071] In yet a further embodiment, the present invention relates to a balloon catheter for delivering a therapeutic agent to a blood vessel. In one aspect of this embodiment, the catheter comprises an elongate member having a lumen and a distal end, an expandable balloon attached to the distal end of the elongate member and in fluid communication with the lumen, and a coating layer overlying an exterior surface of the balloon. In one aspect of this embodiment, the coating layer overlying the surface of the balloon comprises a lipophilic or water-insoluble therapeutic agent, a contrast agent, and an additive, wherein the additive comprises a hydrophilic part and a drug affinity part, wherein the drug affinity part comprises a hydrophobic part and/or has an affinity to the therapeutic agent by hydrogen bonding and/or van der Waals interactions, wherein the additive is water-soluble, and wherein the catheter is capable of delivering the therapeutic agent to the blood vessel in less than about 2 minutes. In one aspect of this embodiment, the layer does not include a purely hydrophobic additive.

[072] In one embodiment, the coating layer overlying the surface of the balloon consists essentially of the therapeutic agent, the contrast agent, and the

additive. In one embodiment, the therapeutic agent in the coating layer overlying the surface of the balloon is paclitaxel and analogues thereof. In another embodiment, the therapeutic agent in the coating layer overlying the surface of the balloon is rapamycin and analogues thereof. In one embodiment, the coating layer overlying the surface of the contains two therapeutic agents, one of which is paclitaxel or analogues thereof or rapamycin or analogues thereof, and the second of which is selected from agents that inhibit vasospasm.

[073] In one embodiment, the concentration of the therapeutic agent in the coating layer is from 2.5 to 6 $\mu\text{g}/\text{mm}^2$.

[074] In one embodiment, the additive in the coating layer overlying the surface of the balloon is an ionic or non-ionic surfactant. In another embodiment, the additive in the coating layer overlying the surface of the balloon is a vitamin or derivative thereof.

[075] In one embodiment, the additive in the coating layer overlying the surface of the balloon is chosen from Tyloxapol, Octoxynol, oleth, laureth, PEG-glyceryl, monolaurate, PEG-20 monolaurate, PEG 20 monooleate, PEG 20 glyceryl monooleate, Nonoxynol, Nonylphenylpoly(glycidol), Octyl-betha-D-glycopyranoside, and deconoyl-N-methylglucamide. In another embodiment, the additive in the coating layer overlying the surface of the balloon is chosen from PEG fatty esters, PEG omega-3 fatty esters and alcohols, glycerol fatty esters, sorbitan fatty esters, PEG glyceryl fatty esters, PEG sorbitan fatty esters, sugar fatty esters, PEG sugar esters, vitamins and derivatives.

[076] In another embodiment, the additive in the coating layer overlying the surface of the balloon is chosen from p-isononylphenoxyglycidol, PEG laurate, PEG oleate, PEG stearate, PEG glyceryl laurate, PEG glyceryl oleate, PEG glyceryl stearate, polyglyceryl laurate, polyglyceryl oleate, polyglyceryl myristate, polyglyceryl palmitate, polyglyceryl-6 laurate, polyglyceryl-6 oleate, polyglyceryl-6 myristate, polyglyceryl-6 palmitate, polyglyceryl-10 laurate, polyglyceryl-10 oleate, polyglyceryl-10 myristate, polyglyceryl-10 palmitate PEG sorbitan monolaurate, PEG sorbitan monolaurate, PEG sorbitan monooleate, PEG sorbitan stearate, PEG oleyl ether, PEG lauryl ether, octoxynol, monoxynol, tyloxapol, sucrose monopalmitate, sucrose monolaurate, Tween 20, Tween 40, Tween 60, Tween 80,

decanoyl-N-methylglucamide, n-decyl - β -D-glucopyranoside, n-decyl - β -D-maltopyranoside, n-dodecyl - β -D-glucopyranoside, n-dodecyl - β -D-maltoside, heptanoyl-N-methylglucamide, n-heptyl- β -D-glucopyranoside, n-heptyl - β -D-thioglucoside, n-hexyl - β -D-glucopyranoside, nonanoyl-N-methylglucamide, n-nonyl - β -D-glucopyranoside, octanoyl-N-methylglucamide, n-octyl- β -D-glucopyranoside, and octyl - β -D-thioglucopyranoside. In yet another embodiment, the additive in the coating layer overlying the surface of the balloon is chosen from benzalkonium chloride, benzethonium chloride, docecyl trimethyl ammonium bromide, sodium docecylsulfates, dialkyl methylbenzyl ammonium chloride, and dialkylesters of sodium sulfonsuccinic acid.

[077] In one embodiment, the balloon catheter further comprises a dimethylsulfoxide solvent layer overlying the coating layer, wherein the dimethylsulfoxide layer enhances the ability of the therapeutic agent to penetrate into the blood vessel. In another embodiment, the balloon catheter further comprises an adherent layer between the exterior surface of the balloon and the coating layer. In yet another embodiment, the balloon catheter further comprises a top layer overlying the coating layer, wherein the top layer reduces loss of the therapeutic agent and/or contrast agent, and/or additive in the coating layer during transit through a body or blood vessel to the target site for intervention.

[078] In yet a further embodiment, the present invention relates to a pharmaceutical composition comprising a therapeutic agent, a contrast agent, and an additive, wherein the additive comprises a hydrophilic part and a drug affinity part, wherein the drug affinity part is at least one of a hydrophobic part, a part that has an affinity to the therapeutic agent by hydrogen bonding, and a part that has an affinity to the therapeutic agent by van der Waals interactions, wherein the additive is water-soluble, wherein the additive is at least one of a surfactant and a chemical compound.

[079] In one embodiment, the contrast agent is chosen from iobitridol, iohexol, iomeprol, iopamidol, iopentol, iopromide, ioversol, ioxilan, iotrolan, iodixanol, ioxaglate, and their derivatives. In one embodiment, the surfactant is chosen from ionic, nonionic, aliphatic, and aromatic surfactants, PEG fatty esters, PEG omega-3 fatty esters, ether, and alcohols, glycerol fatty esters, sorbitan fatty

esters, PEG glyceryl fatty esters, PEG sorbitan fatty esters, sugar fatty esters, PEG sugar esters and derivatives thereof. In one embodiment, the chemical compound has one or more hydroxyl, amino, carbonyl, carboxyl, acid, amide or ester groups. In one aspect of this embodiment, the chemical compound having one or more hydroxyl, amino, carbonyl, carboxyl, acid, amide or ester groups is chosen from amino alcohols, hydroxyl carboxylic acid, ester, and anhydrides, hydroxyl ketone, hydroxyl lactone, hydroxyl ester, sugar phosphate, sugar sulfate, ethyl oxide, ethyl glycols, amino acids, peptides, proteins, sorbitan, glycerol, polyalcohol, phosphates, sulfates, organic acids, esters, salts, vitamins, combinations of amino alcohol and organic acid, and their substituted molecules.

[080] In one embodiment of the pharmaceutical composition, the additive is chosen from p-isononylphenoxypolyglycidol, PEG laurate, Tween 20, Tween 40, Tween 60, PEG oleate, PEG stearate, PEG glyceryl laurate, PEG glyceryl oleate, PEG glyceryl stearate, polyglyceryl laurate, polyglyceryl oleate, polyglyceryl myristate, polyglyceryl palmitate, polyglyceryl-6 laurate, polyglyceryl-6 oleate, polyglyceryl-6 myristate, polyglyceryl-6 palmitate, polyglyceryl-10 laurate, polyglyceryl-10 oleate, polyglyceryl-10 myristate, polyglyceryl-10 palmitate PEG sorbitan monolaurate, PEG sorbitan monolaurate, PEG sorbitan monooleate, PEG sorbitan stearate, PEG oleyl ether, PEG lauryl ether, octoxynol, monoxynol, tyloxapol, sucrose monopalmitate, sucrose monolaurate, decanoyl-N-methylglucamide, n-decyl - β -D-glucopyranoside, n-decyl - β -D-maltopyranoside, n-dodecyl - β -D-glucopyranoside, n-dodecyl - β -D-maltoside, heptanoyl-N-methylglucamide, n-heptyl - β -D-glucopyranoside, n-heptyl - β -D-thioglucoside, n-hexyl - β -D-glucopyranoside, nonanoyl-N-methylglucamide, n-nonyl - β -D-glucopyranoside, octanoyl-N-methylglucamide, n-octyl - β -D-glucopyranoside, octyl - β -D-thioglucopyranoside; cystine, tyrosine, tryptophan, leucine, isoleucine, phenylalanine, asparagine, aspartic acid, glutamic acid, and methionine; acetic anhydride, benzoic anhydride, ascorbic acid, 2-pyrrolidone-5-carboxylic acid, sodium pyrrolidone carboxylate, ethylenediaminetetraacetic dianhydride, maleic and anhydride, succinic anhydride, diglycolic anhydride, glutaric anhydride, acetiamine, benfotiamine, pantothenic acid; cetotiamine; cycothiamine, dexpanthenol, niacinamide, nicotinic acid, pyridoxal 5-phosphate, nicotinamide

ascorbate, riboflavin, riboflavin phosphate, thiamine, folic acid, menadiol diphosphate, menadione sodium bisulfite, menadoxime, vitamin B12, vitamin K5, vitamin K6, vitamin K6, and vitamin U; albumin, immunoglobulins, caseins, hemoglobins, lysozymes, immunoglobins, a-2-macroglobulin, fibronectins, vitronectins, firbinogens, lipases, benzalkonium chloride, benzethonium chloride, docecyl trimethyl ammonium bromide, sodium docecylsulfates, dialkyl methylbenzyl ammonium chloride, and dialkylesters of sodium sulfonsuccinic acid, L-ascorbic acid and its salt, D-glucoascorbic acid and its salt, tromethamine, triethanolamine, diethanolamine, meglumine, glucamine, amine alcohols, glucoheptonic acid, glucomic acid, hydroxyl ketone, hydroxyl lactone, gluconolactone, glucoheptonolactone, glucooctanoic lactone, gulonic acid lactone, mannoic lactone, ribonic acid lactone, lactobionic acid, glucosamine, glutamic acid, benzyl alcohol, benzoic acid, hydroxybenzoic acid, propyl 4-hydroxybenzoate, lysine acetate salt, gentisic acid, lactobionic acid, lactitol, sinapic acid, vanillic acid, vanillin, methyl paraben, propyl paraben, sorbitol, xylitol, cyclodextrin, (2-hydroxypropyl)-cyclodextrin, acetaminophen, ibuprofen, retinoic acid, lysine acetate, gentisic acid, catechin, catechin gallate, tiletamine, ketamine, propofol, lactic acids, acetic acid, salts of any organic acid and organic amine, polyglycidol, glycerol, multiglycerols, galactitol, di(ethylene glycol), tri(ethylene glycol), tetra(ethylene glycol), penta(ethylene glycol), poly(ethylene glycol) oligomers, di(propylene glycol), tri(propylene glycol), tetra(propylene glycol, and penta(propylene glycol), poly(propylene glycol) oligomers, a block copolymer of polyethylene glycol and polypropylene glycol, and derivatives and combinations thereof.

[081] In yet a further embodiment, the present invention relates to a pharmaceutical composition for treating a diseased body lumen or cavity after a surgical or interventional procedure, wherein the composition comprises a therapeutic agent, a contrast agent, and an additive, wherein the additive comprises a hydrophilic part and a drug affinity part, wherein the therapeutic agent is not enclosed in micelles or liposomes or encapsulated in polymer particles.

[082] In yet a further embodiment, the present invention relates to a method for treating a diseased body lumen or cavity after a surgical or interventional procedure comprising delivering a pharmaceutical composition at a surgical site by injection or spraying with a catheter, wherein the composition comprises a

therapeutic agent, a contrast agent, and an additive, wherein the additive comprises a hydrophilic part and a drug affinity part, wherein the therapeutic agent is not enclosed in micelles or liposomes or encapsulated in polymer particles.

[083] In yet a further embodiment, the present invention relates to a pharmaceutical composition for treating a cancer including cancers of the ovary, breast, lung, esophagus, head and neck region, bladder, brain, liver, colon and lymphomas, wherein the composition comprises a therapeutic agent, a contrast agent, and an additive, wherein the additive comprises a hydrophilic part and a drug affinity part, wherein the drug affinity part is a hydrophobic part and/or has an affinity to the therapeutic agent by hydrogen bonding and/or van der Waals interactions, and wherein the therapeutic agent is not enclosed in micelles or liposomes or encapsulated in polymer particles. In one aspect of this embodiment, the therapeutic agent is chosen from paclitaxel and analogues thereof and rapamycin and analogues thereof.

[084] In yet a further embodiment, the present invention relates to a solution for coating a medical device. In one aspect of this embodiment, the solution comprises an organic solvent, a therapeutic agent, a contrast agent, and an additive, wherein the additive comprises a hydrophilic part and a drug affinity part, wherein the drug affinity part is a hydrophobic part and/or has an affinity to the therapeutic agent by hydrogen bonding and/or van der Waals interactions, and wherein the therapeutic agent is not enclosed in micelles liposomes or encapsulated in polymer particles. In one aspect of this embodiment, the solution does not include a purely hydrophobic additive. In another embodiment, the solution for coating a medical device does not include oil, a lipid, or a polymer.

[085] In one embodiment, the additive in the coating solution is an ionic or non-ionic surfactant. In another embodiment, the additive is a vitamin or derivative thereof.

[086] In one embodiment, the additive in the coating solution is chosen from Tyloxapol, Octoxynol, oleth, laureth, PEG-glyceryl, monolaurate, PEG-20 monolaurate, PEG 20 monooleate, PEG 20 glyceryl monooleate, Nonoxynol, Nonylphenylpoly(glycidol), Octyl-beta-D-glycopyranoside, and deconoyl-N-methylglucamide.

[087] In another embodiment, the additive in the coating solution is chosen from PEG fatty esters, PEG omega-3 fatty esters and alcohols, glycerol fatty esters, sorbitan fatty esters, PEG glyceryl fatty esters, PEG sorbitan fatty esters, sugar fatty esters, PEG sugar esters, vitamins and derivatives, amino acids, multi amino acids and derivatives, peptides, polypeptides, proteins, quaternary ammonium salts, organic acids, salts and anhydrides.

[088] In another embodiment, the additive in the coating solution is chosen from p-isononylphenoxypolyglycidol, PEG laurate, PEG oleate, PEG stearate, PEG glyceryl laurate, PEG glyceryl oleate, PEG glyceryl stearate, polyglyceryl laurate, polyglyceryl oleate, polyglyceryl myristate, polyglyceryl palmitate, polyglyceryl-6 laurate, polyglyceryl-6 oleate, polyglyceryl-6 myristate, polyglyceryl-6 palmitate, polyglyceryl-10 laurate, polyglyceryl-10 oleate, polyglyceryl-10 myristate, polyglyceryl-10 palmitate, PEG sorbitan monolaurate, PEG sorbitan monolaurate, PEG sorbitan monooleate, PEG sorbitan stearate, PEG oleyl ether, PEG lauryl ether, octoxynol, monoxynol, tyloxapol, Tween 20, Tween 40, Tween 60, Tween 80, sucrose monopalmitate, sucrose monolaurate, decanoyl-N-methylglucamide, n-decyl - β -D-glucopyranoside, n-decyl - β -D-maltopyranoside, n-dodecyl - β -D-glucopyranoside, n-dodecyl - β -D-maltoside, heptanoyl-N-methylglucamide, n-heptyl - β -D-glucopyranoside, n-heptyl - β -D-thioglucoside, n-hexyl - β -D-glucopyranoside, nonanoyl-N-methylglucamide, n-nonyl - β -D-glucopyranoside, octanoyl-N-methylglucamide, n-octyl - β -D-glucopyranoside, octyl - β -D-thioglucopyranoside, benzalkonium chloride, benzethonium chloride, docecyl trimethyl ammonium bromide, sodium docecylsulfates, dialkyl methylbenzyl ammonium chloride, and dialkylesters of sodium sulfonsuccinic acid (ionic surfactants).

[089] In another embodiment, the additive in the solution is chosen from sorbitan fatty esters. In yet another embodiment, the additive in the coating solution is chosen from benzalkonium chloride, benzethonium chloride, docecyl trimethyl ammonium bromide, sodium docecylsulfates, dialkyl methylbenzyl ammonium chloride, and dialkylesters of sodium sulfonsuccinic acid.

[090] In one embodiment, the therapeutic agent in the coating solution is paclitaxel or analogues thereof or rapamycin or analogues thereof.

[091] In one embodiment, the content of the therapeutic agent in the solution is from 0.5-50% by weight. In one embodiment, the content of the additive in the coating solution is from 1-45% by weight. In one embodiment, the content of the contrast agent in the coating solution is from 1-45% by weight.

[092] In one embodiment, the additive in the solution is soluble in aqueous solvent and is soluble in organic solvent.

[093] In yet a further embodiment, the present invention relates to a medical device for delivering a therapeutic agent to a tissue, the device comprising a first layer applied to an exterior surface of the medical device, and a second layer overlying the first layer. In one aspect of this embodiment, the first layer comprises a therapeutic agent, and the second layer comprises a contrast agent and an additive, wherein the additive comprises a hydrophilic part and a drug affinity part, and wherein the therapeutic agent in the first layer is not enclosed in micelles or liposomes or encapsulated in polymer particles. In one aspect of this embodiment, the first layer further comprises a contrast agent and an additive. In another aspect of this embodiment, the second layer further comprises a therapeutic agent. In yet a further aspect of this embodiment, the first layer further comprises an additive and the second layer further comprises a therapeutic agent.

[094] In a further embodiment, the present invention relates to a two layer coating comprising a first layer comprising a therapeutic agent, and a second layer comprising a contrast agent and an additive. In one aspect of this embodiment, the second layer may be overlying the first layer. In one aspect of this embodiment, the additive in the second layer comprises a hydrophilic part and a drug affinity part, and the therapeutic agent in the first layer is not enclosed in micelles or liposomes or encapsulated in polymer particles. In one aspect of this embodiment, the first layer further comprises an additive. In another aspect of this embodiment, the second layer further comprises a therapeutic agent. In yet another aspect of this embodiment, the first layer further comprises an additive or a contrast agent and the second layer further comprises a therapeutic agent.

[095] In a further embodiment, the present invention relates to a method for preparing a medical device. In one aspect of this embodiment, the method comprises (a) preparing a coating solution comprising an organic solvent, a therapeutic agent, a contrast agent, and an additive, wherein the additive

comprises a hydrophilic part and a drug affinity part, wherein the drug affinity part is a hydrophobic part and/or has an affinity to the therapeutic agent by hydrogen bonding and/or van der Waals interactions, and wherein the therapeutic agent is not enclosed in micelles or encapsulated in polymer particles, (b) applying the coating solution to a medical device, and (c) drying the coating solution, forming a coating layer. In one aspect of this embodiment, the coating is applied by dipping a portion of the exterior surface of the medical device in the coating solution. In another aspect of this embodiment, the coating is applied by spraying a portion of the exterior surface of the medical device with a coating solution. In another aspect of this embodiment, steps (b) and (c) are repeated until a therapeutically effective amount of the therapeutic agent in the coating layer is deposited on the surface of the medical device. In another aspect of this embodiment, the total thickness of the coating layer is from about 0.1 to 200 microns. In another aspect of this embodiment, the concentration density of the at least one therapeutic agent applied to the surface of the medical device is from about 1 to 20 $\mu\text{g}/\text{mm}^2$, or in another aspect from about 2 to 6 $\mu\text{g}/\text{mm}^2$. In yet another aspect of this embodiment, the method further comprises applying a dimethylsulfoxide solvent to the dried coating layer obtained in step (c).

[096] In another embodiment, the method for preparing the medical device comprises, (a) preparing a coating solution comprising an organic solvent, a therapeutic agent, a contrast agent, and an additive, wherein the additive is an anhydride, (b) applying the coating solution to a medical device, (c) drying the coating solution, forming a coating layer, and (d) hydrolyzing the anhydride to an acid group.

[097] In a further embodiment, the present invention relates to a method for preparing a drug coated balloon catheter. In one aspect of this embodiment, the method comprises, (a) preparing a coating solution comprising an organic solvent, a therapeutic agent, a contrast agent, and an additive, (b) applying the coating solution to an inflated balloon catheter, and (c) deflating and folding the balloon catheter and drying the coating solution to increase uniformity of drug coating.

[098] In a further embodiment, the present invention relates to a method for treating a blood vessel. In one aspect of this embodiment, the method comprises inserting a medical device comprising a coating layer into the blood vessel, wherein

the coating layer comprises a therapeutic agent, a contrast agent, and an additive, wherein the additive comprises a hydrophilic part and a drug affinity part, and wherein the therapeutic agent is not enclosed in micelles or liposomes or encapsulated in polymer particles, and releasing the therapeutic agent into the tissue of the blood vessel in 2 minutes or less.

[0099] In a further embodiment, the present invention relates to a method for treating a total occlusion or narrowing of body passages. In one aspect of this embodiment, the method comprises removing plaques in the body passages by one of a debulking catheter, a laser atherectomy, a directing atherectomy, or a rotational atherectomy, inserting a medical device comprising a coating layer into the body passages, wherein the coating layer comprises a therapeutic agent, a contrast agent, and an additive, wherein the additive comprises a hydrophilic part and a drug affinity part, and releasing the therapeutic agent, the contrast agent, and the additive, and delivering the therapeutic agent into the tissue of the body passage or lumen, such as a blood vessel, in 2 minutes or less.

[0100] In a further embodiment, the present invention relates to a method for treating tissue of a body comprising bringing a medical device comprising a coating layer into contact with tissue of the body, wherein the coating layer comprises a therapeutic agent, a contrast agent, and an additive, wherein the additive comprises a hydrophilic part and a drug affinity part, and releasing the therapeutic agent, the contrast agent, and the additive, and delivering the therapeutic agent into the tissue in 2 minutes or less. In one aspect of this embodiment, the tissue includes tissue of one of coronary vasculature, peripheral vasculature, cerebral vasculature, esophagus, airways, sinus, trachea, colon, biliary tract, urinary tract, prostate, and brain passages.

[0101] In yet a further embodiment, the present invention relates to a process of producing a balloon catheter. In one aspect of this embodiment, the process comprises preparing a solution comprising an organic solvent, a therapeutic agent, a contrast agent, and an additive, wherein the additive comprises a hydrophilic part and a drug affinity part, and wherein the therapeutic agent is not enclosed in micelles or liposomes or encapsulated in polymer particles, applying the solution to the balloon catheter, and evaporating the solvent.

[0102] In yet a further embodiment, the present invention relates to a medical device comprising a layer overlying an exterior surface of the medical device, the layer comprising a therapeutic agent, a contrast agent, and an additive, wherein the additive is one of PEG fatty ester, PEG fatty ether, and PEG fatty alcohols. In one aspect of this embodiment, the additive is chosen from PEG-8 laurate, PEG-8 oleate, PEG-8 stearate, PEG-9 oleate, PEG-10 laurate, PEG-10 oleate, PEG-12 laurate, PEG-12 oleate, PEG-15 oleate, PEG-20 laurate, PEG-20 oleate, PEG-20 dilaurate, PEG-20 dioleate, PEG-20 distearate, PEG-32 dilaurate and PEG-32 dioleate. In another aspect of this embodiment, the tissue includes tissue of one of coronary vasculature, peripheral vasculature, cerebral vasculature, esophagus, airways, sinus, trachea, colon, biliary tract, urinary tract, prostate, and brain passages. In yet another aspect of this embodiment, the device includes one of a balloon catheter, a perfusion balloon catheter, an infusion catheter, a cutting balloon catheter, a scoring balloon catheter, a laser catheter, an atherectomy device, a debulking catheter, a stent, a filter, a stent graft, a covered stent, a patch, a wire, and a valve.

[0103] In yet a further embodiment, the present invention relates to a medical device comprising a layer overlying an exterior surface of the medical device, the layer comprising a therapeutic agent, a contrast agent, and an additive, wherein the additive is one of glycerol and polyglycerol fatty esters and PEG glycerol fatty esters. In one aspect of this embodiment, the additive is chosen from polyglyceryl oleate, polyglyceryl-2 dioleate, polyglyceryl-10 trioleate, polyglyceryl stearate, polyglyceryl laurate, polyglyceryl myristate, polyglyceryl palmitate, polyglyceryl linoleate, polyglyceryl-10 laurate, polyglyceryl-10 oleate, polyglyceryl-10 mono, dioleate, polyglyceryl-10 stearate, polyglyceryl-10 laurate, polyglyceryl-10 myristate, polyglyceryl-10 palmitate, polyglyceryl-10 linoleate, polyglyceryl-6 stearate, polyglyceryl-6 laurate, polyglyceryl-6 myristate, polyglyceryl-6 palmitate, and polyglyceryl-6 linoleate, polyglyceryl polyricinoleates, PEG-20 glyceryl laurate, PEG-30 glyceryl laurate, PEG-40 glyceryl laurate, PEG-20 glyceryl oleate, and PEG-30 glyceryl oleate. In another aspect of this embodiment, the tissue includes tissue of one of coronary vasculature, peripheral vasculature, cerebral vasculature, esophagus, airways, sinus, trachea, colon, biliary tract, urinary tract, prostate, and brain passages. In yet another aspect of this embodiment, the device includes one

of a balloon catheter, a perfusion balloon catheter, an infusion catheter, a cutting balloon catheter, a scoring balloon catheter, a laser catheter, an atherectomy device, a debulking catheter, a stent, a filter, a stent graft, a covered stent, a patch, a wire, and a valve.

[0104] In yet a further embodiment, the present invention relates to a medical device comprising a layer overlying an exterior surface of the medical device, the layer comprising a therapeutic agent, a contrast agent, and an additive, wherein the additive is one of sorbitan fatty esters, and PEG sorbitan esters. In one aspect of this embodiment, the additive is chosen from sorbitan monolaurate, sorbitan monopalmitate, sorbitan monooleate, sorbitan monostearate, Tween 20, Tween 40, Tween 60, Tween 80, PEG-20 sorbitan monolaurate, PEG-20 sorbitan monopalmitate, PEG-20 sorbitan monooleate, and PEG-20 sorbitan monostearate. In another aspect of this embodiment, the tissue includes tissue of one of coronary vasculature, peripheral vasculature, cerebral vasculature, esophagus, airways, sinus, trachea, colon, biliary tract, urinary tract, prostate, and brain passages. In yet another aspect of this embodiment, the device includes one of a balloon catheter, a perfusion balloon catheter, an infusion catheter, perforated balloon, porous balloon, weeping balloon, a cutting balloon catheter, a scoring balloon catheter, a laser catheter, an atherectomy device, a debulking catheter, a stent, a filter, a stent graft, a covered stent, a patch, a wire, and a valve.

[0105] In yet a further embodiment, the present invention relates to a medical device comprising a layer overlying an exterior surface of the medical device, the layer comprising a therapeutic agent, a contrast agent, and an additive, wherein the additive is a chemical compound containing a phenol moiety. In one aspect of this embodiment, the additive is chosen from p-isononylphenoxypolyglycidol, octoxynol, monoxynol, tyloxapol, octoxynol-9, and monoxynol-9. In another aspect of this embodiment, the tissue includes tissue of one of coronary vasculature, peripheral vasculature, cerebral vasculature, esophagus, airways, sinus, trachea, colon, biliary tract, urinary tract, prostate, and brain passages. In yet another aspect of this embodiment, the device includes one of a balloon catheter, a perfusion balloon catheter, an infusion catheter, perforated balloon, porous balloon, weeping balloon, a cutting balloon catheter, a scoring balloon catheter, a laser catheter, an

atherectomy device, a debulking catheter, a stent, a filter, a stent graft, a covered stent, a patch, a wire, and a valve.

[0106] In yet a further embodiment, the present invention relates to a medical device comprising a layer overlying an exterior surface of the medical device, the layer comprising a therapeutic agent, a contrast agent, and an additive, wherein the additive is a sugar or sugar derivative. In one aspect of this embodiment, the additive is chosen from sucrose monolaurate, decanoyl-N-methylglucamide, n-decyl - β -D-glucopyranoside, n-decyl - β -D-maltopyranoside, n-dodecyl - β -D-glucopyranoside, n-dodecyl - β -D-maltoside, heptanoyl-N-methylglucamide, n-heptyl - β -D-glucopyranoside, n-heptyl - β -D-thiogluconoside, n-hexyl - β -D-glucopyranoside, nonanoyl-N-methylglucamide, n-nonyl - β -D-glucopyranoside, octanoyl-N-methylglucamide, n-octyl - β -D-glucopyranoside, octyl - β -D-thiogluconopyranoside, D-glucoascorbic acid and its salt, triethanolamine, diethanolamine, meglumine, tromethamine, glucamine, glucosamine, glucoheptonic acid, gluconic acid, hydroxyl ketone, hydroxyl lactone, gluconolactone, glucoheptonolactone, glucooctanoic lactone, gulonic acid lactone, mannoic lactone, ribonic acid lactone, lactobionic acid, , glucosamine, glutamic acid, benzyl alcohol, benzoic acid, hydroxybenzoic acid, vanillin, vanillic acid, vanillic acid diethylamide, lysine acetate salt, gentisic acid, lactobionic acid, lactitol, diethylene glycol, triethylene glycol, tetraethylene glycol, xylitol, 2-ethoxyethanol, sugars, galactose, glucose, mannose, xylose, sucrose, lactose, maltose, sorbitol, cyclodextrin, (2-hydroxypropyl)-cyclodextrin, acetaminophen, ibuprofen, catechin, catechin gallate, methyl paraben, ethyl paraben, propyl paraben, butyl paraben, tiletamine, ketamine, propofol, lactic acids, acetic acid, salts of any organic acid and amine described above. In another aspect of this embodiment, the tissue includes tissue of one of coronary vasculature, peripheral vasculature, cerebral vasculature, esophagus, airways, sinus, trachea, colon, biliary tract, urinary tract, prostate, and brain passages. In yet another aspect of this embodiment, the device includes one of a balloon catheter, a perfusion balloon catheter, an infusion catheter, a cutting balloon catheter, a scoring balloon catheter, a laser catheter, an atherectomy device, a debulking catheter, a stent, a filter, a stent graft, a covered stent, a patch, a wire, and a valve.

[0107] In yet a further embodiment, the present invention relates to a medical device comprising a layer overlying an exterior surface of the medical device, the layer comprising a therapeutic agent, a contrast agent, and an additive, wherein the additive is an ionic surfactant. In one aspect of this embodiment, the additive is chosen from benzalkonium chloride, benzethonium chloride, cetylpyridinium chloride, docecyl trimethyl ammonium bromide, sodium docecylsulfates, dialkyl methylbenzyl ammonium chloride, edrophonium chloride, domiphen bromide, and dialkylesters of sodium sulfonsuccinic acid, sodium dioctyl sulfosuccinate, sodium cholate, and sodium taurocholate. In another aspect of this embodiment, the tissue includes tissue of one of coronary vasculature, peripheral vasculature, cerebral vasculature, esophagus, airways, sinus, trachea, colon, biliary tract, urinary tract, prostate, and brain passages. In yet another aspect of this embodiment, the device includes one of a balloon catheter, a perfusion balloon catheter, an infusion catheter, perforated balloon, porous balloon, weeping balloon, a cutting balloon catheter, a scoring balloon catheter, a laser catheter, an atherectomy device, a debulking catheter, a stent, a filter, a stent graft, a covered stent, a patch, a wire, and a valve.

[0108] Many embodiments of the present invention are particularly useful for treating vascular disease and for reducing stenosis and late luminal loss, or are useful in the manufacture of devices for that purpose.

[0109] It is understood that both the foregoing general description and the following detailed description are exemplary and explanatory only and are not restrictive of the present invention as claimed.

BRIEF DESCRIPTION OF THE DRAWINGS

[0110] Figure 1 is a perspective view of an exemplary embodiment of a balloon catheter according to the present invention.

[0111] Figures 2A-2C are cross-sectional views of different embodiments of the distal portion of the balloon catheter of Fig. 1, taken along line A-A, showing exemplary coating layers.

DETAILED DESCRIPTION OF EXEMPLARY EMBODIMENTS

[0112] Embodiments of the present invention relate to medical devices, including particularly balloon catheters and stents, having a rapid drug-releasing coating and methods for preparing such coated devices. The therapeutic agent

according to embodiments of the present invention does not require a delayed or long term release and instead preferably is released in a very short time period, from seconds to minutes, to provide a therapeutic effect upon contact with tissue. An object of embodiments of the present invention is to facilitate rapid and efficient uptake of drug by target tissue during transitory device deployment at a target site.

[0113] As shown in Fig. 1, in one embodiment, the medical device is a balloon catheter. The balloon catheter may be any suitable catheter for the desired use, including conventional balloon catheters known to one of ordinary skill in the art. For example, balloon catheter 10 may include an expandable, inflatable balloon 12 at a distal end of the catheter 10, a handle assembly 16 at a proximal end of the catheter 10, and an elongate flexible member 14 extending between the proximal and distal ends. Handle assembly 16 may connect to and/or receive one or more suitable medical devices, such as a source of inflation media (e.g., air, saline, or contrast media). Flexible member 14 may be a tube made of suitable biocompatible material and having one or more lumens therein. At least one of the lumens is configured to receive inflation media and pass such media to balloon 12 for its expansion. The balloon catheter may be a rapid exchange or over-the-wire catheter and made of any suitable biocompatible material.

[0114] In one embodiment, the present invention provides a medical device for delivering a therapeutic agent to a tissue. The device includes a layer applied to an exterior surface of the medical device, such as a balloon catheter or stent, for example. The layer includes a therapeutic agent, a contrast agent, and an additive. For example, as shown in the embodiment depicted in Fig. 2A, the balloon 12 is coated with a layer 20 that includes a therapeutic agent, a contrast agent, and an additive. In some embodiments, the layer consists essentially of a therapeutic agent, a contrast agent, and an additive, i.e., the layer includes only the therapeutic agent, the contrast agent, and the additive, without any other materially significant components. In some embodiments, the device may optionally include an adherent layer. For example, as shown in the embodiment depicted in Fig. 2B, the balloon 12 is coated with an adherent layer 22. A layer 24 that includes a therapeutic agent, a contrast agent, and an additive is overlying the adherent layer. The adherent layer, which is a separate layer underlying the drug coating layer, improves the adherence of the drug coating layer to the exterior surface of the

medical device and protects coating integrity. For example, if the therapeutic agent, contrast agent, and additive differ in their adherence to the medical device, the adherent layer may prevent differential loss of components and maintain drug-to-additive ratio and drug-to-contrast agent ratio in the coating during transit to a target site for therapeutic intervention. Furthermore, the adherent layer may function to facilitate rapid release of coating layer components off the device surface upon contact with tissues at the target site. In other embodiments, the device may include a top layer. The top layer may prevent loss of the drug layer before it is brought into contact with target tissues, for example during transit of the balloon 12 to the site of therapeutic intervention or during the first moments of inflation of balloon 12 before coating layer 20 is pressed into direct contact with target tissue. In one embodiment, the therapeutic agent in the coating layer is lipophilic or water-insoluble.

[0115] In embodiments of the coatings for medical devices of the present invention, the lipophilic or water-insoluble therapeutic agent is interdispersed in the matrix or dispersion of the contrast agent and the additive in the coating layer overlying the medical device.

[0116] In one embodiment, the concentration density of the at least one therapeutic agent applied to the surface of the medical device is from about 1 to 20 $\mu\text{g}/\text{mm}^2$, or more preferably from about 2 to 6 $\mu\text{g}/\text{mm}^2$. In one embodiment, the ratio by weight of the therapeutic agent to the contrast agent in the layer is from about 0.05 to 100, for example, from about 0.1 to 5, from 0.5 to 3, and further for example, from about 0.8 to 1.2. In one embodiment, the ratio by weight of the drug to the additive in the layer is from about 0.05 to 100, for example, from about 0.1 to 5, from 0.5 to 2, and further for example, from about 0.8 to 1.2

[0117] In other embodiments, the layer may include a therapeutic agent, a contrast agent, and more than one additive. For example, one additive may serve to improve balloon adhesion of the contrast agent or of another additive that is superior at promoting tissue uptake of drug. Alternatively, one additive may decrease balloon adhesion of another additive, in order to accelerate elution of the therapeutic agent off the surface of the device during brief deployment at the target site.

[0118] In another embodiment, the device comprises two layers applied to an exterior surface of the medical device, and particularly a balloon catheter, for example. The first layer comprises a therapeutic agent. The first layer may optionally comprise a contrast agent and an additive or additives. The second layer comprises a contrast agent and an additive or additives. The second layer may optionally include at least a therapeutic agent. When the first and second layers both contain a therapeutic agent, the content of the therapeutic agent in the second layer is lower than the content of the therapeutic agent in the first layer. In one embodiment, the second layer is overlying the first layer. In this arrangement, the second layer can prevent drug loss during deployment of the medical device into body passageways, for example, as a balloon catheter traverses the tortuous anatomy to a tissue site in the vasculature.

[0119] In another embodiment, the device comprises two layers applied to an exterior surface of the medical device, and particularly a balloon catheter, for example. The first layer comprises a therapeutic agent. The first layer may optionally comprise a contrast agent and an additive or additives. The second layer comprises a contrast agent and an additive or additives. The second layer may optionally include at least a therapeutic agent. When the first and second layers both contain a therapeutic agent, the content of the therapeutic agent in the first layer is lower than the content of the therapeutic agent in the second layer. In one embodiment, the second layer is overlying the first layer. This arrangement is useful, for example, in the case of a therapeutic agent that adheres too tightly to the balloon surface to rapidly elute off the balloon when inflated at the target site. In this arrangement, the first layer functions to facilitate rapid release of the bulk of drug, which is in the second layer, off the surface of the device while it is inflated at the target site of therapeutic intervention.

[0120] In other embodiments, two or more therapeutic agents are used in combination in the drug-additive and contrast agent layer.

[0121] In a further embodiment, the device having a two layer coating may optionally include an adherent layer. The adherent layer does not contain a therapeutic agent. For example, as shown in the embodiment depicted in Fig. 2C, the balloon 12 is coated with an adherent layer 22. A first layer 26 that comprises a therapeutic agent and optionally a contrast agent and an additive or additives is

overlying the adherent layer 22. A second layer 28 that comprises a contrast agent and an additive and optionally a therapeutic agent is overlying the first layer 26. The adherent layer improves the adherence of the first layer to the exterior surface of the medical device and protects the integrity of the first layer. For example, if drug, contrast agent, and additive or additives in the first layer differ in their strength of adherence to the medical device, the adherent layer may prevent differential loss of components and maintain drug-to-additive, drug-to-contrast agent ratio, contrast agent-to-additive ratio, and additive-to-additive ratio in the first and second layers during transit to a target site for therapeutic intervention. Furthermore, the adherent layer may function to facilitate rapid elution of coating layer off the device surface upon contact with tissues at the target site. In one embodiment, the first layer, the second layer, and the adherent layer each contain an additive or contrast agent.

[0122] Optionally, post-treatment with dimethylsulfoxide (DMSO) or other solvent may be advantageous since DMSO may further enhance penetration and absorption of drug into tissue. DMSO displaces water from the lipid head groups and protein domains of the membrane lipid bilayer of target cells to indirectly loosen the lipid structure, accelerating drug absorption and penetration.

[0123] In a further embodiment, the present invention relates to a pharmaceutical composition for treating a diseased body lumen or cavities after surgical or interventional procedures (PTCA, PTA, stent placement, excision of diseased tissue such as cancer, and relieving or treating stenosis), wherein the pharmaceutical composition comprises a therapeutic agent, a contrast agent, and an additive, wherein the additive comprises a hydrophilic part and a drug affinity part, wherein the drug affinity part is a hydrophobic part and/or has an affinity to the therapeutic agent by hydrogen bonding and/or van der Waals interactions, and wherein the therapeutic agent is not enclosed in micelles or liposomes or encapsulated in polymer particles.

[0124] In another embodiment, a method of preventing complications or recurrence of disease (such as cancer or restenosis) after a surgical or interventional procedure such as PTCA, PTA, stent deployment, stenosis or plaque removal by debulking, atherectomy, or laser procedures, the pharmaceutical composition is locally delivered at or near the site of intervention by means of a coated medical device (such as a drug-coated balloon), or by spray, by injection, or

by deposition. For example, the pharmaceutical composition may be delivered by spray, injection, balloon or other method of deposition, into cavities created by surgical removal of cancer tissue in order to reduce the risk of recurrence. As another example, a method for delivering the pharmaceutical composition comprises inserting a medical device (such as guide catheter or a drug infusion catheter) into the blood to inject the pharmaceutical composition after a vascular intervention such as PTCA, PTA, or stent placement to prevent restenosis, wherein the pharmaceutical composition comprises a therapeutic agent, a contrast agent, and an additive, wherein the additive comprises a hydrophilic part and a drug affinity part, wherein the drug affinity part is a hydrophobic part and/or has an affinity to the therapeutic agent by hydrogen bonding and/or Van der Waals interactions, and wherein the therapeutic agent is not enclosed in micelles or liposomes or encapsulated in polymer particles.

[0125] Many embodiments of the present invention are particularly useful for treating vascular disease and for reducing stenosis and late luminal loss, or are useful in the manufacture of devices for that purpose.

[0126] Contrast Agent

[0127] X-ray contrast agents for intravascular injection are based upon the triiodobenzene ring substituted with two or three additional hydrophilic groups. In the case of biliary contrast agents (compounds that are taken up by the liver and excreted mainly by the biliary tract), two hydrophilic groups are introduced. For angiographic/urographic agents (compounds that stay within the extravascular distribution volume and are excreted by the kidneys), three hydrophilic groups are introduced. The monomers are exclusively derived from aminoisophthalic acid. They only differ by their side-chains, which determine their physiochemical characteristics such as solubility, hydrophilicity, viscosity, and osmolality. Many of these agents contain covalently-bonded iodine. The aqueous solubility of X-ray contrast agents is generally extremely high being in the order of 1000 mg/ml. Most preparations of X-ray contrast agents are over-saturated solutions.

[0128] The contrast agent in embodiments of the present invention includes iobitridol, iohexol, iomeprol, iopamidol, iopentol, iopromide, ioversol, ioxilan, iotrolan, iodixanol, ioxaglate, and their derivatives. These are provided by

way of example, and there are many other contrast agents known in the art that are useful in embodiments of the present invention.

[0129] Additive

[0130] The additive of embodiments of the present invention has two parts. One part is hydrophilic and the other part is a drug affinity part. The drug affinity part is a hydrophobic part and/or has affinity to the therapeutic agent by hydrogen bonding and/or charge and/or van der Waals interactions. The drug affinity part of the additive may bind the lipophilic drug, such as rapamycin or paclitaxel. In embodiments of the present invention, the additive is interdispersed with the lipophilic or water-insoluble drug and the contrast agent in the coating of a medical device. By nature of its two parts, the additives of embodiments of the present invention have affinity to both the hydrophilic contrast agent and to the lipophilic or water-insoluble therapeutic agent. The additive improves the compatability of the therapeutic agent and the contrast agent in the coating solution and coating layer. The additive improves the physical properties of the coating, its ability to resist flaking or physical disruption, and it improves and preserves coating integrity and uniformity and consistency of drug distribution in the coating.

[0131] The hydrophilic portion may also function to accelerate diffusion and increase permeation of the drug into tissue. It may facilitate rapid movement of drug off the medical device during deployment at the target site by preventing hydrophobic drug molecules from clumping to each other and to the surface of the device, increasing drug solubility in interstitial spaces, and/or accelerating drug passage through polar head groups to the lipid bilayer of cell membranes of target tissues.

[0132] The additives of embodiments of the present invention have two parts that function together to improve the compatability of contrast agent with the therapeutic agent in the coating and to improve the physical properties of the coating. Since one part of the additive has affinity to contrast agent and the other part has affinity to lipophilic or water-insoluble drug, the additives of embodiments of the present invention improve the compatability of these agents in the coating layer. The additives thereby improve the coating layer's resistance to physical disruption and the uniformity and consistency of drug distribution in and integrity of the coating. The additives of embodiments of the present invention may also

facilitate rapid release of drug off the device surface and uptake by target tissue during deployment (by accelerating drug contact with tissues for which drug has high affinity) while preventing the premature release of drug from the device surface prior to device deployment at the target site.

[0133] In embodiments of the present invention, the therapeutic agent, the contrast agent, and additive are rapidly released after the medical device is brought into contact with tissue, and the therapeutic agent is readily absorbed by tissue. For example, certain embodiments of devices of the present invention include drug coated balloon catheters that deliver a lipophilic anti-proliferative pharmaceutical (such as paclitaxel or rapamycin) to vascular tissue through brief, direct pressure contact at high drug concentration during balloon angioplasty. The lipophilic drug is preferentially retained in target tissue at the delivery site, where it inhibits hyperplasia and restenosis yet allows endothelialization. In these embodiments, coating formulations of the present invention not only facilitate rapid release of drug from the balloon surface and transfer of drug into target tissues during deployment, but also prevent drug from diffusing away from the device during transit through tortuous arterial anatomy prior to reaching the target site and from exploding off the device during the initial phase of balloon inflation, before the drug coating is pressed into direct contact with the surface of the vessel wall.

[0134] The additive according to certain embodiments, has a drug affinity part and a hydrophilic part. The drug affinity part is a hydrophobic part and/or has an affinity to the therapeutic agent by hydrogen bonding and/or van der Waals interactions. The drug affinity part may include aliphatic and aromatic organic hydrocarbon compounds, such as benzene, toluene, and alkanes, among others. These parts are not water soluble. They may bind both hydrophobic drug, with which they share structural similarities, and lipids of cell membranes. The drug affinity part may include functional groups that can form hydrogen bonds with drug and with itself. The hydrophilic part may include hydroxyl groups, amine groups, amide groups, carbonyl groups, carboxylic acid and anhydrides, ethyl oxide, ethyl glycol, polyethylene glycol, ascorbic acid, amino acid, amino alcohol, glucose, sucrose, sorbitan, glycerol, polyalcohol, phosphates, sulfates, organic salts and their substituted molecules, among others. One or more hydroxyl, carboxyl, acid, amide or amine groups, for example, may be advantageous since they easily

displace water molecules that are hydrogen-bound to polar head groups and surface proteins of cell membranes and may function to remove this barrier between hydrophobic drug and cell membrane lipid. These parts can dissolve in water and polar solvents. These additives are not oils, lipids, or polymers. The therapeutic agent is not enclosed in micelles or liposomes or encapsulated in polymer particles. The additives of embodiments of the present invention have components to both bind drug and contrast agent, improving the physical properties of the coating and facilitating the rapid movement of drug off the surface of the medical device during deployment and into target tissues.

[0135] The additives in embodiments of the present invention are surfactants and chemical compounds with one or more hydroxyl, amino, carbonyl, carboxyl, acid, amide or ester moieties. The surfactants include ionic, nonionic, aliphatic, and aromatic surfactants. The chemical compounds with one or more hydroxyl, amino, carbonyl, carboxyl, acid, amide or ester moieties are chosen from amino alcohols, hydroxyl carboxylic acid and anhydrides, ethyl oxide, ethyl glycols, amino acids, peptides, proteins, sugars, glucose, sucrose, sorbitan, glycerol, polyalcohol, phosphates, sulfates, organic acids, esters, salts, vitamins, and their substituted molecules.

[0136] As is well known in the art, the terms "hydrophilic" and "hydrophobic" are relative terms. To function as an additive in exemplary embodiments of the present invention, the compound includes polar or charged hydrophilic moieties and moieties with affinity to the therapeutic agent, such as nonpolar, hydrophobic or lipophilic moieties or moieties that form hydrogen bonds and/or van der Waals interactions with drug.

[0137] An empirical parameter commonly used in medicinal chemistry to characterize the relative hydrophilicity and hydrophobicity of pharmaceutical compounds is the partition coefficient, P , the ratio of concentrations of unionized compound in the two phases of a mixture of two immiscible solvents, usually octanol and water, such that $P = ([\text{solute}]_{\text{octanol}} / [\text{solute}]_{\text{water}})$. Compounds with higher $\log P$ s are more hydrophobic, while compounds with lower $\log P$ s are more hydrophilic. Lipinski's rule suggests that pharmaceutical compounds having $\log P < 5$ are typically more membrane permeable. For purposes of certain embodiments of the present invention, it is preferable that the additive has $\log P$ less than $\log P$ of

the drug to be formulated (as an example, log P of paclitaxel is 7.4). A greater log P difference between the drug and the additive can facilitate phase separation of drug. For example, if log P of the additive is much lower than log P of the drug, the additive may accelerate the release of drug in an aqueous environment from the surface of a device to which drug might otherwise tightly adhere, thereby accelerating drug delivery to tissue during brief deployment at the site of intervention. In certain embodiments of the present invention, log P of the additive is negative. In other embodiments, log P of the additive is less than log P of the drug. While a compound's octanol-water partition coefficient P or log P is useful as a measurement of relative hydrophilicity and hydrophobicity, it is merely a rough guide that may be useful in defining suitable additives for use in embodiments of the present invention.

[0138] Suitable additives that can be used in embodiments of the present invention include, without limitation, organic and inorganic pharmaceutical excipients, natural products and derivatives thereof (such as sugars, vitamins, amino acids, peptides, proteins, and fatty acids), low molecular weight oligomers, surfactants (anionic, cationic, non-ionic, and ionic), and mixtures thereof. The following detailed list of additives useful in the present invention is provided for exemplary purposes only and is not intended to be comprehensive. Many other additives may be useful for purposes of the present invention.

[0139] Surfactants

[0140] The surfactant can be any surfactant suitable for use in pharmaceutical compositions. Such surfactants can be anionic, cationic, zwitterionic or non-ionic. Mixtures of surfactants are also within the scope of the invention, as are combinations of surfactant and other additives. Surfactants often have one or more long aliphatic chains such as fatty acids that may insert directly into lipid bilayers of cell membranes to form part of the lipid structure, while other components of the surfactants loosen the lipid structure and enhance drug penetration and absorption.

[0141] An empirical parameter commonly used to characterize the relative hydrophilicity and hydrophobicity of surfactants is the hydrophilic-lipophilic balance ("HLB" value). Surfactants with lower HLB values are more hydrophobic, and have greater solubility in oils, while surfactants with higher HLB values are more

hydrophilic, and have greater solubility in aqueous solutions. Using HLB values as a rough guide, hydrophilic surfactants are generally considered to be those compounds having an HLB value greater than about 10, as well as anionic, cationic, or zwitterionic compounds for which the HLB scale is not generally applicable. Similarly, hydrophobic surfactants are compounds having an HLB value less than about 10. In certain embodiments of the present invention, a higher HLB value is preferred, since increased hydrophilicity may facilitate release of hydrophobic drug from the surface of the device. In one embodiment, the HLB of the surfactant additive is higher than 10. In another embodiment, the additive HLB is higher than 14. Alternatively, surfactants having lower HLB may be preferred when used to prevent drug loss prior to device deployment at the target site, for example in a top coat over a drug layer that has a very hydrophilic additive.

[0142] It should be understood that the HLB value of a surfactant is merely a rough guide generally used to enable formulation of industrial, pharmaceutical and cosmetic emulsions, for example. For many important surfactants, including several polyethoxylated surfactants, it has been reported that HLB values can differ by as much as about 8 HLB units, depending upon the empirical method chosen to determine the HLB value (Schott, J. Pharm. Sciences, 79(1), 87-88 (1990)). Keeping these inherent difficulties in mind, and using HLB values as a guide, surfactants may be identified that have suitable hydrophilicity or hydrophobicity for use in embodiments of the present invention, as described herein.

[0143] PEG- Fatty Acids and PEG-Fatty Acid Mono and Diesters

[0144] Although polyethylene glycol (PEG) itself does not function as a surfactant, a variety of PEG-fatty acid esters have useful surfactant properties. Among the PEG-fatty acid monoesters, esters of lauric acid, oleic acid, and stearic acid are most useful in embodiments of the present invention. Preferred hydrophilic surfactants include PEG-8 laurate, PEG-8 oleate, PEG-8 stearate, PEG-9 oleate, PEG-10 laurate, PEG-10 oleate, PEG-12 laurate, PEG-12 oleate, PEG-15 oleate, PEG-20 laurate and PEG-20 oleate. The HLB values are in the range of 4-20.

[0145] Polyethylene glycol fatty acid diesters are also suitable for use as surfactants in the compositions of embodiments of the present invention. Most preferred hydrophilic surfactants include PEG-20 dilaurate, PEG-20 dioleate, PEG-

20 distearate, PEG-32 dilaurate and PEG-32 dioleate. The HLB values are in the range of 5-15.

[0146] In general, mixtures of surfactants are also useful in embodiments of the present invention, including mixtures of two or more commercial surfactants as well as mixtures of surfactants with another additive or additives. Several PEG-fatty acid esters are marketed commercially as mixtures or mono- and diesters.

[0147] Polyethylene Glycol Glycerol Fatty Acid Esters

[0148] Preferred hydrophilic surfactants are PEG-20 glyceryl laurate, PEG-30 glyceryl laurate, PEG-40 glyceryl laurate, PEG-20 glyceryl oleate, and PEG-30 glyceryl oleate.

[0149] Alcohol-Oil Transesterification Products

[0150] A large number of surfactants of different degrees of hydrophobicity or hydrophilicity can be prepared by reaction of alcohols or polyalcohol with a variety of natural and/or hydrogenated oils. Most commonly, the oils used are castor oil or hydrogenated castor oil, or an edible vegetable oil such as corn oil, olive oil, peanut oil, palm kernel oil, apricot kernel oil, or almond oil. Preferred alcohols include glycerol, propylene glycol, ethylene glycol, polyethylene glycol, sorbitol, and pentaerythritol. Among these alcohol-oil transesterified surfactants, preferred hydrophilic surfactants are PEG-35 castor oil (Incrocas-35), PEG-40 hydrogenated castor oil (Cremophor RH 40), PEG-25 trioleate (TAGAT.RTM. TO), PEG-60 corn glycerides (Crovol M70), PEG-60 almond oil (Crovol A70), PEG-40 palm kernel oil (Crovol PK70), PEG-50 castor oil (Emalex C-50), PEG-50 hydrogenated castor oil (Emalex HC-50), PEG-8 caprylic /capric glycerides (Labrasol), and PEG-6 caprylic /capric glycerides (Softigen 767). Preferred hydrophobic surfactants in this class include PEG-5 hydrogenated castor oil, PEG-7 hydrogenated castor oil, PEG-9 hydrogenated castor oil, PEG-6 corn oil (Labrafil.RTM. M 2125 CS), PEG-6 almond oil (Labrafil.RTM. M 1966 CS), PEG-6 apricot kernel oil (Labrafil.RTM. M 1944 CS), PEG-6 olive oil (Labrafil.RTM. M 1980 CS), PEG-6 peanut oil (Labrafil.RTM. M 1969 CS), PEG-6 hydrogenated palm kernel oil (Labrafil.RTM. M 2130 BS), PEG-6 palm kernel oil (Labrafil.RTM. M 2130 CS), PEG-6 triolein (Labrafil.RTM.b M 2735 CS), PEG-8 corn oil (Labrafil.RTM. WL 2609 BS), PEG-20 corn glycerides (Crovol M40), and PEG-20 almond glycerides (Crovol A40).

[0151] Polyglyceryl Fatty Acids

[0152] Polyglycerol esters of fatty acids are also suitable surfactants for use in embodiments of the present invention. Among the polyglyceryl fatty acid esters, preferred hydrophobic surfactants include polyglyceryl oleate (Plurol Oleique), polyglyceryl-2 dioleate (Nikkol DGDO), polyglyceryl-10 trioleate, polyglyceryl stearate, polyglyceryl laurate, polyglyceryl myristate, polyglyceryl palmitate, and polyglyceryl linoleate. Preferred hydrophilic surfactants include polyglyceryl-10 laurate (Nikkol Decaglyn 1-L), polyglyceryl-10 oleate (Nikkol Decaglyn 1-O), and polyglyceryl-10 mono, dioleate (Caprol.RTM. PEG 860), polyglyceryl-10 stearate, polyglyceryl-10 laurate, polyglyceryl-10 myristate, polyglyceryl-10 palmitate, polyglyceryl-10 linoleate, polyglyceryl-6 stearate, polyglyceryl-6 laurate, polyglyceryl-6 myristate, polyglyceryl-6 palmitate, and polyglyceryl-6 linoleate. Polyglyceryl polyricinoleates (Polymuls) are also preferred surfactants.

[0153] Propylene Glycol Fatty Acid Esters

[0154] Esters of propylene glycol and fatty acids are suitable surfactants for use in embodiments of the present invention. In this surfactant class, preferred hydrophobic surfactants include propylene glycol monolaurate (Lauroglycol FCC), propylene glycol ricinoleate (Propymuls), propylene glycol monooleate (Myverol P-O6), propylene glycol dicaprylate/dicaprate (Captex.RTM. 200), and propylene glycol dioctanoate (Captex.RTM. 800).

[0155] Sterol and Sterol Derivatives

[0156] Sterols and derivatives of sterols are suitable surfactants for use in embodiments of the present invention. Preferred derivatives include the polyethylene glycol derivatives. A preferred surfactant in this class is PEG-24 cholesterol ether (Solulan C-24).

[0157] Polyethylene Glycol Sorbitan Fatty Acid Esters

[0158] A variety of PEG-sorbitan fatty acid esters are available and are suitable for use as surfactants in embodiments of the present invention. Among the PEG-sorbitan fatty acid esters, preferred surfactants include PEG-20 sorbitan monolaurate (Tween-20), PEG-20 sorbitan monopalmitate (Tween-40), PEG-20 sorbitan monostearate (Tween-60), and PEG-20 sorbitan monooleate (Tween-80). Laurate esters are preferred because they have a short lipid chain compared with oleate esters, increasing drug absorption.

[0159] Polyethylene Glycol Alkyl Ethers

[0160] Ethers of polyethylene glycol and alkyl alcohols are suitable surfactants for use in embodiments of the present invention. Preferred ethers include PEG-3 oleyl ether (Volpo 3) and PEG-4 lauryl ether (Brij 30).

[0161] Sugar and Its Derivatives

[0162] Sugar derivatives are suitable surfactants for use in embodiments of the present invention. Preferred surfactants in this class include sucrose monopalmitate, sucrose monolaurate, decanoyl-N-methylglucamide, n-decyl - β -D-glucopyranoside, n-decyl - β -D-maltopyranoside, n-dodecyl - β -D-glucopyranoside, n-dodecyl - β -D-maltoside, heptanoyl-N-methylglucamide, n-heptyl - β -D-glucopyranoside, n-heptyl - β -D-thioglucoside, n-hexyl - β -D-glucopyranoside, nonanoyl-N-methylglucamide, n-nonyl - β -D-glucopyranoside, octanoyl-N-methylglucamide, n-octyl - β -D-glucopyranoside, and octyl - β -D-thioglucopyranoside.

[0163] Polyethylene Glycol Alkyl Phenols

[0164] Several PEG-alkyl phenol surfactants are available, such as PEG-10-100 nonyl phenol and PEG-15-100 octyl phenol ether, Tyloxapol, octoxynol, nonoxynol, and are suitable for use in embodiments of the present invention.

[0165] Polyoxyethylene-Polyoxypropylene (POE-POP) Block Copolymers

[0166] The POE-POP block copolymers are a unique class of polymeric surfactants. The unique structure of the surfactants, with hydrophilic POE and hydrophobic POP moieties in well-defined ratios and positions, provides a wide variety of surfactants suitable for use in embodiments of the present invention. These surfactants are available under various trade names, including Synperonic PE series (ICI); Pluronic.RTM. series (BASF), Emkalyx, Lutrol (BASF), Supronic, Monolan, Pluracare, and Plurodac. The generic term for these polymers is "poloxamer" (CAS 9003-11-6). These polymers have the formula:

[0167] $\text{HO}(\text{C}_2\text{H}_4\text{O})_a(\text{C}_3\text{H}_6\text{O})_b(\text{C}_2\text{H}_4\text{O})_a\text{H}$ where "a" and "b" denote the number of polyoxyethylene and polyoxypropylene units, respectively.

[0168] Preferred hydrophilic surfactants of this class include Poloxamers 108, 188, 217, 238, 288, 338, and 407. Preferred hydrophobic surfactants in this class include Poloxamers 124, 182, 183, 212, 331, and 335.

[0169] Sorbitan Fatty Acid Esters

[0170] Sorbitan esters of fatty acids are suitable surfactants for use in embodiments of the present invention. Among these esters, preferred hydrophobic surfactants include sorbitan monolaurate (Arlacel 20), sorbitan monopalmitate (Span-40), and sorbitan monooleate (Span-80), sorbitan monostearate.

[0171] The sorbitan monopalmitate, an amphiphilic derivative of Vitamin C (which has Vitamin C activity), can serve two important functions in solubilization systems. First, it possesses effective polar groups that can modulate the microenvironment. These polar groups are the same groups that make vitamin C itself (ascorbic acid) one of the most water-soluble organic solid compounds available: ascorbic acid is soluble to about 30 wt/wt % in water (very close to the solubility of sodium chloride, for example). And second, when the pH increases so as to convert a fraction of the ascorbyl palmitate to a more soluble salt, such as sodium ascorbyl palmitate.

[0172] Ionic Surfactants

[0173] Ionic surfactants, including cationic, anionic and zwitterionic surfactants, are suitable hydrophilic surfactants for use in embodiments of the present invention. Preferred ionic surfactants include quaternary ammonium salts, fatty acid salts and bile salts. Specifically, preferred ionic surfactants include benzalkonium chloride, benzethonium chloride, cetylpyridinium chloride, docecyl trimethyl ammonium bromide, sodium docecylsulfates, dialkyl methylbenzyl ammonium chloride, edrophonium chloride, domiphen bromide, dialkylesters of sodium sulfonsuccinic acid, sodium dioctyl sulfosuccinate, sodium cholate, and sodium taurocholate. These quaternary ammonium salts are preferred additives. They can be dissolved in both organic solvents (such as ethanol, acetone, and toluene) and water. This is especially useful for medical device coatings because it simplifies the preparation and coating process and has good adhesive properties. Water insoluble drugs are commonly dissolved in organic solvents.

[0174] Chemical compounds with one or more hydroxyl, amino, carbonyl, carboxyl, acid, amide or ester moieties

[0175] The chemical compounds with one or more hydroxyl, amino, carbonyl, carboxyl, acid, amide or ester moieties include amino alcohols, hydroxyl carboxylic acid, ester, and anhydrides, hydroxyl ketone, hydroxyl lactone, hydroxyl ester,

sugar phosphate, sugar sulfate, ethyl oxide, ethyl glycols, amino acids, peptides, proteins, sorbitan, glycerol, polyalcohol, phosphates, sulfates, organic acids, esters, salts, vitamins, combinations of amino alcohols and organic acids, and their substituted molecules. Hydrophilic chemical compounds with one or more hydroxyl, amino, carbonyl, carboxyl, acid, amide or ester moieties having molecular weight less than 5,000-10,000 are preferred in certain embodiments. In other embodiments, molecular weight of the additive with one or more hydroxyl, amino, carbonyl, carboxyl, acid, amide, or ester moieties is preferably less than 1000-5,000, or more preferably less than 750-1,000, or most preferably less than 750. In these embodiments, the molecular weight of the additive is preferred to be less than that of the drug to be delivered. The molecular weight of the additive is preferred to be higher than 80 since molecules with molecular weight less than 80 very easily evaporate and do not stay in the coating of a medical device. Small molecules can diffuse quickly. They can release themselves easily from the delivery balloon, accelerating release of drug, and they can diffuse away from drug when the drug binds tissue of the body lumen.

[0176] Fat-soluble Vitamins and Salts Thereof

[0177] Vitamins A, D, E and K in many of their various forms and provitamin forms are considered as fat-soluble vitamins and in addition to these a number of other vitamins and vitamin sources or close relatives are also fat-soluble and have polar groups, and relatively high octanol-water partition coefficients. Clearly, the general class of such compounds has a history of safe use and high benefit to risk ratio, making them useful as additives in embodiments of the present invention.

[0178] The following examples of fat-soluble vitamin derivatives and/or sources are also useful as additives: Alpha-tocopherol, beta-tocopherol, gamma-tocopherol, delta-tocopherol, tocopherol acetate, ergosterol, 1-alpha-hydroxycholecal- ciferol, vitamin D2, vitamin D3, alpha-carotene, beta-carotene, gamma-carotene, vitamin A, fursultiamine, methylolriboflavin, octotiamine, prosultiamine, riboflavine, vintiamol, dihydrovitamin K1, menadiol diacetate, menadiol dibutyrate, menadiol disulfate, menadiol, vitamin K1, vitamin K1 oxide, vitamins K2, and vitamin K--S(II). Folic acid is also of this type, and although it is water-soluble at physiological pH, it can be formulated in the free acid form. Other derivatives of fat-soluble vitamins useful in embodiments of the present invention

may easily be obtained via well known chemical reactions with hydrophilic molecules.

[0179] Water-soluble Vitamins and Their Amphiphilic Derivatives

[0180] Vitamins B, C, U, pantothenic acid, folic acid, and some of the menadione-related vitamins/provitamins in many of their various forms are considered water-soluble vitamins. These may also be conjugated or complexed with hydrophobic moieties or multivalent ions into amphiphilic forms having relatively high octanol-water partition coefficients and polar groups. Again, such compounds can be of low toxicity and high benefit to risk ratio, making them useful as additives in embodiments of the present invention. Salts of these can also be useful as additives in the present invention. Examples of water-soluble vitamins and derivatives include, without limitation, acetiamine, benfotiamine, pantothenic acid, cetotiamine, cycothiamine, dexpanthenol, niacinamide, nicotinic acid, pyridoxal 5-phosphate, nicotinamide ascorbate, riboflavin, riboflavin phosphate, thiamine, folic acid, menadiol diphosphate, menadione sodium bisulfite, menadoxime, vitamin B12, vitamin K5, vitamin K6, vitamin K6, and vitamin U. Also, as mentioned above, folic acid is, over a wide pH range including physiological pH, water-soluble, as a salt.

[0181] Compounds in which an amino or other basic group is present can easily be modified by simple acid-base reaction with a hydrophobic group-containing acid such as a fatty acid (especially lauric, oleic, myristic, palmitic, stearic, or 2-ethylhexanoic acid), low-solubility amino acid, benzoic acid, salicylic acid, or an acidic fat-soluble vitamin (such as riboflavin). Other compounds might be obtained by reacting such an acid with another group on the vitamin such as a hydroxyl group to form a linkage such as an ester linkage, etc. Derivatives of a water-soluble vitamin containing an acidic group can be generated in reactions with a hydrophobic group-containing reactant such as stearylamine or riboflavine, for example, to create a compound that is useful in embodiments of the present invention. The linkage of a palmitate chain to vitamin C yields ascorbyl palmitate.

[0182] Amino Acids and Their Salts

[0183] Alanine, arginine, asparagines, aspartic acid, cysteine, cystine, glutamic acid, glutamine, glycine, histidine, proline, isoleucine, leucine, lysine,

methionine, phenylalanine, serine, threonine, tryptophan, tyrosine, valine, and derivatives thereof are other useful additives in embodiments of the invention.

[0184] Certain amino acids, in their zwitterionic form and/or in a salt form with a monovalent or multivalent ion, have polar groups, relatively high octanol-water partition coefficients, and are useful in embodiments of the present invention. In the context of the present disclosure we take "low-solubility amino acid" to mean an amino acid which has a solubility in unbuffered water of less than about 4% (40 mg/ml). These include Cystine, tyrosine, tryptophan, leucine, isoleucine, phenylalanine, asparagine, aspartic acid, glutamic acid, and methionine.

[0185] Amino acid dimers, sugar-conjugates, and other derivatives are also useful. Through simple reactions well known in the art hydrophilic molecules may be joined to hydrophobic amino acids, or hydrophobic molecules to hydrophilic amino acids, to make additional additives useful in embodiments of the present invention.

[0186] Catecholamines, such as dopamine, levodopa, carbidopa, and DOPA, are also useful as additives.

[0187] Oligopeptides, Peptides and Proteins

[0188] Oligopeptides and peptides are useful as additives, since hydrophobic and hydrophilic amino acids may be easily coupled and various sequences of amino acids may be tested to maximally facilitate permeation of tissue by drug.

[0189] Proteins are also useful as additives in embodiments of the present invention. Serum albumin, for example, is a preferred additive since it is water soluble and contains significant hydrophobic parts to bind drug: paclitaxel is 89% to 98% protein-bound after human intravenous infusion, and rapamycin is 92% protein bound, primarily (97%) to albumin. Furthermore, paclitaxel solubility in PBS increases over 20-fold with the addition of BSA. Albumin is naturally present at high concentrations in serum and is thus very safe for human intravascular use.

[0190] Other useful proteins include, without limitation, other albumins, immunoglobulins, caseins, hemoglobins, lysozymes, immunoglobins, a-2-macroglobulin, fibronectins, vitronectins, fibrinogens, lipases, and the like.

[0191] Organic Acids and Their Esters and Anhydrides

[0192] Examples are acetic acid and anhydride, benzoic acid and anhydride, diethylenetriaminepentaacetic acid dianhydride, ethylenediaminetetraacetic

dianhydride, maleic acid and anhydride, succinic acid and anhydride, diglycolic anhydride, glutaric anhydride, ascorbic acid, citric acid, tartaric acid, lactic acid, oxalic acid aspartic acid, nicotinic acid, 2-pyrrolidone-5-carboxylic acid, and 2-pyrrolidone.

[0193] These esters and anhydrides are soluble in organic solvents such as ethanol, acetone, methylethylketone, ethylacetate. The water insoluble drugs can be dissolved in organic solvent with these esters and anhydrides, then coated easily on to the medical device, then hydrolyzed under high pH conditions. The hydrolyzed anhydrides or esters are acids or alcohols, which are water soluble and can effectively carry the drugs off the device into the vessel walls.

[0194] Other chemical compounds with one or more hydroxyl, amine, carbonyl, carboxyl, or ester moieties

[0195] The additives include amino alcohols, alcohols, amines, acids, amides and hydroxyl acids in both cyclo and linear aliphatic and aromatic groups. Examples are L-ascorbic acid and its salt, D-glucoascorbic acid and its salt, tromethamine, triethanolamine, diethanolamine, meglumine, glucamine, amine alcohols, glucoheptonic acid, glucomic acid, hydroxyl ketone, hydroxyl lactone, gluconolactone, glucoheptonolactone, glucooctanoic lactone, gulonic acid lactone, mannoic lactone, ribonic acid lactone, lactobionic acid, glucosamine, glutamic acid, benzyl alcohol, benzoic acid, hydroxybenzoic acid, propyl 4-hydroxybenzoate, lysine acetate salt, gentisic acid, lactobionic acid, lactitol, sorbitol, glucose, ribose, arabinose, lyxose, xylose, fructose, mannose, glucitol, sugars, sugar phosphates, glucopyranose phosphate, sugar sulphates, sinapic acid, vanillic acid, vanillin, methyl paraben, propyl paraben, diethylene glycol, triethylene glycol, tetraethylene glycol, xylitol, 2-ethoxyethanol, sugars, galactose, glucose, mannose, xylose, sucrose, lactose, maltose, sorbitol, cyclodextrin, (2-hydroxypropyl)-cyclodextrin, acetaminophen, ibuprofen, retinoic acid, lysine acetate, gentisic acid, catechin, catechin gallate, tiletamine, ketamine, propofol, lactic acids, acetic acid, salts of any organic acid and amine described above, polyglycidol, glycerols, and derivatives thereof.

[0196] Combinations of additives are also useful for purposes of the present invention.

[0197] One embodiment comprises the combination or mixture of two hydrophilic additives, the first additive comprising a surfactant and the second additive comprising one of the chemical compounds with one or more hydroxyl, amine, carbonyl, carboxyl, or ester moieties

[0198] The combination or mixture of the surfactant and the small water-soluble molecule (the chemical compounds with one or more hydroxyl, amine, carbonyl, carboxyl, or ester moieties) has advantages. Formulations comprising mixtures of the two additives with water-insoluble drug are in certain cases superior to either alone. The hydrophobic drugs bind small molecules more poorly than they do surfactants. They are often phase separated from small water-soluble molecules, which can lead to suboptimal coating uniformity and integrity. The water-insoluble drug has Log P higher than both that of the surfactant and that of small molecules. However, Log P of the surfactant is typically higher than Log P of the chemical compounds with one or more hydroxyl, amine, carbonyl, carboxyl, or ester moieties. The surfactant has a relatively high Log P (usually above 0) and the water soluble molecules have low Log P (usually below 0). Some surfactants, when used as additives in the present invention, adhere so strongly to the water-insoluble drug and the surface of the medical device that drug is not able to rapidly release from the surface of the medical device at the target site. On the other hand, some of the water-soluble small molecules (with one or more hydroxyl, amine, carbonyl, carboxyl, or ester moieties) adhere so poorly to the medical device that they release drug before it reaches the target site, for example, into serum during the transit of a coated balloon catheter to the site targeted for intervention. Surprisingly, by adjusting the ratio of the concentrations of the small hydrophilic molecules, the surfactant, and the contrast agent, the coating stability during transit and rapid drug release when inflated and pressed against tissues of the lumen wall at the target site of therapeutic intervention in certain cases is superior to a formulation comprising either additive or a contrast agent alone. Furthermore, the miscibility and compatibility of the water-insoluble drug and the contrast agent is improved by the presence of the surfactant. The surfactant also improves coating uniformity and integrity by its good adhesion to the drug and to contrast agent and to the small molecules. The long chain hydrophobic part of the surfactant binds drug tightly to

drug while the hydrophilic part of the surfactant binds the contrast agent and also the small molecules.

[0199] The surfactants in the mixture or the combination include all of the surfactants described herein for use in embodiments of the invention. The surfactant in the mixture is chosen from PEG fatty esters, PEG omega-3 fatty esters and alcohols, glycerol fatty esters, sorbitan fatty esters, PEG glyceryl fatty esters, PEG sorbitan fatty esters, sugar fatty esters, PEG sugar esters, Tween 20, Tween 40, Tween 60, Tween 80, p-isononylphenoxypolyglycidol, PEG laurate, PEG oleate, PEG stearate, PEG glyceryl laurate, PEG glyceryl oleate, PEG glyceryl stearate, polyglyceryl laurate, polyglyceryl oleate, polyglyceryl myristate, polyglyceryl palmitate, polyglyceryl-6 laurate, polyglyceryl-6 oleate, polyglyceryl-6 myristate, polyglyceryl-6 palmitate, polyglyceryl-10 laurate, polyglyceryl-10 oleate, polyglyceryl-10 myristate, polyglyceryl-10 palmitate, PEG sorbitan monolaurate, PEG sorbitan monolaurate, PEG sorbitan monooleate, PEG sorbitan stearate, PEG oleyl ether, PEG lauryl ether, octoxynol, monoxynol, tyloxapol, sucrose monopalmitate, sucrose monolaurate, decanoyl-N-methylglucamide, n-decyl - β -D-glucopyranoside, n-decyl - β -D-maltopyranoside, n-dodecyl - β -D-glucopyranoside, n-dodecyl - β -D-maltoside, heptanoyl-N-methylglucamide, n-heptyl - β -D-glucopyranoside, n-heptyl - β -D-thioglucoside, n-hexyl - β -D-glucopyranoside, nonanoyl-N-methylglucamide, n-nonyl - β -D-glucopyranoside, octanoyl-N-methylglucamide, n-octyl - β -D-glucopyranoside, octyl - β -D-thioglucopyranoside and their derivatives.

[0200] The chemical compound with one or more hydroxyl, amine, carbonyl, carboxyl, or ester moieties in the mixture or the combination include all of the chemical compounds with one or more hydroxyl, amine, carbonyl, carboxyl, or ester moieties described for use in embodiments of the invention. The chemical compound with one or more hydroxyl, amine, carbonyl, carboxyl, or ester moieties in the mixture has at least one hydroxyl group in one of the embodiments in the inventions. More than four hydroxyl groups are preferred in one embodiment. The chemical compound with one or more hydroxyl, amine, carbonyl, carboxyl, or ester moieties in the mixture is chosen from L-ascorbic acid and its salt, D-glucoascorbic acid and its salt, tromethamine, triethanolamine, diethanolamine, meglumine,

glucamine, amine alcohols, glucoheptonic acid, glucomic acid, hydroxyl ketone, hydroxyl lactone, gluconolactone, glucoheptonolactone, glucooctanoic lactone, gulonic acid lactone, mannoic lactone, ribonic acid lactone, lactobionic acid, glucosamine, glutamic acid, benzyl alcohol, benzoic acid, hydroxybenzoic acid, propyl 4-hydroxybenzoate, lysine acetate salt, gentisic acid, lactobionic acid, lactitol, sorbitol, glucose, ribose, arabinose, lyxose, xylose, fructose, mannose, glucitol, sugars, sugar phosphates, glucopyranose phosphate, sugar sulphates, sinapic acid, vanillic acid, vanillin, methyl paraben, propyl paraben, diethylene glycol, triethylene glycol, tetraethylene glycol, xylitol, 2-ethoxyethanol, sugars, galactose, glucose, mannose, xylose, sucrose, lactose, maltose, cyclodextrin, sorbitol, (2-hydroxypropyl)-cyclodextrin, acetaminophen, ibuprofen, retinoic acid, lysine acetate, gentisic acid, catechin, catechin gallate, tiletamine, ketamine, propofol, lactic acids, acetic acid, salts of any organic acid and amine described above, polyglycidol, glycerols, and derivatives thereof.

[0201] Preferred additives include p-isononylphenoxypolyglycidol, PEG glyceryl oleate, PEG glyceryl stearate, polyglyceryl laurate, polyglyceryl oleate, polyglyceryl myristate, polyglyceryl palmitate, polyglyceryl-6 laurate, polyglyceryl-6 oleate, polyglyceryl-6 myristate, polyglyceryl-6 palmitate, polyglyceryl-10 laurate, polyglyceryl-10 oleate, polyglyceryl-10 myristate, polyglyceryl-10 palmitate, PEG sorbitan monolaurate, PEG sorbitan monolaurate, PEG sorbitan monooleate, PEG sorbitan stearate, octoxynol, monoxynol, tyloxapol, sucrose monopalmitate, sucrose monolaurate, decanoyl-N-methylglucamide, n-decyl - β -D-glucopyranoside, n-decyl - β -D-maltopyranoside, n-dodecyl - β -D-glucopyranoside, n-dodecyl - β -D-maltoside, heptanoyl-N-methylglucamide, n-heptyl - β -D-glucopyranoside, n-heptyl - β -D-thioglucoside, n-hexyl - β -D-glucopyranoside, nonanoyl-N-methylglucamide, n-nonyl - β -D-glucopyranoside, octanoyl-N-methylglucamide, n-octyl - β -D-glucopyranoside, octyl - β -D-thioglucopyranoside; cystine, tyrosine, tryptophan, leucine, isoleucine, phenylalanine, asparagine, aspartic acid, glutamic acid, and methionine (amino acids); cetotiamine; cycothiamine, dexpanthenol, niacinamide, nicotinic acid and its salt, pyridoxal 5-phosphate, nicotinamide ascorbate, riboflavin, riboflavin phosphate, thiamine, folic acid, menadiol diphosphate, menadione sodium bisulfite, menadoxime, vitamin

B12, vitamin K5, vitamin K6, vitamin K6, and vitamin U (vitamins); albumin, immunoglobulins, caseins, hemoglobins, lysozymes, immunoglobins, a-2-macroglobulin, fibronectins, vitronectins, fibrinogens, lipases, benzalkonium chloride, benzethonium chloride, docecyl trimethyl ammonium bromide, sodium docecylsulfates, dialkyl methylbenzyl ammonium chloride, and dialkylesters of sodium sulfonsuccinic acid, L-ascorbic acid and its salt, D-glucoascorbic acid and its salt, tromethamine, triethanolamine, diethanolamine, meglumine, glucamine, amine alcohols, glucoheptonic acid, glucomic acid, hydroxyl ketone, hydroxyl lactone, gluconolactone, glucoheptonolactone, glucooctanoic lactone, gulonic acid lactone, mannoic lactone, ribonic acid lactone, lactobionic acid, glucosamine, glutamic acid, benzyl alcohol, benzoic acid, hydroxybenzoic acid, propyl 4-hydroxybenzoate, lysine acetate salt, gentisic acid, lactobionic acid, lactitol, sinapic acid, vanillic acid, vanillin, methyl paraben, propyl paraben, sorbitol, cyclodextrin, (2-hydroxypropyl)-cyclodextrin, acetaminophen, ibuprofen, retinoic acid, lysine acetate, gentisic acid, catechin, catechin gallate, tiletamine, ketamine, propofol, lactic acids, acetic acid, salts of any organic acid and amine described above, polyglycidol, glycerols, and derivatives thereof. (chemical compounds with one or more hydroxyl, amino, carbonyl, carboxyl, or ester moieties). Some of these additives are both water-soluble and organic solvent-soluble. They have good adhesive properties and adhere to the surface of polyamide medical devices, such as balloon catheters. They may therefore be used in the adherent layer, top layer, and/or in the drug layer of embodiments of the present invention. The aromatic and aliphatic groups increase the solubility of water insoluble drugs in the coating solution, and the polar groups of alcohols and acids bind contrast agent and improve the physical properties of the coating layer overlying the medical device and accelerate drug release from the device and drug permeation into tissue during deployment.

[0202] Other preferred additives according to embodiments of the invention include the combination of an amino alcohol and an organic acid. Examples are lysine/glutamic acid, lysine acetate, lactobionic acid/meglumine, lactobionic acid/tromethanemine, lactobionic acid/diethanolamine, lactic acid/meglumine, lactic acid/tromethanemine, lactic acid/diethanolamine, gentisic acid/meglumine, gentisic acid/tromethanemine, gentisic acid/diethanolamine, vanillic acid/meglumine, vanillic

acid/tromethanemine, vanillic acid/diethanolamine, benzoic acid/meglumine, benzoic acid/tromethanemine, benzoic acid/diethanolamine, acetic acid/meglumine, acetic acid/tromethanemine, and acetic acid/diethanolamine.

[0203] Other preferred additives according to embodiments of the invention include hydroxyl ketone, hydroxyl lactone, hydroxyl acid, hydroxyl ester, and hydroxyl amide. Examples are gluconolactone, D-glucoheptono-1,4-lactone, glucooctanoic lactone, gulonic acid lactone, mannoic lactone, erythronic acid lactone, ribonic acid lactone, glucuronic acid, gluconic acid, gentisic acid, lactobionic acid, lactic acid, acetaminophen, vanillic acid, sinapic acid, hydroxybenzoic acid, methyl paraben, propyl paraben, and derivatives thereof.

[0204] Other preferred additives that may be useful in embodiments of the present invention include riboflavin, riboflavin-phosphate sodium, Vitamin D3, folic acid (vitamin B9), vitamin 12, diethylenetriaminepentaacetic acid dianhydride, ethylenediaminetetraacetic dianhydride, maleic acid and anhydride, succinic acid and anhydride, diglycolic anhydride, glutaric anhydride, L-ascorbic acid, thiamine, nicotinamide, nicotinic acid, 2-pyrrolidone-5-carboxylic acid, cystine, tyrosine, tryptophan, leucine, isoleucine, phenylalanine, asparagine, aspartic acid, glutamic acid, and methionine and octyl - β -D-thioglucopyranoside.

[0205] From a structural point of view, these additives share structural similarities and are compatible with water insoluble drugs (such as paclitaxel and rapamycin). They often contain double bonds such as C=C, C=N, C=O in aromatic or aliphatic structures. These additives also contain amine, alcohol, ester, amide, anhydride, carboxylic acid, and/or hydroxyl groups. They may form hydrogen bonds and/or charge and/or van der Waals interactions with drug. They may also form hydrogen bonds with and have affinity for contrast agent. They are also useful in the top layer in the coating. Compounds containing one or more hydroxyl, carboxyl, or amine groups, for example, are especially useful as additives since they facilitate drug release from the device surface and easily displace water next to the polar head groups and surface proteins of cell membranes and may thereby remove this barrier to hydrophobic drug permeability. They accelerate movement of a hydrophobic drug off the balloon to the lipid layer of cell membranes and tissues for which it has very high affinity. They may also carry or accelerate the movement of

drug off the balloon into more aqueous environments such as the interstitial space, for example, of vascular tissues that have been injured by balloon angioplasty or stent expansion. Additives such as polyglyceryl fatty esters, ascorbic ester of fatty acids, sugar esters, alcohols and ethers of fatty acids have fatty chains that can integrate into the lipid structure of target tissue membranes, carrying drug to lipid structures. Some of the amino acids, vitamins and organic acids have aromatic C=N groups as well as amino, hydroxyl, and carboxylic components to their structure. They have structural parts that can bind or complex with hydrophobic drug, such as paclitaxel or rapamycin, and they also have structural parts that facilitate tissue penetration by removing barriers between hydrophobic drug and lipid structure of cell membranes.

[0206] For example, isononylphenylpolyglycidol (Olin-10 G and Surfactant-10G), PEG glyceryl monooleate, sorbitan monolaurate (Arlacel 20), sorbitan monopalmitate (Span-40), sorbitan monooleate (Span-80), sorbitan monostearate, polyglyceryl-10 oleate, polyglyceryl-10 laurate, polyglyceryl-10 palmitate, and polyglyceryl-10 stearate all have more than four hydroxyl groups in their hydrophilic part. These hydroxyl groups have very good affinity for the vessel wall and can displace hydrogen-bound water molecules. At the same time, they have long chains of fatty acid, alcohol, ether and ester that can both complex with hydrophobic drug and integrate into the lipid structure of the cell membranes to form the part of the lipid structure. This deformation or loosening of the lipid membrane of target cells may further accelerate permeation of hydrophobic drug into tissue.

[0207] For another example, L-ascorbic acid, thiamine, maleic acids, niacinamide, and 2-pyrrolidone-5-carboxylic acid all have a very high water and ethanol solubility and a low molecular weight and small size. They also have structural components including aromatic C=N, amino, hydroxyl, and carboxylic groups. These structures have very good compatibility with paclitaxel and rapamycin and can increase the solubility of these water-insoluble drugs in water and enhance their absorption into tissues. However, they often have poor adhesion to the surface of medical devices. They are therefore preferably used in combination with other additives in the drug layer and top layer where they are useful to enhance drug absorption. Vitamin D2 and D3 are especially useful

because they themselves have anti-restenotic effects and reduce thrombosis, especially when used in combination with paclitaxel.

[0208] In one embodiment of the present invention, the additive is soluble in aqueous solvents and is soluble in organic solvents.

[0209] Oil, Fatty Acid and Lipid

[0210] In one embodiment, the coating layer overlying the surface of a medical device is comprised of a lipophilic or water-insoluble therapeutic agent, a contrast agent, and one of an oil, a fatty acid, and a lipid. In one embodiment, a solution for coating the surface of a medical device is comprised of a lipophilic or water-insoluble therapeutic agent, a contrast agent, and one of an oil, a fatty acid, and a lipid. In one embodiment, a pharmaceutical preparation is comprised of a lipophilic or water-insoluble therapeutic agent, a contrast agent, and one of an oil, a fatty acid, and a lipid, wherein the therapeutic agent is not encapsulated by liposomes or particles. In one embodiment, the one of an oil, a fatty acid, and a lipid is interdispersed with the lipophilic or water-insoluble drug and the contrast agent in the coating of a medical device. In certain embodiments, the contrast agent may disrupt the hydrophobic attractions between lipophilic drug and itself and the one of an oil, fatty acid, and lipid and the surface of the medical device and accelerate elution of the therapeutic agent off the device.

[0211] In these embodiments, the oil, the fatty acid and the lipid are hydrophobic. They are not soluble in water. The lipophilic or water-insoluble therapeutic agents, such as paclitaxel, rapamycin and their analogues, are soluble in the oil, fatty acid and lipid. The oil, fatty acid and lipid in embodiments of the invention herein include, for example, soybean oil, vegetable oil, flower oil, animal oil, marine oil, butterfat, coconut oil, palm oil, olive oil, peanut oil, fish oil, butanoic acid, hexanoic acid, octanoic acid, decanoic acid, dodecanoic acid, tetradecanoic acid, hexadecanoic acid, octadecanoic acid, octadecatrienoic acid, eicosanoic acid, eicosenoic acid, eicosatetraenoic acid, eicosapentaenoic acid, docosahexaenoic acid, tocotrienol, butyric acid, caproic acid, caprylic acid, capric acid, lauric acid, myristic acid, palmitic acid, palmitoleic acid, stearic acid, oleic acid, vaccenic acid, linoleic acid, alpha-linolenic acid, gamma-linolenic acid, behenic acid, erucic acid, lignoceric acid, natural or synthetic phospholipids, mono-, di-, or triacylglycerols, cardiolipin, phosphatidylglycerol, phosphatidic acid, phosphatidylcholine, alpha

tocopherol, phosphatidylethanolamine, sphingomyelin, phosphatidylserine, phosphatidylinositol, dimyristoylphosphatidylcholine, dioleoylphosphatidylcholine, dipalmitoylphosphatidylcholine, distearoylphosphatidylcholine, phosphatidylethanolamines phosphatidylglycerols, sphingolipids, prostaglandins, gangliosides, neobee, niosomes and derivatives.

[0212] There are many other oils, fatty acids, and lipids known in the art that are useful in embodiments of the present invention.

[0213] In one embodiment, the concentration density of the at least one therapeutic agent applied to the surface of the medical device is from about 1 to 20 $\mu\text{g}/\text{mm}^2$, or more preferably from about 2 to 6 $\mu\text{g}/\text{mm}^2$. In one embodiment, the concentration of the at least one additive applied to the surface of the medical device is from about 1 to 20 $\mu\text{g}/\text{mm}^2$. In one embodiment, the concentration of the contrast agent applied to the surface of the medical device is from about 1 to 20 $\mu\text{g}/\text{mm}^2$. The ratio of additive to drug by weight in the coating layer in embodiments of the present invention is about 0.05 to 20, preferably about 0.5 to 10, or more preferably about 0.8 to 5.

[0214] The relative amount of the therapeutic agent, the contrast agent, and the additive in the coating layer may vary depending on applicable circumstances. The optimal amount of the additive can depend upon, for example, the particular therapeutic agent and contrast agent and additive selected, the critical micelle concentration of the surface modifier, the hydrophilic-lipophilic-balance (HLB) of a surfactant or an additive's the octanol-water partition coefficient (P), the melting point of the additive, the water solubility of the additive and/or therapeutic agent, the surface tension of water solutions of the surface modifier, etc.

[0215] The additives are present in exemplary coating compositions of embodiments of the present invention in amounts such that upon dilution with an aqueous solution, the carrier forms a clear, aqueous dispersion or emulsion or solution, containing the hydrophobic therapeutic agent in aqueous and organic solutions. When the relative amount of surfactant is too great, the resulting dispersion is visibly "cloudy".

[0216] The optical clarity of the aqueous dispersion can be measured using standard quantitative techniques for turbidity assessment. One convenient procedure to measure turbidity is to measure the amount of light of a given

wavelength transmitted by the solution, using, for example, an UV-visible spectrophotometer. Using this measure, optical clarity corresponds to high transmittance, since cloudier solutions will scatter more of the incident radiation, resulting in lower transmittance measurements.

[0217] Another method of determining optical clarity and carrier diffusivity through the aqueous boundary layer is to quantitatively measure the size of the particles of which the dispersion is composed. These measurements can be performed on commercially available particle size analyzers.

[0218] Other considerations will further inform the choice of specific proportions of different additives and contrast agent and drug. These considerations include the degree of bioacceptability of the additives and the desired dosage of hydrophobic therapeutic agent to be provided.

[0219] Therapeutic Agent

[0220] The drugs or biologically active materials, which can be used in embodiments of the present invention, can be any therapeutic agent or substance. The drugs can be of various physical states, e.g., molecular distribution, crystal forms or cluster forms. Examples of drugs that are especially useful in embodiments of the present invention are lipophilic substantially water insoluble drugs, such as paclitaxel, rapamycin, daunorubicin, doxorubicin, lapachone, vitamin D2 and D3 and analogues and derivatives thereof. These drugs are especially suitable for use in a coating on a balloon catheter used to treat tissue of the vasculature.

[0221] Other drugs that may be useful in embodiments of the present invention include, without limitation, glucocorticoids (e.g., dexamethasone, betamethasone), hirudin, angiopeptin, aspirin, growth factors, antisense agents, anti-cancer agents, anti-proliferative agents, oligonucleotides, and, more generally, anti-platelet agents, anti-coagulant agents, anti-mitotic agents, antioxidants, anti-metabolite agents, anti-chemotactic, and anti-inflammatory agents.

[0222] Also useful in embodiments of the present invention are polynucleotides, antisense, RNAi, or siRNA, for example, that inhibit inflammation and/or smooth muscle cell or fibroblast proliferation.

[0223] Anti-platelet agents can include drugs such as aspirin and dipyridamole. Aspirin is classified as an analgesic, antipyretic, anti-inflammatory

and anti-platelet drug. Dipyridamole is a drug similar to aspirin in that it has anti-platelet characteristics. Dipyridamole is also classified as a coronary vasodilator. Anti-coagulant agents for use in embodiments of the present invention can include drugs such as heparin, protamine, hirudin and tick anticoagulant protein. Anti-oxidant agents can include probucol. Anti-proliferative agents can include drugs such as amlodipine and doxazosin. Anti-mitotic agents and anti-metabolite agents that can be used in embodiments of the present invention include drugs such as methotrexate, azathioprine, vincristine, vinblastine, 5-fluorouracil, adriamycin, and mutamycin. Antibiotic agents for use in embodiments of the present invention include penicillin, cefoxitin, oxacillin, tobramycin, and gentamicin. Suitable antioxidants for use in embodiments of the present invention include probucol. Additionally, genes or nucleic acids, or portions thereof can be used as the therapeutic agent in embodiments of the present invention. Furthermore, collagen-synthesis inhibitors, such as tranilast, can be used as a therapeutic agent in embodiments of the present invention.

[0224] Photosensitizing agents for photodynamic or radiation therapy, including various porphyrin compounds such as porfimer, for example, are also useful as drugs in embodiments of the present invention.

[0225] Drugs for use in embodiments of the present invention also include everolimus, somatostatin, tacrolimus, roxithromycin, dunaimycin, ascomycin, bafilomycin, erythromycin, midecamycin, josamycin, concanamycin, clarithromycin, troleandomycin, folimycin, cerivastatin, simvastatin, lovastatin, fluvastatin, rosuvastatin, atorvastatin, pravastatin, pitavastatin, vinblastine, vincristine, vindesine, vinorelbine, etoposide, teniposide, nimustine, carmustine, lomustine, cyclophosphamide, 4-hydroxycyclophosphamide, estramustine, melphalan, ifosfamide, trofosfamide, chlorambucil, bendamustine, dacarbazine, busulfan, procarbazine, treosulfan, temozolomide, thiotepa, daunorubicin, doxorubicin, aclarubicin, epirubicin, mitoxantrone, idarubicin, bleomycin, mitomycin, dactinomycin, methotrexate, fludarabine, fludarabine-5'-dihydrogenphosphate, cladribine, mercaptopurine, thioguanine, cytarabine, fluorouracil, gemcitabine, capecitabine, docetaxel, carboplatin, cisplatin, oxaliplatin, amsacrine, irinotecan, topotecan, hydroxycarbamide, miltefosine, pentostatin, aldesleukin, tretinoin, asparaginase, pegaspargase, anastrozole, exemestane, letrozole, formestane,

aminoglutethimide, adriamycin, azithromycin, spiramycin, cepharantin, smc proliferation inhibitor-2w, epothilone A and B, mitoxantrone, azathioprine, mycophenolatmofetil, c-myc-antisense, b-myc-antisense, betulinic acid, camptothecin, lapachol, beta.-lapachone, podophyllotoxin, betulin, podophyllic acid 2-ethylhydrazide, molgramostim (rhuGM-CSF), peginterferon a-2b, lenograstim (r-HuG-CSF), filgrastim, macrogol, dacarbazine, basiliximab, daclizumab, selectin (cytokine antagonist), CETP inhibitor, cadherines, cytokinin inhibitors, COX-2 inhibitor, NFkB, angiopeptin, ciprofloxacin, camptothecin, fluroblastin, monoclonal antibodies, which inhibit the muscle cell proliferation, bFGF antagonists, probucol, prostaglandins, 1,11-dimethoxycanthin-6-one, 1-hydroxy-11-methoxycanthin-6-one, scopoletin, colchicine, NO donors such as pentaerythritol tetranitrate and syndnoeimines, S-nitrosoderivatives, tamoxifen, staurosporine, beta.-estradiol, a-estradiol, estriol, estrone, ethinylestradiol, fosfestrol, medroxyprogesterone, estradiol cypionates, estradiol benzoates, tranilast, kamebakaurin and other terpenoids, which are applied in the therapy of cancer, verapamil, tyrosine kinase inhibitors (tyrphostines), cyclosporine A, 6-a-hydroxy-paclitaxel, baccatin, taxotere and other macrocyclic oligomers of carbon suboxide (MCS) and derivatives thereof, mofebutazone, acemetacin, diclofenac, lonazolac, dapsone, o-carbamoylphenoxyacetic acid, lidocaine, ketoprofen, mefenamic acid, piroxicam, meloxicam, chloroquine phosphate, penicillamine, hydroxychloroquine, auranofin, sodium aurothiomalate, oxaceprol, celecoxib, .beta.-sitosterin, ademetionine, myrtecaïne, polidocanol, nonivamide, levomenthol, benzocaine, aescin, ellipticine, D-24851 (Calbiochem), colcemid, cytochalasin A-E, indanocine, nocodazole, S 100 protein, bacitracin, vitronectin receptor antagonists, azelastine, guanidyl cyclase stimulator tissue inhibitor of metal proteinase-1 and -2, free nucleic acids, nucleic acids incorporated into virus transmitters, DNA and RNA fragments, plasminogen activator inhibitor-1, plasminogen activator inhibitor-2, antisense oligonucleotides, VEGF inhibitors, IGF-1, active agents from the group of antibiotics such as cefadroxil, cefazolin, cefaclor, cefotaxim, tobramycin, gentamycin, penicillins such as dicloxacillin, oxacillin, sulfonamides, metronidazol, antithrombotics such as argatroban, aspirin, abciximab, synthetic antithrombin, bivalirudin, coumadin, enoxaparin, desulphated and N-reacetylated heparin, tissue plasminogen activator, GpIIb/IIIa platelet membrane receptor, factor Xa inhibitor antibody, heparin, hirudin,

r-hirudin, PPACK, protamin, prourokinase, streptokinase, warfarin, urokinase, vasodilators such as dipyridole, trapidil, nitroprussides, PDGF antagonists such as triazolopyrimidine and seramin, ACE inhibitors such as captopril, cilazapril, lisinopril, enalapril, losartan, thiol protease inhibitors, prostacyclin, vapirost, interferon α , β and γ , histamine antagonists, serotonin blockers, apoptosis inhibitors, apoptosis regulators such as p65 NF- κ B or Bcl-xL antisense oligonucleotides, halofuginone, nifedipine, tranilast, molsidomine, tea polyphenols, epicatechin gallate, epigallocatechin gallate, Boswellic acids and derivatives thereof, leflunomide, anakinra, etanercept, sulfasalazine, etoposide, dicloxacillin, tetracycline, triamcinolone, mutamycin, procainamide, retinoic acid, quinidine, disopyramide, flecainide, propafenone, sotalol, amidorone, natural and synthetically obtained steroids such as bryophyllin A, inotodiol, maquiroside A, ghalakinoside, mansonine, streblolide, hydrocortisone, betamethasone, dexamethasone, non-steroidal substances (NSAIDS) such as fenoprofen, ibuprofen, indomethacin, naproxen, phenylbutazone and other antiviral agents such as acyclovir, ganciclovir and zidovudine, antimycotics such as clotrimazole, flucytosine, griseofulvin, ketoconazole, miconazole, nystatin, terbinafine, antiprozoal agents such as chloroquine, mefloquine, quinine, moreover natural terpenoids such as hippocaesculin, barringtogenol-C21 -angelate, 14-dehydroagrostistachin, agroskerin, agrostistachin, 17-hydroxyagrostistachin, ovatodiols, 4,7-oxycycloanisomelic acid, baccharinoids B1, B2, B3 and B7, tubeimoside, bruceanol A, B and C, bruceantinoside C, yadanziosides N and P, isodeoxyelephantopin, tomenphantopin A and B, coronarin A, B, C and D, ursolic acid, hyptatic acid A, zeorin, iso-iridogermanal, maytenfoliol, effusantin A, excisanin A and B, longikaurin B, sculponeatin C, kamebaunin, leukamenin A and B, 13,18-dehydro-6- α -seneciolyloxychaparrin, taxamairin A and B, regenilol, triptolide, moreover cymar, apocymarin, aristolochic acid, anopterin, hydroxyanopterin, anemonin, protoanemonin, berberine, cheliburin chloride, cictoxin, sinococuline, bombrestatin A and B, cudraisoflavone A, curcumin, dihydronitidine, nitidine chloride, 12- β -hydroxypregnadien-3,20-dione, bilobol, ginkgol, ginkgolic acid, helenalin, indicine, indicine-N-oxide, lasiocarpine, inotodiol, glycoside 1a, podophyllotoxin, justicidin A and B, larreatin, malloterin, mallotochromanol, isobutyrylmallotochromanol, maquiroside A, marchantin A, maytansine, lycoridicin, margetine, pancratistatin,

liriodenine, bisparthenolidine, oxoushinsunine, aristolactam-All, bisparthenolidine, periplocoside A, ghalakinoside, ursolic acid, deoxyypsorospermin, psychorubin, ricin A, sanguinarine, manwu wheat acid, methylsorbifolin, sphatheliachromen, stizophyllin, mansonine, strebloside, akagerine, dihydrousambarensine, hydroxyusambarine, strychnopentamine, strychnophylline, usambarine, usambarensine, berberine, liriodenine, oxoushinsunine, daphnoretin, lariciresinol, methoxylariciresinol, syringaresinol, umbelliferon, afromoson, acetylvismione B, desacetylvismione A, and vismione A and B.

[0226] A combination of drugs can also be used in embodiments of the present invention. Some of the combinations have additive effects because they have a different mechanism, such as paclitaxel and rapamycin, paclitaxel and active vitamin D, paclitaxel and lapachone, rapamycin and active vitamin D, rapamycin and lapachone. Because of the additive effects, the dose of the drug can be reduced as well. These combinations may reduce complications from using a high dose of the drug.

[0227] Adherent Layer

[0228] The adherent layer, which is an optional layer underlying the drug coating layer, improves the adherence of the drug coating layer to the exterior surface of the medical device and protects coating integrity. If drug, contrast agent, and additive differ in their adherence to the medical device, the adherent layer may prevent differential loss (during transit) or elution (at the target site) of drug layer components in order to maintain consistent drug-to-additive or drug-to-drug or drug-to-contrast agent ratio in the drug layer and therapeutic delivery at the target site of intervention. Furthermore, the adherent layer may function to facilitate release of coating layer components which otherwise might adhere too strongly to the device for elution during brief contact with tissues at the target site. For example, in the case where a particular drug binds the medical device tightly, more hydrophilic components are incorporated into the adherent layer in order to decrease affinity of the drug to the device surface.

[0229] The adherent layer may also comprise one or more of the additives previously described, contrast agent, or other components, in order to maintain the integrity and adherence of the coating layer to the device and to facilitate both

adherence of drug, contrast agent, and additive components during transit and rapid elution during deployment at the site of therapeutic intervention.

[0230] Top Layer

[0231] In order to further protect the integrity of the drug layer, an optional top layer may be applied to prevent loss of drug during transit through tortuous anatomy to the target site or during the initial expansion of the device before the coating makes direct contact with target tissue. The top layer may release slowly in the body lumen while protecting the drug layer. The top layer will erode more slowly if it is comprised of more hydrophobic, high molecular weight additives. Surfactants are examples of more hydrophobic structures with long fatty chains, such as Tween 20, Tween 40, Tween 60, Tween 80, and polyglyceryl oleate. High molecular weight additives include polyethylene oxide, polyethylene glycol, and polyvinyl pyrrolidone. Hydrophobic drug itself can act as a top layer component. For example, paclitaxel or rapamycin are hydrophobic. They can be used in the top layer. On the other hand, the top layer cannot erode too slowly or it might actually slow the release of drug during deployment at the target site. Other additives useful in the top coat include additives that strongly interact with drug or with the coating layer, such as L-ascorbic acid and its salt, D-glucoascorbic acid and its salt, tromethamine, triethanolamine, diethanolamine, meglumine, glucamine, amine alcohols, glucoheptonic acid, gluconic acid, gluconolactone, glucosamine, glutamic acid, benzyl alcohol, benzoic acid, hydroxybenzoic acid, propyl 4-hydroxybenzoate, lysine acetate salt, gentisic acid, lactobionic acid, lactitol, sinapic acid, vanillic acid, vanillin, methyl paraben, propyl paraben, cyclodextrin, (2-hydroxypropyl)-cyclodextrin, acetaminophen, ibuprofen, retinoic acid, lysine acetate, gentisic acid, catechin, catechin gallate, tiletamine, ketamine, propofol, lactic acids, acetic acid, salts of any organic acid and amine described above, polyglycidol, glycerols, multiglycerols, and derivatives thereof.

[0232] Solvents

[0233] Solvents for preparing of the coating layer may include, as examples, any combination of one or more of the following: (a) water, (b) alkanes such as hexane, octane, cyclohexane, and heptane, (c) aromatic solvents such as benzene, toluene, and xylene, (d) alcohols such as ethanol, propanol, and isopropanol, diethylamide, ethylene glycol monoethyl ether, Trascutol, and benzyl alcohol (e)

ethers such as dioxane, dimethyl ether and tetrahydrofuran, (f) esters/acetates such as ethyl acetate and isobutyl acetate, (g) ketones such as acetone, acetonitrile, diethyl ketone, and methyl ethyl ketone, and (h) mixture of water and organic solvents such as water/ethanol, water/acetone, water/methanol, water/tetrahydrofuran.

[0234] Organic solvents, such as short-chained alcohol, dioxane, tetrahydrofuran, dimethylformamide, acetonitrile, dimethylsulfoxide, etc., are particularly useful and preferred solvents in embodiments of the present invention because these organic solvents generally disrupt colloidal aggregates and co-solubilize all the components in the coating solution.

[0235] The therapeutic agent, contrast agent, and additive or additives may be dispersed in, solubilized, or otherwise mixed in the solvent. The weight percent of drug and contrast agent and additives in the solvent may be in the range of 0.1-80% by weight, preferably 2-20% by weight.

[0236] Another embodiment of the invention relates to a method for preparing a medical device, particularly, for example, a balloon catheter or a stent. First, a coating solution or suspension comprising at least one solvent, at least one therapeutic agent, at least one contrast agent, and at least one additive is prepared. In at least one embodiment, the coating solution or suspension includes only these four components. The content of the therapeutic agent in the coating solution can be from 0.5-50% by weight based on the total weight of the solution. The content of the contrast agent or of the additive in the coating solution can be from 1-45% by weight, 1 to 40% by weight, or from 1-15% by weight based on the total weight of the solution. The amount of solvent used depends on the coating process and viscosity. It will affect the uniformity of the drug-additive/contrast agent coating but will be evaporated.

[0237] In other embodiments, two or more solvents, two or more therapeutic agents, and/or two or more contrast agents, and/or two or more additives may be used in the coating solution.

[0238] Various techniques may be used for applying a coating solution to a medical device such as casting, spinning, spraying, dipping (immersing), ink jet printing, electrostatic techniques, and combinations of these processes. Choosing an application technique principally depends on the viscosity and surface tension of

the solution. In embodiments of the present invention, dipping and spraying are preferred because it makes it easier to control the uniformity of the thickness of the coating layer as well as the concentration of the therapeutic agent applied to the medical device. Regardless of whether the coating is applied by spraying or by dipping or by another method or combination of methods, each layer is usually deposited on the medical device in multiple application steps in order to control the uniformity and the amount of therapeutic substance and additive applied to the medical device.

[0239] Each applied layer is from about 0.1 microns to 15 microns in thickness. The total number of layers applied to the medical device is in a range of from about 2 to 50. The total thickness of the coating is from about 2 to 200 microns.

[0240] As discussed above, spraying and dipping are particularly useful coating techniques for use in embodiments of the present invention. In a spraying technique, a coating solution or suspension of an embodiment of the present invention is prepared and then transferred to an application device for applying the coating solution or suspension to a balloon catheter.

[0241] An application device that may be used is a paint jar attached to an air brush, such as a Badger Model 150, supplied with a source of pressurized air through a regulator (Norgren, 0-160 psi). When using such an application device, once the brush hose is attached to the source of compressed air downstream of the regulator, the air is applied. The pressure is adjusted to approximately 15-25 psi and the nozzle condition checked by depressing the trigger.

[0242] Prior to spraying, both ends of the relaxed balloon are fastened to the fixture by two resilient retainers, i.e., alligator clips, and the distance between the clips is adjusted so that the balloon remained in a deflated, folded, or an inflated or partially inflated, unfolded condition. The rotor is then energized and the spin speed adjusted to the desired coating speed, about 40 rpm.

[0243] With the balloon rotating in a substantially horizontal plane, the spray nozzle is adjusted so that the distance from the nozzle to the balloon is about 1-4 inches. First, the coating solution is sprayed substantially horizontally with the brush being directed along the balloon from the distal end of the balloon to the proximal end and then from the proximal end to the distal end in a sweeping motion

at a speed such that one spray cycle occurred in about three balloon rotations. The balloon is repeatedly sprayed with the coating solution, followed by drying, until an effective amount of the drug is deposited on the balloon.

[0244] In one embodiment of the present invention, the balloon is inflated or partially inflated, the coating solution is applied to the inflated balloon, for example by spraying, and then the balloon is deflated and folded before drying. Drying may be performed under vacuum.

[0245] It should be understood that this description of an application device, fixture, and spraying technique is exemplary only. Any other suitable spraying or other technique may be used for coating the medical device, particularly for coating the balloon of a balloon catheter or stent delivery system or stent.

[0246] After the medical device is sprayed with the coating solution, the coated balloon is subjected to a drying in which the solvent in the coating solution is evaporated. This produces a coating matrix on the balloon containing the therapeutic agent. One example of a drying technique is placing a coated balloon into an oven at approximately 20°C or higher for approximately 24 hours. Any other suitable method of drying the coating solution may be used. The time and temperature may vary with particular additives and therapeutic agents.

[0247] Optional Post Treatment

[0248] After depositing the drug-additive containing layer on the device of certain embodiments of the present invention, dimethyl sulfoxide (DMSO) or other solvent may be applied, by dip or spray or other method, to the finished surface of the coating. DMSO readily dissolves drugs and easily penetrates membranes and may enhance tissue absorption.

[0249] It is contemplated that the medical devices of embodiments of the present invention have applicability for treating blockages and occlusions of any body passageways, including, among others, the vasculature, including coronary, peripheral, and cerebral vasculature, the gastrointestinal tract, including the esophagus, stomach, small intestine, and colon, the pulmonary airways, including the trachea, bronchi, bronchioles, the sinus, the biliary tract, the urinary tract, prostate and brain passages. They are especially suited for treating tissue of the vasculature with, for example, a balloon catheter or a stent.

[0250] Yet another embodiment of the present invention relates to a method of treating a blood vessel. The method includes inserting a medical device comprising a coating into a blood vessel. The coating layer comprises a therapeutic agent, a contrast agent, and an additive. In this embodiment, the medical device can be configured as having at least an expandable portion. Some examples of such devices include balloon catheters, perfusion balloon catheters, cutting balloon catheters, scoring balloon catheters, self-expanded and balloon expanded-stents, guide catheters, guide wires, embolic protection devices, and various imaging devices.

[0251] As mentioned above, one example of a medical device that is particularly useful in the present invention is a coated balloon catheter. A balloon catheter typically has a long, narrow, hollow tube tabbed with a miniature, deflated balloon. In embodiments of the present invention, the balloon is coated with a drug solution. Then, the balloon is maneuvered through the cardiovascular system to the site of a blockage, occlusion, or other tissue requiring a therapeutic agent. Once in the proper position, the balloon is inflated and contacts the walls of the blood vessel and/or a blockage or occlusion. It is an object of embodiments of the present invention to rapidly deliver drug to and facilitate absorption by target tissue. It is advantageous to efficiently deliver drug to tissue in as brief a period of time as possible while the device is deployed at the target site. The therapeutic agent is released into such tissue, for example the vessel walls, in about 0.1 to 30 minutes, for example, or preferably about 0.1 to 10 minutes, or more preferably about 0.2 to 2 minutes, or most preferably, about 0.1 to 1 minutes, of balloon inflation time pressing the drug coating into contact with diseased vascular tissue.

[0252] Further, the balloon catheter may be used to treat vascular tissue/disease alone or in combination with other methods for treating the vasculature, for example, photodynamic therapy or atherectomy. Atherectomy is a procedure to remove plaque from arteries. Specifically, atherectomy removes plaque from peripheral and coronary arteries. The medical device used for peripheral or coronary atherectomy may be a laser catheter or a rotator or a direct atherectomy device on the end of a catheter. The catheter is inserted into the body and advanced through an artery to the area of narrowing. After the atherectomy has removed some of the plaque, balloon angioplasty using the

coated balloon of embodiments of the present invention may be performed. In addition, stenting may be performed thereafter, or simultaneous with expansion of the coated balloon as described above. Photodynamic therapy is a procedure where light or irradiated energy is used to kill target cells in a patient. A light-activated photosensitizing drug may be delivered to specific areas of tissue by embodiments of the present invention. A targeted light or radiation source selectively activates the drug to produce a cytotoxic response and mediate a therapeutic anti-proliferative effect.

[0253] In some of the embodiments of drug and contrast agent-containing coatings and layers according to the present invention, however, the coating or layer does not include polymers, oils, or lipids. And, furthermore, the therapeutic agent is not encapsulated in polymer particles, micelles, or liposomes. As described above, such formulations have significant disadvantages and can inhibit the intended efficient, rapid release and tissue penetration of the agent, especially in the environment of diseased tissue of the vasculature.

[0254] Although various embodiments are specifically illustrated and described herein, it will be appreciated that modifications and variations of the present invention are covered by the above teachings and are within the purview of the appended claims without departing from the spirit and intended scope of the invention.

[0255] Unless otherwise indicated, all numbers expressing quantities of components in a layer, reaction conditions, and so forth used in the specification and claims are to be understood as being modified in all instances by the term "about." Accordingly, unless otherwise indicated to the contrary, the numerical parameters set forth in this specification and attached claims are approximations that may vary depending upon the desired properties sought to be obtained by the present disclosure.

[0256] Preparation

The medical device and the coating layers of embodiments of the present invention can be made according to various methods. For example, the coating solution can be prepared by dispersing, dissolving, diffusing, or otherwise mixing all the ingredients, such as a therapeutic agent, a contrast agent, an additive, and a solvent, simultaneously together. Also, the coating solution can be prepared by

sequentially adding each component based on solubility or any other parameters. For example, the coating solution can be prepared by first adding the therapeutic agent to the solvent and then adding the additive and the contrast agent. Alternatively, the additive and the contrast agent can be added to the solvent first and then the therapeutic agent can be later added. If the solvent used does not sufficiently dissolve the drug, it is preferable to first add the additive to the solvent, then the drug, since the additive will increase drug solubility in the solvent.

[0257] **EXAMPLES**

[0258] The following examples include embodiments of medical devices and coating layers within the scope of the present invention. While the following examples are considered to embody the present invention, the examples should not be interpreted as limitations upon the present invention.

[0259] Example 1.

[0260] Preparation of coating solutions:

[0261] **Formulation 1**-50-100 mg (0.06-0.12 mmole) paclitaxel, 1-1.6 ml acetone, 1-1.6 ml ethanol, 50-100 mg iopromide, and 50-100 mg Tween 20 are mixed.

[0262] **Formulation 2**-50-100 mg (0.06-0.12 mmole) paclitaxel, 1-1.6 ml acetone, 1-1.6 ml ethanol, 50-100 mg iopromide, and 50-100 mg Tween 40 are mixed.

[0263] **Formulation 3**-50-100 mg (0.05-0.11 mmole) rapamycin, 1-1.6 ml acetone, 1-1.6 ml ethanol, 50-100 mg iopromide, and 50-100 mg Tween 20 are mixed.

[0264] **Formulation 4**-50-100 mg (0.05-0.11 mmole) rapamycin, 0.5-1.0 ml acetone, 0.5-1.0 ml ethanol, 5-35 mg iopromide, and 35-70 mg Tween 40 are mixed.

[0265] **Formulation 5**-50-100 mg (0.06-0.12 mmole) paclitaxel, 1-1.6 ml acetone, 1-1.6 ml ethanol, 50-100 mg loversol, and 50-100 mg Tween 20 are mixed.

[0266] **Formulation 6**-50-100 mg (0.06-0.12 mmole) paclitaxel, 1-1.6 ml acetone, 1-1.6 ml ethanol, 50-100 mg loxerol, and 50-100 mg Tween 40 are mixed.

[0267] **Formulation 7**-50-100 mg (0.05-0.11 mmole) rapamycin, 1-1.6 ml acetone, 1-1.6 ml ethanol, 50-100 mg iomeprol, and 50-100 mg Tween 20 are mixed.

[0268] **Formulation 8**-50-100 mg (0.05-0.11 mmole) rapamycin, 0.5-1.0 ml acetone, 0.5-1.0 ml ethanol, 5-35 mg iomeprol, and 35-70 mg Tween 40 are mixed.

[0269] Example 2

[0270] 5 PTCA balloon catheters (3 mm in diameter and 20 mm in length) are folded with three wings under vacuum. The folded balloon under vacuum is sprayed or dipped in a formulation (1-8) in example 1. The folded balloon is then dried, sprayed or dipped again, dried again, and sprayed or dipped again until sufficient amount of drug on the balloon (3 microgram per square mm) is obtained. The coated folded balloon is then rewrapped and sterilized for animal testing.

[0271] Example 3

[0272] Drug coated balloon catheters and uncoated balloon catheters (as control) are inserted into coronary arteries in pigs. The balloon is over dilated (1:1.2), and the inflated balloon is held in the vessel for 60 seconds to release drug and additive, then deflated and withdrawn from the pig. The animals are angiographed after 3 days, 31 days, 3 months, 6 months, 9 months and 12 months. The amount of drug in the artery tissues of the sacrificed animal is measured after 60 minutes, 3 days, 31 days, 3 months, 6 months, 9 months and 12 months.

[0273] Example 4

[0274] 5 coronary stents (3 mm in diameter and 18 mm in length) are spray or dip coated with the formulation (1-8) in example 1. The stents are then dried, sprayed or dipped again, and dried again until a sufficient amount of drug on the stent (3 microgram per square mm) is obtained. The coated stent is then crimped on PTCA balloon catheters (3 mm in diameters and 20 mm in length). The coated stents with balloon catheters are then sterilized for animal testing.

[0275] Example 5

[0276] The drug coated stent and uncoated stent (as control) are inserted into coronary arteries in pigs, then the balloon is over dilated (1:1.2). The stent is implanted and drug and additive is released, and the balloon is deflated and withdrawn from the pig. The animals are then angiographed after 5, 30, 60 minutes, 3 days, 31 days, 3 months, 6 months, 9 months and 12 months. The amount of drug in the artery tissues of the sacrificed animal is measured 60 minutes, 1 day, 3 days, 31 days, 3 months, 6 months, 9 months and 12 months.

[0277] Example 6

[0278] 5 PTCA balloon catheters are sprayed or dipped in the formulation (1-8) in example 1, dried, and sprayed or dipped and dried again until sufficient amount of drug on balloon is obtained (3 microgram per square mm). A bare metal coronary stent (3 mm in diameter and 20 mm in length) is crimped on each coated balloon. The coated balloons with crimped bare metal stents are then wrapped and sterilized for animal test.

[0279] Example 7

[0280] The drug coated balloon with expandable bare metal stent of Examples 6 and plain balloon with expandable bare metal stent (as control) are inserted into coronary arteries in pigs, and the balloon is over dilated (1:1.2). Stent is implanted, and the balloon is held inflated for 60 seconds to release drug and additive, and the balloon is deflated and withdrawn from the pig. The animals are then angiographed after 5, 30, 60 minutes, 3 days, 31 days, 3 months, 6 months, 9 months and 12 months. The amount of drug in the artery tissues of the sacrificed animal is measured after 60 minutes, 1 day, 3 days, 31 days, 3 months, 6 months, 9 months and 12 months.

[0281] Example 8

[0282] The drug coated balloon catheters and uncoated balloon catheters (as control) are inserted via a bronchoscope into the pulmonary airway in pigs. The balloon is dilated, and the inflated balloon is held expanded in the lumen for 60

seconds to release drug and additive. The balloon is deflated and withdrawn from the pig. The animals are then examined bronchoscopically and tissues samples are taken for pathology and quantification of drug uptake after 3 days, 31 days, 3 months, 6 months, 9 months and 12 months.

[0283] Example 9

[0284] The uncoated stent delivery catheters are inserted into the vascular lumen in pigs. The balloon is dilated, the stent is deployed, and the deflated balloon is then withdrawn. The pharmaceutical formulation (1-8) of example 1 (10 -100 ml) is injected (about 5-15 mg drug per pig) at the site of stent implantation. The drug is then absorbed by injured tissue. The animals are then examined and tissues samples were taken for pathology.

[0285] Example 10

[0286] The diseased tissue (breast cancer or prostate or atheroma or stenosis) is removed surgically from a human body. The pharmaceutical formulation (1-8) of example 1 (10-100 ml) is then injected into or onto the surgical cavities created by the surgical intervention (about 5 – 20 mg drug). The local drug delivery included injection by long needle, guide catheters, introducer sheath, drug infusion tube and other drug delivery catheters. The drug is then absorbed by tissue at the target site.

[0287] Example 11

[0288] 6 PTCA balloon catheters (3.5 and 3.0 mm in diameter and 20 mm in length) are inflated at 1-3 atm. The inflated balloon is loaded with a formulation (1-8) in example 1. A sufficient amount of drug on the balloon (3 microgram per square mm) is obtained. The inflated balloon is folded, and then dried. The coated folded balloon is then rewrapped and sterilized for animal testing.

[0289] The coated PTCA balloon catheter is inserted into a target site in the coronary vasculature (LAD, LCX and RCA) of a 25-45 pound pig. The balloon is inflated to about 12 atm. The overstretch ratio (the ratio of balloon diameter to vessel diameter) is about 1.15 -1.20. The drug is delivered into the blood vessel during 30-60 seconds of inflation. The balloon catheter is then deflated and is

withdrawn from animal body. The target blood vessel is harvested 0.25 -24 hours after the procedure. The drug content in the target tissue and the residual drug remaining on the balloon is analyzed by tissue extraction and HPLC.

[0290] In some of these animal studies, a stent is crimped on the drug coated balloon catheters prior to deployment. In chronic animal tests, angiography is performed before and after all interventions and at 28-35 days after the procedure. Luminal diameters are measured and late lumen loss is calculated. Late lumen loss is the difference between the minimal lumen diameter measured after a period of follow-up time (usually weeks to months after an intervention, such as angioplasty and stent placement in the case of this example) and the minimal lumen diameter measured immediately after the intervention. Restenosis may be quantified by the diameter stenosis, which is the difference between the mean lumen diameters at follow-up and immediately after the procedure divided by the mean lumen diameter immediately after the procedure.

[0291] Example 12

[0292] 6 PTCA balloon components (3.5 and 3.0 mm in diameter and 20 mm in length) are loaded with formulation 1 provided in Example 1. A sufficient amount of drug ($3 \mu\text{g}/\text{mm}^2$) is obtained on the balloon surface. The balloon is dried.

[0293] A formulation for a top coating layer is then prepared. The formulation of the top coating layer is paclitaxel, and one additive chosen from Tween 20, Tween 80, polypropylene glycol-425 (PPG-425), and polypropyl glycol-1000 (PPG-1000), in acetone. The balloon surface of the control catheters is only loaded with formulation 1. 25-50 mg of the top coating formulation (about 50% of paclitaxel by weight) in acetone is coated over the formulation 1 coating layer on the other balloon surfaces. The coated balloons are dried for drug releasing testing in vitro.

[0294] The releasing experiment is designed to test how much drug is lost during balloon inflation. Each of the coated balloons is inflated to 12 atm. in 1% BSA solution at 37°C for 2 minutes. The drug, additive and top coating are released. The residual drug on the balloon catheters is analyzed by HPLC. The top

coating layer reduces drug loss in the tests in vitro during inflation of the balloon components.

WHAT IS CLAIMED IS:

1. A medical device for delivering a therapeutic agent to a tissue, the device comprising a layer overlying an exterior surface of the medical device, the layer comprising a therapeutic agent, a contrast agent, and an additive, wherein the additive comprises a hydrophilic part and a drug affinity part, wherein the drug affinity part is at least one of a hydrophobic part, a part that has an affinity to the therapeutic agent by hydrogen bonding, and a part that has an affinity to the therapeutic agent by van der Waals interactions, wherein the additive is water-soluble, wherein the additive is at least one of a surfactant and a chemical compound.
2. The medical device according to claim 1, wherein the contrast agent is chosen from iobitridol, iohexol, iomeprol, iopamidol, iopentol, iopromide, ioversol, ioxilan, iotrolan, iodixanol, ioxaglate, and their derivatives.
3. The medical device according to claim 1, wherein the chemical compound is chosen from amino alcohols, hydroxyl carboxylic acid, ester, anhydrides, hydroxyl ketone, hydroxyl lactone, hydroxyl ester, sugar phosphate, sugar sulfate, ethyl oxide, ethyl glycols, amino acids, peptides, proteins, sorbitan, glycerol, polyalcohol, phosphates, sulfates, organic acids, esters, salts, vitamins, combinations of amino alcohol and organic acid, and their substituted molecules.
4. The medical device according to claim 1, wherein the surfactant is chosen from ionic, nonionic, aliphatic, and aromatic surfactants, PEG fatty esters, PEG omega-3 fatty esters, ether, and alcohols, glycerol fatty esters, sorbitan fatty esters, PEG glyceryl fatty esters, PEG sorbitan fatty esters, sugar fatty esters, PEG sugar esters, and derivatives thereof.
5. The medical device according to claim 1, wherein the chemical compound has one or more hydroxyl, amino, carbonyl, carboxyl, acid, amide or ester groups.

6. The medical device according to claim 5, wherein the chemical compound having one or more hydroxyl, amino, carbonyl, carboxyl, acid, amide or ester groups is chosen from amino alcohols, hydroxyl carboxylic acid, ester, anhydrides, hydroxyl ketone, hydroxyl lactone, hydroxyl ester, sugar phosphate, sugar sulfate, ethyl oxide, ethyl glycols, amino acids, peptides, proteins, sorbitan, glycerol, polyalcohol, phosphates, sulfates, organic acids, esters, salts, vitamins, combinations of amino alcohol and organic acid, and their substituted molecules.

7. A medical device for delivering a therapeutic agent to a tissue, the device comprising a layer overlying an exterior surface of the medical device, the layer comprising a therapeutic agent, a contrast agent, and an additive, wherein the additive comprises a hydrophilic part and a drug affinity part, wherein the drug affinity part is at least one of a hydrophobic part, a part that has an affinity to the therapeutic agent by hydrogen bonding, and a part that has an affinity to the therapeutic agent by van der Waals interactions, and wherein the additive is chosen from p-isononylphenoxypolyglycidol, PEG laurate, Tween 20, Tween 40, Tween 60, PEG oleate, PEG stearate, PEG glyceryl laurate, PEG glyceryl oleate, PEG glyceryl stearate, polyglyceryl laurate, polyglyceryl oleate, polyglyceryl myristate, polyglyceryl palmitate, polyglyceryl-6 laurate, polyglyceryl-6 oleate, polyglyceryl-6 myristate, polyglyceryl-6 palmitate, polyglyceryl-10 laurate, polyglyceryl-10 oleate, polyglyceryl-10 myristate, polyglyceryl-10 palmitate PEG sorbitan monolaurate, PEG sorbitan monooleate, PEG sorbitan stearate, PEG oleyl ether, PEG laurayl ether, octoxynol, monoxynol, tyloxapol, sucrose monopalmitate, sucrose monolaurate, decanoyl-N-methylglucamide, n-decyl - β -D-glucopyranoside, n-decyl - β -D-maltopyranoside, n-dodecyl - β -D-glucopyranoside, n-dodecyl - β -D-maltoside, heptanoyl-N-methylglucamide, n-heptyl- β -D-glucopyranoside, n-heptyl - β -D-thioglucoside, n-hexyl - β -D-glucopyranoside, nonanoyl-N-methylglucamide, n-nonyl - β -D-glucopyranoside, octanoyl-N-methylglucamide, n-octyl- β -D-glucopyranoside, octyl - β -D-thioglucopyranoside; cystine, tyrosine, tryptophan, leucine, isoleucine, phenylalanine, asparagine, aspartic acid, glutamic acid, and methionine; acetic anhydride, benzoic anhydride, ascorbic acid, 2-pyrrolidone-5-carboxylic acid,

sodium pyrrolidone carboxylate, ethylenediaminetetraacetic dianhydride, maleic and anhydride, succinic anhydride, diglycolic anhydride, glutaric anhydride, acetiamine, benfotiamine, pantothenic acid; cetotiamine; cycothiamine, dexpanthenol, niacinamide, nicotinic acid, pyridoxal 5-phosphate, nicotinamide ascorbate, riboflavin, riboflavin phosphate, thiamine, folic acid, menadiol diphosphate, menadione sodium bisulfite, menadoxime, vitamin B12, vitamin K5, vitamin K6, vitamin K6, and vitamin U; albumin, immunoglobulins, caseins, hemoglobins, lysozymes, immunoglobins, a-2-macroglobulin, fibronectins, vitronectins, firbinogens, lipases, benzalkonium chloride, benzethonium chloride, docecyl trimethyl ammonium bromide, sodium docecylsulfates, dialkyl methylbenzyl ammonium chloride, and dialkylesters of sodium sulfonsuccinic acid, L-ascorbic acid and its salt, D-glucoascorbic acid and its salt, tromethamine, triethanolamine, diethanolamine, meglumine, glucamine, amine alcohols, glucoheptonic acid, glucomic acid, hydroxyl ketone, hydroxyl lactone, gluconolactone, glucoheptonolactone, glucooctanoic lactone, gulonic acid lactone, mannoic lactone, ribonic acid lactone, lactobionic acid, glucosamine, glutamic acid, benzyl alcohol, benzoic acid, hydroxybenzoic acid, propyl 4-hydroxybenzoate, lysine acetate salt, gentisic acid, lactobionic acid, lactitol, sinapic acid, vanillic acid, vanillin, methyl paraben, propyl paraben, sorbitol, xylitol, cyclodextrin, (2-hydroxypropyl)-cyclodextrin, acetaminophen, ibuprofen, retinoic acid, lysine acetate, gentisic acid, catechin, catechin gallate, tiletamine, ketamine, propofol, lactic acids, acetic acid, salts of any organic acid and organic amine, polyglycidol, glycerol, multiglycerols, galactitol, di(ethylene glycol), tri(ethylene glycol), tetra(ethylene glycol), penta(ethylene glycol), poly(ethylene glycol) oligomers, di(propylene glycol), tri(propylene glycol), tetra(propylene glycol, and penta(propylene glycol), poly(propylene glycol) oligomers, a block copolymer of polyethylene glycol and polypropylene glycol, and derivatives and combinations thereof.

8. The medical device according to claim 1, wherein the tissue includes tissue of one of coronary vasculature, peripheral vasculature, cerebral vasculature, esophagus, airways, sinus, trachea, colon, biliary tract, urinary tract, prostate, and brain passages.

9. The medical device according to claim 1, wherein the device includes one of a balloon catheter, a perfusion balloon catheter, an infusion catheter, a cutting balloon catheter, a scoring balloon catheter, a laser catheter, an atherectomy device, a debulking catheter, a stent, a filter, a stent graft, a covered stent, a patch, a wire, and a valve.
10. The medical device according to claim 1, wherein the therapeutic agent is one of paclitaxel and analogues thereof, rapamycin and analogues thereof, beta-lapachone and analogues thereof, biological vitamin D and analogues thereof, and a mixture of these therapeutic agents.
11. The medical device according to claim 1, wherein the therapeutic agent is in combination with a second therapeutic agent, wherein the therapeutic agent is one of paclitaxel, rapamycin, and analogues thereof, and wherein the second therapeutic agent is one of beta-lapachone, biological active vitamin D, and their analogues.
12. The medical device according to claim 1, wherein the device further comprises an adherent layer between the exterior surface of the medical device and the layer.
13. The medical device according to claim 1, wherein the device further comprises a top layer overlying the surface of the layer overlying the exterior surface of the medical device to reduce loss of drug during transit through a body to the tissue.
14. The medical device according to claim 13, wherein the top layer comprises an additive that is less hydrophilic than the additive in the layer overlying the exterior surface of the medical device, and wherein the additive of the top layer is chosen from p-isononylphenoxypolyglycidol, PEG laurate, Tween 20, Tween 40, Tween 60, PEG oleate, PEG stearate, PEG glyceryl laurate, PEG glyceryl oleate, PEG glyceryl stearate, polyglyceryl laurate, polyglyceryl oleate, polyglyceryl myristate, polyglyceryl palmitate, polyglyceryl-6 laurate, polyglyceryl-6 oleate,

polyglyceryl-6 myristate, polyglyceryl-6 palmitate, polyglyceryl-10 laurate, polyglyceryl-10 oleate, polyglyceryl-10 myristate, polyglyceryl-10 palmitate PEG sorbitan monolaurate, PEG sorbitan monolaurate, PEG sorbitan monooleate, PEG sorbitan stearate, PEG oleyl ether, PEG lauryl ether, octoxynol, monoxynol, tyloxapol, sucrose monopalmitate, sucrose monolaurate, decanoyl-N-methylglucamide, n-decyl - β -D-glucopyranoside, n-decyl - β -D-maltopyranoside, n-dodecyl - β -D-glucopyranoside, n-dodecyl - β -D-maltoside, heptanoyl-N-methylglucamide, n-heptyl - β -D-glucopyranoside, n-heptyl - β -D-thioglucoside, n-hexyl - β -D-glucopyranoside, nonanoyl-N-methylglucamide, n-nonyl - β -D-glucopyranoside, octanoyl-N-methylglucamide, n-octyl - β -D-glucopyranoside, octyl - β -D-thioglucopyranoside; cystine, tyrosine, tryptophan, leucine, isoleucine, phenylalanine, asparagine, aspartic acid, glutamic acid, and methionine; acetic anhydride, benzoic anhydride, ascorbic acid, 2-pyrrolidone-5-carboxylic acid, sodium pyrrolidone carboxylate, ethylenediaminetetraacetic dianhydride, maleic anhydride, succinic anhydride, diglycolic anhydride, glutaric anhydride, acetiamine, benfotiamine, pantothenic acid; cetotiamine; cycothiamine, dexpanthenol, niacinamide, nicotinic acid, pyridoxal 5-phosphate, nicotinamide ascorbate, riboflavin, riboflavin phosphate, thiamine, folic acid, menadiol diphosphate, menadione sodium bisulfite, menadoxime, vitamin B12, vitamin K5, vitamin K6, vitamin K6, and vitamin U; albumin, immunoglobulins, caseins, hemoglobins, lysozymes, immunoglobins, α -2-macroglobulin, fibronectins, vitronectins, fibrinogens, lipases, benzalkonium chloride, benzethonium chloride, docecyl trimethyl ammonium bromide, sodium docecylsulfates, dialkyl methylbenzyl ammonium chloride, and dialkylesters of sodium sulfonsuccinic acid, L-ascorbic acid and its salt, D-glucoascorbic acid and its salt, tromethamine, triethanolamine, diethanolamine, meglumine, glucamine, amine alcohols, glucoheptonic acid, glucomic acid, hydroxyl ketone, hydroxyl lactone, gluconolactone, glucoheptonolactone, glucooctanoic lactone, gulonic acid lactone, mannoic lactone, ribonic acid lactone, lactobionic acid, glucosamine, glutamic acid, benzyl alcohol, benzoic acid, hydroxybenzoic acid, propyl 4-hydroxybenzoate, lysine acetate salt, gentisic acid, lactobionic acid, lactitol, sinapic acid, vanillic acid, vanillin, methyl paraben, propyl paraben, sorbitol, xylitol, cyclodextrin, (2-hydroxypropyl)-

cyclodextrin, acetaminophen, ibuprofen, retinoic acid, lysine acetate, gentisic acid, catechin, catechin gallate, tiletamine, ketamine, propofol, lactic acids, acetic acid, salts of any organic acid and organic amine, polyglycidol, glycerol, multiglycerols, galactitol, di(ethylene glycol), tri(ethylene glycol), tetra(ethylene glycol), penta(ethylene glycol), poly(ethylene glycol) oligomers, di(propylene glycol), tri(propylene glycol), tetra(propylene glycol, and penta(propylene glycol), poly(propylene glycol) oligomers, a block copolymer of polyethylene glycol and polypropylene glycol, and derivatives and combinations thereof.

15. The medical device according to claim 1, wherein the device further comprises a dimethylsulfoxide solvent layer, wherein the dimethylsulfoxide solvent layer is overlying the surface of the layer.

16. The medical device according to claim 1, wherein the device is capable of delivering the therapeutic agent to the tissue in about 0.1 to 2 minutes.

17. The medical device according to claim 1, wherein the layer consists essentially of the therapeutic agent, the contrast agent, and the additive.

18. The medical device according to claim 1, wherein the concentration of the therapeutic agent in the layer is from 1 to 20 $\mu\text{g}/\text{mm}^2$.

19. The medical device according to claim 1, wherein the therapeutic agent is not water-soluble.

20. The medical device according to claim 1, wherein the additive enhances release of the therapeutic agent off the medical device, and wherein the therapeutic agent, the contrast agent, and the additive are released.

21. The medical device according to claim 1, wherein the additive has a water and alcohol solubility of at least 1 mg/ml, and wherein the therapeutic agent is not water-soluble.

22. A balloon catheter for delivering a therapeutic agent to a blood vessel, the catheter comprising a coating layer overlying an exterior surface of a balloon, the coating layer comprising a therapeutic agent, a contrast agent, and an additive, wherein the additive comprises a hydrophilic part and a drug affinity part, wherein the drug affinity part is at least one of a hydrophobic part, a part that has an affinity to the therapeutic agent by hydrogen bonding, and a part that has an affinity to the therapeutic agent by van der Waals interactions, wherein the additive is water-soluble, and wherein the additive is at least one of a surfactant and a chemical compound.

23. The balloon catheter according to claim 22, wherein the contrast agent is chosen from iobitridol, iohexol, iomeprol, iopamidol, iopentol, iopromide, ioversol, ioxilan, iotrolan, iodixanol, ioxaglate, and their derivatives.

24. The balloon catheter according to claim 22, wherein the surfactant is chosen from ionic, nonionic, aliphatic, and aromatic surfactants, PEG fatty esters, PEG omega-3 fatty esters, ether, and alcohols, glycerol fatty esters, sorbitan fatty esters, PEG glyceryl fatty esters, PEG sorbitan fatty esters, sugar fatty esters, PEG sugar esters, and derivatives thereof.

25. The balloon catheter according to claim 22, wherein the chemical compound has one or more hydroxyl, amino, carbonyl, carboxyl, acid, amide or ester groups.

26. The balloon catheter according to claim 25, wherein the chemical compound having one or more hydroxyl, amino, carbonyl, carboxyl, acid, amide or ester groups is chosen from amino alcohols, hydroxyl carboxylic acid, ester, and anhydrides, hydroxyl ketone, hydroxyl lactone, hydroxyl ester, sugar phosphate, sugar sulfate, ethyl oxide, ethyl glycols, amino acids, peptides, proteins, sorbitan, glycerol, polyalcohol, phosphates, sulfates, organic acids, esters, salts, vitamins, combinations of amino alcohol and organic acid, and their substituted molecules.

27. The balloon catheter according to claim 22, wherein the therapeutic agent is not water-soluble.

28. The balloon catheter according to claim 22, wherein the therapeutic agent is one of paclitaxel and analogues thereof, rapamycin and analogues thereof, beta-lapachone and analogues thereof, biological vitamin D and analogues thereof, and a mixture of these therapeutic agents.

29. The balloon catheter according to claim 22, wherein the therapeutic agent is in combination with a second therapeutic agent, wherein the therapeutic agent is one of paclitaxel, rapamycin, and analogues thereof, and wherein the second therapeutic agent is one of beta-lapachone, biological active vitamin D, and their analogues.

30. The balloon catheter according to claim 22, wherein the catheter further comprises a top layer overlying the coating layer, wherein the top layer reduces loss of the therapeutic agent during transit through a body to the blood vessel.

31. The balloon catheter according to claim 22, wherein the catheter further comprises a dimethylsulfoxide solvent layer, wherein the dimethylsulfoxide solvent layer is overlying the surface of the coating layer.

32. The balloon catheter according to claim 22, wherein the balloon catheter is capable of delivering the therapeutic agent to the blood vessel in about 0.1 to 2 minutes.

33. The balloon catheter according to claim 22, wherein the concentration of the therapeutic agent in the coating layer is from 1 to 20 $\mu\text{g}/\text{mm}^2$.

34. A balloon catheter for delivering a therapeutic agent to a blood vessel, the catheter comprising a coating layer overlying the exterior surface of a balloon, the coating layer comprising a therapeutic agent, a contrast agent, and an additive, wherein the additive comprises a hydrophilic part and a drug affinity part, wherein the drug affinity part is at least one of a hydrophobic part, a part that has an affinity to the therapeutic agent by hydrogen bonding, and a part that has an affinity to the

therapeutic agent by van der Waals interactions, wherein the additive is chosen from p-isononylphenoxypolyglycidol, PEG laurate, Tween 20, Tween 40, Tween 60, PEG oleate, PEG stearate, PEG glyceryl laurate, PEG glyceryl oleate, PEG glyceryl stearate, polyglyceryl laurate, polyglyceryl oleate, polyglyceryl myristate, polyglyceryl palmitate, polyglyceryl-6 laurate, polyglyceryl-6 oleate, polyglyceryl-6 myristate, polyglyceryl-6 palmitate, polyglyceryl-10 laurate, polyglyceryl-10 oleate, polyglyceryl-10 myristate, polyglyceryl-10 palmitate PEG sorbitan monolaurate, PEG sorbitan monolaurate, PEG sorbitan monooleate, PEG sorbitan stearate, PEG oleyl ether, PEG lauryl ether, octoxynol, monoxynol, tyloxapol, sucrose monopalmitate, sucrose monolaurate, decanoyl-N-methylglucamide, n-decyl - β -D-glucopyranoside, n-decyl - β -D-maltopyranoside, n-dodecyl - β -D-glucopyranoside, n-dodecyl - β -D-maltoside, heptanoyl-N-methylglucamide, n-heptyl - β -D-glucopyranoside, n-heptyl - β -D-thioglucoside, n-hexyl - β -D-glucopyranoside, nonanoyl-N-methylglucamide, n-nonyl - β -D-glucopyranoside, octanoyl-N-methylglucamide, n-octyl - β -D-glucopyranoside, octyl - β -D-thioglucopyranoside; cystine, tyrosine, tryptophan, leucine, isoleucine, phenylalanine, asparagine, aspartic acid, glutamic acid, and methionine; acetic anhydride, benzoic anhydride, ascorbic acid, 2-pyrrolidone-5-carboxylic acid, sodium pyrrolidone carboxylate, ethylenediaminetetraacetic dianhydride, maleic anhydride, succinic anhydride, diglycolic anhydride, glutaric anhydride, acetiamine, benfotiamine, pantothenic acid; cetotiamine; cycothiamine, dexpanthenol, niacinamide, nicotinic acid, pyridoxal 5-phosphate, nicotinamide ascorbate, riboflavin, riboflavin phosphate, thiamine, folic acid, menadiol diphosphate, menadione sodium bisulfite, menadoxime, vitamin B12, vitamin K5, vitamin K6, vitamin K6, and vitamin U; albumin, immunoglobulins, caseins, hemoglobins, lysozymes, immunoglobins, α -2-macroglobulin, fibronectins, vitronectins, fibrinogens, lipases, benzalkonium chloride, benzethonium chloride, docecyl trimethyl ammonium bromide, sodium docecylsulfates, dialkyl methylbenzyl ammonium chloride, and dialkylesters of sodium sulfonsuccinic acid, L-ascorbic acid and its salt, D-glucoascorbic acid and its salt, tromethamine, triethanolamine, diethanolamine, meglumine, glucamine, amine alcohols, glucoheptonic acid, glucomic acid, hydroxyl ketone, hydroxyl lactone, gluconolactone, glucoheptonolactone, glucooctanoic lactone, gulonic acid lactone, mannoic lactone,

ribonic acid lactone, lactobionic acid, glucosamine, glutamic acid, benzyl alcohol, benzoic acid, hydroxybenzoic acid, propyl 4-hydroxybenzoate, lysine acetate salt, gentisic acid, lactobionic acid, lactitol, sinapic acid, vanillic acid, vanillin, methyl paraben, propyl paraben, sorbitol, xylitol, cyclodextrin, (2-hydroxypropyl)-cyclodextrin, acetaminophen, ibuprofen, retinoic acid, lysine acetate, gentisic acid, catechin, catechin gallate, tiletamine, ketamine, propofol, lactic acids, acetic acid, salts of any organic acid and organic amine, polyglycidol, glycerol, multiglycerols, galactitol, di(ethylene glycol), tri(ethylene glycol), tetra(ethylene glycol), penta(ethylene glycol), poly(ethylene glycol) oligomers, di(propylene glycol), tri(propylene glycol), tetra(propylene glycol, and penta(propylene glycol), poly(propylene glycol) oligomers, a block copolymer of polyethylene glycol and polypropylene glycol, and derivatives and combinations thereof.

35. A pharmaceutical composition comprising a therapeutic agent, a contrast agent, and an additive, wherein the additive comprises a hydrophilic part and a drug affinity part, wherein the drug affinity part is at least one of a hydrophobic part, a part that has an affinity to the therapeutic agent by hydrogen bonding, and a part that has an affinity to the therapeutic agent by van der Waals interactions, wherein the additive is water-soluble, wherein the additive is at least one of a surfactant and a chemical compound.

36. The pharmaceutical composition according to claim 35, wherein the contrast agent is chosen from iobitridol, iohexol, iomeprol, iopamidol, iopentol, iopromide, ioversol, ioxilan, iotrolan, iodixanol, ioxaglate, and their derivatives.

37. The pharmaceutical composition according to claim 35, wherein the surfactant is chosen from ionic, nonionic, aliphatic, and aromatic surfactants, PEG fatty esters, PEG omega-3 fatty esters, ether, and alcohols, glycerol fatty esters, sorbitan fatty esters, PEG glyceryl fatty esters, PEG sorbitan fatty esters, sugar fatty esters, PEG sugar esters and derivatives thereof.

38. The pharmaceutical composition according to claim 35, wherein the chemical compound has one or more hydroxyl, amino, carbonyl, carboxyl, acid, amide or ester groups.

39. The pharmaceutical composition according to claim 38, wherein the chemical compound having one or more hydroxyl, amino, carbonyl, carboxyl, acid, amide or ester groups is chosen from amino alcohols, hydroxyl carboxylic acid, ester, and anhydrides, hydroxyl ketone, hydroxyl lactone, hydroxyl ester, sugar phosphate, sugar sulfate, ethyl oxide, ethyl glycols, amino acids, peptides, proteins, sorbitan, glycerol, polyalcohol, phosphates, sulfates, organic acids, esters, salts, vitamins, combinations of amino alcohol and organic acid, and their substituted molecules.

40. The pharmaceutical composition according to claim 35, wherein the additive is chosen from p-isononylphenoxypolyglycidol, PEG laurate, Tween 20, Tween 40, Tween 60, PEG oleate, PEG stearate, PEG glyceryl laurate, PEG glyceryl oleate, PEG glyceryl stearate, polyglyceryl laurate, polyglyceryl oleate, polyglyceryl myristate, polyglyceryl palmitate, polyglyceryl-6 laurate, polyglyceryl-6 oleate, polyglyceryl-6 myristate, polyglyceryl-6 palmitate, polyglyceryl-10 laurate, polyglyceryl-10 oleate, polyglyceryl-10 myristate, polyglyceryl-10 palmitate PEG sorbitan monolaurate, PEG sorbitan monolaurate, PEG sorbitan monooleate, PEG sorbitan stearate, PEG oleyl ether, PEG lauryl ether, octoxynol, monoxynol, tyloxapol, sucrose monopalmitate, sucrose monolaurate, decanoyl-N-methylglucamide, n-decyl - β -D-glucopyranoside, n-decyl - β -D-maltopyranoside, n-dodecyl - β -D-glucopyranoside, n-dodecyl - β -D-maltoside, heptanoyl-N-methylglucamide, n-heptyl - β -D-glucopyranoside, n-heptyl - β -D-thioglucoside, n-hexyl - β -D-glucopyranoside, nonanoyl-N-methylglucamide, n-nonyl - β -D-glucopyranoside, octanoyl-N-methylglucamide, n-octyl - β -D-glucopyranoside, octyl - β -D-thioglucopyranoside; cystine, tyrosine, tryptophan, leucine, isoleucine, phenylalanine, asparagine, aspartic acid, glutamic acid, and methionine; acetic anhydride, benzoic anhydride, ascorbic acid, 2-pyrrolidone-5-carboxylic acid, sodium pyrrolidone carboxylate, ethylenediaminetetraacetic dianhydride, maleic

and anhydride, succinic anhydride, diglycolic anhydride, glutaric anhydride, acetiamine, benfotiamine, pantothenic acid; cetotiamine; cycothiamine, dexpanthenol, niacinamide, nicotinic acid, pyridoxal 5-phosphate, nicotinamide ascorbate, riboflavin, riboflavin phosphate, thiamine, folic acid, menadiol diphosphate, menadione sodium bisulfite, menadoxime, vitamin B12, vitamin K5, vitamin K6, vitamin K6, and vitamin U; albumin, immunoglobulins, caseins, hemoglobins, lysozymes, immunoglobins, a-2-macroglobulin, fibronectins, vitronectins, firbinogens, lipases, benzalkonium chloride, benzethonium chloride, docecyl trimethyl ammonium bromide, sodium docecylsulfates, dialkyl methylbenzyl ammonium chloride, and dialkylesters of sodium sulfonsuccinic acid, L-ascorbic acid and its salt, D-glucoascorbic acid and its salt, tromethamine, triethanolamine, diethanolamine, meglumine, glucamine, amine alcohols, glucoheptonic acid, glucomic acid, hydroxyl ketone, hydroxyl lactone, gluconolactone, glucoheptonolactone, glucooctanoic lactone, gulonic acid lactone, mannoic lactone, ribonic acid lactone, lactobionic acid, glucosamine, glutamic acid, benzyl alcohol, benzoic acid, hydroxybenzoic acid, propyl 4-hydroxybenzoate, lysine acetate salt, gentisic acid, lactobionic acid, lactitol, sinapic acid, vanillic acid, vanillin, methyl paraben, propyl paraben, sorbitol, xylitol, cyclodextrin, (2-hydroxypropyl)-cyclodextrin, acetaminophen, ibuprofen, retinoic acid, lysine acetate, gentisic acid, catechin, catechin gallate, tiletamine, ketamine, propofol, lactic acids, acetic acid, salts of any organic acid and organic amine, polyglycidol, glycerol, multiglycerols, galactitol, di(ethylene glycol), tri(ethylene glycol), tetra(ethylene glycol), penta(ethylene glycol), poly(ethylene glycol) oligomers, di(propylene glycol), tri(propylene glycol), tetra(propylene glycol, and penta(propylene glycol), poly(propylene glycol) oligomers, a block copolymer of polyethylene glycol and polypropylene glycol, and derivatives and combinations thereof.

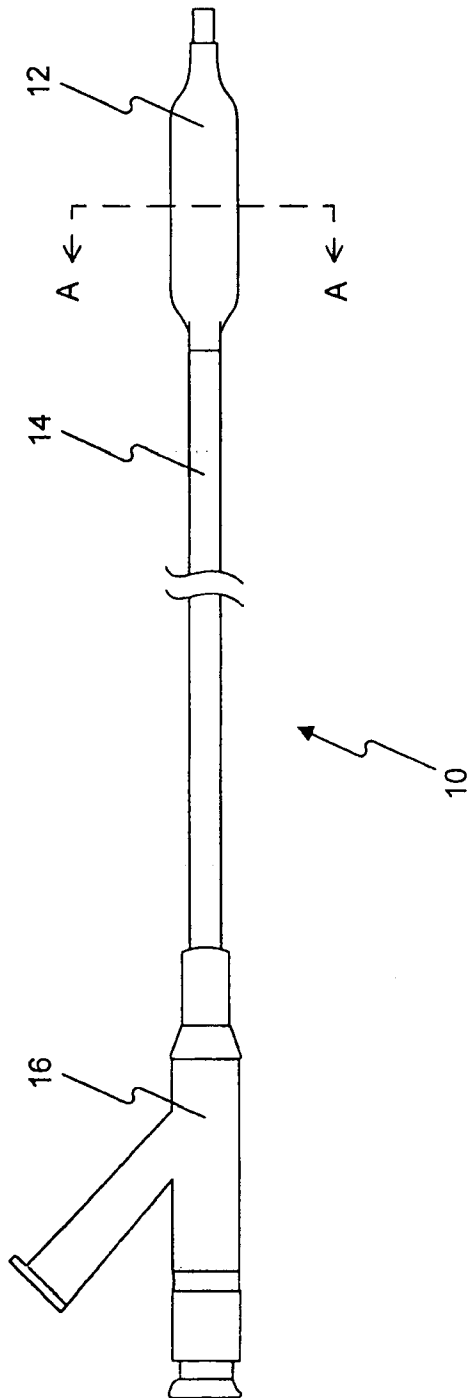
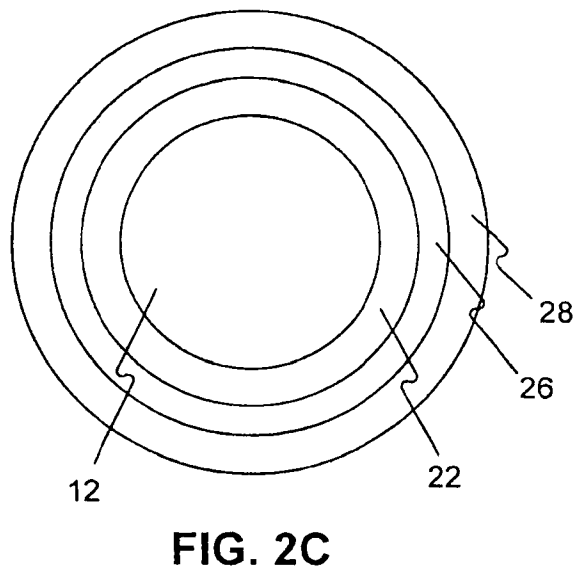
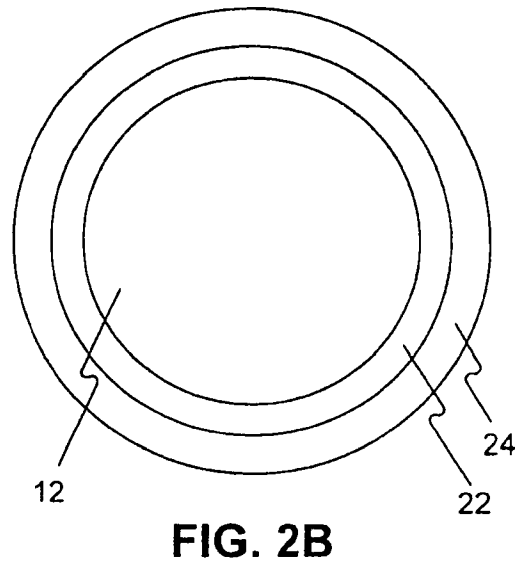
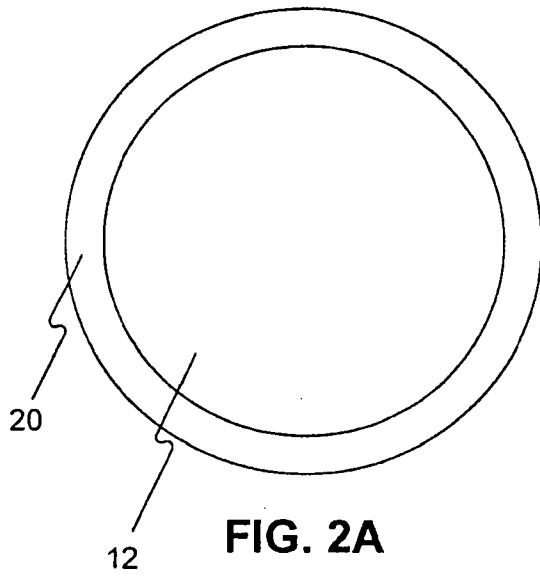

FIG. 1



INTERNATIONAL SEARCH REPORT

International application No
PCT/US2008/006417

A. CLASSIFICATION OF SUBJECT MATTER
 INV. A61L29/16 A61L31/16 A61L31/18 A61L29/18 A61K45/06

According to International Patent Classification (IPC) or to both national classification and IPC

B. FIELDS SEARCHED
 Minimum documentation searched (classification system followed by classification symbols)
 A61L A61K

Documentation searched other than minimum documentation to the extent that such documents are included in the fields searched

Electronic data base consulted during the international search (name of data base and, where practical, search terms used)
 EPO-Internal, WPI Data, INSPEC, MEDLINE, EMBASE, BIOSIS

C. DOCUMENTS CONSIDERED TO BE RELEVANT

Category*	Citation of document, with indication, where appropriate, of the relevant passages	Relevant to claim No.
Y	EP 1 666 070 A (SPECK ULRICH [DE] BAYER SCHERING PHARMA AG [DE]) 7 June 2006 (2006-06-07) abstract paragraph [0015] paragraph [0024]; claims 1-13; examples 1-8	1-40
Y	US 2006/188543 A1 (FENG SI-SHEN [SG]) 24 August 2006 (2006-08-24) paragraph [0009] paragraph [0054]	1-40
Y	US 2005/238584 A1 (ANNAPRAGADA ANANTH [US] ET AL) 27 October 2005 (2005-10-27) abstract example 1	1-40
	----- -/--	

Further documents are listed in the continuation of Box C. See patent family annex.

* Special categories of cited documents :

A document defining the general state of the art which is not considered to be of particular relevance	*T* later document published after the international filing date or priority date and not in conflict with the application but cited to understand the principle or theory underlying the invention
E earlier document but published on or after the international filing date	*X* document of particular relevance; the claimed invention cannot be considered novel or cannot be considered to involve an inventive step when the document is taken alone
L document which may throw doubts on priority claim(s) or which is cited to establish the publication date of another citation or other special reason (as specified)	*Y* document of particular relevance; the claimed invention cannot be considered to involve an inventive step when the document is combined with one or more other such documents, such combination being obvious to a person skilled in the art.
O document referring to an oral disclosure, use, exhibition or other means	*Z* document member of the same patent family
P document published prior to the international filing date but later than the priority date claimed	

Date of the actual completion of the international search 6 November 2008	Date of mailing of the international search report 24/11/2008
--	--

Name and mailing address of the ISA/ European Patent Office, P.B. 5818 Patentlaan 2 NL - 2280 HV Rijswijk Tel. (+31-70) 340-2040, Fax: (+31-70) 340-3016	Authorized officer Laffargue-Haak, T
--	---

INTERNATIONAL SEARCH REPORT

International application No
PCT/US2008/006417

C(Continuation). DOCUMENTS CONSIDERED TO BE RELEVANT		
Category*	Citation of document, with indication, where appropriate, of the relevant passages	Relevant to claim No.
Y	WO 98/02114 A (HERCULES INC [US]) 22 January 1998 (1998-01-22) example 4 -----	1-40
P,X	WO 2007/149161 A (BOSTON SCIENT SCIMED INC [US]; KANGAS STEVE [US]) 27 December 2007 (2007-12-27) abstract -----	1-40
E	WO 2008/063576 A (LUTONIX INC [US]; WANG LIXIAO [US]) 29 May 2008 (2008-05-29) the whole document -----	1-40
P,X	WO 2008/003298 A (HEMOTEQ AG [DE]; HOFFMANN ERIKA [DE]; HOFFMANN MICHAEL [DE]; HORRES RO) 10 January 2008 (2008-01-10) the whole document -----	1-40
P,X	WO 2007/139931 A (ABBOTT CARDIOVASCULAR SYSTEMS [US]; GUERIGUIAN VINCENT J [US]; HUANG B) 6 December 2007 (2007-12-06) the whole document -----	1-40
P,X	WO 2007/134239 A (CORDIS CORP [US]; BURGERMEISTER ROBERT [US]; DAVE VIPUL BHUPENDRA [US]) 22 November 2007 (2007-11-22) the whole document -----	1-40
P,X	EP 1 913 962 A (PERELSON OPHIR [US]) 23 April 2008 (2008-04-23) the whole document -----	1-40

INTERNATIONAL SEARCH REPORT

International application No.
PCT/US2008/006417

Box No. II Observations where certain claims were found unsearchable (Continuation of item 2 of first sheet)

This international search report has not been established in respect of certain claims under Article 17(2)(a) for the following reasons:

1. Claims Nos.:
because they relate to subject matter not required to be searched by this Authority, namely:

2. Claims Nos.: 1-40
because they relate to parts of the international application that do not comply with the prescribed requirements to such an extent that no meaningful international search can be carried out, specifically:
see FURTHER INFORMATION sheet PCT/ISA/210

3. Claims Nos.:
because they are dependent claims and are not drafted in accordance with the second and third sentences of Rule 6.4(a).

Box No. III Observations where unity of invention is lacking (Continuation of item 3 of first sheet)

This International Searching Authority found multiple inventions in this international application, as follows:

1. As all required additional search fees were timely paid by the applicant, this international search report covers allsearchable claims.

2. As all searchable claims could be searched without effort justifying an additional fees, this Authority did not invite payment of additional fees.

3. As only some of the required additional search fees were timely paid by the applicant, this international search report covers only those claims for which fees were paid, specifically claims Nos.:

4. No required additional search fees were timely paid by the applicant. Consequently, this international search report is restricted to the invention first mentioned in the claims; it is covered by claims Nos.:

Remark on Protest

- The additional search fees were accompanied by the applicant's protest and, where applicable, the payment of a protest fee.
- The additional search fees were accompanied by the applicant's protest but the applicable protest fee was not paid within the time limit specified in the invitation.
- No protest accompanied the payment of additional search fees.

FURTHER INFORMATION CONTINUED FROM PCT/ISA/ 210

Continuation of Box II.2

Claims Nos.: 1-40

The present application contains 40 claims, of which 5 are independent. There is no clear distinction between the independent claims because of overlapping scope. There are so many claims, and they are drafted in such a way that the claims as a whole are not in compliance with the provisions of clarity and conciseness of Article 6 PCT, as it is particularly burdensome for a skilled person to establish the subject-matter for which protection is sought. The non-compliance with the substantive provisions is to such an extent, that the search was performed taking into consideration the non-compliance in determining the extent of the search (PCT Guidelines 9.19 and 9.25).

The additive is only defined as in independent claims 1, 22 and 35 as being "water-soluble" and being "a surfactant and a chemical compound"

The search was based on the subject-matter that, as far as can be understood, could reasonably be expected to be claimed later in the procedure, namely the examples 1-12 .

The applicant's attention is drawn to the fact that claims relating to inventions in respect of which no international search report has been established need not be the subject of an international preliminary examination (Rule 66.1(e) PCT). The applicant is advised that the EPO policy when acting as an International Preliminary Examining Authority is normally not to carry out a preliminary examination on matter which has not been searched. This is the case irrespective of whether or not the claims are amended following receipt of the search report or during any Chapter II procedure. If the application proceeds into the regional phase before the EPO, the applicant is reminded that a search may be carried out during examination before the EPO (see EPO Guideline C-VI, 8.2), should the problems which led to the Article 17(2)PCT declaration be overcome.

INTERNATIONAL SEARCH REPORT

Information on patent family members

International application No

PCT/US2008/006417

Patent document cited in search report		Publication date	Patent family member(s)	Publication date
EP 1666070	A	07-06-2006	AT 9810 U1	15-04-2008
			AT 334703 T	15-08-2006
			AT 372131 T	15-09-2007
			AT 369879 T	15-09-2007
			AU 2006222697 A1	19-10-2006
			AU 2006222699 A1	19-10-2006
			AU 2006222702 A1	19-10-2006
			BR 0116945 A	09-03-2004
			CA 2442080 A1	03-10-2002
			CN 1494435 A	05-05-2004
			CN 1824311 A	30-08-2006
			CN 1935277 A	28-03-2007
			CN 1899614 A	24-01-2007
			CN 1899615 A	24-01-2007
			CZ 20032293 A3	17-12-2003
			WO 02076509 A2	03-10-2002
			DE 10115740 A1	02-10-2002
			DE 20122582 U1	08-06-2006
			DE 20122735 U1	28-06-2007
			DK 1372737 T3	27-11-2006
			DK 1666070 T3	14-01-2008
			DK 1666071 T3	07-01-2008
			EP 1372737 A2	02-01-2004
			EP 1669092 A1	14-06-2006
			EP 1666071 A1	07-06-2006
			ES 2269500 T3	01-04-2007
			ES 2289720 T3	01-02-2008
			ES 2289721 T3	01-02-2008
			HK 1064296 A1	05-01-2007
			HU 0303598 A2	28-05-2004
			JP 2004524346 T	12-08-2004
			MX PA03008368 A	12-11-2004
			NZ 527825 A	24-03-2005
			US 2005101522 A1	12-05-2005
			US 2008102033 A1	01-05-2008
			ZA 200306806 A	17-02-2004
US 2006188543	A1	24-08-2006	NONE	
US 2005238584	A1	27-10-2005	AU 2005239980 A1	17-11-2005
			CA 2563692 A1	17-11-2005
			CN 101123996 A	13-02-2008
			EP 1742669 A1	17-01-2007
			JP 2007533737 T	22-11-2007
			US 2008131369 A1	05-06-2008
			US 2007212303 A1	13-09-2007
			WO 2005107820 A1	17-11-2005
WO 9802114	A	22-01-1998	CA 2261806 A1	22-01-1998
			DE 69734201 D1	20-10-2005
			DE 69734201 T2	06-07-2006
			EP 0912145 A1	06-05-1999
			US 5820918 A	13-10-1998
WO 2007149161	A	27-12-2007	US 2007298067 A1	27-12-2007
WO 2008063576	A	29-05-2008	US 2008118544 A1	22-05-2008
			US 2008175887 A1	24-07-2008

INTERNATIONAL SEARCH REPORT

Information on patent family members

International application No

PCT/US2008/006417

Patent document cited in search report	Publication date	Patent family member(s)	Publication date
WO 2008063576 A		WO 2008063581 A2	29-05-2008
WO 2008003298 A	10-01-2008	NONE	
WO 2007139931 A	06-12-2007	US 2008009939 A1	10-01-2008
WO 2007134239 A	22-11-2007	US 2008046068 A1	21-02-2008
EP 1913962 A	23-04-2008	WO 2008087488 A2	24-07-2008