

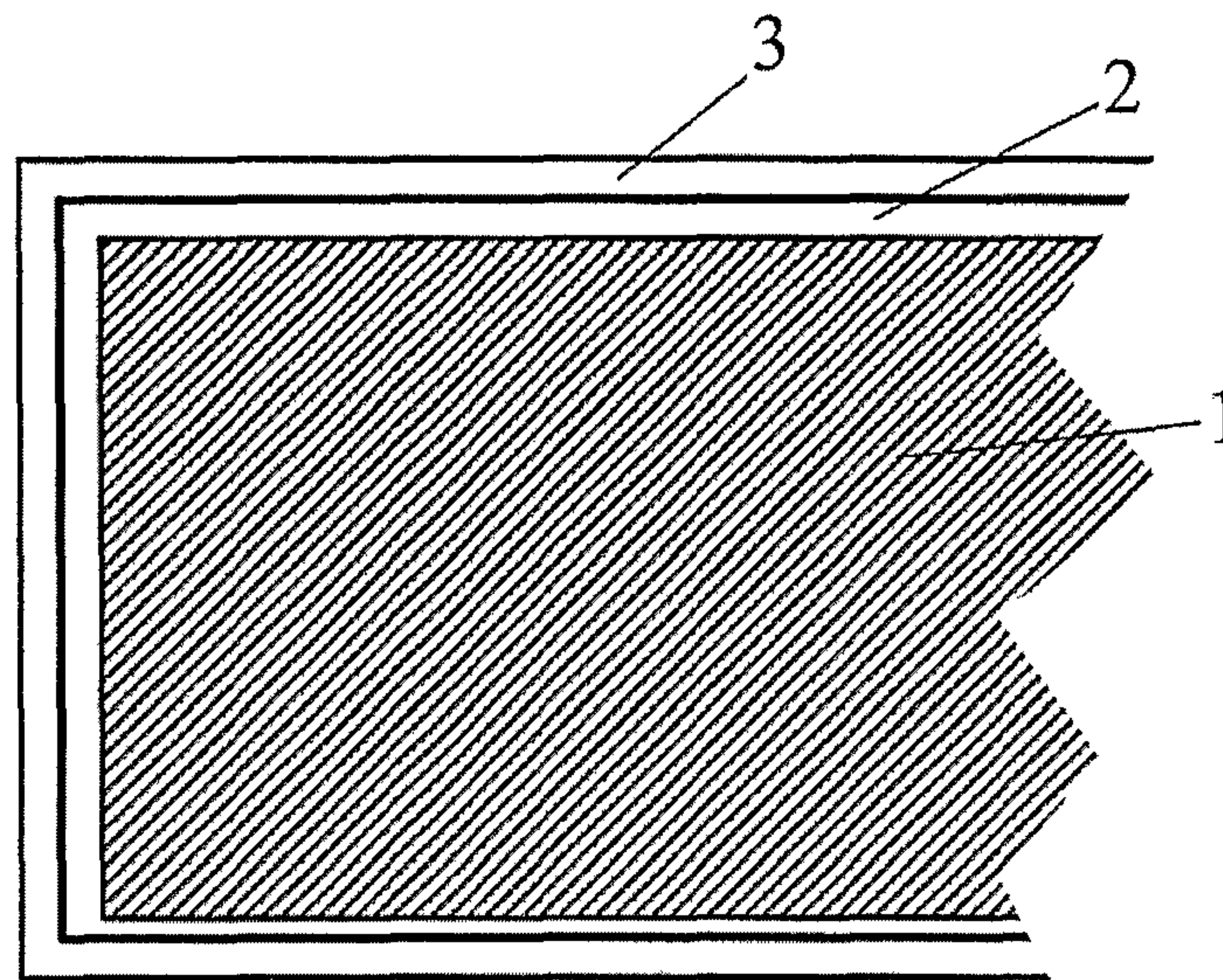

(86) Date de dépôt PCT/PCT Filing Date: 2004/11/22  
(87) Date publication PCT/PCT Publication Date: 2005/06/09  
(85) Entrée phase nationale/National Entry: 2006/05/11  
(86) N° demande PCT/PCT Application No.: GB 2004/004942  
(87) N° publication PCT/PCT Publication No.: 2005/051134  
(30) Priorité/Priority: 2003/11/21 (GB0327138.4)

(51) Cl.Int./Int.Cl. *A47C 21/06* (2006.01),  
*A61F 5/48* (2006.01)  
(71) Demandeur/Applicant:  
UCL BIOMEDICA PLC, GB  
(72) Inventeurs/Inventors:  
BAIN, DUNCAN, GB;  
PELL, MARTIN FERGUSON, GB;  
NICHOLSON, GRAHAM, GB  
(74) Agent: MARKS & CLERK

(54) Titre : PROTECTION DE MATELAS  
(54) Title: MATTRESS PROTECTION



(57) **Abrégé/Abstract:**

The present invention seeks to address the chronic and worsening problem of mattress management in hospitals by providing a mattress protector to shield a mattress or mattress core from body fluids, the protector not only comprising a shielding cover for the mattress (1) or mattress core but also a detector in an inter- or under-layer (2) of the cover to detect body fluid that has passed into or through the cover. The detector may be chemical, with the cover being a transparent cover (3) and the under-layer being absorbent and having a dye that is activated by a body fluid to provide a visual indication of presence of the body fluid. In an alternative embodiment the detector may be an apparatus monitoring electrical conductivity. This suitably uses threads of electrically conductive yarn forming either the warp or weft of a thin flexible under layer of the protective cover (5) and which are linked to a small processor (7) which monitors the electrical conductivity between neighbouring conductive threads in the sensing layer.



(12) INTERNATIONAL APPLICATION PUBLISHED UNDER THE PATENT COOPERATION TREATY (PCT)

(19) World Intellectual Property  
Organization  
International Bureau



(43) International Publication Date  
9 June 2005 (09.06.2005)

PCT

(10) International Publication Number  
**WO 2005/051134 A1**

- (51) International Patent Classification<sup>7</sup>: A47C 21/06, A61F 5/48
- (21) International Application Number: PCT/GB2004/004942
- (22) International Filing Date: 22 November 2004 (22.11.2004)
- (25) Filing Language: English
- (26) Publication Language: English
- (30) Priority Data: 0327138.4 21 November 2003 (21.11.2003) GB
- (71) Applicant (for all designated States except US): UCL BIOMEDICA PLC [GB/GB]; Royal Free & University College Medical School, University College London, Royal Free Campus, Rowland Hill Street, London NW3 2PF (GB).
- (72) Inventors; and
- (75) Inventors/Applicants (for US only): BAIN, Duncan [GB/GB]; 531a North Deeside Road, Aberdeen, Scotland (GB). PELL, Martin, Ferguson [GB/GB]; 9 The Leys, Chesham Bois, Buckinghamshire HP6 5NP (GB). NICHOLSON, Graham [GB/GB]; 41 The Gardens Harrow, Middlesex HA7 4HE (GB).
- (74) Agent: WHITAKER, Iain, Mark; Marks & Clerk, 45 Grosvenor Road, St Albans AL1 3AW (GB).
- (81) Designated States (unless otherwise indicated, for every kind of national protection available): AE, AG, AL, AM, AT, AU, AZ, BA, BB, BG, BR, BW, BY, BZ, CA, CH, CN, CO, CR, CU, CZ, DE, DK, DM, DZ, EC, EE, EG, ES, FI, GB, GD, GE, GH, GM, HR, HU, ID, IL, IN, IS, JP, KE, KG, KP, KR, KZ, LC, LK, LR, LS, LT, LU, LV, MA, MD, MG, MK, MN, MW, MX, MZ, NA, NI, NO, NZ, OM, PG, PH, PL, PT, RO, RU, SC, SD, SE, SG, SK, SL, SY, TJ, TM, TN, TR, TT, TZ, UA, UG, US, UZ, VC, VN, YU, ZA, ZM, ZW.
- (84) Designated States (unless otherwise indicated, for every kind of regional protection available): ARIPO (BW, GH, GM, KE, LS, MW, MZ, NA, SD, SL, SZ, TZ, UG, ZM, ZW), Eurasian (AM, AZ, BY, KG, KZ, MD, RU, TJ, TM), European (AT, BE, BG, CH, CY, CZ, DE, DK, EE, ES, FI, FR, GB, GR, HU, IE, IS, IT, LU, MC, NL, PL, PT, RO, SE, SI, SK, TR), OAPI (BF, BJ, CF, CG, CI, CM, GA, GN, GQ, GW, ML, MR, NE, SN, TD, TG).
- Published:**
- with international search report
  - before the expiration of the time limit for amending the claims and to be republished in the event of receipt of amendments
- For two-letter codes and other abbreviations, refer to the "Guidance Notes on Codes and Abbreviations" appearing at the beginning of each regular issue of the PCT Gazette.

(54) Title: MATTRESS PROTECTION

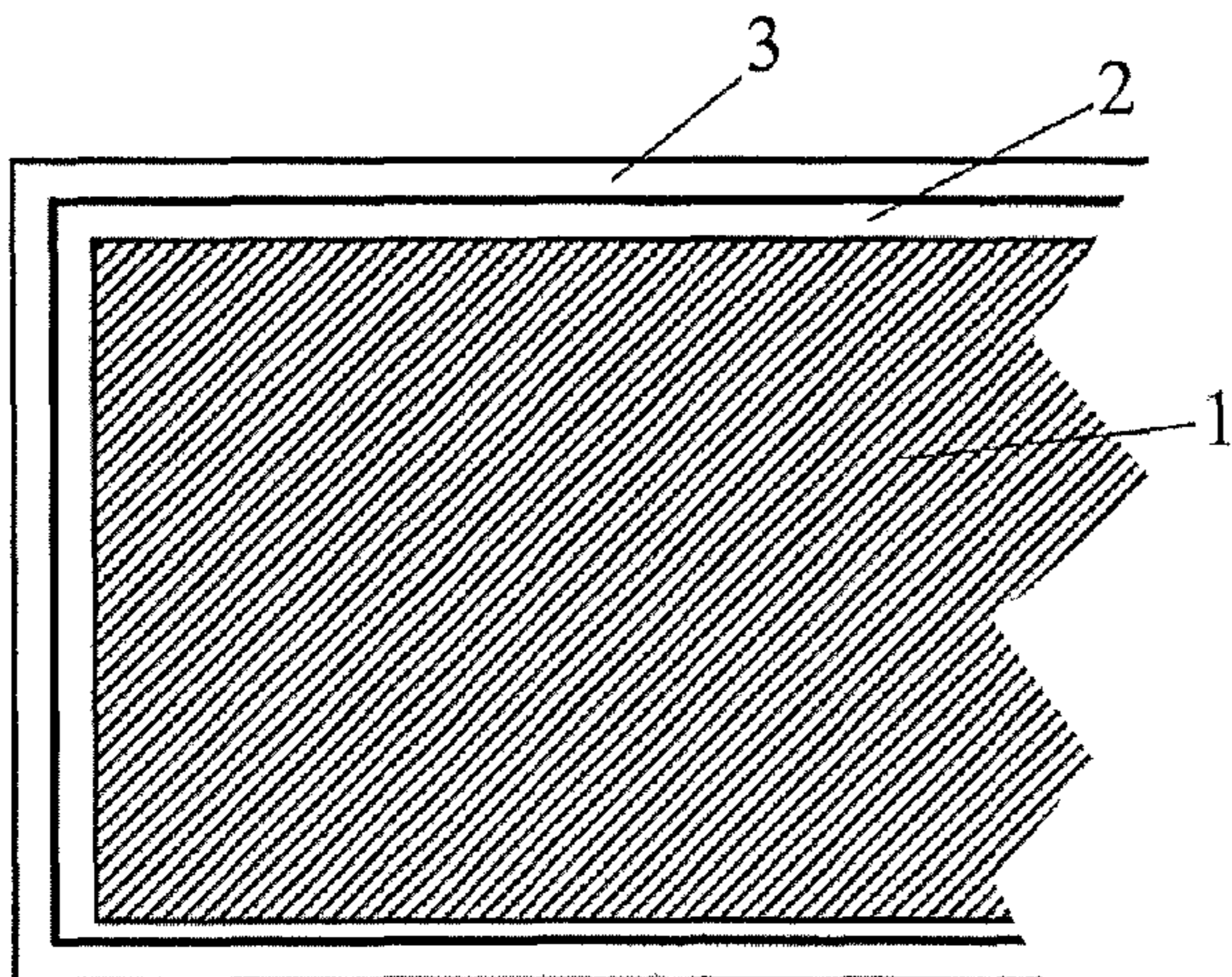

(57) Abstract: The present invention seeks to address the chronic and worsening problem of mattress management in hospitals by providing a mattress protector to shield a mattress or mattress core from body fluids, the protector not only comprising a shielding cover for the mattress (1) or mattress core but also a detector in an inter or under-layer (2) of the cover to detect body fluid that has passed into or through the cover. The detector may be chemical, with the cover being a transparent cover (3) and the under-layer being absorbent and having a dye that is activated by a body fluid to provide a visual indication of presence of the body fluid. In an alternative embodiment the detector may be an apparatus monitoring electrical conductivity. This suitably uses threads of electrically conductive yarn forming either the warp or weft of a thin flexible under layer of the protective cover (5) and which are linked to a small processor (7) which monitors the electrical conductivity between neighbouring conductive threads in the sensing layer.

WO 2005/051134 A1

## **Mattress Protection**

### **Field of the Invention**

- 5 The present invention concerns improvements in and relating to mattress protectors and provides methods and means for monitoring the integrity of a mattress protector to determine if bodily fluids have penetrated through to the mattress.

### **Background to the Invention**

10

Hospital mattresses form the platform for delivering routine care to patients. In recent years increasing attention has been paid to their specifications, including their ability to improve comfort for patients, prevent pressure ulcers, appropriately stabilise patients with fractures or following surgery, reduce the risk of rolling off the mattress, and facilitate nursing management of the patients including toileting. A further requirement is that mattress covers be impenetrable to body fluids so that the inner core, which usually comprises a composite of foams, does not become contaminated. Once the integrity of the cover has been breached (technically known as "strike-through"), the potential for the mattress core to become a medium for the growth of bacteria and fungal spores is high. The combined presence of moisture, infectious agents and the warmth continuously generated by the multiple users of the mattress is an ideal incubation environment for pathogens.

15

20

In September 1999 the Medical Devices Agency issued a Safety Notice (MDA SN1999 (31) alerting hospitals of the hazards to staff and patients associated with mattresses in poor condition. In recent years procedures for supplying and servicing mattresses in hospitals have changed. Traditionally nursing staff have ordered, cleaned and audited the condition of mattresses, but with increasing pressure on their time, non-patient contact activities such as mattress management are being increasingly devolved to non-nursing staff. The UK is leading Europe in the implementation of "total mattress management" and "total bed management" contracts where the manufacturer/distributors of hospital mattress are contracted to supply mattresses against clinical and technical specifications. These specifications are led by the NHS Purchasing and Supply Agency (PASA).

25

30

35

Under these arrangements contractors undertake the responsibility of not only supplying hospital mattresses but also auditing their condition, ensuring that worn or leaking mattresses are withdrawn and replaced. At present this entails technicians undertaking a "sweep" through the hospital inspecting mattresses individually, physically checking for deterioration of the mechanical support characteristics of the mattress core, and inspecting for evidence of "strike-through". This is a very unpleasant process and may also represent a potential health and safety risk to staff undertaking the audits.

This invention seeks as one objective to provide a new technology to enable mattress audit technicians or hospital staff to determine whether a mattress cover has leaked at any time in the mattress' service, without removing the cover. Avoiding the necessity of removing the mattress cover both simplifies the task and reduces the risk of infections spreading.

15

### **Summary of the Invention**

According to a first aspect of the present invention there is provided a mattress protector to shield a mattress or mattress core from body fluids, the protector comprising a shielding cover for the mattress or mattress core, the shielding cover having a layer that is impermeable to body fluids, and a detector within the cover or below or in an under layer of the cover, the detector being below the impermeable layer of the shielding cover, to detect body fluid that has passed into or through the cover, the fluid having penetrated the impermeable layer of the shielding cover. The protector may be separate from or integral with a mattress and, in the latter case, may comprise all or part of the casing that envelopes the mattress core. The substantially liquid-impermeable cover is preferably breathable.

In a first preferred embodiment of the invention the cover is a transparent cover for a mattress with an inter-layer or under-layer, suitably an absorbent under-layer, having a dye that is activated by a body fluid to provide a visual indication of presence of the body fluid. The inter- or under-layer is preferably impregnated with the dye.

The dye is preferably unaffected by water vapour. However, if body fluid such as urine penetrates through the mattress, indicators in the dye will show through the

transparent cover. An indicator specific to urine and unaffected by water (many of which are commercially available and are used, for example, to expose urination in swimming pools) is advantageous, since water vapour may be present in the mattress during correct functioning of the cover, where the cover is specified to be  
5 "breathable", i.e. transmits water vapour.

Preferably, the absorbent layer is made from a stretchable material, suitably crepe or similar, in order to minimise perturbation of the cover stretch properties. Alternatively, incisions could be made in the absorbent sheet, similar to those in  
10 lattice pastry or expanded sheet metal, so as to allow stretch in the sheet material.

In a second preferred embodiment of the invention, instead of having a dye-based detector the detector comprises an apparatus that monitors electrical conductivity. This suitably uses electrically conductive threads or fibres such as, for example, an  
15 electrically conductive yarn (eg, silver plated nylon), forming rows or a matrix over the inter- or under-layer. Suitably the threads form the warp or weft of a thin flexible woven under- layer.

Preferably the mattress in this second embodiment is fitted with a small processor,  
20 preferably a micro-processor, which monitors the electrical conductivity between neighbouring conductive threads in the sensing layer and records any change.

In the event of a leak of ionic (electrically conductive) fluid, as all body fluids are, a short circuit between threads will be detected and recorded. The micro-processor  
25 may have a very low power consumption and could be battery-powered and be interrogated using an inductive link by an external device to determine if any leak events had occurred.

### Brief Description of the Drawings

5 The preferred embodiments of the present invention will now be more particularly described by way of example with reference to the accompanying drawings, wherein:

10 Figure 1 is a sectional view of an end of a mattress encased in the mattress protector of the first preferred embodiment;

Figure 2 is an isometric view of a mattress encased in a mattress protector of the second preferred embodiment, showing the outer cover part cut-away to view the matrix of electrically conductive yarn that underlies the outer cover;

15

Figure 3 is a schematic circuit diagram for the electrical conductivity-based detector of the second preferred embodiment;

20 Figure 4 is a further schematic circuit diagram for the electrical conductivity-based detector of the second preferred embodiment showing an example suitable geometry of the positive and negative tracks of the detector;

Figure 5 is a photographic image of a first example of electrical conductivity-based detector having a 14.5mm conductor repeat interval, labelled Specimen MLSF001;

25

Figure 6 is a photographic image of a second example of electric conductivity-based detector having a 11.6mm conductor repeat interval, labelled Specimen MLSF002;

30 Figure 7 is a photographic image of a third example of electrical conductivity-based detector having a 4.9mm conductor repeat interval, labelled Specimen MLSF003;

Figure 8 is a graph of change in resistance over an elapsed time period measured in seconds on wetting MLSF001 with distilled water, 1<sup>st</sup> run;

35 Figure 9 is a graph of change in resistance over an elapsed time period measured in seconds on wetting MLSF001 with distilled water, 2nd run;

Figure 10 is a graph of change in resistance over an elapsed time period measured in seconds on wetting MLSF001 with 4% saline solution, 1<sup>st</sup> run;

5 Figure 11 is a graph of change in resistance over an elapsed time period measured in seconds on wetting MLSF001 with 4% saline solution, 2nd run;

Figure 12 is a graph of change in resistance over an elapsed time period measured in seconds on wetting MLSF002 with distilled water, 1<sup>st</sup> run;

10

Figure 13 is a graph of change in resistance over an elapsed time period measured in seconds on wetting MLSF002 with distilled water, 2nd run;

15 Figure 14 is a graph of change in resistance over an elapsed time period measured in seconds on wetting MLSF002 with 4% saline solution, 1<sup>st</sup> run;

Figure 15 is a graph of change in resistance over an elapsed time period measured in seconds on wetting MLSF002 with 4% saline solution, 2nd run;

20 Figure 16 is a graph of change in resistance over an elapsed time period measured in seconds on wetting MLSF003 with distilled water, 1<sup>st</sup> run;

Figure 17 is a graph of change in resistance over an elapsed time period measured in seconds on wetting MLSF003 with distilled water, 2nd run;

25

Figure 18 is a graph of change in resistance over an elapsed time period measured in seconds on wetting MLSF003 with 4% saline solution, 1<sup>st</sup> run;

30 Figure 19 is a graph of change in resistance over an elapsed time period measured in seconds on wetting MLSF003 with 4% saline solution, 2nd run; and

Figure 20 is a schematic circuit diagram similar to Figure 4 but in which the positive and negative conductor tracks are in an expandable sheet that is slitted between tracks to facilitate stretching of the sheet in the direction marked by the arrow.

35

### Description of the Preferred Embodiments

5 In the first preferred embodiment, illustrated in Figure 1, a transparent cover 3 is provided for the mattress 1, with an absorbent under-layer 2 impregnated with a dye that is activated by a body fluid such as urine but not by water vapour. If urine penetrates through the mattress indicators in the dye show through the transparent cover. An indicator specific to urine, or rather specific for organic compounds such as urea or glucose present in urine, is advantageous, since water vapour may be present in the mattress during correct functioning of the cover. Many mattress covers are specified to be "breathable", i.e. they transmit water vapour. Alternatively, a moisture-sensitive dye sensitive to a threshold level of moisture greater than that prevalent as water vapour may be used.

10  
15 The absorbent layer is here stretchable, suitably being made from a stretchable fabric, eg a crepe-style material, or is incised/ partitioned, in order to minimise perturbation of the cover stretch properties.

20 In the second preferred embodiment illustrated in Figures 2 and 3, threads of electrically conductive silver plated nylon yarn are used forming the warp or weft of a thin flexible woven under layer 6 of the mattress protector beneath the substantially liquid impermeable shielding layer 5 of the cover. The mattress 4 is fitted with a small microprocessor 7, which monitors the electrical conductivity between neighbouring conductive threads 12, 13 in the sensing layer 6. In the event of a leak of ionic (electrically conductive) fluid, a short circuit between threads is detected via the threads 12,13 and recorded by the microprocessor 7. The microprocessor 7 has a very low power consumption and is thus battery powered and entirely self-contained. It can be interrogated using an inductive link by an external device to determine if any leak events had occurred.

30

Referring to Figure 3, a battery 8 supplies power to the microprocessor 7 as well as supplying positive and negative threads 12 and 13 respectively. The presence of an electrolyte such as urine 10 causes a short circuit between the two threads 12 and 13, so changing the high/low state monitored at digital input 11 to the microprocessor 7. This event is stored in the memory of the microprocessor 7.

35

At some subsequent occasion, the assembly is interrogated by means of a radio wand, the signal of which is picked up by antenna 14. This causes the microprocessor 7 to respond with an appropriate signal to indicate whether a short has occurred at any time in the past.

5

This remote interrogation of the microprocessor 7 can take place using conventional RFID technology, without the necessity of removing the mattress cover 5 (so causing a spread of infection), or even the bedclothes.

10 In one embodiment, the circuit is completed by the presence of a leak that joins any two or more adjacent lines (weft bars of conductive yarn). The tracks of conductive yarn can be produced in various geometries to provide suitable adjacent positive and negative tracks at appropriate spacings over the mattress surface. An example of this system is illustrated in principle in figure 4.

15

#### Experimental Examples

Sample devices were constructed as follows:

20 One rectangular piece of conductive-striped fabric was cut from bulk, 250 mm x 260 mm, with longer dimension weft-ways (across width).

Two rectangular pieces of fusible interfacing were cut from bulk, 250 mm x 30 mm, one fused to each shorter edge of the conductive-striped fabric.

25 All four edges of the assembly were over-locked. Rectangular holes were cut out of alternate weft bars one each side (with the sides offset by one bar, creating the circuit as shown above) approximately 14 mm from edge and approximately 13 mm wide. Two lengths of 17 mm wide tape with tinned-copper wire floats were cut 280 mm long. One is stitched in place on each side such that the wire floats contact the weft bars. An overhang of 30 mm is placed at one end to be used for attaching the multimeter.

30

The specimens were assessed for their response to distilled water and to a 4% saline solution. The former should indicate the likely behaviour if condensation builds up in the system during use, with an alarm not desirable in this circumstance. The latter should indicate the likely behaviour when urine becomes present in the  
35 system as a result of the mattress cover leaking, with an alarm to be triggered.

Therefore, it is preferable that the sensitivity of the system to distilled water will be much lower than the sensitivity to saline.

#### Method of Test.

5

The specimen to be tested was placed on a non-absorbent bench, in an unconditioned lab. The ambient temperature was approximately 19°C for all tests. The terminals at the end of each side of the specimen were connected to a Center SE122 True RMS multimeter, set to measure the resistance of the specimen. This  
10 was connected to the serial port of a laptop computer running the SE120 Testlink data collection software. The resistance of the specimen was acquired every two seconds during the test. This data was saved in CSV form (comma separated values) which was then exported to Microsoft Excel for further analysis.

15 Two fluids were used for the testing: distilled water and a 4% w/w saline solution (i.e. sodium chloride in distilled water). There are 'recipes' for artificial urine which can be prepared using sodium chloride, potassium chloride, sodium phosphate and urea, plus traces of other chemicals (such as amino acids) but in discussion with ACDS it was decided that the response to saline would be provide sufficient  
20 information. Future testing could easily use a more realistic formulation, or samples of actual urine.

Some initial trials indicated that a total of three drops of each fluid from a disposable pipette was an appropriate volume of fluid to add to specimens of this size. It was  
25 calculated that each drop was on average 0.033 ml in volume, so the three drops was approximately 0.1 ml. This is quite a small amount of fluid, so if a useful response can be obtained from the specimens under these conditions it is likely that the system will have the required sensitivity in the final application. The fluid was dropped onto the specimen from approximately 1 cm above the fabric surface.

30

The fluid was not placed onto the specimen in one dose. Three one-drop doses were applied one minute apart. This was intended to simulate the more gradual fluid penetration that is likely to occur with a mattress cover leak.

35 Before adding the fluid, data recording was carried out for the dry specimen for 30 seconds. The first drop of fluid was added at this stage ( $t = 30$  seconds), with

another added 60 seconds after this (t = 90 seconds), and the final drop added after a further 60 seconds (t = 150 seconds). Data was collected continuously over fifteen minutes (end of test at t = 900 seconds), but one-off readings were made ten and twenty minutes after the end of recording (t = 1500 and 2100 seconds, respectively).

5

The fluid was placed directly onto a conductive stripe in the fabric. This placement should represent the slowest response that the specimen could provide, as the fluid has to traverse an entire non-conductive stripe to reach an adjacent conductive stripe and trigger a change in resistance. The fastest response could be expected if the drops were placed exactly between the conductive stripes, as only half a non-conductive stripe would need to be traversed to trigger the response in this case.

10

### Results

Each specimen was tested four times, twice with each of the fluids. The order of test was such that it was unnecessary to carry out any additional processes on the specimen after test, apart from thorough drying. The fabric was not prepared in any way before testing (such as pre-washing, solvent extraction etc.). The order of testing was as follows:

20

Distilled water 1 → Distilled water 2 → Saline 1 → Saline 2

In theory, the distilled water leaves no residue on the fabric, so any washing or rinsing after each of these tests is redundant. The second saline test is, therefore, carried out on a fabric that has a sodium chloride residue on it, but before carrying out this test it was confirmed that the resistance had increased to a high level. In the absence of moisture, the sodium chloride is non-conductive, as there is no means for ion movement (and hence conduction). If the second test involved placing the drops onto the exact same region as the previous then the effect may be equivalent to having doubled the saline solution concentration. However, each of the four tests was carried out on a different region of the specimen, with no overlap of the (previously) wetted areas.

25

30

The full results for each test on each specimen are illustrated in Figures 5 to 16. A summary of the resistance values at key times is provided in Table 1. Note that the 1500 s and 2100 s readings were not made for the final assessment as the basic pattern for these readings had been established. It is also important to note that the

35

maximum measurable resistance for the multimeter being used was 40M $\Omega$ , so readings above this limit are recorded as '> 40 M'. Where this is given as the resistance the actual resistance may be much higher – in theory (for a dry specimen with no defects) it will be in the Giga-ohm range (G $\Omega$ , 1 x 10<sup>9</sup>  $\Omega$ ).

5

Table 1. Summary of resistance changes.

Specimen	Fluid	Test No.	Resistance at time given					
			30 s	90 s	150 s	900 s	1500 s	2100 s
MLSF001	Distilled water	1	> 40 M	13.0 M	2.67 M	753 k	649 k	639 k
		2	> 40 M	> 40 M	6.29 M	5.36 M	4.94 M	4.84 M
	Saline solution	1	> 40 M	> 40 M	390 k	32.1 k	67.4 k	50.1 k
		2	9.36 M	9.67 M	9.09 M	48.8 k	---	---
MLSF002	Distilled water	1	> 40 M	33.0 M	23.7 M	1.25 M	1.28 M	1.35 M
		2	> 40 M	> 40 M	19.8 M	1.51 M	1.39 M	2.59 M
	Saline solution	1	> 40 M	546 k	217 k	87.0 k	104 k	112 k
		2	19.0 M	105 k	80.9 k	48.6 k	---	---
MLSF003	Distilled water	1	8.51 M	89.8 k	56.8 k	25.3 k	117 k	141 k
		2	> 40 M	562 k	53.8 k	75.4 k	114 k	176 k
	Saline solution	1	14.8 M	4.21 k	694 $\Omega$	2.13 k	2.08 k	2.32 k
		2	95.0 k	1.06 k	1.08 k	1.99 k	---	---

Key:

M = Mega-ohms (M $\Omega$ , 1 x 10<sup>6</sup> ohms), k = kilo-ohms (k $\Omega$ , 1 x 10<sup>3</sup> ohms).

10

15

In every case, there is a clear difference in behaviour between the different specimens and most importantly, for the two fluids used. It should be noted that the same (logarithmic) scale has been used for all graphs, so that direct comparisons can be made, and any clear differences are in fact likely to be an order of magnitude or more.

For distilled water, MLSF001 and MLSF002 appear to have similar response times, in that the resistance of each takes approximately the same length of time to start to drop after the drops of fluid are added. This is about 30-90 seconds after fluid is added (t = 60-150 s). MLSF001 seems to have a more abrupt change in resistance when it responds, which is unexpected as the narrower conductive stripe separation of MLSF002 might have been expected to make it respond more quickly. Certainly this is the case for MLSF003, which responds almost instantaneously when the first drop of fluid is added (t ≈ 40 s). For each specimen, the two tests are reasonably similar in behaviour, with roughly the same shape of curve, and resistance values involved. For MLSF001 the change in resistance is by a factor of 53 and 7 for each of the tests, for MLSF002 it is by a factor of 32 and 26 for each of the tests, and for MLSF003 it is by a factor of 340 and 530.

The magnitude of the resistance drop is much greater for the saline solution, especially for the first of the two tests on each specimen. For the second test, the lowered starting resistance means that although the final resistance is close to that of the first test, the factor by which it has reduced is lower. The response time appears to be proportional to conductive stripe spacing, with MLSF003 faster than MLSF002, which was faster than MLSF001. Only MLSF002 responded noticeably faster with saline solution than with distilled water. For MLSF001 the change in resistance is by a factor of 1200 and 190 for each of the tests, for MLSF002 it is by a factor of 460 and 390 for each of the tests, and for MLSF003 it is by a factor of 6900 and 48.

It is clear from these results and from Figures 5 to 16, that it is easy to distinguish between distilled water and saline solution, even when the specimens have not had any special preparation to ensure that they are free of potentially conductive finishes. If the average of the two distilled water tests and the first saline solution test is compared, the difference in response is nearly two orders of magnitude for MLSF001 (30 c.f. 1200) and well over one order of magnitude for MLSF002 (29 c.f. 460) and MLSF003 (435 c.f. 6900).

Since urine and other body fluids contain substantial quantities of electrolyte, they may be considered analogous to the saline solution in the above tests. This means

that the system as described could distinguish between wetting with water and wetting with body fluids such as urine.

5 In a further embodiment of the system, positive and negative tracks are provided on opposite sides of the fabric. In this case, electrical continuity between positive and negative tracks is provided as before, when wetting occurs. However, false positives do not occur as a result of wrinkles or folds in the fabric bringing positive and negative tracks together, as may possibly occur when positive and negative tracks occur on the same side of the fabric.

10

In a further embodiment of the system, a protective layer of fabric can be applied to cover the electrical tracks, to provide mechanical separation between tracks in the event of creasing or folding. This covering layer may be pervious to fluids, and so still allow electrical continuity between tracks by means of wetting.

15

In a further embodiment of the system, the conductive yarns are included in the system as a knitted fabric, rather than a woven fabric. This provides for stretchability of the material, which may be advantageous by causing less perturbation to the pressure-distributive properties of the mattress.

20

In a further embodiment, rows of staggered slits may be provided in the woven fabric so as to allow expansion of the material in a similar fashion to lattice pastry or expanded steel mesh. These slits may occur between tracks so as not to interfere with the electrical circuit. The slits would allow expansion and stretchability in the fabric, so causing less perturbation to the pressure-distributive properties.

25

In a further embodiment of the invention, soiling of the mattress core, identified as above by means of a recognisable change in electrical characteristics of the device, is immediately transmitted (by means of a radio frequency transmitter situated inside the mattress) to a remote receiver connected to a computer. This may be for example the nurses station, which records the time and location of the adverse event, so that suitable action may be taken. In this embodiment, local interrogation of the mattress is not required, nor is local memory storage within the mattress.

30

35 In a further embodiment, soiling of the mattress identified by the circuit prompts the microcontroller to effect an irreversible change in a visible indicator. The indicator

may take the form of a permanently-changed bistable liquid crystal display, visible from the outside of the mattress cover with an appropriate clear window. Alternatively the visible indicator may comprise a combination of a small heating element inside the mattress cover, and an irreversible thermochromic strip in the

5 corresponding place outside the mattress cover. Choosing an appropriate temperature threshold well above body temperature would eliminate false positives due to skin contact. Alternatively, the position of a mechanical flag can be activated irreversibly by means of a solenoid or other mechanical actuator. The position/condition of this flag may be determined by feeling through the mattress

10 cover, without opening the cover. This flag may consist of a shaped memory alloy, which regains a predetermined shape irreversibly when subjected to an electrical stimulus.

Any of these embodiments obviate the need for electronic memory storage within

15 the mattress, or for radio transmission, while still allowing inspection without opening the mattress cover, to determine whether historical leaks have occurred.

Claims

1. A mattress protector to shield a mattress or mattress core from body fluids, the protector comprising a shielding cover for the mattress or mattress core, the shielding cover having a layer that is impermeable to body fluids, and a detector within the cover or below or in an under layer of the cover, the detector being below the impermeable layer of the shielding cover, to detect body fluid that has passed into or through the cover, the fluid having penetrated the impermeable layer of the shielding cover.
- 10
2. A mattress protector as claimed in Claim 1, wherein the cover is a transparent cover for a mattress with an inter-layer or under-layer having a dye that is activated by a body fluid to provide a visual indication of presence of the body fluid.
- 15
3. A mattress protector as claimed in Claim 2, wherein the dye is not reactive to water vapour.
4. A mattress protector as claimed in Claim 3, wherein the dye is specifically reactive to one or more organic compounds in urine, and/or other body fluids.
- 20
5. A mattress protector as claimed in any preceding claim, wherein the inter-layer or under-layer is absorbent.
- 25
6. A mattress protector as claimed in any preceding claim, wherein the inter-layer or under-layer is made from a stretchable material.
7. A mattress protector as claimed in Claim 1, 5, 6 or 7, wherein the detector comprises electrically conductive material in or associated with the inter-layer or under-layer whereby the detector responds to changes in electrical conductivity to detect body fluid that has passed through the cover
- 30
8. A mattress protector as claimed in Claim 7, wherein the detector comprises electrically conductive threads or fibres.
- 35

9. A mattress protector as claimed in Claim 8, wherein the electrically conductive threads or fibres are configured in rows or a matrix over the inter-layer or under-layer.

5

10. A mattress protector as claimed in Claim 8 or 9, wherein the electrically conductive threads form the warp or weft of the inter-layer or under layer.

10

11. A mattress protector as claimed in Claim 8, which further comprises a processor which monitors the electrical conductivity between neighbouring conductive threads so that in the event of a leak of ionic (electrically conductive) fluid into or through the mattress protector, a short circuit between threads will be detected and recorded.

15

12. A mattress protector as claimed in Claim 11, wherein the processor is a microprocessor integrated with the protector and adapted to be interrogated by an external device to determine if any leak events had occurred.

20

13. A mattress protector as claimed in Claim 12, wherein the microprocessor is within or below the cover and is adapted to be interrogated by an inductive link.

14. A mattress protector as claimed in any of Claims 7 to 13, wherein positive and negative tracks are provided on opposite sides of the fabric whereby wrinkles or folds in the fabric will not bring positive and negative tracks together.

25

15. A mattress protector as claimed in any of Claims 7 to 13, wherein a protective layer of fabric is applied covering the electrical tracks, to provide mechanical separation between tracks in the event of creasing or folding, the layer being pervious to fluids.

30

16. A mattress protector as claimed in any of Claims 8 to 15, wherein the conductive threads or fibres are included in the system as a knitted fabric, rather than a woven fabric for stretchability of the material.

17. A mattress protector as claimed in any of Claims 7 to 16, wherein the protector is of a woven fabric and slits are provided in the woven fabric so as to allow expansion of the material.

5 18. A mattress protector as claimed in any of Claims 7 to 17, wherein when the detector detects body fluid that has passed through the cover a signal is substantially immediately transmitted to a remote receiver connected to a computer.

10 19. A mattress protector as claimed in Claim 18, wherein the protector has a radio frequency transmitter situated inside the mattress to transmit the signal to the receiver.

15 20. A mattress protector as claimed in Claim 18 or 19, wherein the computer is programmed to record the time and location of the event, so that suitable action may be taken.

20 21. A mattress protector as claimed in any of Claims 7 to 20, wherein when the detector detects body fluid that has passed through the cover the circuit prompts a microcontroller to effect an irreversible change in a visible indicator.

22. A mattress protector as claimed in Claim 21, wherein the visible indicator is visible from the outside of the mattress cover via an appropriate clear window.

25 23. A mattress protector as claimed in Claim 21, wherein the visible indicator comprises a combination of a small heating element inside the mattress cover, and an irreversible thermochromic strip in the corresponding place outside the mattress cover.

30 24. A mattress protector as claimed in any of Claims 7 to 23, wherein the position of a mechanical flag can be activated irreversibly by means of a solenoid or other mechanical actuator and the position/condition of this flag may be determined by feeling through the mattress cover, without opening the cover.

35 25. A mattress protector as claimed in Claim 24, wherein the flag is formed of a shaped memory alloy, which regains a predetermined shape irreversibly when subjected to an electrical stimulus.

26. A mattress protector as claimed in any preceding claim in combination with a mattress.
- 5 27. A mattress core encased in a mattress protector of any of Claims 1 to 13.
28. A mattress protector substantially as hereinbefore described with reference to the accompanying drawings.

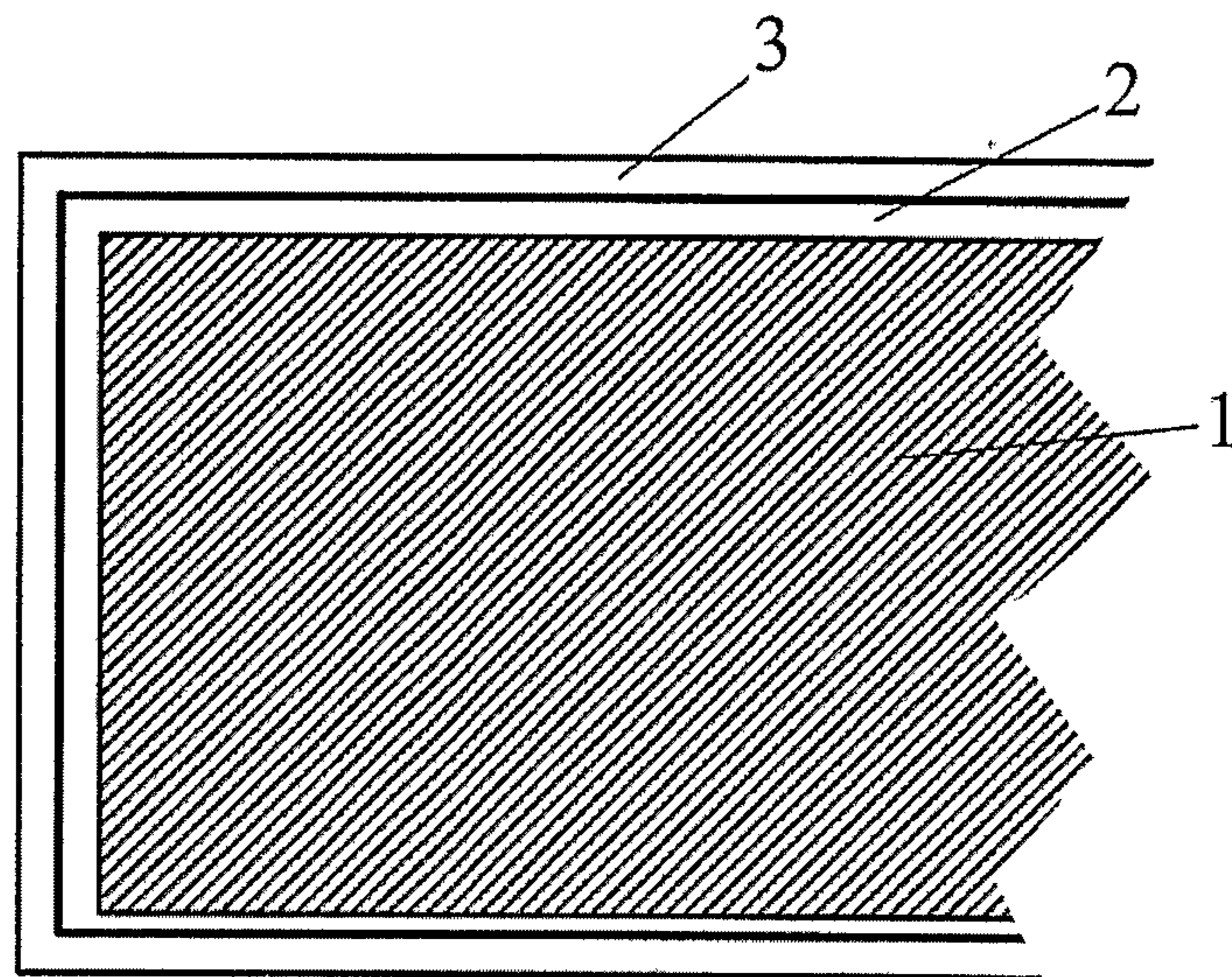

Fig. 1

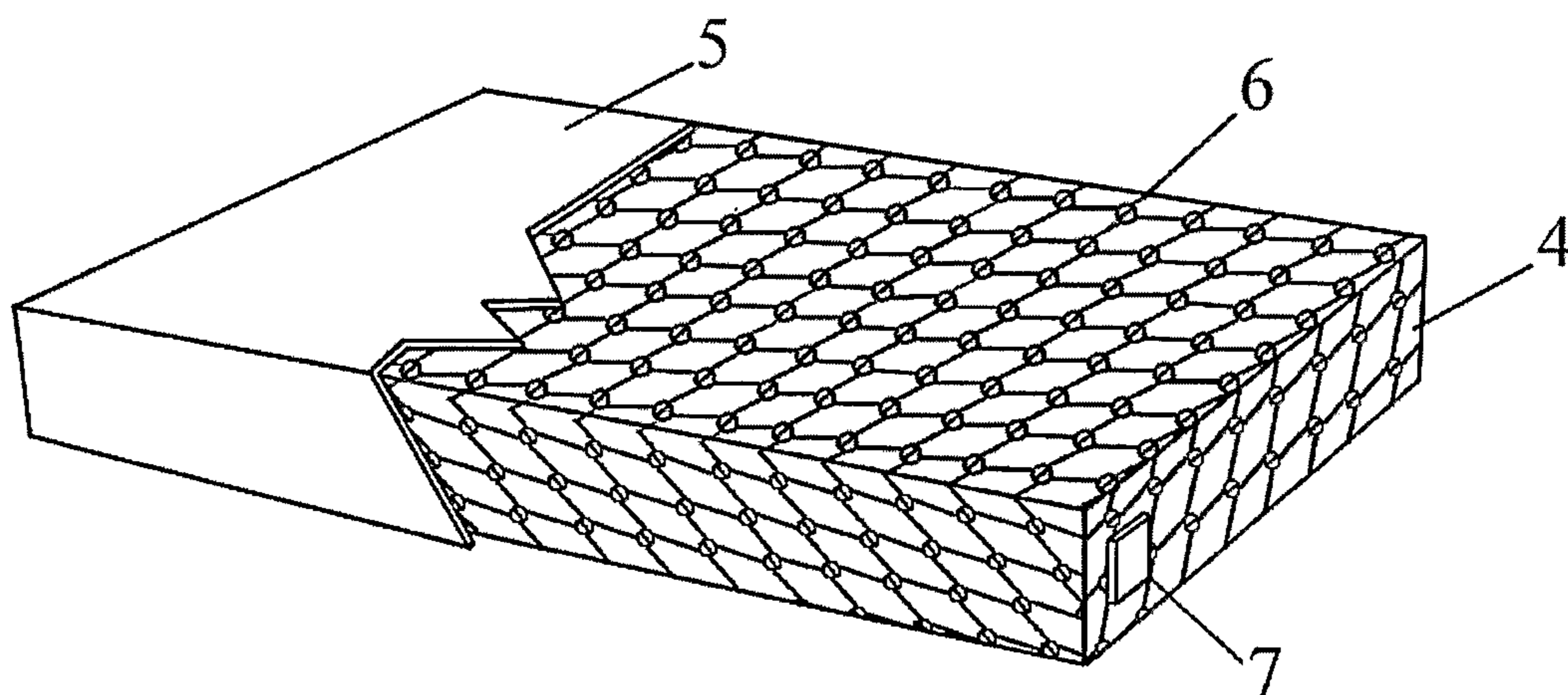

Fig. 2

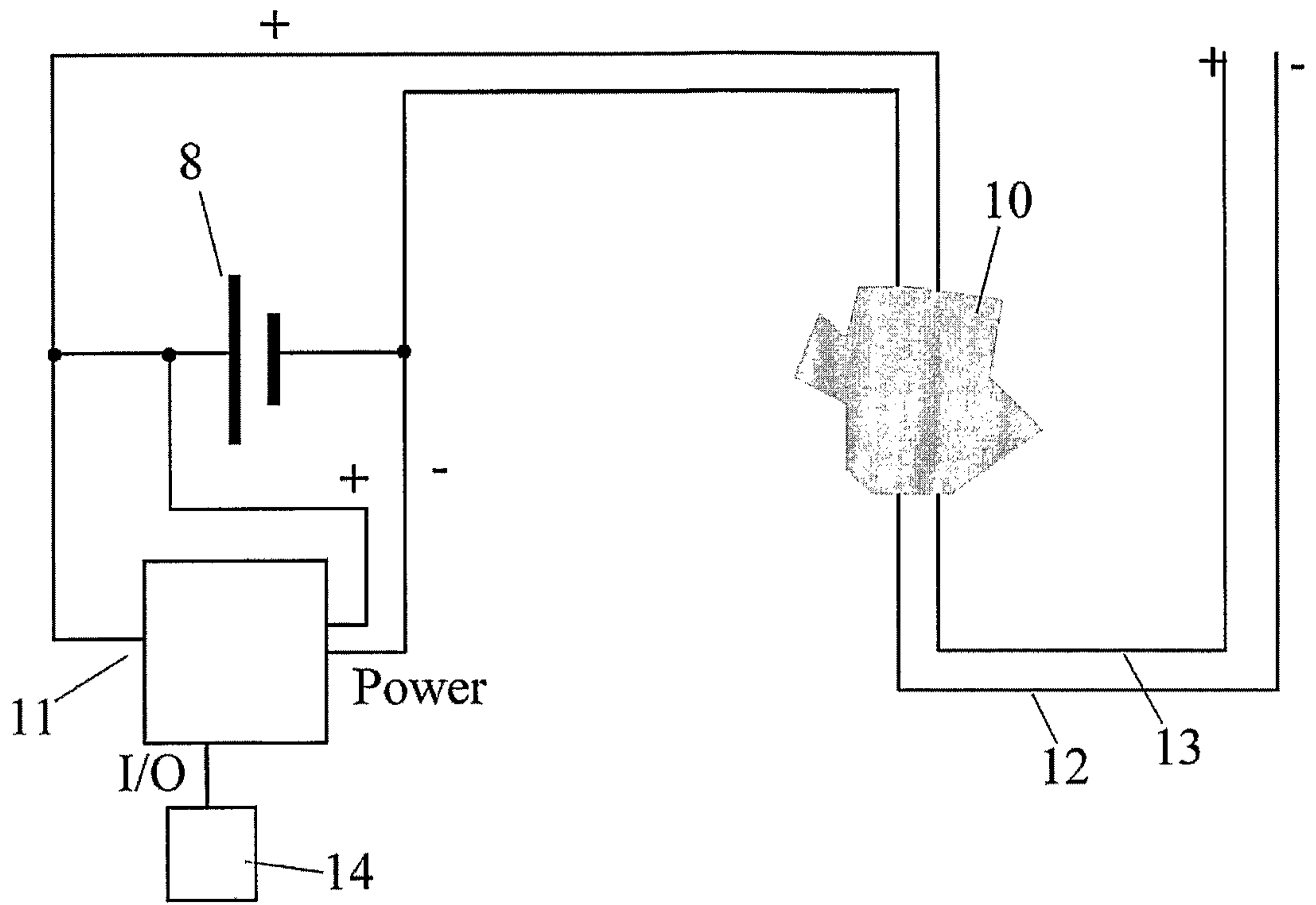

Fig. 3

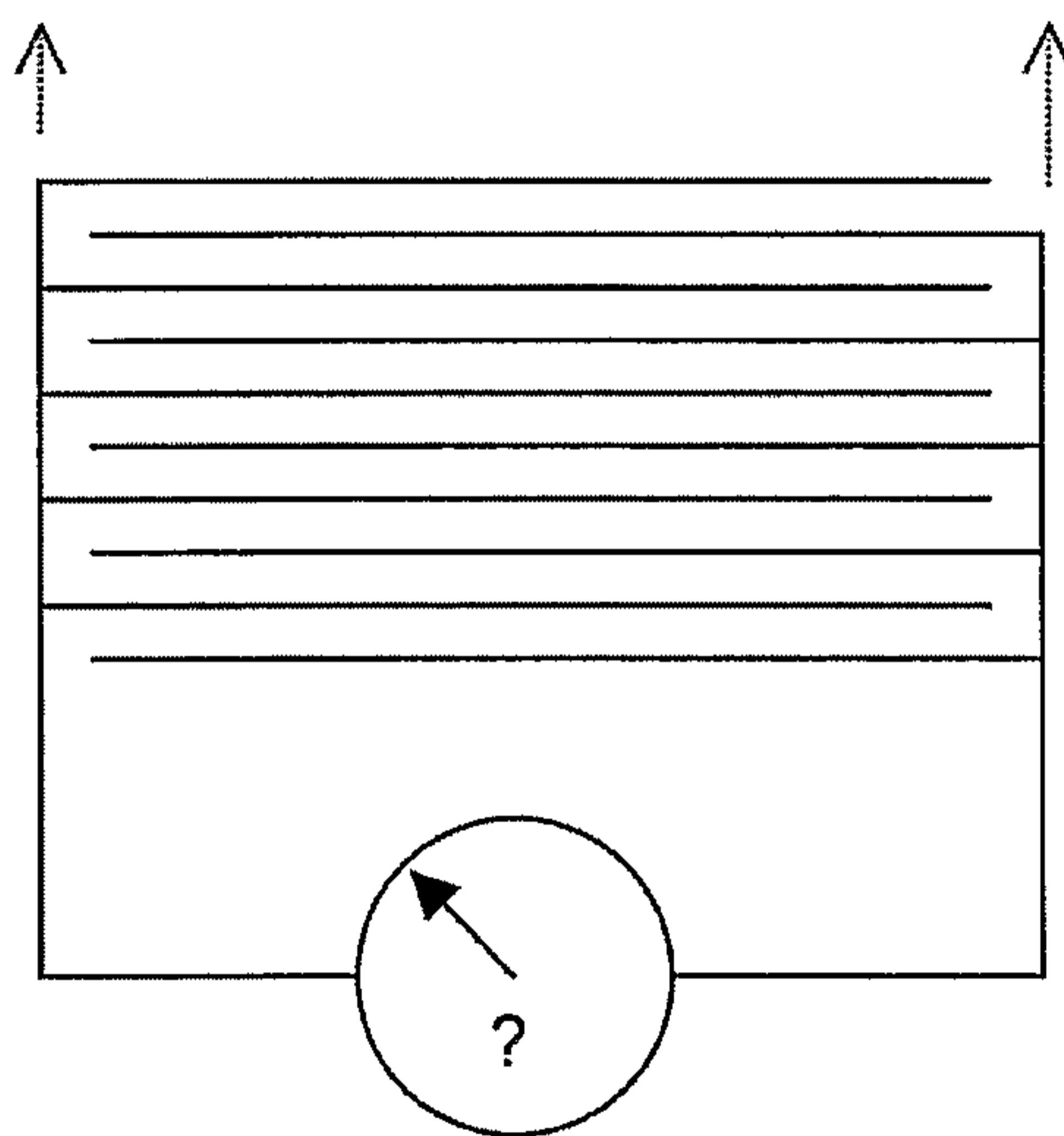

Fig. 4

3/10

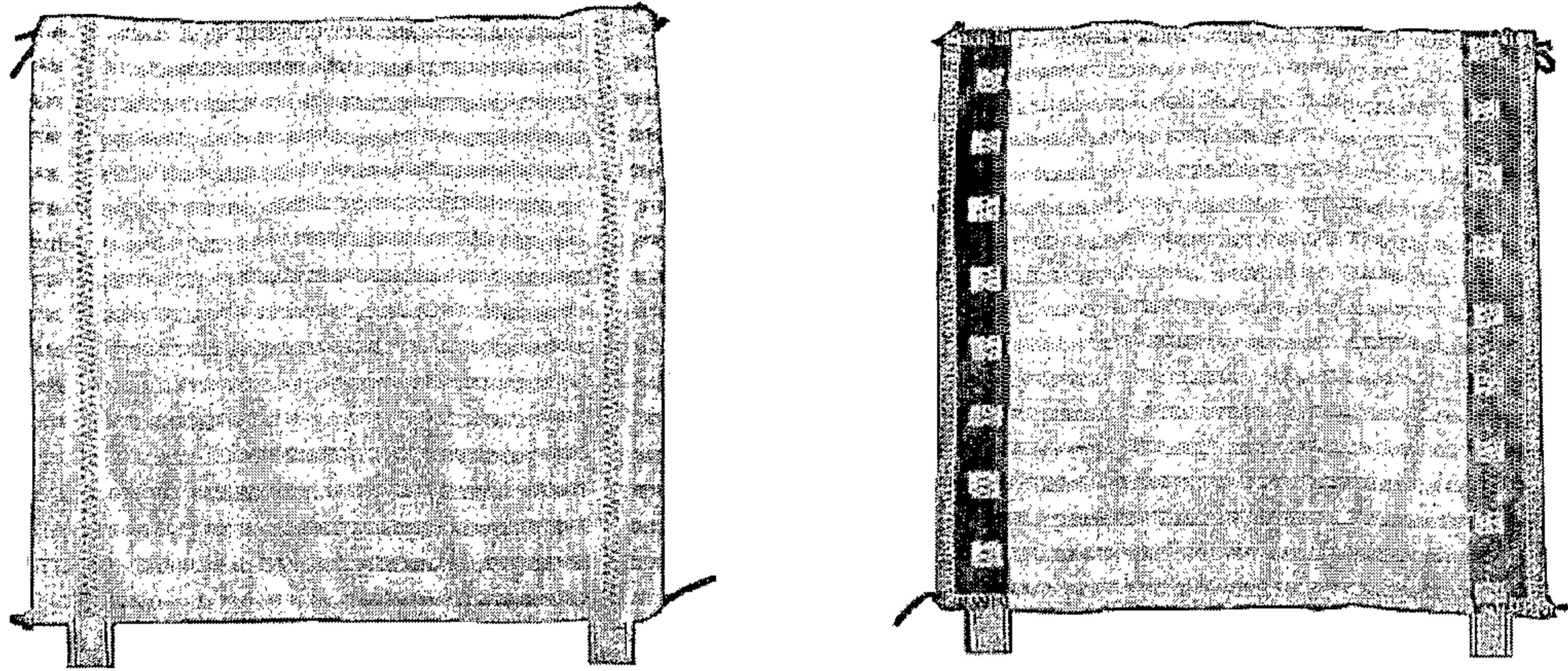

Fig. 5

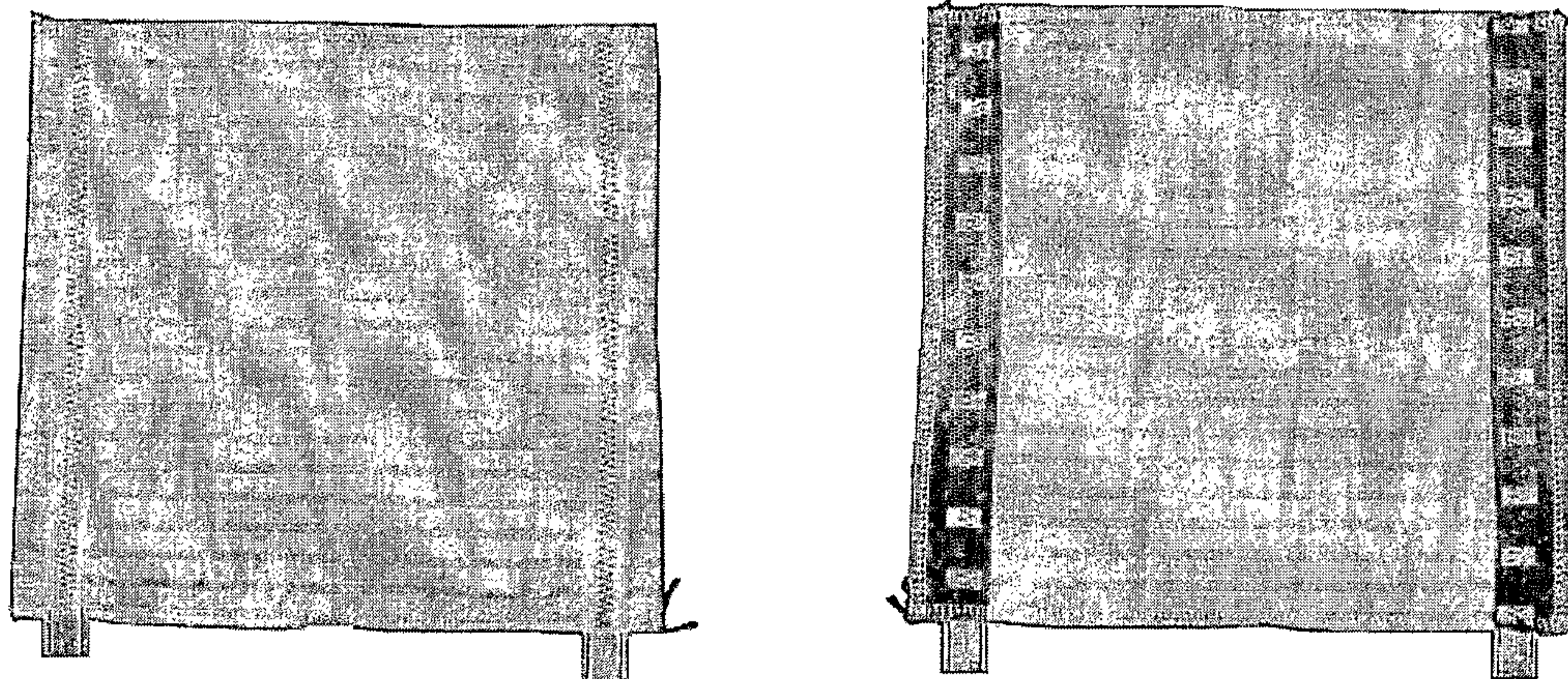

Fig. 6

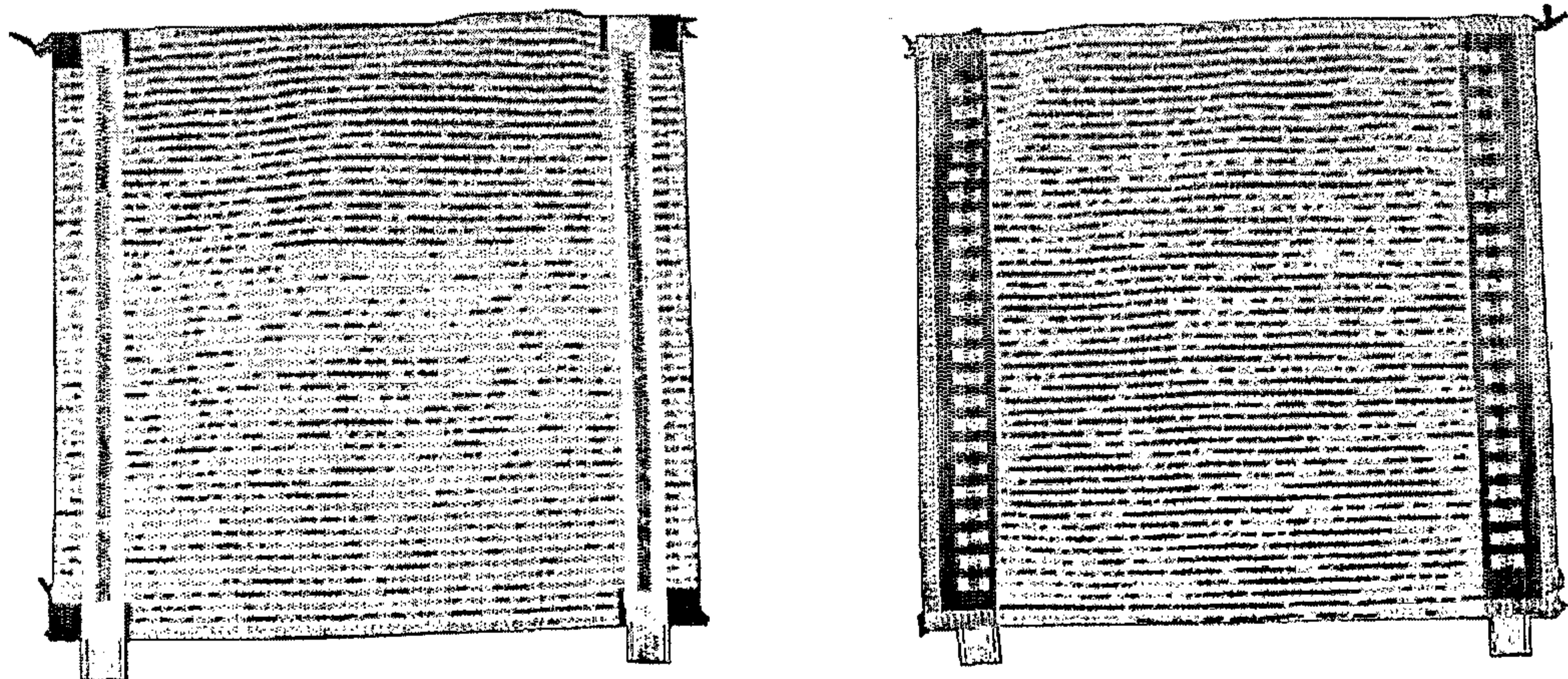

Fig. 7

4/10

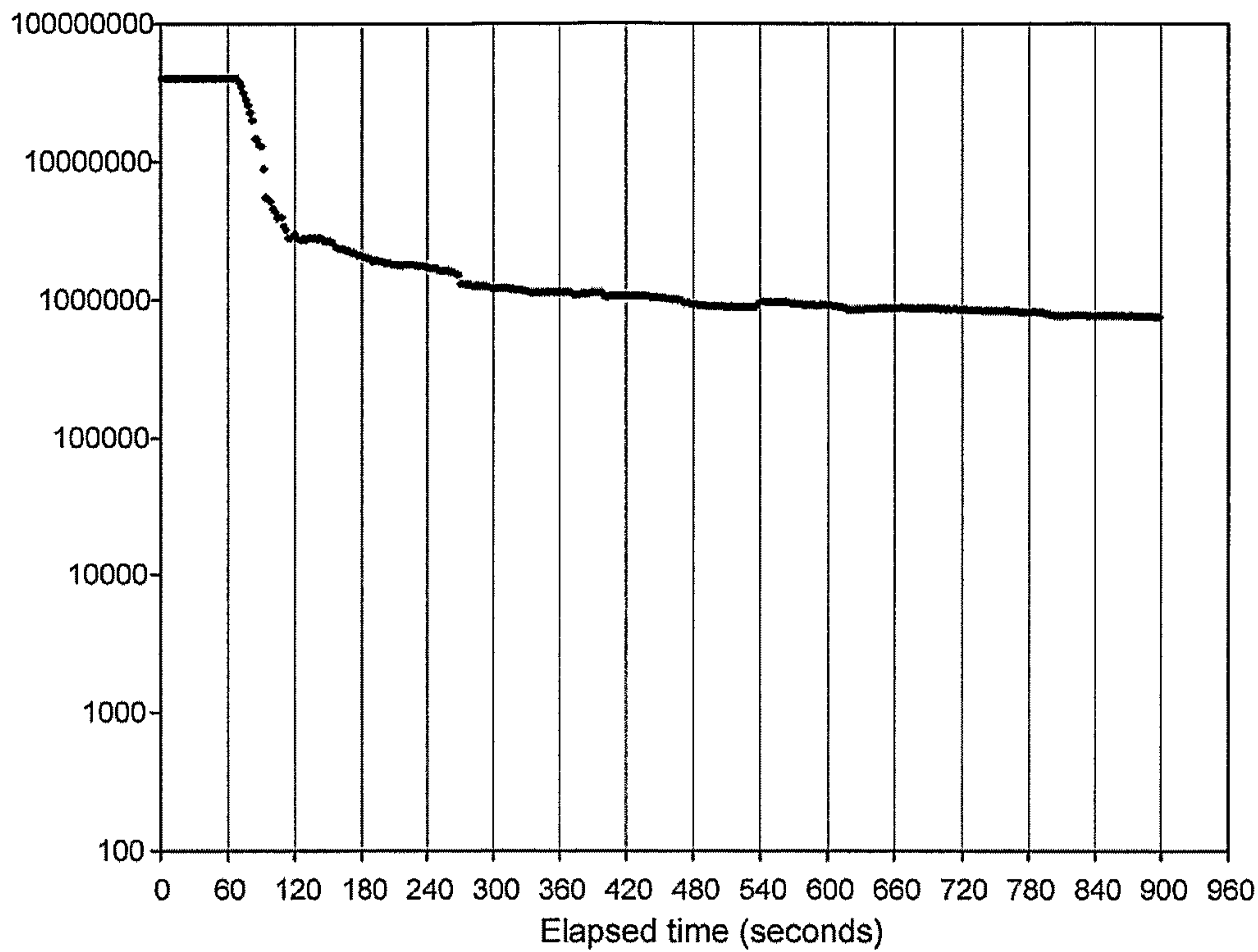

Fig. 8

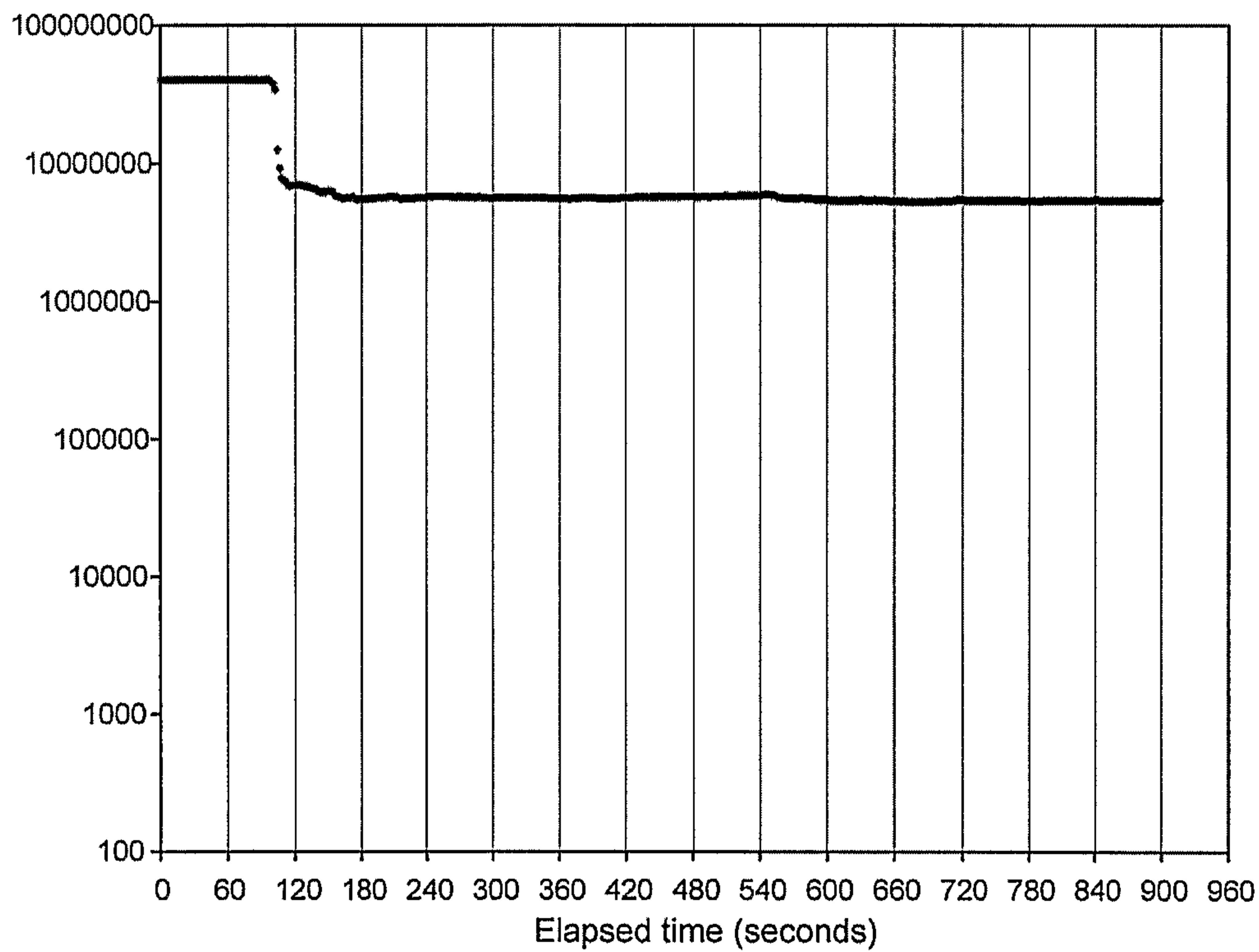

Fig. 9

5/10

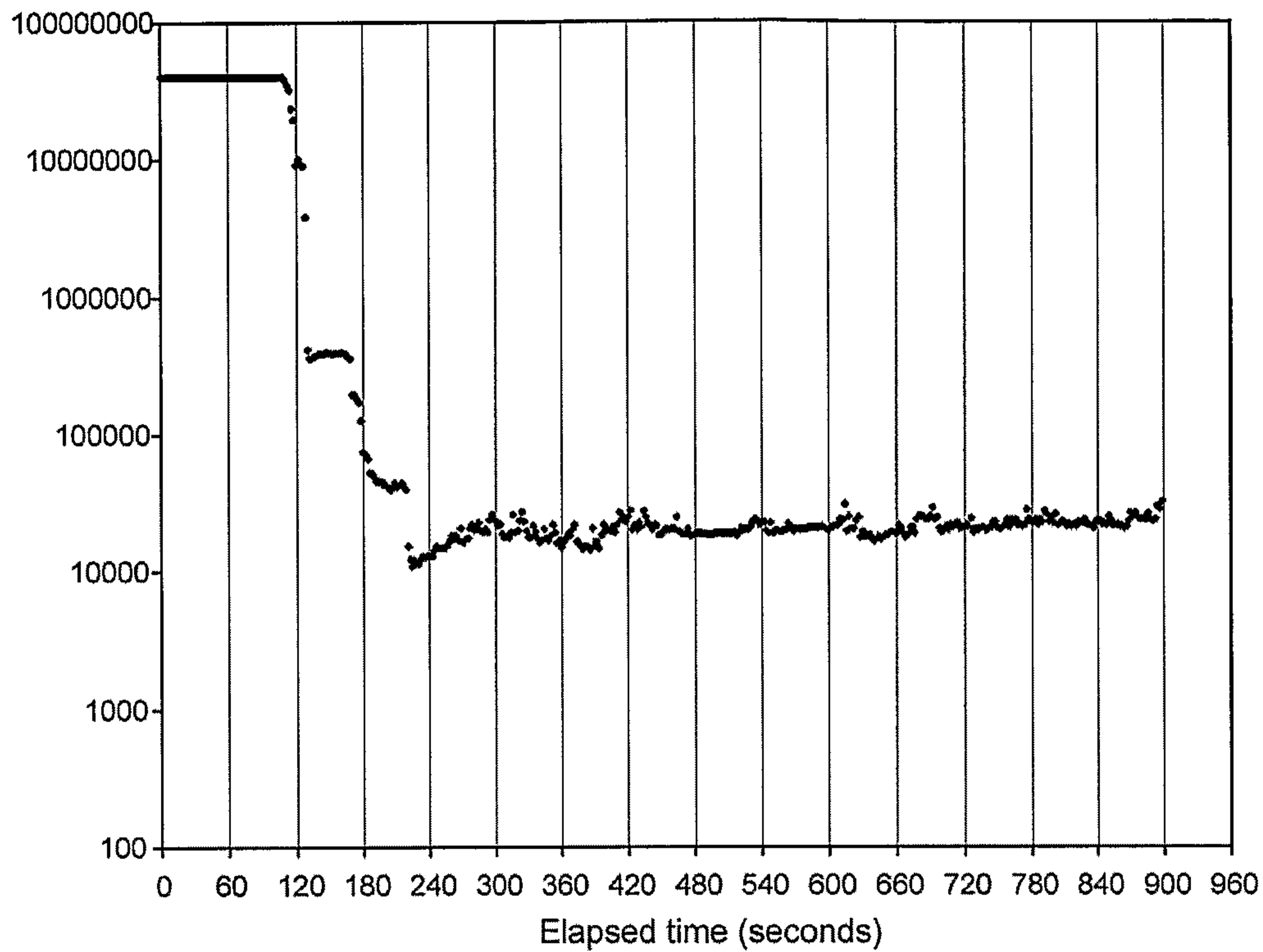

Fig. 10

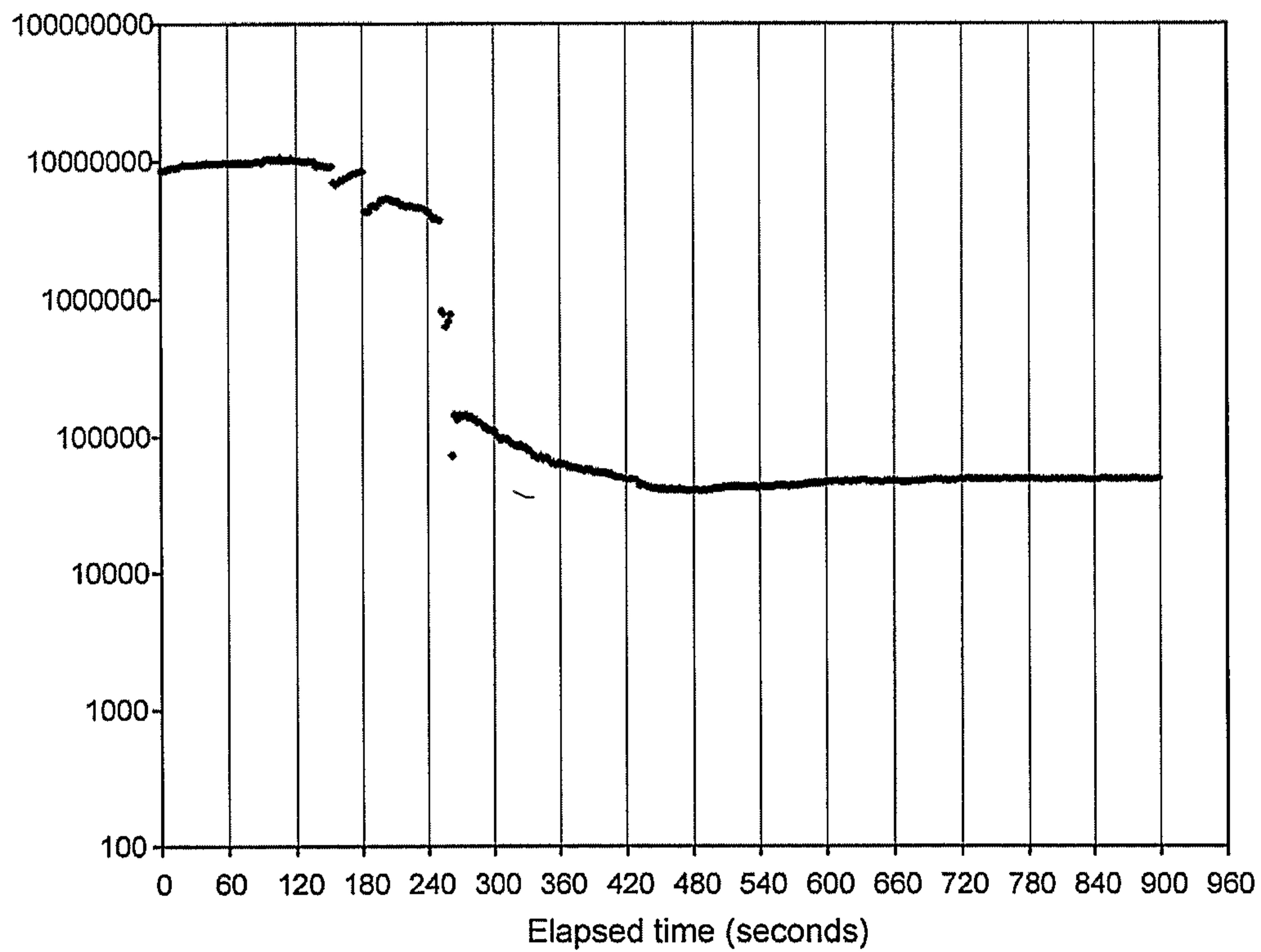

Fig. 11

6/10

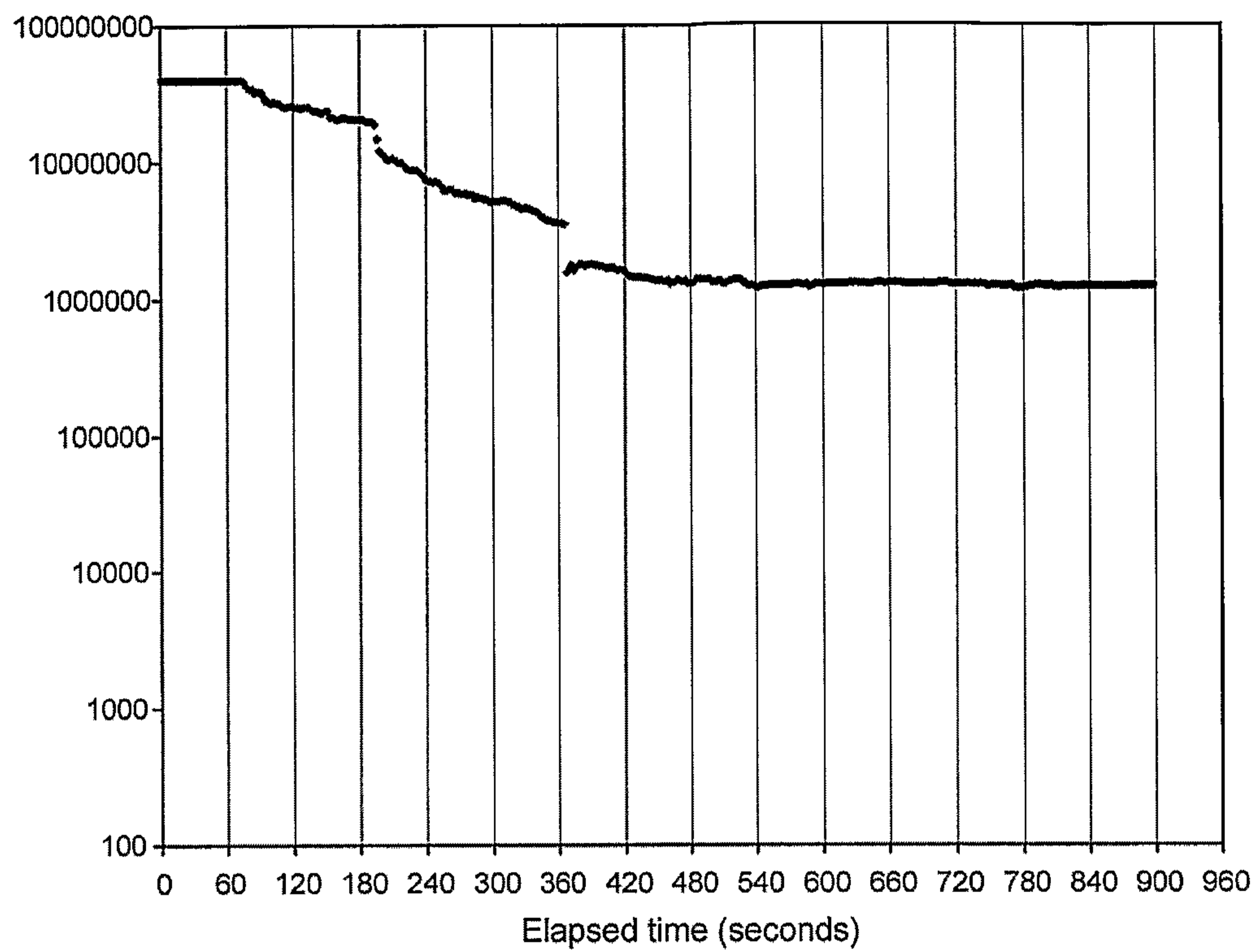

Fig. 12

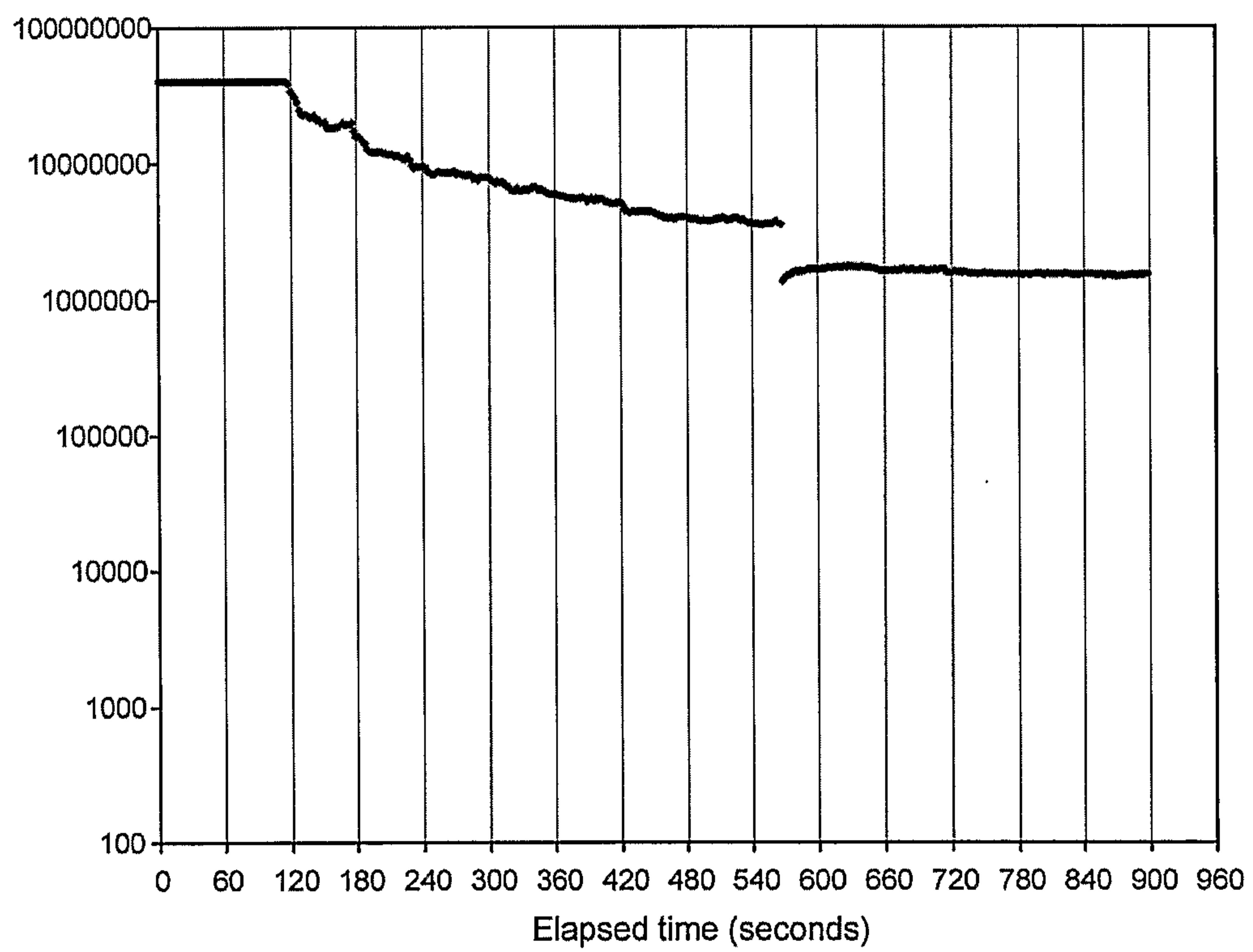

Fig. 13

7/10

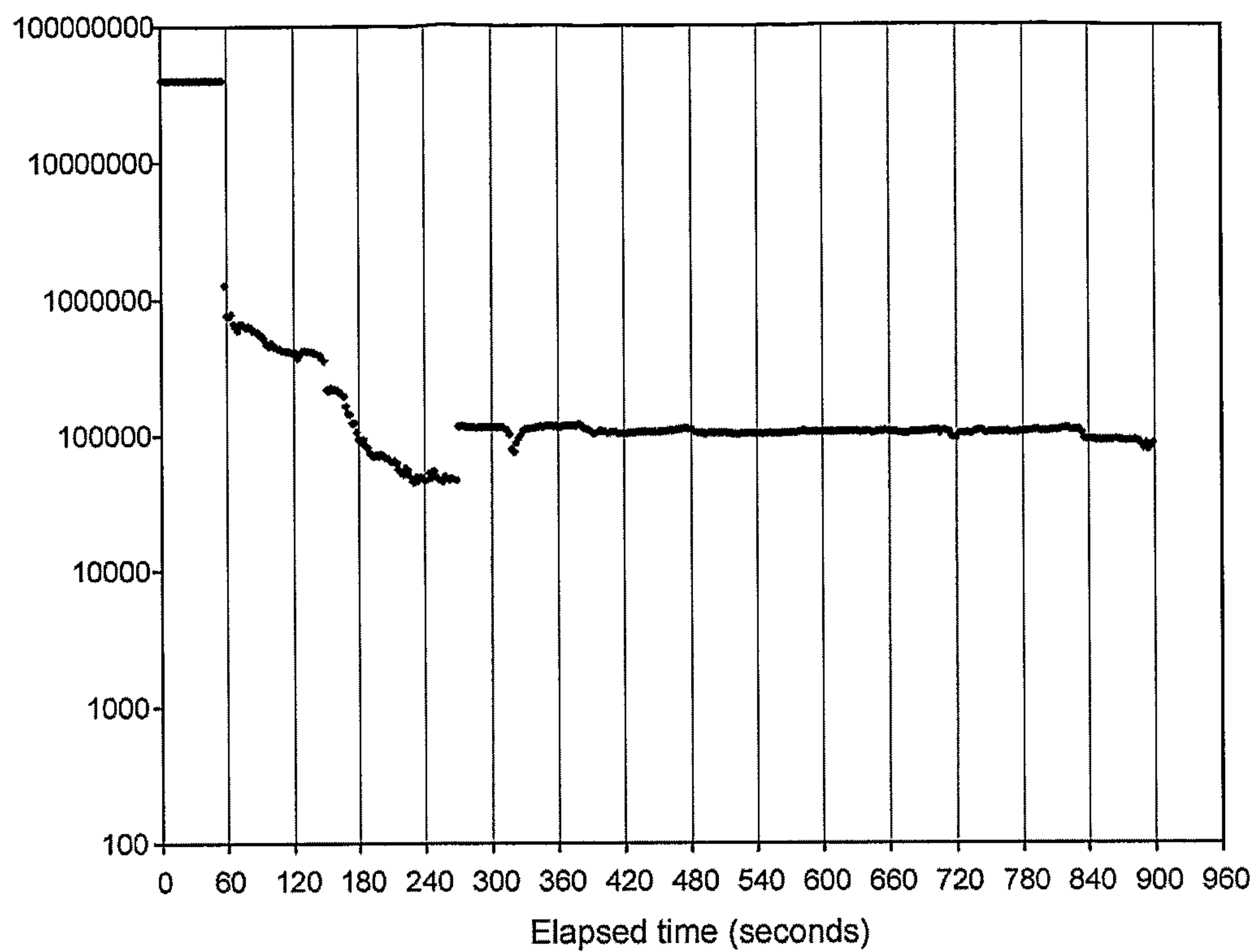

Fig. 14

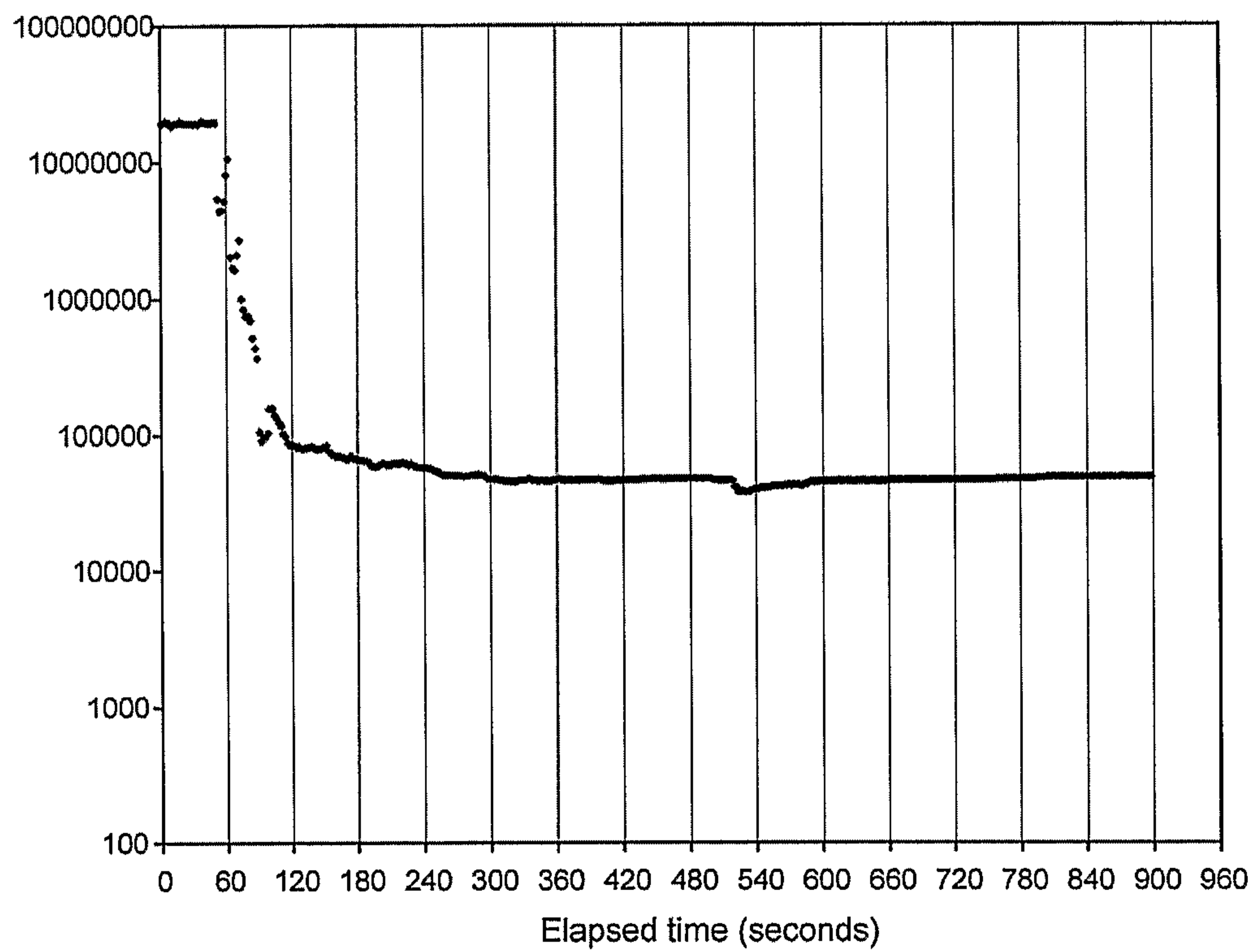

Fig. 15

8/10

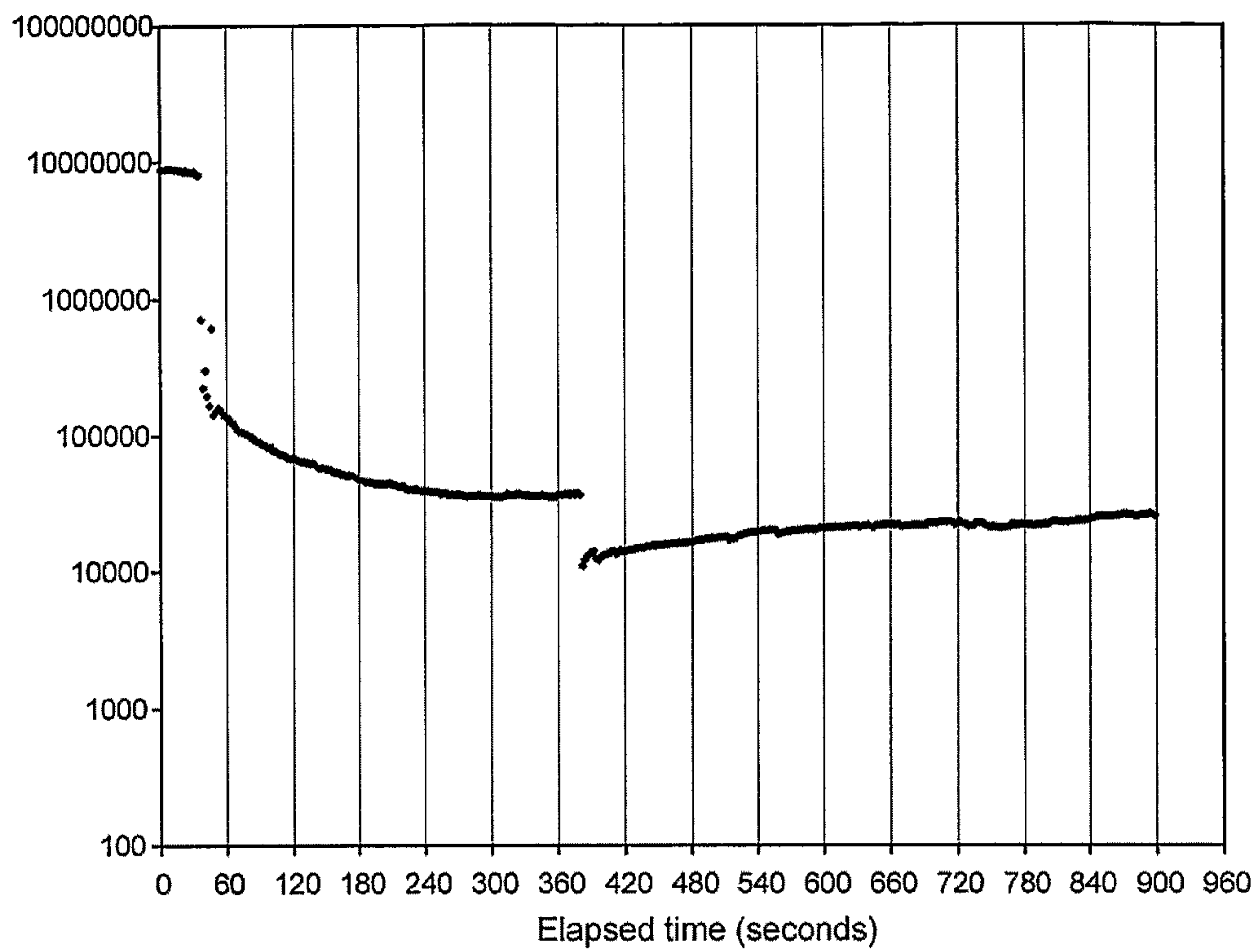

Fig. 16

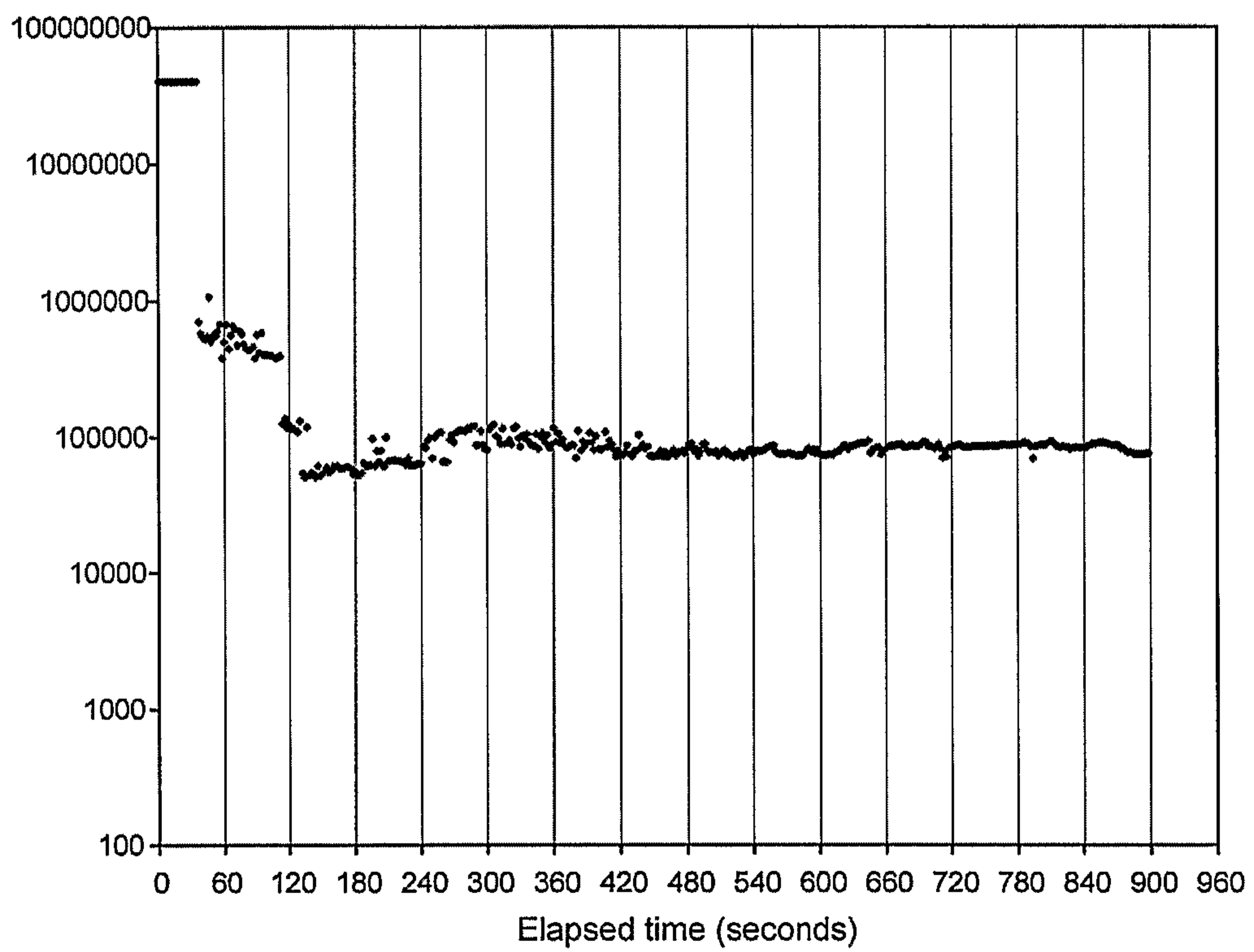

Fig. 17

9/10

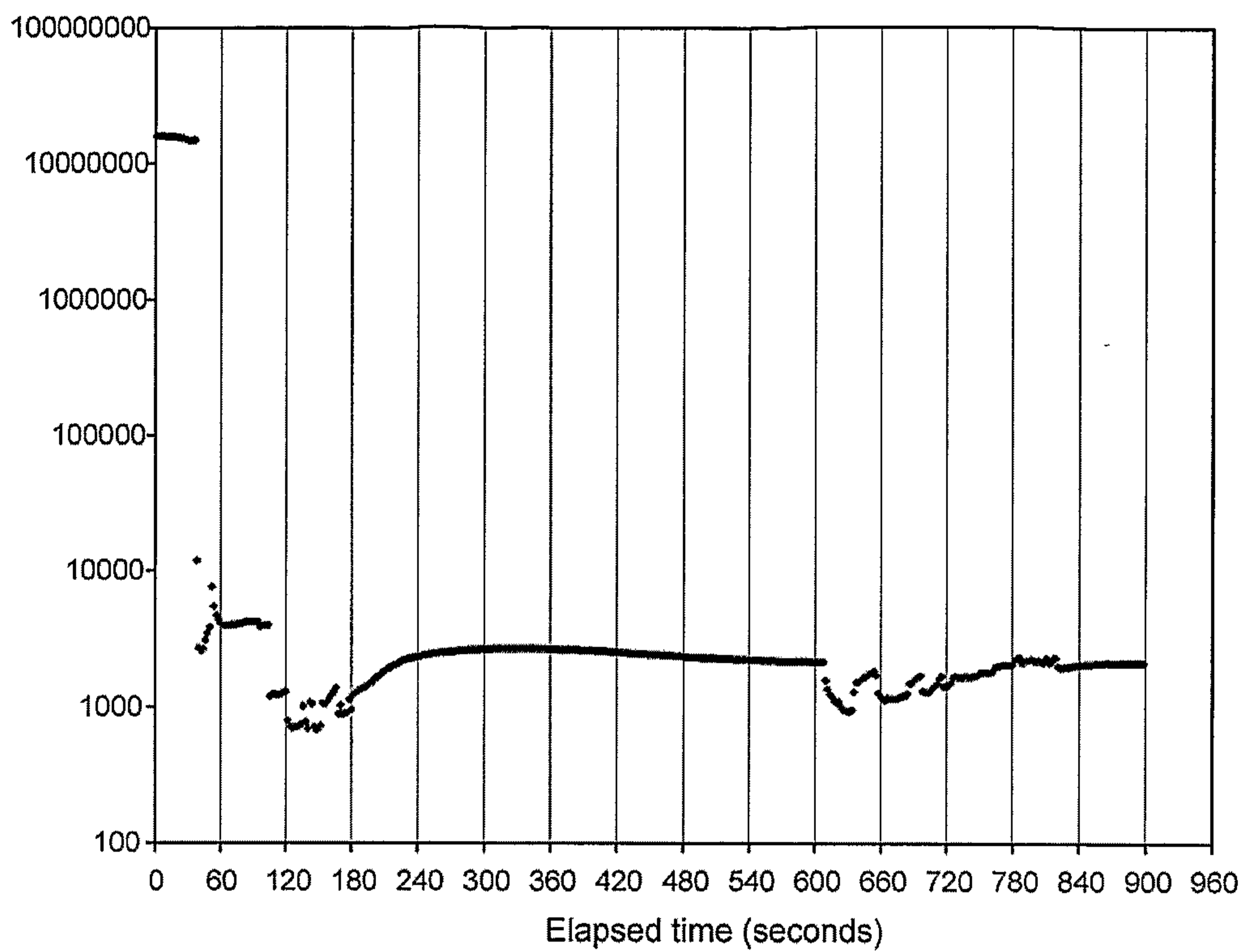

Fig. 18

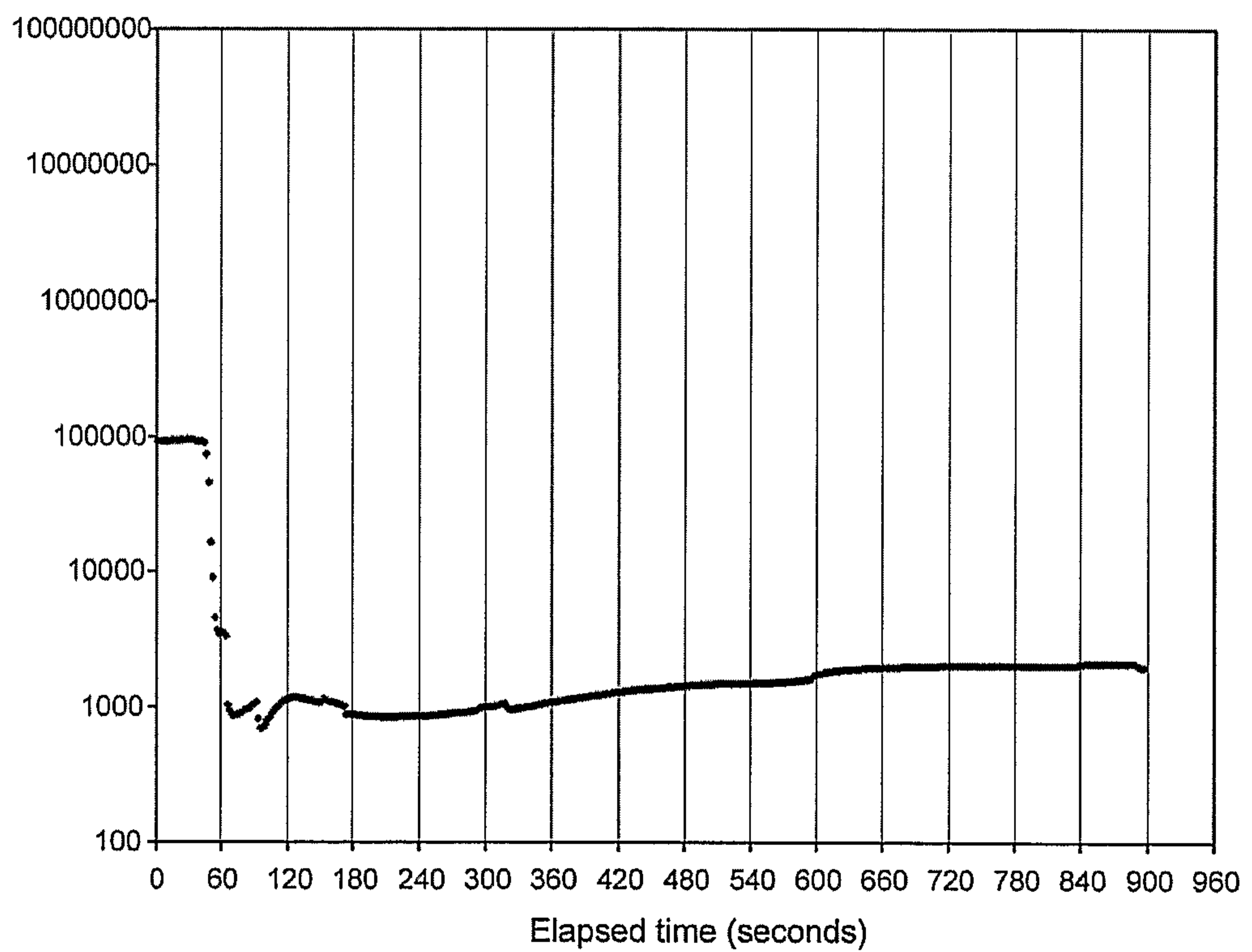

Fig. 19

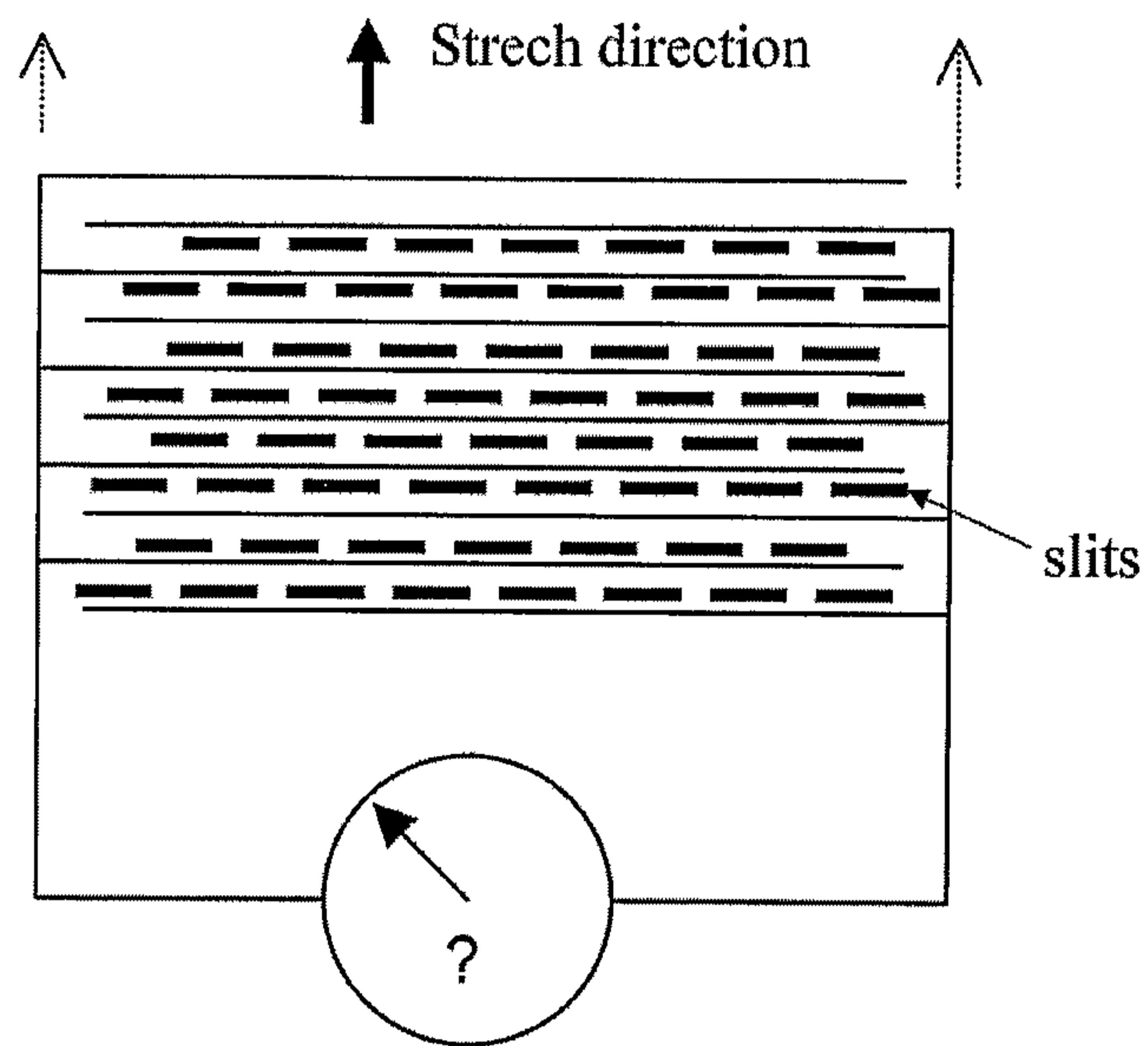

Fig. 20

