

(19)



(11)

**EP 1 962 020 A1**

(12)

**EUROPEAN PATENT APPLICATION**

(43) Date of publication:

**27.08.2008 Bulletin 2008/35**

(51) Int Cl.:

**F24C 7/08 (2006.01)**

(21) Application number: **07003636.3**

(22) Date of filing: **22.02.2007**

(84) Designated Contracting States:

**AT BE BG CH CY CZ DE DK EE ES FI FR GB GR HU IE IS IT LI LT LU LV MC NL PL PT RO SE SI SK TR**

Designated Extension States:

**AL BA HR MK RS**

• **Vetter, Joachim**

**91583 Schillingsfürst (DE)**

• **Koitzsch, Erhardt**

**91541 Rothenburg (DE)**

• **Michel, Herbert**

**91616 Neusitz (DE)**

(71) Applicant: **Electrolux Home Products Corporation N.V.**

**1930 Zaventem (BE)**

(74) Representative: **Hochmuth, Jürgen**

**AEG Hausgeräte GmbH,**

**Patente, Marken & Lizenzen**

**90327 Nürnberg (DE)**

(72) Inventors:

• **Meissner, Heiko**

**90547 Stein (DE)**

(54) **Method for fastening a functional component to a carrier element of a domestic appliance and mounting device**

(57) The invention relates to a method for fastening a functional component (1) to a carrier element (2) of a domestic appliance (3). To precisely fix the functional component to the carrier element the invention proposes the process steps: a) Applying a defined amount of adhesive (4) on a fixation area (5) of the functional component (1) or the carrier element (2); b) Positioning of the functional component (1) relatively to the carrier element

(2) in a defined position by means of an actuator (6) of a mounting device (7); c) Pressing the fixation area (5) of the functional component (1) against the carrier element (2) by means of the actuator (6) of the mounting device (7), so that the fixation area (5) of the functional component (1) or of the carrier element (2) presses against a counter area (8) of the other part (2, 1). Furthermore, the invention relates to a mounting device (7) for fastening a functional component to a carrier element.

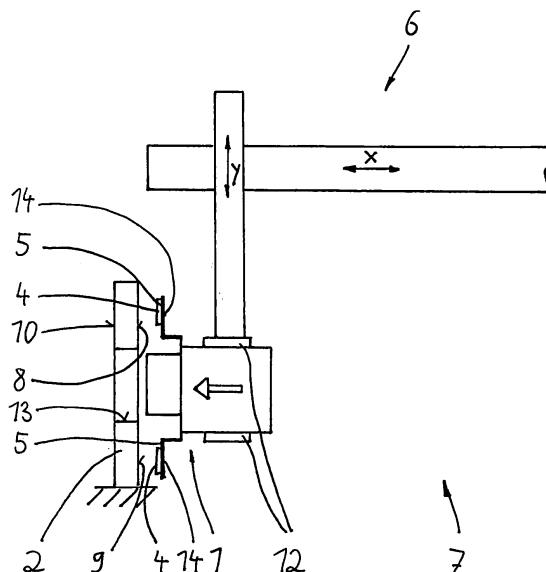

**FIG 3**

**EP 1 962 020 A1**

## Description

**[0001]** The invention relates to a method for fastening a functional component to a carrier element of a domestic appliance. Furthermore, it relates to a mounting device for fastening a functional component to a carrier element.

**[0002]** During the assembly process of a domestic appliance, like e. g. a kitchen oven, a washing machine and a dryer, a carrier element of the appliance like e. g. a panel has to be equipped with a functional element which has to be fixed at the carrier element.

**[0003]** The functional element can be e. g. an electronic part of the domestic appliance, an operational device of the appliance or a fastening element.

**[0004]** For fixing the functional element at the carrier element different solutions are known in the art. DE 85 35 431 U1 shows the fixation of a functional component at a carrier element by a specific design by using journals and bushings. With this the functional component can be detachably connected with the carrier element.

**[0005]** Another mechanical solution to fix a functional component to a carrier element shows DE 86 23 803 U1. Here an elastic element is employed which is connected with the functional element and which snaps into an undercut in the carrier element.

**[0006]** Other solutions to connect a functional component with a carrier element are shown and described in DE 103 09 516 B3, in DE 103 49 592 A1, in DE 199 17 191 C2, in DE 195 04 471 B4.

**[0007]** In some cases the use of an adhesive film is suggested to fix parts to another, like EP 1 639 935 A2 discloses. A similar solution shows EP 1 045 300 B1.

**[0008]** Special techniques for allocating a functional element at a carrier element are shown in DE 103 37 441 A1, in DE 101 57 221 A1, in DE 103 07 536 A1 and in DE 196 45 678 C2.

**[0009]** The use of a mechanical connection between the functional element and the carrier element is quite complex and thus costly.

**[0010]** The use of an adhesive is suggested in connection with an adhesive film. This solution demands a quite huge demand concerning the handling; it is thus very problematic to automating the mounting procedure.

**[0011]** Therefore, it is an object of the invention to improve the pre-known possibilities to fix a functional component at a carrier element. Specifically, it should become possible that the fixation can be established with low costs but in a very precise way. Furthermore, it should be possible to automate the assembly process without big investments.

**[0012]** The solution of this object according to the invention is with respect to the method for fastening a functional component to a carrier element characterized in that the method comprises the steps of:

a) Applying a defined amount of adhesive on a fixation area of the functional component or the carrier element;

b) Positioning of the functional component relatively to the carrier element in a defined position by means of an actuator of a mounting device;

c) Pressing the fixation area of the functional component against the carrier element by means of the actuator of the mounting device, so that the fixation area of the functional component or of the carrier element presses against a counter area of the other part.

**[0013]** The adhesive can thus be applied in an economical way and only in those parts of the fixation area where it is really needed. The process can be automated in an easy way.

**[0014]** Preferably, before above step a) a cleaning process of the fixation area and/or of the counter area is carried out. Also, it is possible that before above step a) a primer is applied to the fixation area and/or to the counter area.

**[0015]** The functional component is preferably positioned according to above step b) at a reverse side of the carrier element-being turned away from a front wall of the carrier element. Alternatively, it is also possible that the functional component is positioned at a front wall of the carrier element.

**[0016]** The functional component can be a retainer or carrier for an electronic part of the domestic appliance. It can also be an operation device of the domestic appliance. Furthermore, an example for a carrier element is a fastening element of the domestic appliance.

**[0017]** The carrier element can be a panel of the domestic appliance. It can have a vertical orientation during its intentional use.

**[0018]** The domestic appliance is preferably a kitchen oven, a washing machine or a dryer. Of course it can also be any other kind of domestic appliances.

**[0019]** The mounting device for fastening the functional component to the carrier element is characterized in that it comprises: means for applying a defined amount of adhesive on a fixation area of the functional component or of the carrier element and an actuator for positioning the functional component relatively to the carrier element in a defined position and for pressing a fixation area of the functional component against the carrier element.

**[0020]** By this design a perfect positioning of the functional component relatively to the carrier element becomes possible. Preferably, the actuator is designed to position a tip or grip portion of it at a defined point of a cartesian coordinate system.

**[0021]** By the suggested method and the mounting device it becomes possible to fix the functional element and the carrier element in a very economical way. A suitable adhesive is used which is known in the art as such.

**[0022]** In the drawings an embodiment of the invention is depicted.

FIG 1 shows a schematically side view - partially bro-

- ken - of a domestic appliance in the form of a domestic kitchen oven,
- FIG 2 shows a perspective view of a part of a mounting device, i. e. of means for applying adhesive and a functional component,
- FIG 3 shows schematically a side view of the mounting device with an actuator,
- FIG 4 shows a perspective view of a part of a carrier element, where the front wall is shown and
- FIG 5 shows a perspective view of a part of the carrier element according to FIG 4, where the opposite side, i. e. the reverse side is shown.

**[0023]** FIG 1 shows a domestic appliance 3 which is a domestic oven for a kitchen. The domestic appliance 3 has - as can be seen in the depicted partly broken view - a carrier element 2 with a front wall 10. The carrier element 2 has an aperture 13 through which a part of a functional component 1 protrudes. The functional component 1 is fixed at the reverse side 9 of the carrier element 2. Therefore, the functional component 1 has a holding section 14 with a fixation area 5. The fixation area 5 contacts in the mounted state of the domestic appliance a counter area 8 of the carrier element 2.

**[0024]** To fix the functional component 1 to the carrier element 2 a method is employed as described above.

**[0025]** A first method step is depicted in FIG 2. Here the functional component 1 is shown which is held in position by not depicted means. An adhesive 4 is applied to the fixation areas 5 of the functional component 1. In the embodiment of FIG 2 this is done by means 11 for applying adhesive which are part of a-mounting device 7.

**[0026]** As shown in FIG 2 in a schematically way only those means 11 have a nozzle 15 by which a defined amount of adhesive can be expelled. The nozzle 15 is arranged at a - not depicted - actuator which moves the nozzle 15 precisely within a cartesian coordinate system with the coordinates x and y to exactly apply a desired amount of adhesive on the fixation area 5. Of course, a motion can be executed in the third direction in space, if necessary.

**[0027]** After the adhesive 4 is applied the functional component 1 is gripped by a tip or grip.portion 12 of the mounting device 7 as shown in FIG 3. The functional component 1 is thus precisely brought into the correct position relatively to the carrier element 2 which is positioned stationary. The grip portion 12 is moved within cartesian coordinates x, y (and of course also in z-direction which is perpendicular to the plane of FIG 3) by an actuator 6.

**[0028]** So, the functional component 1 can be positioned exactly to the carrier element 2.

**[0029]** After this is done the functional component 1 is pressed in the direction of the arrow in FIG 3 onto the carrier element 2, i. e. the fixation area 5 - which is supplied with the adhesive 4 - is pressed on the counter area 8 of the carrier element 2.

**[0030]** The mounted state of the functional compo-

nent-1 with the carrier element 2 is shown in FIG 4 and FIG 5 from two different lines of vision. In FIG 4 the front wall 10 is depicted. A knob 16 of the functional component 1 is shown which protrudes through the aperture 13 in the carrier element 2. In FIG 5 the carrier element 2 with the functional component 1 is shown, seen from the reverse side 9 of the carrier element 2.

**[0031]** The functional element can be any possible part which is necessary in a domestic appliance.

10 **[0032]** The automatization of the assembly process is possible in a very easy way as the actuator for moving the nozzle 15 as well as the actuator 6 can have NC-axes by which any-position can be reached with high precision.

15 **[0033]** It is possible to combine the described process with further activities. E. g. a cleaning process can be carried out before the adhesive 4 is applied.

**[0034]** Also a primer can be applied before the adhesive is brought on the fixation area 5.

20 **[0035]** The carrier element 2 can be of any suitable material. It can be made from sheet metal, stainless steel, light metal, glass or plastic. It can be enamelled or painted.

25 **[0036]** The carrier element in the form of a panel can have a printing.

**[0037]** With the suggested solution and the proposed method and device it becomes possible that a technique of connection can be employed which was not possible before. Specifically, the required space for the connection is less compared with a mechanical solution. Consequently, solutions become possible which demand lesser space.

### Reference Numerals

- 35 **[0038]**
- |      |                             |
|------|-----------------------------|
| 1    | Functional component        |
| 2    | Carrier element             |
| 3    | Domestic appliance          |
| 4    | Adhesive                    |
| 5    | Fixation area               |
| 6    | Actuator                    |
| 7    | Mounting device             |
| 8    | Counter area                |
| 9    | Reverse side                |
| 10   | Front wall                  |
| 11   | Means for applying adhesive |
| 12   | Tip / Grip portion          |
| 13   | Aperture                    |
| 14   | Holding section             |
| 15   | Nozzle                      |
| 16   | Knob                        |
| 55 x | x-axis                      |
| y    | y-axis                      |

## Claims

1. Method for fastening a functional component (1) to a carrier element (2) of a domestic appliance (3), **characterized in that** the method comprises the steps of:
  - a) Applying a defined amount of adhesive (4) on a fixation area (5) of the functional component (1) or the carrier element (2);
  - b) Positioning of the functional component (1) relatively to the carrier element (2) in a defined position by means of an actuator (6) of a mounting device (7);
  - c) Pressing the fixation area (5) of the functional component (1) against the carrier element (2) by means of the actuator (6) of the mounting device (7), so that the fixation area (5) of the functional component (1) or of the carrier element (2) presses against a counter area (8) of the other part (2, 1).
2. Method according to claim 1, **characterized in that** before step a) according to claim 1 a cleaning process of the fixation area (5) and/or of the counter area (8) is carried out.
3. Method according to claim 1, **characterized in that** before step a) according to claim 1 a primer is applied to the fixation area (5) and/or to the counter area (8).
4. Method according to at least one of claims 1 till 3, **characterized in that** the functional component (1) is positioned according to step b) of claim 1 at a reverse side (9) of the carrier element (2) being turned away from a front wall (10) of the carrier element (2).
5. Method according to at least one of claims 1 till 3, **characterized in that** the functional component (1) is positioned according to step b) of claim 1 at a front wall (10) of the carrier element (2).
6. Method according to at least one of claims 1 till 5, **characterized in that** the functional component (1) is a retainer or carrier for an electronic part of the domestic appliance (3).
7. Method according to at least one of claims 1 till 5, **characterized in that** the functional component (1) is an operation device of the domestic appliance (3).
8. Method according to at least one of claims 1 till 5, **characterized in that** the functional component (1) is a fastening element of the domestic appliance (3).
9. Method according to at least one of claims 1 till 8, **characterized in that** the carrier element (2) is a panel of the domestic appliance (3).
10. Method according to at least one of claims 1 till 9, **characterized in that** the carrier element (2) has a vertical orientation during its intentional use.
11. Method according to at least one of claims 1 till 10, **characterized in that** the domestic appliance (3) is a kitchen oven.
12. Method according to at least one of claims 1 till 10; **characterized in that** the domestic appliance (3) is a washing machine.
13. Method according to at least one of claims 1 till 10, **characterized in that** the domestic appliance (3) is a dryer.
14. Mounting device (7) for fastening a functional component (1) to a carrier element (2) of a domestic appliance (3), especially for performing the method according to at least one of claims 1 till 13, **characterized in that** the device (7) comprises:
  - means (11) for applying a defined amount of adhesive (4) on a fixation area (5) of the functional component (1) or of the carrier element (2) and an actuator (6) for positioning the functional component (1) relatively to the carrier element (2) in a defined position and for pressing a fixation area (5) of the functional component (1) against the carrier element (2) .
15. Device according to claim 14, **characterized in that** the actuator (6) is designed to position a tip or grip portion (12) of it at a defined point of a cartesian coordinate system.



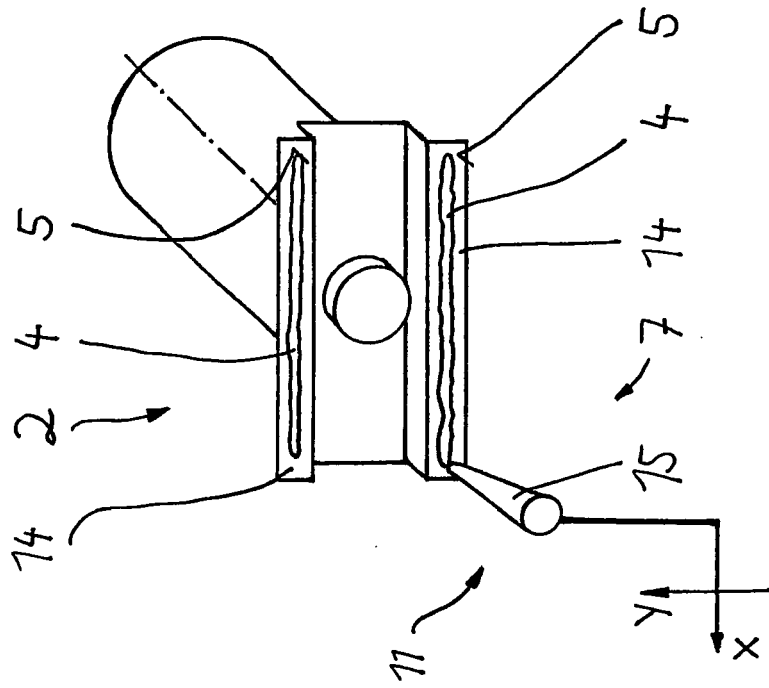

FIG 2

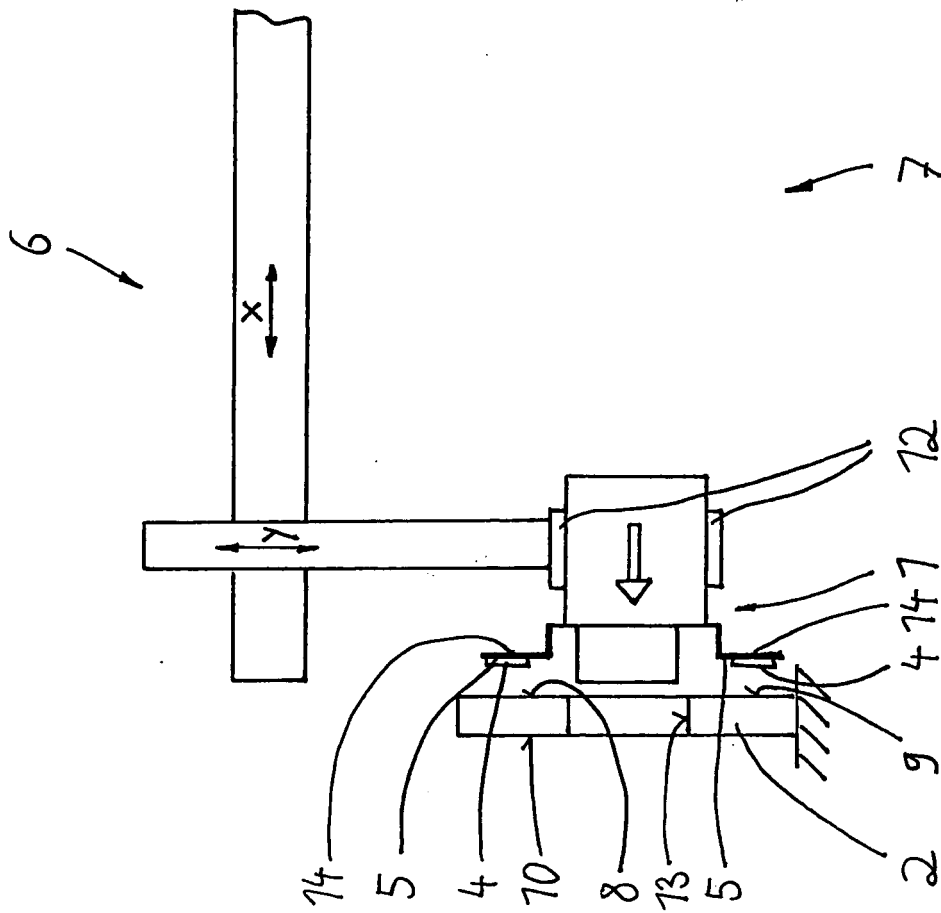

FIG 3

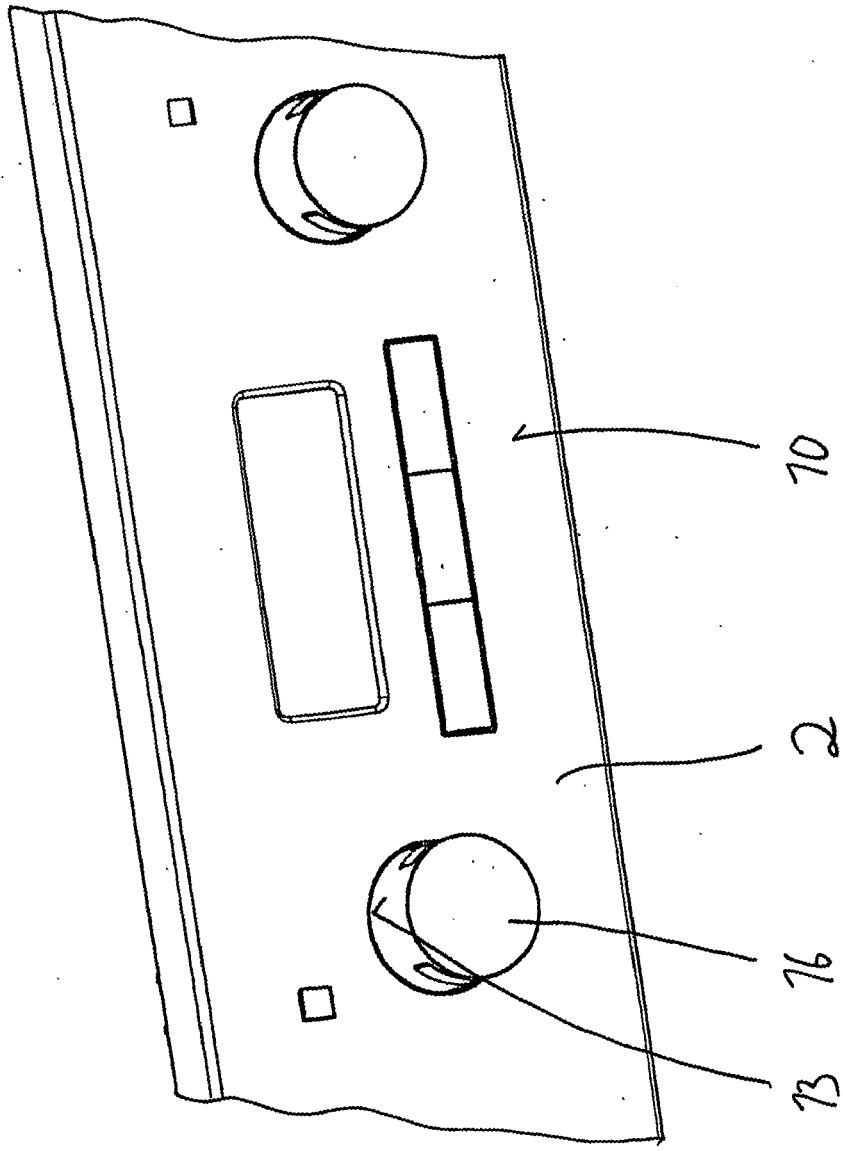

FIG 4

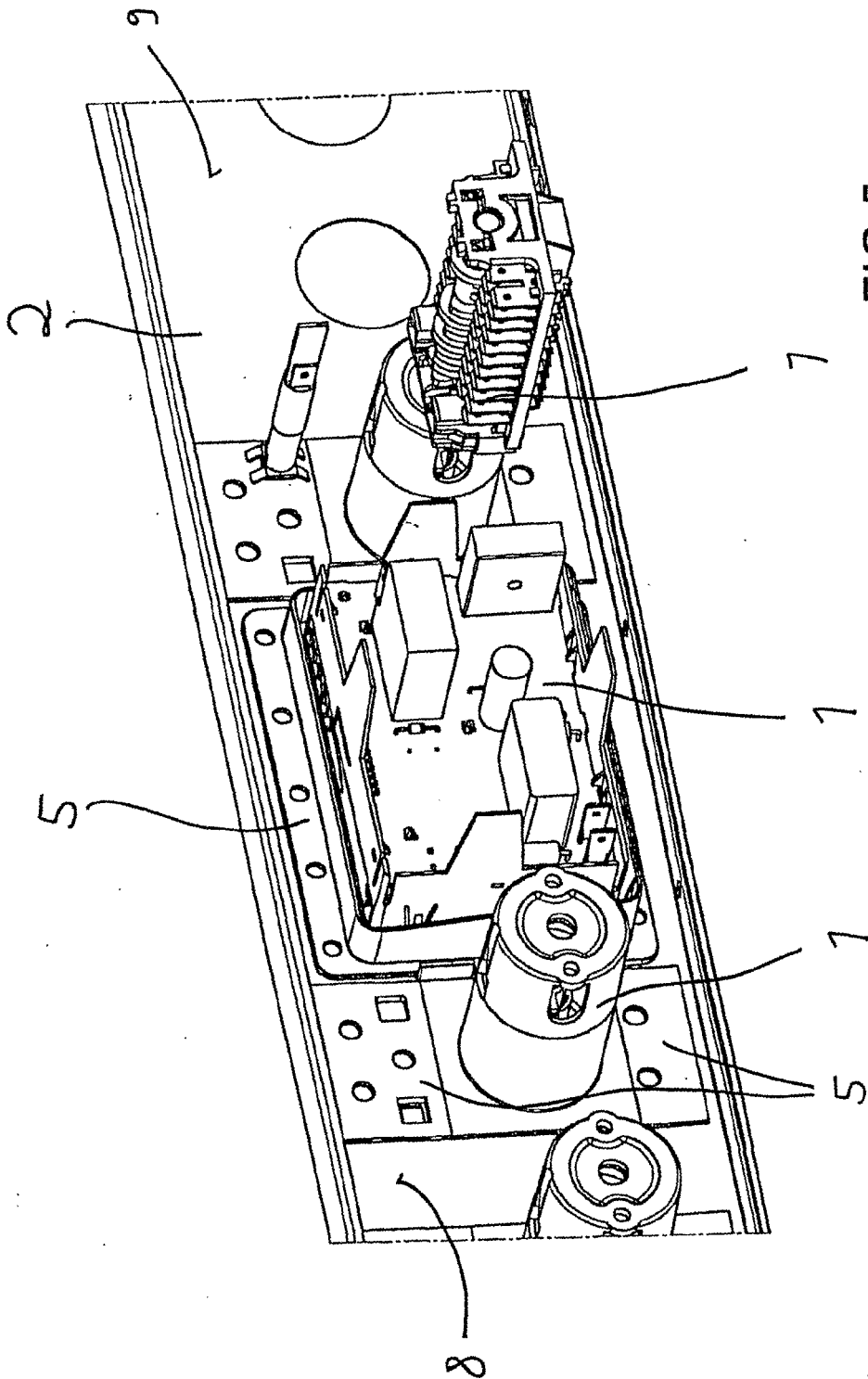

FIG 5



DOCUMENTS CONSIDERED TO BE RELEVANT			
Category	Citation of document with indication, where appropriate, of relevant passages	Relevant to claim	CLASSIFICATION OF THE APPLICATION (IPC)
X	DE 100 51 075 A1 (AEG HAUSGERAETE GMBH [DE]) 25 April 2002 (2002-04-25) * paragraph [0001] * * paragraph [0040] - paragraph [0041]; figures 4,5 *	1,14	INV. F24C7/08
A	-----	2,13,15	
X	GB 2 255 397 A (SAMSUNG ELECTRONICS CO LTD [KR]) 4 November 1992 (1992-11-04) * page 5, line 13 - page 6, line 11; figures 2,3 *	1,14	
A	-----	2-13,15	
X	US 2006/117813 A1 (HA YOUNG H [KR] ET AL) 8 June 2006 (2006-06-08) * paragraph [0061] - paragraph [0071]; figure 6 *	1,14	TECHNICAL FIELDS SEARCHED (IPC)  F24C A47L D06F
A	-----	2-13,15	
D,A	DE 101 57 221 A1 (BSH BOSCH SIEMENS HAUSGERAETE [DE]) 5 June 2003 (2003-06-05) * the whole document *	1-15	
	-----		
The present search report has been drawn up for all claims			
Place of search Munich		Date of completion of the search 5 July 2007	Examiner Hannam, Martin
CATEGORY OF CITED DOCUMENTS X : particularly relevant if taken alone Y : particularly relevant if combined with another document of the same category A : technological background O : non-written disclosure P : intermediate document		T : theory or principle underlying the invention E : earlier patent document, but published on, or after the filing date D : document cited in the application L : document cited for other reasons ----- & : member of the same patent family, corresponding document	

1

EPO FORM 1503 03.82 (P04C01)

**ANNEX TO THE EUROPEAN SEARCH REPORT  
ON EUROPEAN PATENT APPLICATION NO.**

EP 07 00 3636

This annex lists the patent family members relating to the patent documents cited in the above-mentioned European search report. The members are as contained in the European Patent Office EDP file on  
The European Patent Office is in no way liable for these particulars which are merely given for the purpose of information.

05-07-2007

Patent document cited in search report		Publication date	Patent family member(s)	Publication date
DE 10051075	A1	25-04-2002	NONE	
GB 2255397	A	04-11-1992	JP 5126344 A	21-05-1993
US 2006117813	A1	08-06-2006	NONE	
DE 10157221	A1	05-06-2003	NONE	

EPO FORM P0459

For more details about this annex : see Official Journal of the European Patent Office, No. 12/82

**REFERENCES CITED IN THE DESCRIPTION**

*This list of references cited by the applicant is for the reader's convenience only. It does not form part of the European patent document. Even though great care has been taken in compiling the references, errors or omissions cannot be excluded and the EPO disclaims all liability in this regard.*

**Patent documents cited in the description**

- DE 8535431 U1 [0004]
- DE 8623803 U1 [0005]
- DE 10309516 B3 [0006]
- DE 10349592 A1 [0006]
- DE 19917191 C2 [0006]
- DE 19504471 B4 [0006]
- EP 1639935 A2 [0007]
- EP 1045300 B1 [0007]
- DE 10337441 A1 [0008]
- DE 10157221 A1 [0008]
- DE 10307536 A1 [0008]
- DE 19645678 C2 [0008]