

(19) World Intellectual Property Organization
International Bureau



(43) International Publication Date
3 January 2008 (03.01.2008)

PCT

(10) International Publication Number
WO 2008/003076 A2

- (51) International Patent Classification: **Not classified**
- (21) International Application Number: PCT/US2007/072459
- (22) International Filing Date: 29 June 2007 (29.06.2007)
- (25) Filing Language: English
- (26) Publication Language: English
- (30) Priority Data: MI2006A001266 29 June 2006 (29.06.2006) IT
- (71) Applicant (for all designated States except US): **MEAD-WESTVACO CORPORATION** [US/US]; 11013 West Broad Street, Glen Allen, VA 23060 (US).
- (72) Inventor; and
- (75) Inventor/Applicant (for US only): **MARELLI, Andrea** [IT/IT]; Via G. Di Vittorio, 29 20090 Pieve, Emanuele, Via G. Di Vittorio, Frizzonasco, I-20090 Milan (IT).
- (74) Agent: **JENSEN, Devin R;** MeadWestvaco Corporation, 1021 Main Campus Drive, Floor 3, Centennial Campus, Raleigh, NC 27606, (US).
- (81) Designated States (unless otherwise indicated, for every kind of national protection available): AE, AG, AL, AM, AT, AU, AZ, BA, BB, BG, BH, BR, BW, BY, BZ, CA, CH, CN, CO, CR, CU, CZ, DE, DK, DM, DO, DZ, EC, EE, EG, ES, FI, GB, GD, GE, GH, GM, GT, HN, HR, HU, ID, IL, IN, IS, JP, KE, KG, KM, KN, KP, KR, KZ, LA, LC, LK, LR, LS, LT, LU, LY, MA, MD, ME, MG, MK, MN, MW, MX, MY, MZ, NA, NG, NI, NO, NZ, OM, PG, PH, PL, PT, RO, RS, RU, SC, SD, SE, SG, SK, SL, SM, SV, SY, TJ, TM, TN, TR, TT, TZ, UA, UG, US, UZ, VC, VN, ZA, ZM, ZW.
- (84) Designated States (unless otherwise indicated, for every kind of regional protection available): ARIPO (BW, GH, GM, KE, LS, MW, MZ, NA, SD, SL, SZ, TZ, UG, ZM, ZW), Eurasian (AM, AZ, BY, KG, KZ, MD, RU, TJ, TM), European (AT, BE, BG, CH, CY, CZ, DE, DK, EE, ES, FI, FR, GB, GR, HU, IE, IS, IT, LT, LU, LV, MC, MT, NL, PL,

[Continued on next page]

(54) Title: PUMPS AND METHODS FOR USING THE SAME

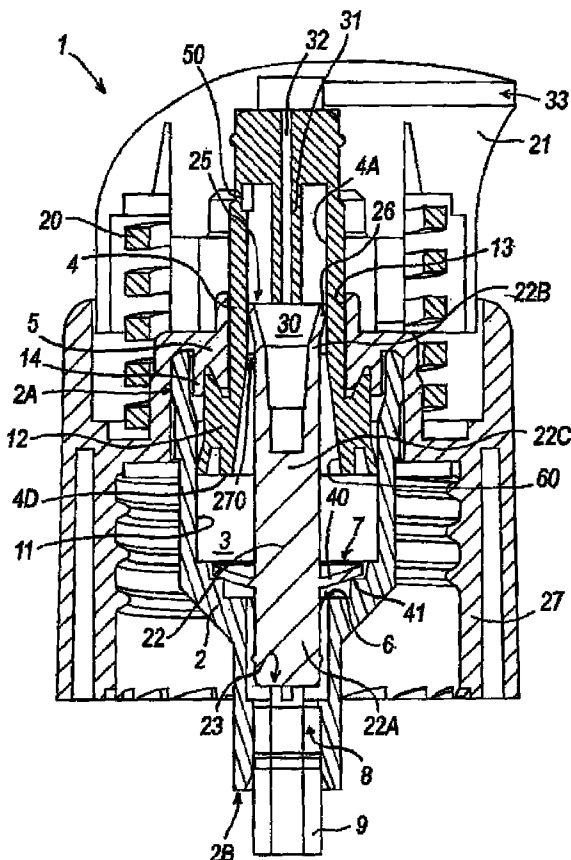

(57) Abstract: A simplified delivery pump for fluid substances may include a cup unit having an extended rod positioned inside the cup unit, a first end of the extended rod being inserted and held in a housing at the second end of the cup unit, and an intermediate portion of the rod having a cylindrical profile with a diameter which is less than the diameter of the cavity of this shaft within which the portion of the rod extends, and that this mobile stop valve for the cavity of the shaft includes a continuous flexible lip which protrudes out from a second end of the rod towards the outside of this cylindrical chamber, this lip sliding on contact and sealing the cylindrical surface of the cavity of the shaft itself.

WO 2008/003076 A2



PT, RO, SE, SI, SK, TR), OAPI (BF, BJ, CF, CG, CI, CM, GA, GN, GQ, GW, ML, MR, NE, SN, TD, TG).

For two-letter codes and other abbreviations, refer to the "Guidance Notes on Codes and Abbreviations" appearing at the beginning of each regular issue of the PCT Gazette.

Published:

— *without international search report and to be republished upon receipt of that report*

PUMPS AND METHODS FOR USING THE SAME

5 CROSS-REFERENCE TO RELATED APPLICATIONS

[0001] The present invention claims priority to Italian Patent Application MI2006A001266 filed on June 29, 2006, entitled "Pompa Semplificata di Mandata Di Sostanze Fluide Prelevate Da Un Contentitore," and incorporates the application herein by reference in its entirety.

10

BACKGROUND OF THE INVENTION

[0002] Field of the Invention: This invention relates to a delivery pump for fluid substances taken from a container. To be more specific, it refers to a delivery pump for fluid substances such as creams, gels or similar.

15

[0003] State of the Art: Delivery pumps for fluid substances are known, such as, for example, US Patent 6170713. The pump described in this US document includes a cup unit closed at its first end by a plate in which there is a space for the passage of a shaft on which a mobile piston close to the inner surface of the cup unit is engaged directly. To be more specific, the cup unit includes one-way valve units which can block a space for the fluid

20

at the bottom of the cup unit.

[0004] In addition, the inside of the cup unit has a first spring which can push the piston into a rest position. Internally, the shaft has a large axial cavity which houses a mobile valve element which contrasts with a second spring against a holding surface. This valve element opens to allow the supply of the fluid compressed by the piston inside the cup unit

25

only when the internal pressure of the fluid exceeds the pressure with which the spring keeps the valve elements pressed against a holding surface within the shaft itself.

[0005] This pump consists of many parts. Therefore, a large number of molds are required, leading to high initial costs. In addition, it is necessary to have a warehouse which can handle several parts.

30

[0006] In addition, the assembly of the pump is extremely difficult as it is very difficult to insert the valve elements within the shaft.

[0007] Thus, several assembly stages are required, which leads to long production times and very complex assembly machinery and equipment.

[0008] In addition, this pump, as it has such a high number of reciprocally mobile parts, may be quite unreliable.

5 [0009] Accordingly, it may be desirable to provide a simplified delivery pump for fluid substances taken from a container which consists of a limited number of parts. It may also be desirable to provide a delivery pump which requires a limited number of molds for its production and which can also be produced without the need to have a large number of parts in the warehouse. It may also be desirable to provide a simplified delivery pump which is
10 easy to assemble in few assembly stages and which does not require complex assembly equipment. It may also be desirable to provide a pump which is reliable to use.

BRIEF DESCRIPTION OF THE DRAWINGS

[0010] While the specification concludes with claims particularly pointing out and
15 distinctly claiming particular embodiments of the present invention, various embodiments of the invention can be more readily understood and appreciated by one of ordinary skill in the art from the following description of the invention when read in conjunction with the accompanying drawings in which:

[0011] FIG. 1 illustrates a side cross-section view of a pump according to
20 embodiments of the invention in a rest stage;

[0012] FIG. 2 illustrates a side cross-section view of a pump according to embodiments of the invention in a compression and supply stage;

[0013] FIG. 3 illustrates a side cross-section view of a pump according to
embodiments of the invention in an engagement stage;

25 [0014] FIG. 3A illustrates an enlarged portion of FIG. 3; and

[0015] FIG. 4 illustrates a side cross-section view of a pump according to
embodiments of the invention in a suction stage.

DETAILED DESCRIPTION OF THE INVENTION

30 [0016] According to embodiments of the invention, a simplified delivery pump for fluid substances may include a cup unit limiting a cylindrical chamber in which a hollow shaft extends, a plate mounted on a first open end of the cup unit, this cup unit having a space

at its second end which can be sealed closed by a one-way valve and a housing for the insertion of one end of a suction tube for taking the fluid substance from the container, a sliding piston sealing the surface of the cylindrical chamber, this piston being joined to this shaft and being positioned close to a first end of the shaft inside this chamber and protruding
5 out towards the inner surface of the cup unit, the plate having both a hole for the passage through it and for guiding this shaft and at least one holding element with this piston, a flexible body which acts to push this piston towards this plate, a mobile stop valve for the shaft cavity, characterized by the fact that an extended rod is positioned inside the cup unit, a first end of the extended rod being inserted and held in a housing at the second end of the cup
10 unit, and that an intermediate portion of the rod has a cylindrical profile with a diameter which is less than the diameter of the cavity of this shaft within which this portion of the rod extends, and that this mobile stop valve for the cavity of the shaft includes a continuous flexible lip which protrudes out from a second end of the rod towards the outside of this cylindrical chamber, this lip sliding on contact and sealing the cylindrical surface of the
15 cavity of the shaft itself.

[0017] Advantageously, the lip defines an indentation at the second end of the rod and a shaped element protrudes from the top of the shaft which can be inserted in the indentation defined by the lip when the shaft is totally lowered within the pump, the shaped element being substantially complementary to the indentation.

20 [0018] In addition, the one-way valve consists of a flexible discoidal unit which protrudes out from the surface of the rod close to the first end and a holding surface at the second internal end of the cup unit, the discoidal unit preventing the passage of the fluid under rest or supply conditions, and the holding surface is sharp.

25 [0019] The one-way valve can also be a ball valve positioned between the cup unit and the bottom of this rod.

[0020] Advantageously, a drive and supply button is anchored on the outside to the second end of the shaft, the flexible element being positioned between the button and the plate and being created using a spring.

30 [0021] In addition, the shaft has, at its second end, a protrusion inside the cavity of the shaft itself, the protrusion being located in a position which can interfere with the protruding lip in order to open the valve when the piston is pressed in one of its limit positions.

[0022] The protrusion may also be replaced by a groove in the inner surface of the cavity of the shaft itself, the groove being located in a position to cooperate with the protruding lip in order to open the valve when the piston is pressed in one of its limit positions.

5 [0023] Alternatively, instead of the protrusion and the groove, the cup unit may have, at its second end, inside the chamber, a protrusion which can interfere with the sliding piston in order to compromise its seal when it is pressed in one of its limit positions.

[0024] Advantageously, the plate is made together with a ring nut to permit the mounting of the pump on the container, and the plate holding element is ring-shaped and acts
10 as a holding stop for the piston when it is in a rest position.

[0025] In addition, the cavity of the shaft has, near its first end, a conical guide.

[0026] As illustrated, the pump may include a cup unit 2 limiting a cylindrical chamber 3 in which a hollow shaft 4 extends. The surface 4A of the shaft which defines the cavity has a conical guide portion 60 near a first end of the shaft. There is also a plate 5
15 mounted on a first open end 2A of the cup unit 2. The plate is made together with a ring nut 27 for securing to a container on which the pump will be mounted. The cup unit 2 has, at its second end 2B, a space 6, which can be sealed closed by a one-way valve 7. The cup unit also has, at its second end 2B, a housing 8 for the insertion of one end of a suction tube 9 for taking the fluid substance from the container.

20 [0027] To be more specific, the space 6, when the one-way valve 7 is open, connects the inside of the cylindrical chamber 3 to the tube 9.

[0028] The pump also includes a sliding piston 12 sealing the inner surface 11 of the cylindrical chamber 3. This piston 12 is made together with the shaft 4 and, therefore, is joined to it.

25 [0029] The piston is also positioned near a first end 4D of the shaft 4 inside the chamber 3 and protruding out towards the inner surface of the cup unit 3.

[0030] The plate 5 has a hole 13 for the passage through it and for guiding this shaft 4 and also has a holding element with this piston. This holding element 14 is ring-shaped and has a ring-shaped relief 15 with a tapered cross-section in which a corresponding upper (in
30 figure 2) ring-shaped portion 16 of the piston 12 is wedged.

[0031] When the piston 12 is in its rest position, the ring-shaped portion 16 is wedged in the ring-shaped relief 15 and the inside of the container, to which the pump is

secured, is isolated from the outside. When, on the other hand, the piston 12 is far from the rest position, the ring-shaped portion 16 is detached from the relief 15 and an air space is created between the outside and inside of the container. To be more specific, the air is suctioned inside the container when it is depressed due to the corresponding exit of part of its content after a certain quantity of product is supplied by the pump. To be more precise, the route which the air takes to enter the container is easily seen in figure 2; the air basically passes between the shaft 4 and the shaft guide element in the plate 5 to arrive at an intermediate chamber 160 which is created between the piston and the plate itself.

Subsequently, this air is suctioned through a special space created between the plate 5 and the outside of the cup unit 2 at the zone 19 in which the cup unit 2 is click-mounted to the plate.

[0032] The piston 12 is pushed towards the plate in its rest position by a flexible body. In the creation form illustrated, the flexible body is a spring 20 and a drive and supply button 21 is anchored on the outside to the second end of the shaft. The spring 20 is positioned between the button and the plate 5 in order not to be in contact with the fluid supplied by the pump.

[0033] In an alternative creation form, however, this spring may also be placed between a groove in the cup unit and the piston itself.

[0034] An extended rod 22 is positioned inside the cup unit 2 and a first end 22A of the extended rod is inserted and held by a click-in undercut in a housing 23 at the second end 2B of the cup unit 2. The housing 23 has a number of tabs (not shown) which secure this rod 22. The rod has an intermediate portion 22C with a cylindrical profile with a diameter which is less than the diameter of the cavity of the shaft within which this portion of the rod extends. The cavity of the shaft 4 connects to the outside and the cavity itself is used to supply the fluid substance. The cavity has a mobile stop valve 25 for the cavity itself and this valve 25 includes a continuous flexible lip 26 which protrudes out from a second end 22B of the rod towards the outside of this cylindrical chamber. To be more specific, this lip 26 has a truncated conical shape and its shape creates, between the lip and the inner surface of the shaft, a wedge-shaped gap 270 which is tapered as the cylindrical chamber 3 moves away, in the direction of the supply of the fluid. The lip 26 is substantially sliding (with the movement of the piston 12) in contact with and sealing the cylindrical surface 4A of the cavity of the shaft 4 itself.

[0035] The lip 26 defines, at the second end of the rod, an indentation 30 which, because of its shape, helps to provide the lip 26 with the required flexibility it must have.

[0036] In addition, a shaped element 31 protrudes from the top of the shaft which can be inserted in the indentation 30 when the shaft is totally lowered within the pump; the
5 shaped element is substantially complementary to the indentation and when it is inserted in the indentation it minimizes the space between the top of the rod and the shaft.

[0037] In the shaped element 31, and aligned to it, there is also a through hole 32 connecting to a supply hole 33 leading to the outside of the button 21.

[0038] When the chamber 3 is pressurized by the lowering of the shaft, and the
10 pressure inside it exceeds a preset threshold related to the flexibility of the lip 26, the lip itself bends and allows the supply of the fluid in the direction of the arrows E in figure 2.

[0039] The one-way valve 7 consists of a flexible discoidal unit 40 which protrudes out from the surface of the rod 22 close to its first end 22A and a sharp holding surface 41 at the second internal end 2B of the cup unit 2. To be more specific, the discoidal unit 40
15 prevents the passage of the fluid from the chamber 3 towards the tube 9 under rest or supply conditions.

[0040] The one-way valve described above, made together with the rod 22, may be replaced by a conventional one-way ball valve commonly used in these types of pumps. In this case, the cup unit 2 has a housing for the ball and a holding surface with it, and there are
20 tabs above the ball which trap the rod. This ball is mobile within the housing.

[0041] The shaft 4 has, at its second end, a groove 50 on the inner surface 40 of the cavity of the shaft 4 itself. This groove is located in a position to cooperate with the protruding lip 26 in order to open the valve 25 (Figure 3A) when the piston 12 is pressed in one of its limit positions, to apply the exit (arrows 5) of the compressed air into the
25 cylindrical chamber 3 during a pump engagement stage.

[0042] This groove may be replaced by other engagement means such as, for example, a protrusion inside the cavity of the shaft itself. This protrusion must be located in a position to interfere with the protruding lip in order to open the valve when the piston is pressed in one of its limit positions. In addition, the cup unit 2 may have, at its second end,
30 inside the chamber, at least one protrusion to interfere with the sliding piston in order to open its seal, when the piston is pressed in one of its limit positions.

[0043] Advantageously, this kind of pump structure makes it possible to obtain a very compact pump which, to be more specific, has a very limited internal height and a very limited external height.

[0044] Having thus described certain particular embodiments of the invention, it is understood that the invention defined by the appended claims is not to be limited by 5 particular details set forth in the above description, as many apparent variations thereof are contemplated. Rather, the invention is limited only by the appended claims, which include within their scope all equivalent devices or methods which operate according to the principles of the invention as described.

CLAIMS

What is claimed is:

1. A simplified delivery pump for fluid substances taken from a container of these substances, including a cup unit limiting a cylindrical chamber in which a hollow shaft
5 extends, a plate mounted on a first open end of the cup unit, this cup unit having a space at its second end which can be sealed closed by a one-way valve and a housing for the insertion of one end of a suction tube for taking the fluid substance from the container, a sliding piston sealing the surface of the cylindrical chamber, this piston being joined to this shaft and being
10 positioned close to a first end of the shaft inside this chamber and protruding out towards the inner surface of the cup unit, the plate having both a hole for the passage through it and for guiding this shaft and at least one holding element with this piston, a flexible body which acts to push this piston towards this plate, a mobile stop valve for the shaft cavity, characterized by the fact that an extended rod is positioned inside the cup unit, a first end of the extended
15 rod being inserted and held in a housing at the second end of the cup unit, and that an intermediate portion of the rod has a cylindrical profile with a diameter which is less than the diameter of the cavity of this shaft within which this portion of the rod extends, and that this mobile stop valve for the cavity of the shaft includes a continuous flexible lip which protrudes out from a second end of the rod towards the outside of this cylindrical chamber, this lip sliding on contact and sealing the cylindrical surface of the cavity of the shaft itself.
20
2. A pump in accordance with Claim 1, characterized by the fact that this lip defines an indentation at the second end of this rod.
3. A pump in accordance with Claim 2, characterized by the fact that a shaped
25 element protrudes from the top of the shaft which can be inserted in this indentation defined by the lip when the shaft is totally lowered within the pump, this shaped element being substantially complementary to this indentation.
4. A pump in accordance with Claim 1, characterized by the fact that this one-
way valve consists of a flexible discoidal unit which protrudes out from the surface of this rod close to the first end and a holding surface at the second internal end of the cup unit, this discoidal unit preventing the passage of the fluid under rest or supply conditions.
- 30 5. A pump in accordance with Claim 4, characterized by the fact that this holding surface is sharp.

6. A pump in accordance with Claim 1, characterized by the fact that this one-way valve is a ball valve positioned between this cup unit and the bottom of this rod.

7. A pump in accordance with Claim 1, characterized by the fact that a drive and supply button is anchored on the outside of the second end of this shaft, this flexible element
5 being positioned between this button and this plate.

8. A pump in accordance with Claim 1, characterized by the fact that this flexible element is a spring.

9. A pump in accordance with Claim 1, characterized by the fact that this shaft has, at its second end, at least one protrusion inside the cavity of the shaft itself, this
10 protrusion being located in a position which can interfere with this protruding lip in order to open this valve when the piston is pressed in one of its limit positions.

10. A pump in accordance with Claim 1, characterized by the fact that this shaft has, at its second end, at least one groove in the inner surface of the cavity of the shaft itself, this groove being located in a position to cooperate with this protruding lip in order to open
15 this valve when the piston is pressed in one of its limit positions.

11. A pump in accordance with Claim 1, characterized by the fact that this cup unit has, at its second end, inside the chamber, at least one protrusion which can interfere with this sliding piston in order to compromise its seal when it is pressed in one of its limit
positions.

20 12. A pump in accordance with Claim 1, characterized by the fact that this plate is made together with a ring nut to permit the mounting of this pump on this container.

13. A pump in accordance with Claim 1, characterized by the fact that this plate holding element is ring-shaped and acts as a holding stop for this piston when it is in a rest
position.

25 14. A pump in accordance with Claim 1, characterized by the fact that this shaft cavity has, near its first end, a conical guide.

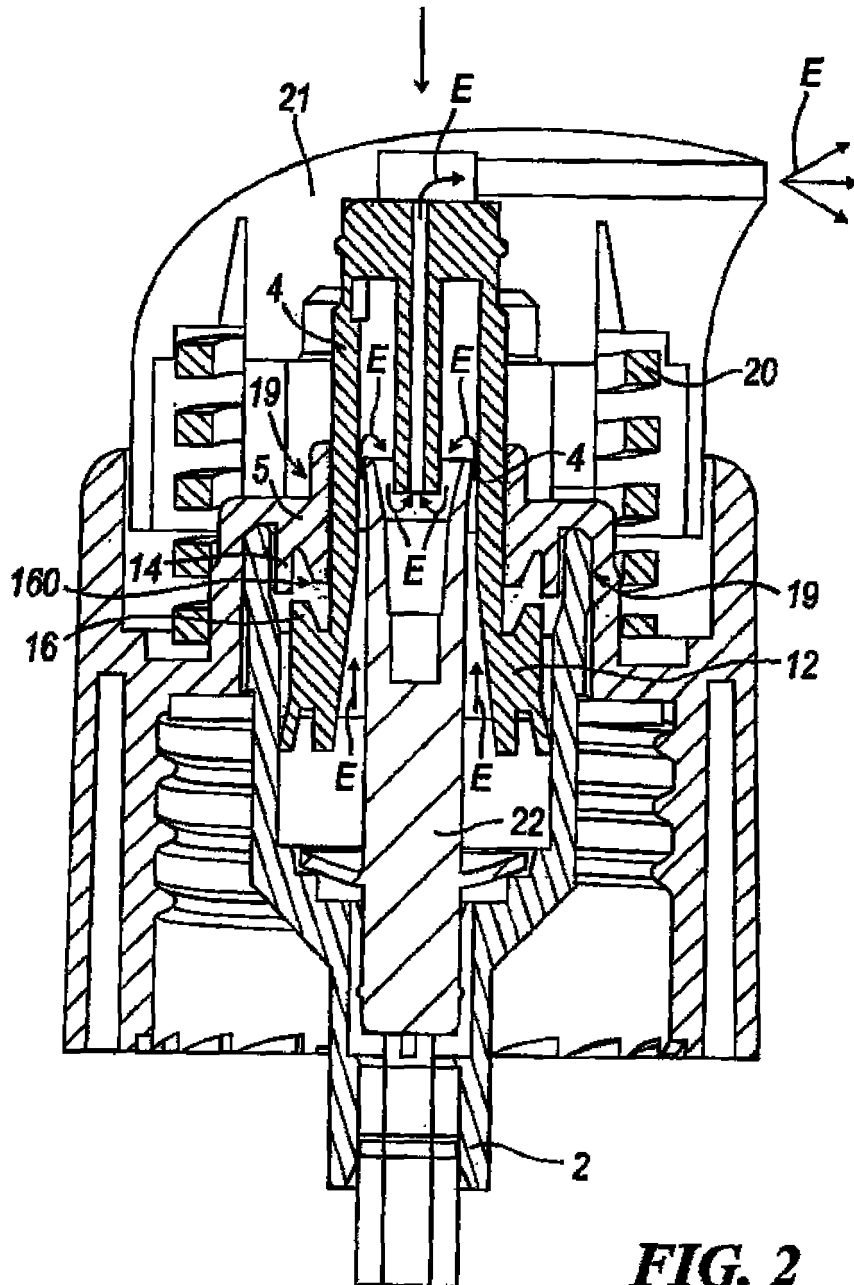

FIG. 2

3 / 4

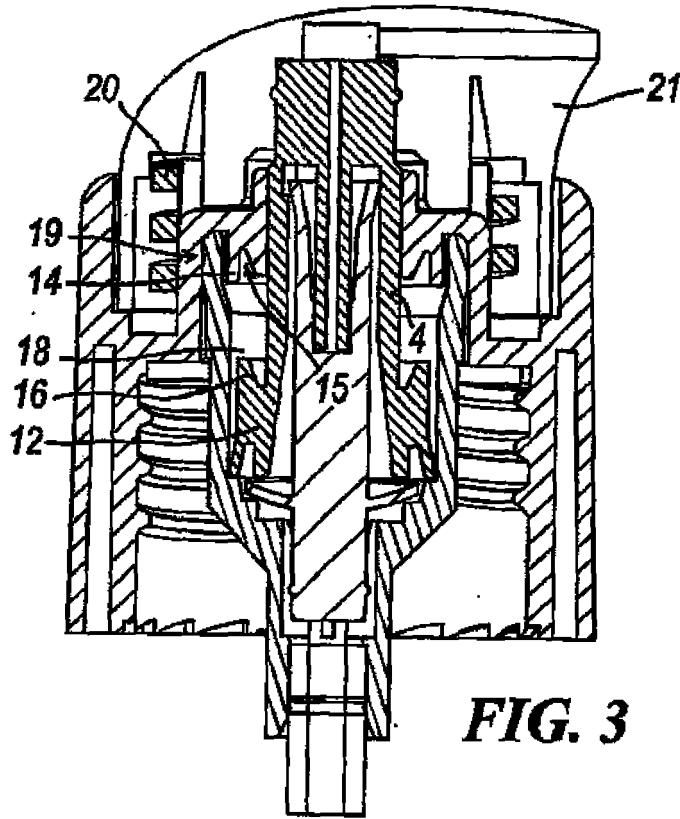

FIG. 3

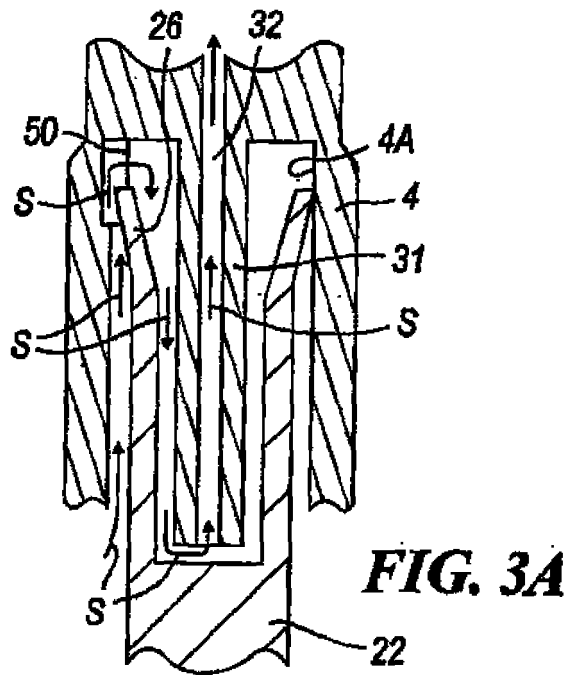

FIG. 3A

4 / 4

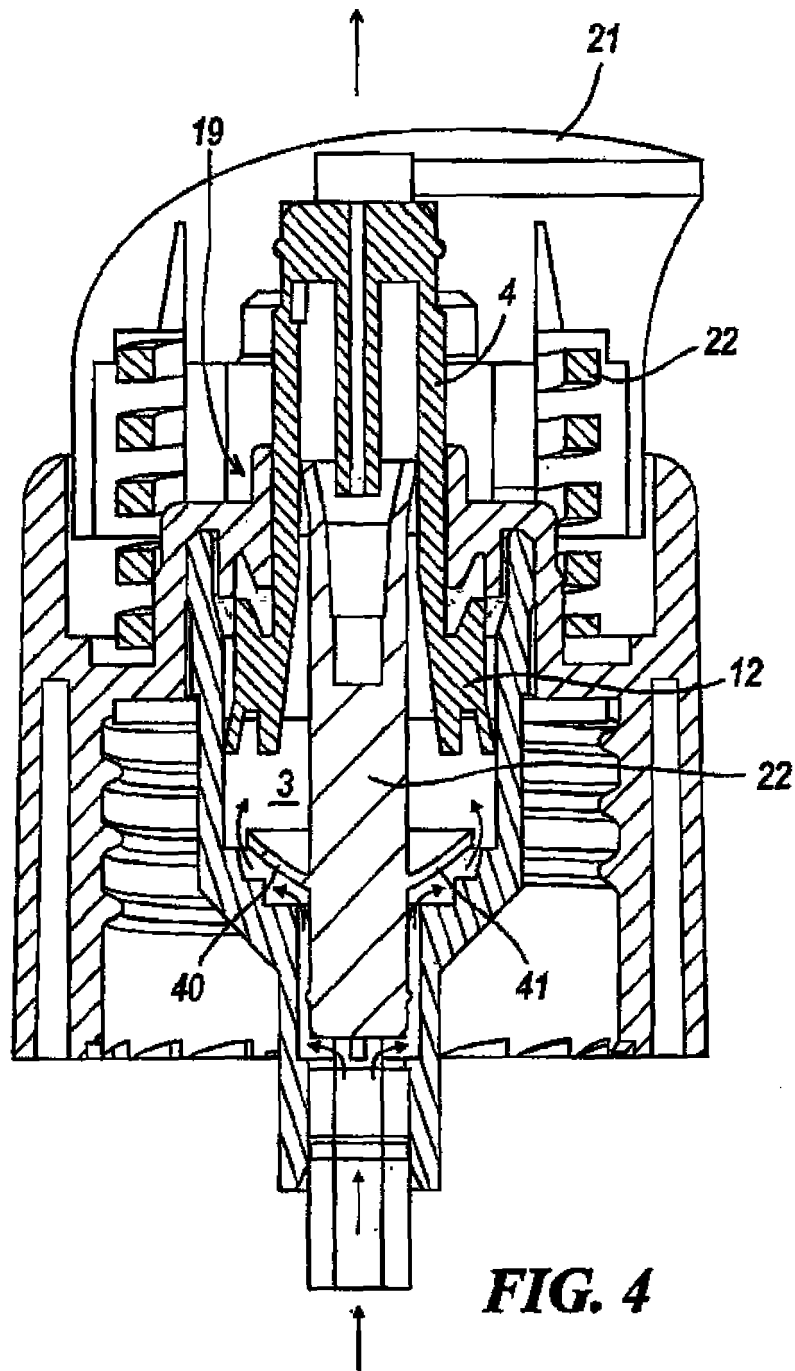

FIG. 4