

H. HOLTE.
LUBRICATING DEVICE FOR MILK CENTRIFUGES AND THE LIKE.
APPLICATION FILED SEPT. 10, 1920.

1,416,640.

Patented May 16, 1922.

Fig. 1.

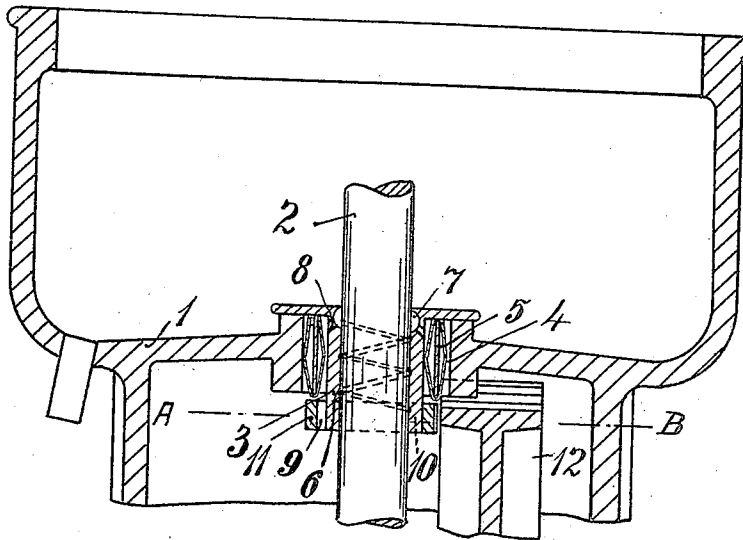
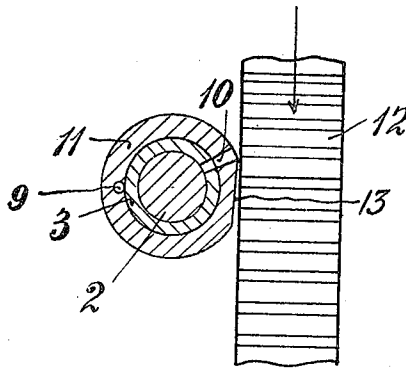

Fig. 2.



Inventor,
Halvor Holte,
By *Henry Orth* atty.

UNITED STATES PATENT OFFICE.

HALVOR HOLTE, OF SKIEN, NORWAY, ASSIGNOR OF ONE-HALF TO A/S SEPARATOR,
OF SKIEN, NORWAY.

LUBRICATING DEVICE FOR MILK CENTRIFUGES AND THE LIKE.

1,416,640.

Specification of Letters Patent. Patented May 16, 1922.

Application filed September 10, 1920. Serial No. 409,333.

To all whom it may concern:

Be it known that I, HALVOR HOLTE, a subject of the King of Norway, residing at Skien, Norway, have invented certain new and useful Improvements in Lubricating Devices for Milk Centrifuges and the like; and I do hereby declare the following to be a full, clear, and exact description of the invention, such as will enable others skilled in the art to which it appertains to make and use the same, reference being had to the accompanying drawings, and to letters or figures of reference marked thereon, which form a part of this specification.

In milk centrifuges and similar apparatus it is known to arrange the lubrication of the bolster in such way that the lubricant (oil) is lifted from a well in the housing by aid of a slowly moving member and then scraped off by brushes or the like and conducted to the bolster by aid of a shute or the like, whereupon it is screwed up along the spindle by aid of helical grooves.

The object of my invention is to simplify this arrangement in such way that it is possible to dispense with the intermediate parts between the slowly moving member or wheel and the bolster. This I obtain by providing in the bolster sleeve a channel, the opening of which has such a position in relation to the side face of the oil carrying wheel, that when the bolster has been placed in position, this opening will be so near to and at such an angle to the said side face as to allow of a direct overflow of the oil from the said side face into this channel opening or mouth. This transmission of oil will take place even if the channel mouth is not in direct contact with the rotating wheel, it being sufficient to have the gap between the two parts so small that a transmission by adhesion will take place by the slight vibrations caused in the bolster sleeve by the rotating motion of the spindle.

The accompanying drawings illustrate by way of example an executorial form of the invention, Fig. 1 being a vertical section through the bolster portion of a milk centrifuge and Fig. 2 being a horizontal section on line A—B in Fig. 1. 1 is the housing of the centrifuge in which the vertical centrifuge spindle 2 is placed in a bolster bearing in well known manner. 3 is the bolster sleeve which is arranged resilient in known way by aid of springs 4 arranged around it, said

springs being fastened onto an outer cylindrical sleeve 5. The bolster sleeve is in known manner provided with a helical groove 6, by aid of which the oil, fed in at the lower end of the bolster sleeve, is lifted along the spindle 2 to a ring shaped chamber 7 in the upper part of the bolster sleeve, thereby lubricating the spindle. From this ring shaped chamber 7 the oil is through borings 8 carried back to the lower part of the bolster sleeve from which it is directed to the other rotating parts of the mechanism through one or more channels 9.

Now according to my invention I arrange in a flange 11, or a similar part integral with the bolster sleeve or fastened to it, an oil collecting channel 10. In the executorial form illustrated in the drawings the mouth of the channel 10 is placed at a suitable angle to the side face of the slowly moving oil lifting wheel 12 (which may either be any of the slow moving transmission wheels of the mechanism or a wheel especially arranged for this purpose), by providing a flattened part 13 on the part of the flange 11 adjacent to said channel mouth. As will be seen in Fig. 1 this flattened part is not quite in contact with the side face of the wheel 12, there being a small gap between the two parts, serving to compensate the small vibration of the bolster sleeve during the rotation of the centrifuge spindle 2. When the bolster sleeve is mounted the flange 11 is by hand placed against the side face of the wheel 12, but as soon as it is let loose there will be provided a small gap between the two faces by the spring action of the bolster springs 4 and the flange 11 will then be in the position illustrated in Fig. 2. By aid of this arrangement the oil is transmitted direct from the rotating oil lifting member to the mouth of the oil collecting channel 11, from which it is carried direct on to the groove 6 providing for the lubrication of the spindle 2.

For bolsters without spring action the arrangement is exactly the same as that already specified and shown.

Claims:

1. In lubricating device for the spindles of milk centrifuges and the like of the kind in which the oil to be transmitted to the bolster is lifted from an oil well by a slowly moving member the combination of a substantially vertical bolster sleeve and a lubricating groove in said sleeve adjacent to the

spindle, with an oil collecting channel in the lower part in said bolster sleeve, the mouth of which channel is situated so near to and at such an angle to the face of said slowly moving oil lifting member as to collect oil from the same and transmit it to said spindle lubricating groove.

2. In lubricating device for the spindles of milk centrifuges and the like of the kind in which the oil to be transmitted to the bolster is lifted from an oil well by a slowly moving member the combination of a substantially vertical bolster sleeve and a lubricating groove in said sleeve adjacent to the spindle, with an oil collecting channel arranged in a flange in the lower part in said bolster sleeve, the mouth of which channel is situated so near to and at such an angle to the face of said slowly moving oil lifting member as to collect oil from the same and transmit it to said spindle lubricating groove.

3. In lubricating device for the spindles of milk centrifuges and the like of the kind in which the oil to be transmitted to the bolster is lifted from an oil well by a slowly moving member the combination of a bolster sleeve and a lubricating groove in said sleeve adjacent to the spindle, with an oil collecting channel arranged in a flange in the lower part in said bolster sleeve, the mouth of which channel is situated so near to and at such an angle to the face of said slowly moving oil lifting member as to collect oil from the same and transmit it to said spindle lubricating groove, and a flattened part on said flange, adjacent to the mouth of said oil collecting channel.

4. In lubricating device for the spindles of milk centrifuges and the like of the kind in which the oil to be transmitted to the bolster is lifted from an oil well by a slowly moving member the combination of a bolster sleeve and a lubricating groove in said sleeve adjacent to the spindle, with an oil collecting channel arranged in a flange in the lower part in said bolster sleeve, the mouth of which channel is situated so near to and at such an angle to the face of said slowly moving oil lifting member as to collect oil from the same and transmit it to said spindle lubricating groove, but leaving a small gap between said flange and said slowly moving oil lifting member.

5. In a lubricating device for the spindles of milk centrifuges and the like, in which the oil to be transmitted to the bolster is lifted from an oil well by a slowly moving member; the combination of a bolster sleeve having a spiral lubricating groove and an oil collecting channel in the lower part of said bolster extending to the lower end of said spiral groove, said bolster having an oil collecting chamber at its top directing overflow oil to the outside of the bolster and said collecting channel arranged at an angle to the slowly moving surface carrying oil adhering thereto to said channel.

In testimony that I claim the foregoing as my invention, I have signed my name in presence of two subscribing witnesses.

HALVOR HOLTE.

Witnesses:

MAGNUS BRIGGS,
A. B. COOK.